



## 1. Product Overview

Thank you for purchasing the Premier LC laser. This emits a Visible / IR spot/projection. If you have any problems or require help when using the Premier LC please call us on +44 (0)1495 212213 or contact your local representative.

The Premier laser diode modules represent the highest level of optical and electrical performance at an economical price, a combination that is unmatched in the marketplace.

The secret of their superiority is a control circuit design that not only gives you excellent output power stability over time and temperature, but also offers fast, closed-loop modulation with an extinction ratio as high as 10,000:1. The LC version allows you to control the output intensity linearly by applying a voltage of between 0 to 1 volts, to the control input. The output intensity will faithfully replicate any arbitrary signal you wish to apply within the limits of the laser module's maximum rise and fall time. A wide range of wavelengths, powers and lens options are available, each combination having been carefully selected to provide you optimum performance, while ensuring the laser diode is never over driven.



# 2. Product Operation

## A: CW Mode

To operate the laser in CW mode connect 4 way JST (see diagram A) to back of laser module.

Premier LC		
Pin 1	Red Lead	+5 Vdc $\pm$ 250mV
Pin 2	Black Lead	0 Vdc
Pin 3	Yellow Lead	Not Connected
Pin 4	Green/Yellow Lead	Earth

## B: Linear Modulation Function

To linearly modulate the laser any modulation signal up to 300kHz (dependant on diode) with an amplitude of 0V to +1Vdc can be applied to yellow lead.

Premier LC		
Pin 1	Red Lead	+5 Vdc $\pm$ 250mV
Pin 2	Black Lead	0 Vdc
Pin 3	Yellow Lead	Input Modulation Signal 0 to +1 Vdc
Pin 4	Green/Yellow Lead	Earth

## C. Setting the power via a resistor

Alternatively the yellow lead can be used for a linear power control function. In this situation, the laser power is denoted by a voltage applied to the yellow lead, 0V turning the laser off and +1Vdc giving maximum power, with linear trend between. (See linear intensity graph below)

Premier LC		
Pin 1	Red Lead	+5 Vdc $\pm$ 250mV
Pin 2	Black Lead	0 Vdc
Pin 3	Yellow Lead	Input Control Voltage 0 to +1 Vdc
Pin 4	Green/Yellow Lead	Earth

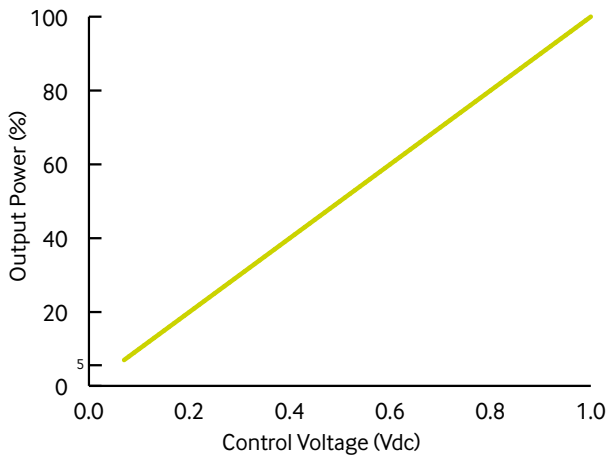

#### D) Setting the Output Power Via a Resistor

The control wire has a 10k Ohm input impedance connected to an internal 1V source which is used as the reference for the factory set power. Measuring the voltage between the Yellow and Black wires with a high (>10M Ohm) impedance voltmeter, will give a reading of 1 V ± 2%. Connecting a 10k Ohm resistance between the Yellow and Black wires will result in the reading falling to 0.5V and the light output falling to half the factory set power. Other outputs between 0

and the factory set power can be achieved with a single resistor  $R_x$  by using the formula:

Where  $P_o$  is the required power output  
as  $P_{fs}$  is the factory set power

$$R_x = \frac{P_o * 10K}{P_{fs} - P_o}$$

#### Green/Yellow Lead (Case earth)

The Green/Yellow is internally connected to 0 volts via a 1MΩ resistor to provide a resistive dissipation path for EMC & Static protection. If your power supply has a mains ground connection connect the Green/Yellow wire to it, otherwise connect it to 0V along with the Black wire.

## 3. Focus Adjustment

The focus of the of the Premier LC can be adjusted in one of two method depending on the model.

#### 3A. Premier LC fitted with projection optics

1. Remove the projection optic from the collimating lens assembly with the supplied key (see drawing F).
2. Slacken lock ring fitted to the collimating lens assembly (see drawing B).
3. Adjust focus by turning collimating lens assembly till the desired focus is achieved.
4. Tighten locking ring.
5. Refit projection optic and rotate until the best pattern is achieved.

#### 3B. Premier LC fitted with dot optics

1. Insert focus key into laser barrel and align with focus control groves.
2. Turn the focus key until desired focus is achieved

# 4. Mounting

To ensure the lifetime and the stability of the laser it is recommended that it is mounted in a suitable Heat sink/mount. The case temperature should be kept within the specified range at all times, failure to do this could result in shortened lifetime or catastrophic failure. As a guide, laser diode lifetime decreases by a factor of two (approx.) for every ten degree increase in operating temperature.

There are two mounting clamps available as standard from Global laser for the Premier LC range.

Global Laser's Heavy Duty Clamp has parallel and vertical adjustment which allows the user to aim the laser in any required direction or angle, the robust aluminium construction also assists in conducting heat away from the laser body as well as prevents movement due to shock and vibration. The base plate of the Heavy Duty Clamp has a series of threaded holes to allow secure fastening to stable surface. A Magnetic Base is also available which simply screws in to the base of the Heavy Duty Clamp and allow it to be fitted to a ferrous surface.

The Swivel Mount is available for 15 mm diameter lasers. It provides the user with up and down tilt movement as well as +/- 45° swivel. The base plate has a series of holes which allows the clamp to be fixed directly onto a machine or workbench. On the rear of the main block are two M3 threaded holes which enable heatsink fins to be attached if required.

## **4A Mounting the Premier LC in the Heavy Duty Clamp**

1. Un-tighten Allen screw A (see drawing C) with the supplied Allen key
2. Slide the laser into the mounting hole (see drawing C) and tighten Allen key A.
3. For vertical adjustment of the laser un-tighten Grub screw A (see drawing C). This will allow the section mounting the laser to be adjusted. When the vertical posting is complete re-tighten grub screw A.
4. For horizontal adjustment of the laser un-tighten Grub screw B (see drawing C). This will allow the main body of the mount to be moved. When the horizontal positing is complete re-tighten grub screw B.
5. To secure the Heavy Duty Clamp to a surface machine screw or studs can be used in conjunction with the base section (see drawing D for thread details)

## **4B Mounting the Premier LC in the Heavy Duty Clamp with the Magnetic Base**

1. Un-tighten Allen screw A (see drawing C) with the supplied Allen key.
2. Slide the laser into the mounting hole (see drawing C) and tighten Allen key A.
3. For vertical adjustment of the laser un-tighten Grub screw A (see drawing C). This will allow the section mounting the laser to be adjusted. When the vertical posting is complete re-tighten grub screw A.

4. For horizontal adjustment of the laser un-tighten Grub screw B (See drawing C). This will allow the main body of the mount to be moved. When the horizontal positing is complete re-tighten grub screw B.

#### 4C Mounting the Premier LC in the Swivel Mount

1. Un-tighten Allen screw A (see drawing E)
2. Slide the laser into the mounting hole (see drawing E) and tighten Allen key A.
3. For vertical adjustment of the laser un-tighten Allen screw B (see drawing E). This will allow the section mounting the laser to be adjusted. When the vertical posting is complete re-tighten Allen screw B.
4. For horizontal adjustment of the laser un-tighten Allen screw C (see drawing E). This will allow the main body of the mount to be moved. When the horizontal positing is complete re-tighten Allen screw C.
5. To secure the swivel mount to a surface screws, machine screw can be used in conjunction with the base section (see drawing E for thread details)

## 5. Cleaning The Optics

It is recommended that when the Premier LC laser is not in use the supplied protective cap is placed over the optics to reduce the risk of the being contaminated by dirt. If the laser pattern becomes fuzzy or unclear, please check the following:

1. Check the laser is in focus
2. Verify the optical lens is clean, if the area has been contaminated please remove

## 6. Safety & Classification

These modules are intended for incorporation into customer equipment. They are classified in accordance with IEC60825-1 2007, which should be consulted prior to designing or using any laser product. The following labels are supplied for attachment to the customer's equipment, but responsibility for compliance with the standard remains with the user.

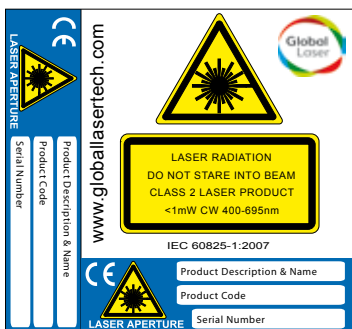

Class 2 Laser Label

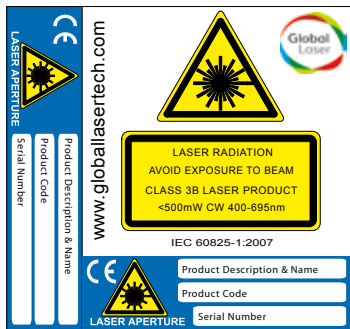

Class 3B Laser Label

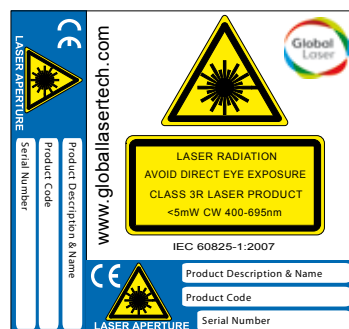

Class 3R Laser Label

# 7. Diagrams

## A) Premier LC

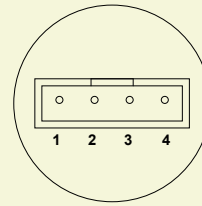
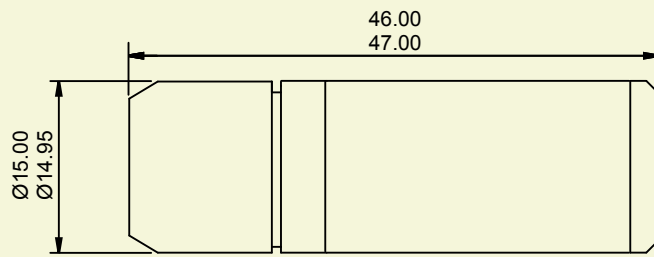

Pin 1 - Red  
Pin 2 - Black  
Pin 3 - Yellow  
Pin 4 - Green/Yellow

## B) Premier LC with External Optic

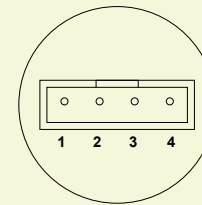
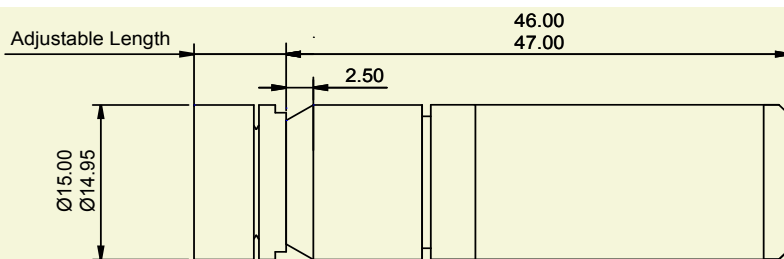

Pin 1 - Red  
Pin 2 - Black  
Pin 3 - Yellow  
Pin 4 - Green/Yellow

## C) Heavy Duty Mounting Clamp

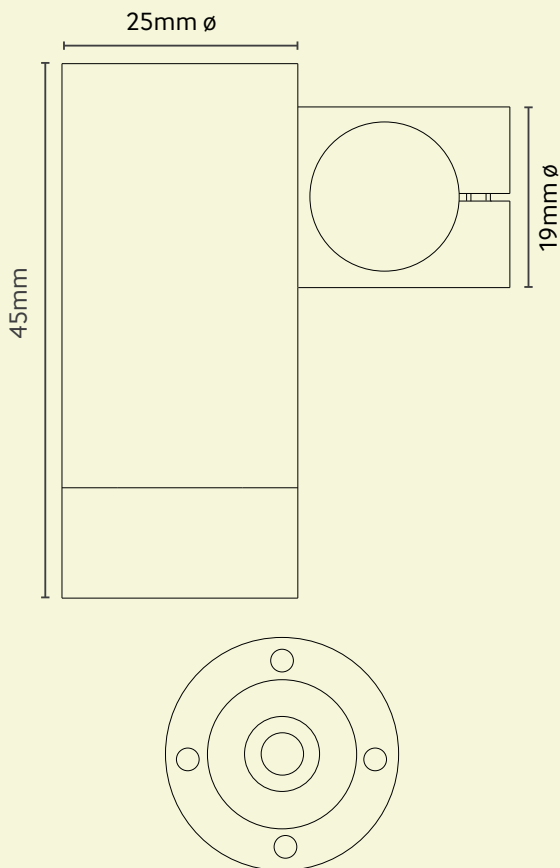

M5 Mounting hole on base

## D) Magnetic Base

*Drawings not to scale*

FRONT VIEW

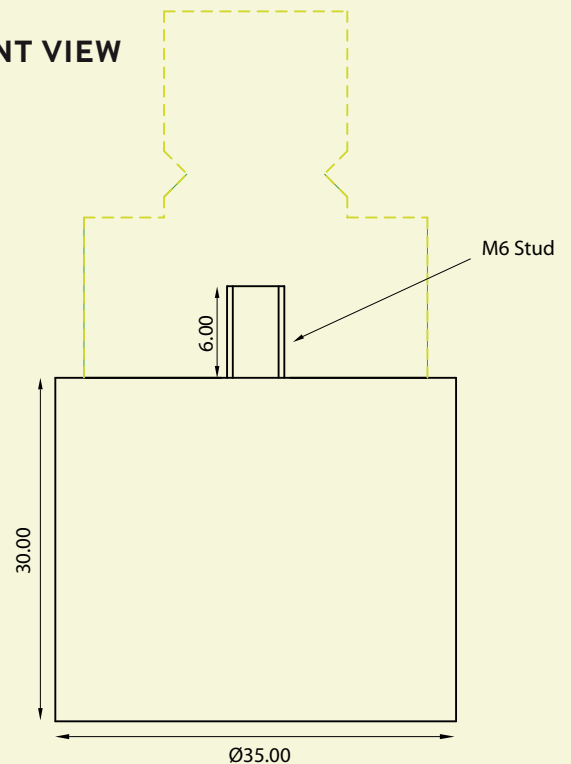

## E) Swivel Mount

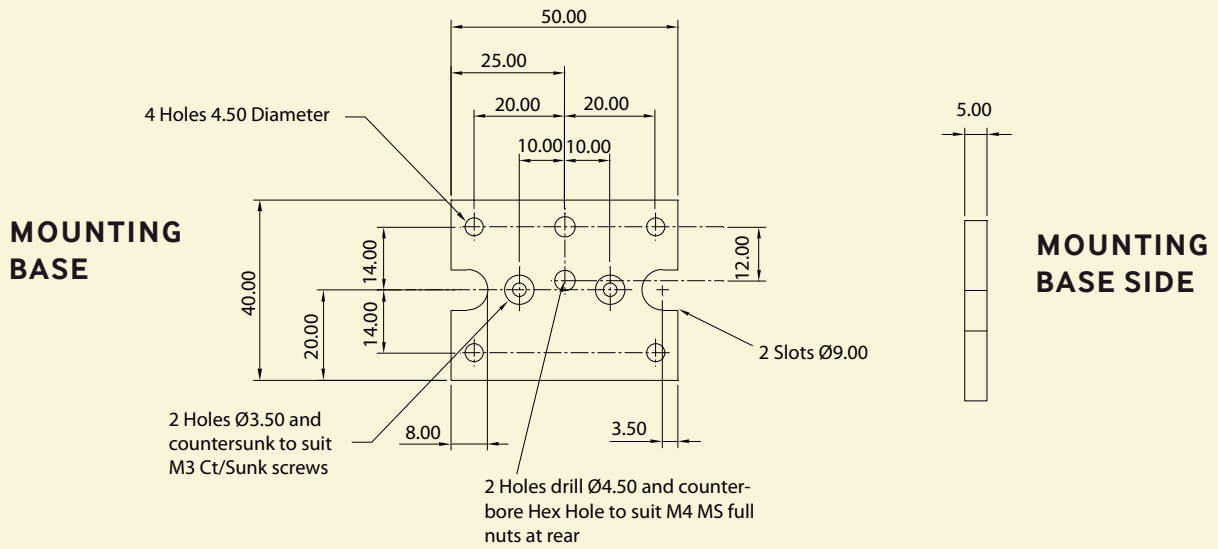
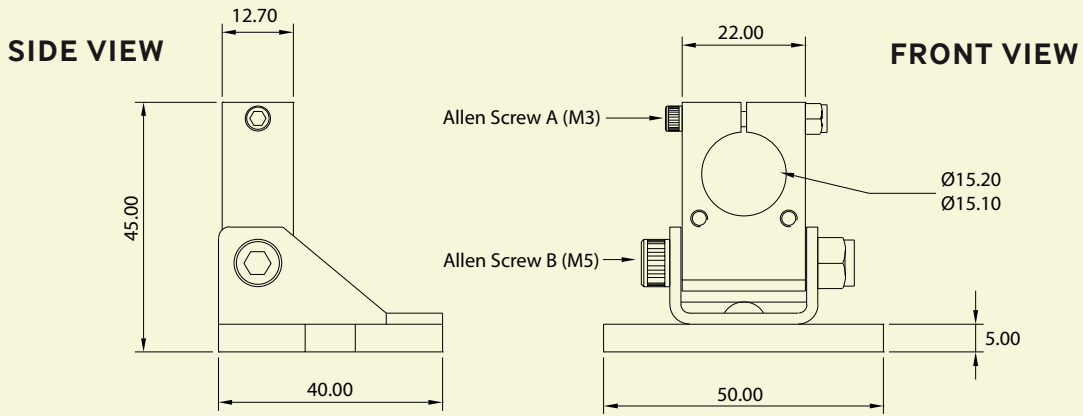

## F) Focus Key

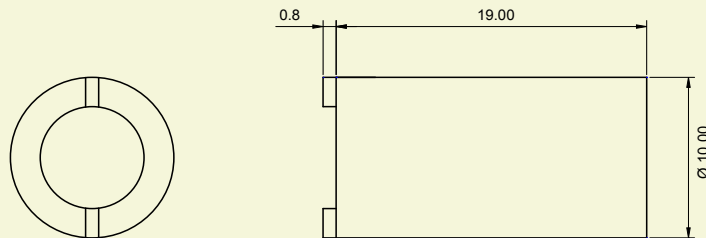

Drawings are not to scale.

For further information about any of our products please contact your local distributor or you can contact Global Laser in the UK. Your Local Distributor Is:

Please Note: Global Laser reserve the right to change descriptions and specifications without notice.



9090-02-052 Rev 2 08/05/213

T: +44 (0)1495 212213  
 F: +44 (0)1495 214004  
 E: sales@globallasertech.com  
 www.globallasertech.com

Global Laser Ltd  
 Unit 9-10  
 Roseheyworth Business Park  
 Abertillery, Gwent NP13 1LZ UK