

HVAC Application Overview

Solutions for Heating, Ventilation and Air Conditioning



TABLE OF CONTENTS

WAGO Building Application Solutions	04
Energy-Efficient Systems	06
HVAC Primary System Solutions	08
System Macros	12
<hr/>	
System Macros Overview	16
Generation	18
Distribution	22
Consumption	26
Utilization	38
<hr/>	
WAGO Services	40
Applications	42

WAGO BUILDING APPLICATION SOLUTIONS

Variety – Open Source – Cost Efficiency

WINSTA® – The Pluggable Connection System



High-Current, Rail-Mounted Terminal Blocks

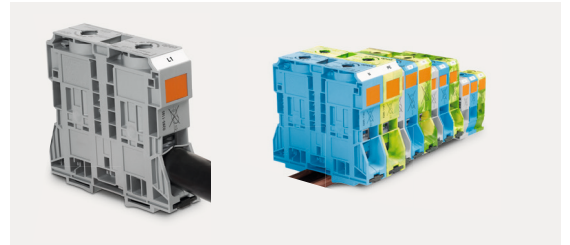

Installation Connectors



TOPJOB® S – The Rail-Mounted Terminal Block System

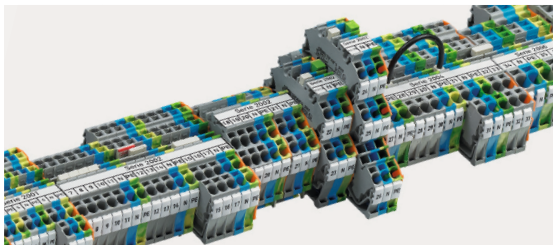

Distribution Boxes



Lighting Connectors

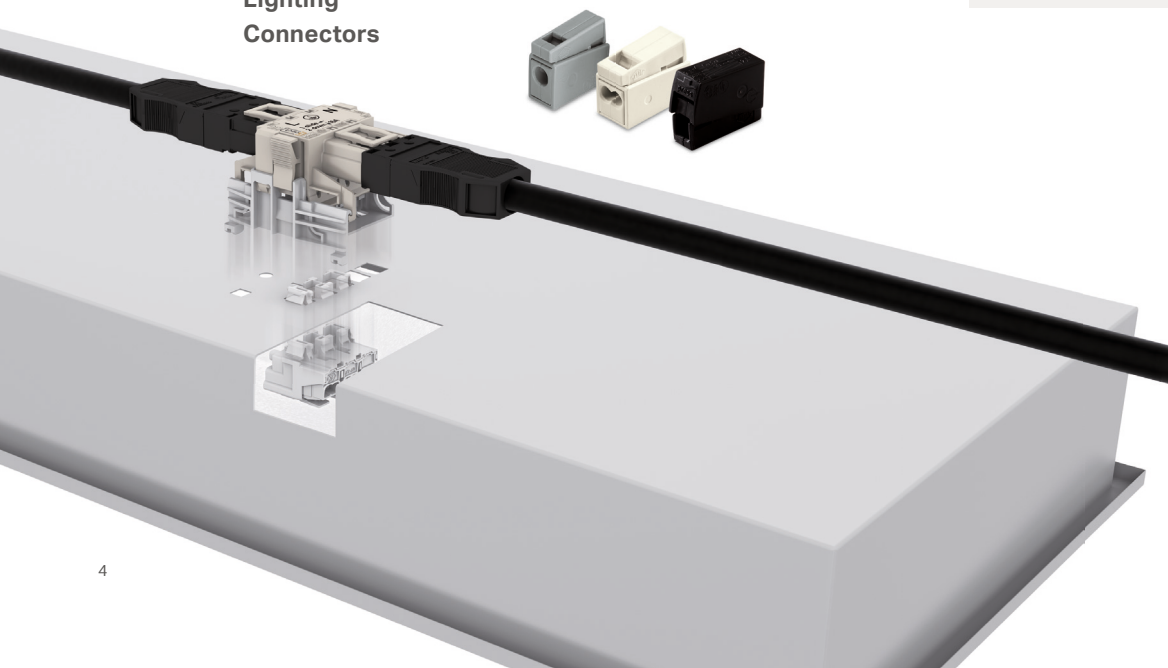

Interface Electronic and System components



WAGO-I/O-SYSTEM

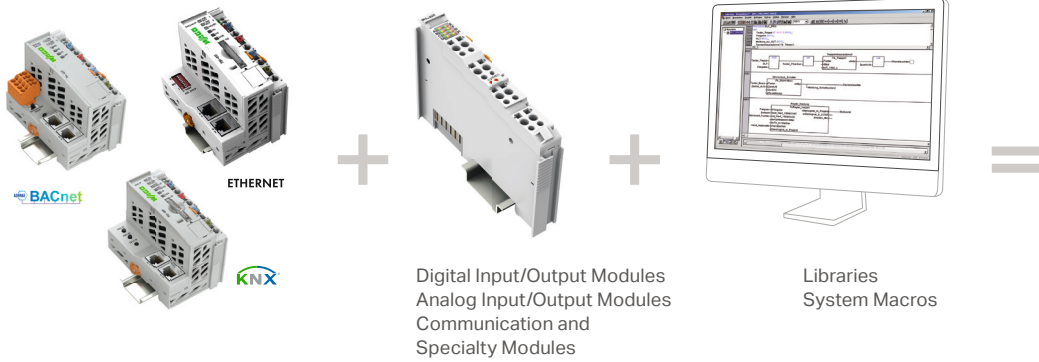

ETHERNET



DMX

ENERGY-EFFICIENT SYSTEMS

Potential Energy Savings via HVAC Automation

Leveraging Potential Energy-Savings

Efficient energy consumption, optimal system operation and continuous improvement are just a few requirements that buildings must continue to meet – even after construction or renovation. Beyond rental prices, potential tenants must factor operating costs for energy and maintenance into the bottom line. Therefore, it pays to look closely at the main factors behind building energy costs. Take for example the German market, in which heating and cooling applications account for 57.3 % of total energy consumption. And of that, 51.7 % is devoted to room heating – making it the country's largest energy consumer. With these unsustainable energy consumption levels driving the transition to renewable energy, savvy system planners are looking closely at the boiler room. Approximately 20 % of Europe's final energy consumption could be saved by doubling boiler room energy efficiency via system-specific measures or by improving the energy efficiency of the building envelope. A key part of the solution lies in system-related applications. The measure of success here depends on leveraging the huge

potential for savings through modernizing outdated heating technology. *

European nations have begun enacting policies to promote conservation, such as the new German Energy Saving Regulation (EnEV) that was enacted on May 1, 2014. Building contractors starting new construction projects must comply with this regulation. These new energy-saving guidelines are also applicable to building technology systems: heating, cooling, ventilation and lighting, as well as hot water supply.

The following parameters are used for determining energy efficiency:

- Annual primary energy demand for systems engineering
- Thermal insulation of the outer shell
- Heat protection/summer thermal insulation
- Air-tightness of the outer shell
- Minimum air exchange in residential buildings

*Source: "Green Paper on Energy Efficiency or Doing More with Less" (March 2006)

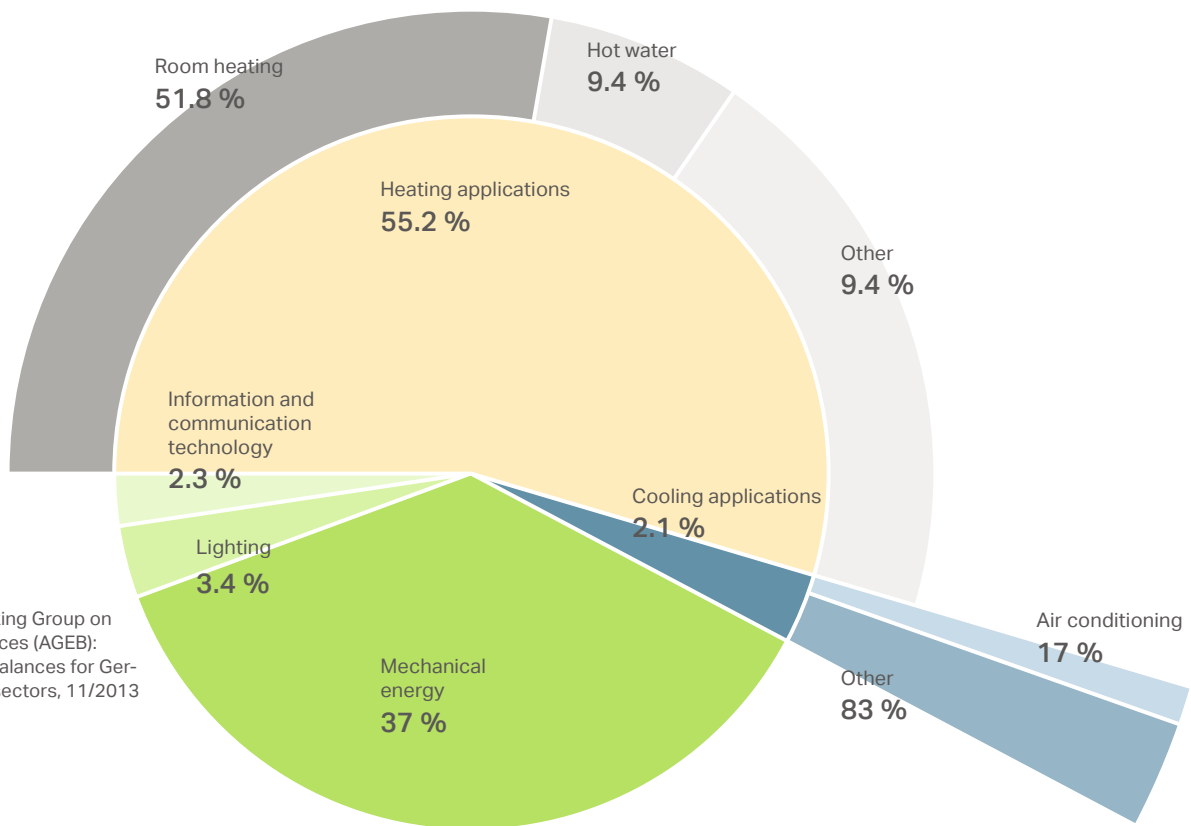

Source: Working Group on Energy Balances (AGEB): Application balances for German energy sectors, 11/2013

One basic requirement for planning a building's technical systems: Everyone who participates in the construction shares a common and clear language. To accomplish this, the DIN EN ISO 16484-3 Standard, which outlines building automation and control systems, is a core component of the initiative.

Furthermore, the DIN EN 15232:2012 Standard (Energy Performance of Buildings – Impact of Building Automation, Controls and Building Management) involves extensive calculations and simulations to assess the potential savings that could stem from modernization through automation. In offices, this standard allows up to 25 % heating-energy savings to be economically generated through building and room automation – without changing the building envelope.

Users and system operators can have a major influence on energy consumption through automation. Examples include integrating an automated system switch-off (when not needed), or by intelligently adapting a room temperature and

timer program to mirror room occupancy. These automated control functions enable you to fully exploit – and benefit from – potential savings. Therefore, combining HVAC macros with other CODESYS function blocks enables users to merge virtually every building system into one cohesive plan that effectively economizes the entire building.

INFO

eu.bac is the European Building Automation and Controls Association and represents the European manufacturers for Home and Building Automation and Energy Service Companies. WAGO's eu.bac membership demonstrates its commitment and expertise in automation and controls.





© sssss1gmel /panthermedia.net

HVAC PRIMARY SYSTEM SOLUTIONS

An Efficient Process: Step-by-Step

Energy efficiency hinges on sensibly planning of a building's technical systems. Modern automation systems conveniently combine all possible protocols and interfaces into one system – as opposed to the requirements of larger properties with mixed forms.

The WAGO-I/O-SYSTEM 750 is the ideal hardware package for this challenge. The controller, which takes on control tasks for building automation, can be easily expanded using bus modules from a variety of systems — virtually any device can be connected to the system. Configuration, programming and visualization are easily performed using WAGO's available software packages.

In addition to building automation, WAGO has a well-established track record in building installations. This experience is reflected in WAGO's integrated approach that cost-effectively combines these two worlds..

NOTE

WAGO-I/O-SYSTEM:

- **Modular design**
- **Fieldbus-independent**
- **Planning freedom via flexible solutions**
- **Future-ready, scalable solution**

Universal, Compact, Economical – WAGO-I/O-SYSTEM

Optimized for process-oriented communication, the WAGO-I/O-SYSTEM offers scalable performance and high integration density with an unbeatable price/performance ratio.

At the management level, building automation is an integral part of both cost and facility management; it's also a key component in overall building control. Open protocols link higher-level functions and building automation. To make the most of these protocols, WAGO offers software tools for commissioning and diagnostics to optimally support both system engineering and monitoring. Access to the Web visualization of each individual control unit is also performed at this management level.

ETHERNET has long-established itself as the dominant medium at the automation level. As such, WAGO's control units can be easily and efficiently

interlinked using open, standardized bus protocols for building automation (e.g., BACnet IP, KNX IP or Modbus/TCP). Standardized protocols and fast ETHERNET data transmission provide interoperable and future-ready interfaces between individual building technologies and levels.

Depending on the application, building automation systems can vary greatly from one building level to the next, requiring different transmission media (wired or wireless) and interfaces. Thus, flexible and easy-to-install media are required on the field level (room level).

This is why WAGO offers a wide variety of solutions ranging from the direct control of standard sensors and actuators via interfaces to two-wire subsystems (e.g., DALI, BACnet MS/TP, KNX TP1 or LonWorks®), on through to radio-based solutions such as EnOcean or Bluetooth®.

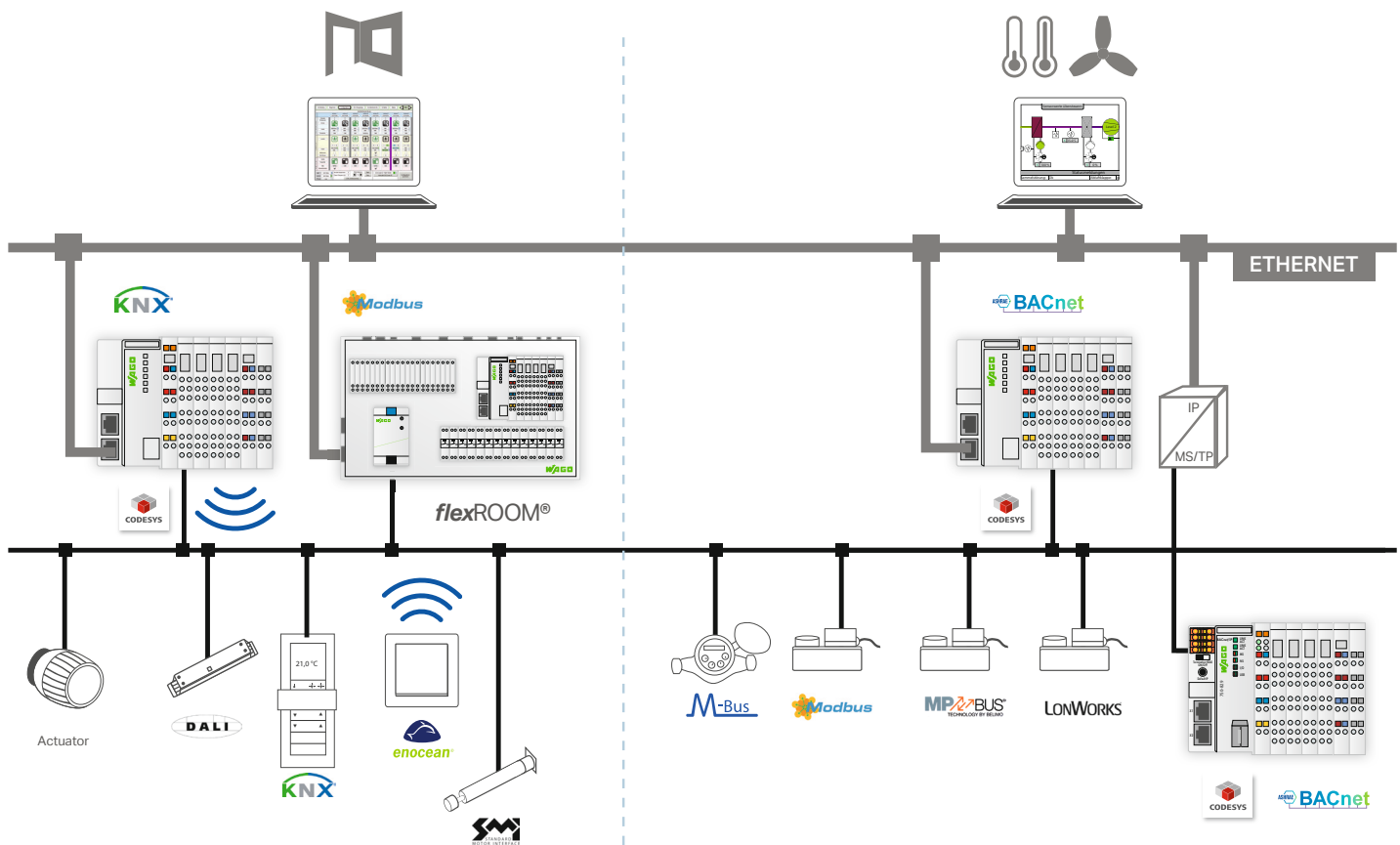

For more information on BACnet, visit: www.wago.com/bacnet

HVAC PRIMARY SYSTEM SOLUTIONS

Universal, Compact, Economical – The WAGO-I/O-SYSTEM

Analog Input Modules

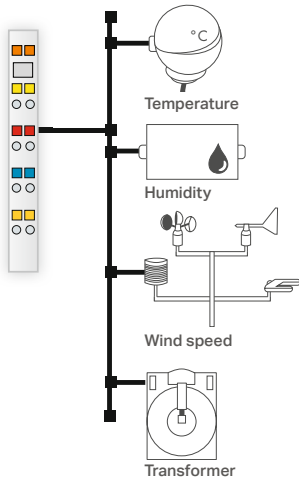

Analog Output Modules

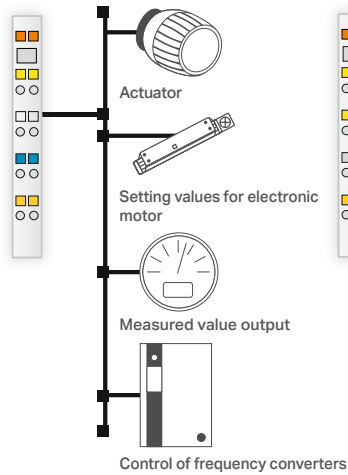

Digital Input Modules

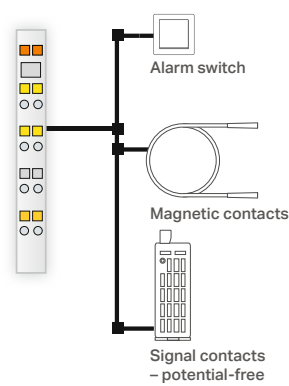

Digital Output Modules

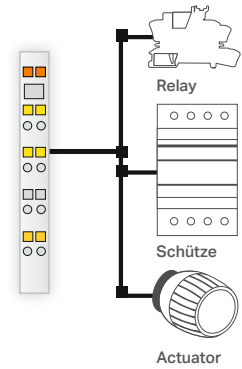

Communication Module

RS-232 C/RS-485

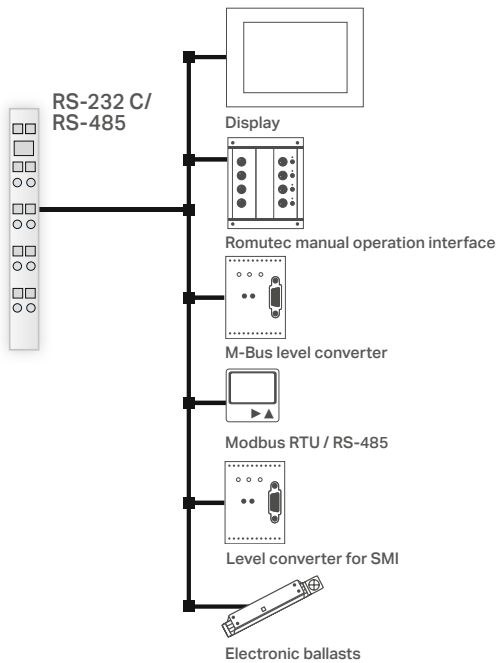

Specialty Modules

MPA-BUS[®]
TECHNOLOGY BY BELIMO

KNX[®]

LONWORKS



Basic WAGO Software



WAGO-I/O-CHECK

WAGO-I/O-CHECK is an easy-to-use Windows® application for checking inputs and outputs, as well as displaying a WAGO-I/O-SYSTEM 750 node.

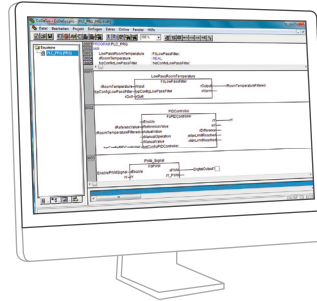

WAGO-I/O-PRO V 2.3

Using WAGO-I/O-PRO, programs can be individually created. In addition, pre-designed function blocks can also be accessed from software libraries. Graphically structured programs, such as those created with the Function Block Diagram (FBD) programming language, are very easy to create.

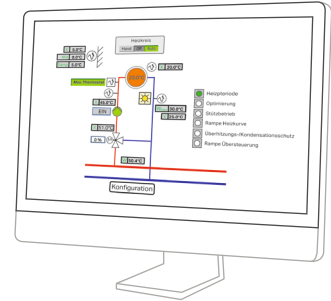

HVAC System Macros

With system macros, WAGO provides comprehensive modules with pre-configured functions to its customers; this dramatically streamlines project design and deployment by making most programming unnecessary.

Web Visualization

Project-specific visualizations are generated in the WAGO-I/O-PRO V 2.3 Software's editor. The Web visualization can also be accessed on a tablet or smartphone using an app.

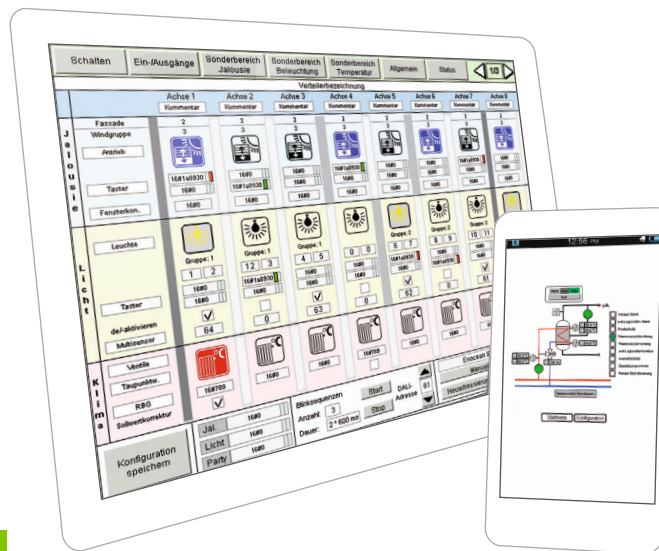

BENEFITS

- Ready-to-use applications
- Economize system commissioning
- Reuse standardized solutions
- Customize via open source macros
- No extensive programming required

BACnet and MODBUS Configurator

WAGO also offers tools specifically engineered for select technologies, applications and products. Among these is WAGO's BACnet and MODBUS Configurator, which allows devices connected to a specific network to be easily and efficiently addressed and parameterized.



SYSTEM MACROS

Parameter Setting – Not Programming

System Macros

WAGO provides comprehensive templates, which include readymade system macros for many common applications. This timesaving convenience minimizes HVAC configuration for users. After rapidly configuring the application – via simple data point and system parameter assignment – the ready-made application can be directly commissioned.

To simplify programming, there are a multitude of pre-configured function blocks and applications available free of charge in the download area. In addition, there are templates for creating programs. These comprehensive examples of complex tasks – including functional system macros with the appropriate documentation – are available in PDF format.

The manual override function within the system macros allows the operator to override individual system parts using the visualization screens.

**All current libraries and application notes
can be downloaded at:
www.wago.com/hvacdownload**



A system macro consists of various function blocks that are linked to other to enable the control of an entire ventilation system, for example. The function blocks consist of sub-functions that are combined to allow control of a larger task, such as a heating circuit.

Using a system macro, you can also display and configure the entire system in a visualization interface.

NOTE

Open Source! System macros are available as “open source” and can be tailored to meet individual system demands.

SYSTEM MACROS

Parameter Setting – Not Programming

System Diagram

Matching the applications, standardized system diagrams for CAD and TRIC are available for easy integration into current plans.

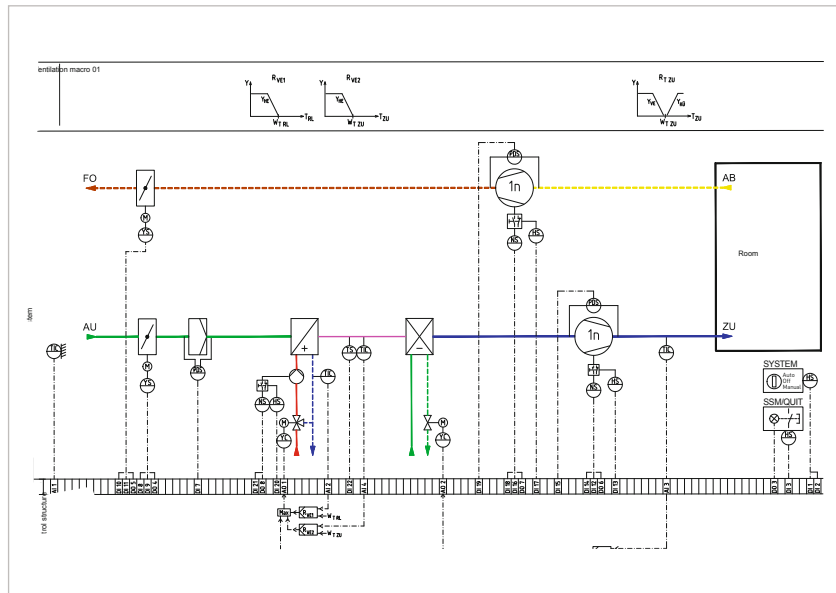

FbHeatingCircuitControl	
xManual	xPump
xAuto	rY_MixingValve
xSwitchOnComfortMode	wY_MixingValve
tTimeBeforeOperation	xErrorPump
rRoomTemperature	xHeatingCircuitActive
rReferenceComfortTemperature	xHeatingPeriod
rOutsideTemperature	xOptimization
rSupplyTemperature	xComfortMode
rReturnTemperature	xSupportMode
rDampedOutsideTemperature	xOverride
rAveragedOutsideTemperature	xChimneySweep
xPriorityDHWPreparation	rReferenceRoomTemperature
xOverheatingProtection	rReferenceSupplyTemperature
xChimneySweepFunction	rMaxReturnTemperature
xMaximalThermostat	xRamp
xManualSwitchPump	xRampOverride
rManualValueValve	dwOperationHoursPump
xMotorProtectionPump	
tpConfigHeatingCircuit	
tpConfigStartStopOptimization ▶	
dwOperationMinutesPump ▶	

Graphical Function Block Representation

Using the graphical function block representation, a macro's functions can be clearly displayed to simplify assembly.

System Macro Components

Configuration Visualization

The configuration interface is divided into several sections:

- Room temperature:** Includes checkboxes for 'Room temperature sensor' and 'Overnight shutdown', and input fields for 'Lowered room temperature' (14.0 °C), 'Room temperature, support mode' (13.0 °C), and 'Hysteresis, support mode' (2.0 K).
- Override function:** Includes 'Enable override' checkbox, 'Ramp, decrease, DHW priority' checkbox, 'Maximum time, DHW priority' (T#80m0s0ms), 'Supply temperature, overheating protection' (70.0 °C), and 'Override function ramp' (3.0 K/min).
- Supply temperature controller:** Includes 'Kp supply temperature controller' (10.0), 'Tn supply temperature controller' (800 [s]), 'Dead band' (0.5 [K]), and 'Limit temperature, antifreeze protection' (10.0 [°C]).
- Supply temperature calculation:** Includes 'Heating curve gradient' (1.8), 'Heating curve curvature' (1.3), 'Minimum supply temperature' (20.0 [°C]), 'Maximum supply temperature' (80.0 [°C]), and 'Supply temperature ramp' (1.0 [K/min]). A graph shows supply temperature vs. outside temperature.
- Pump and mixing valve:** Includes 'Winter mode' checkbox, 'Min. outside temp. Pump ON' (5.0 [°C]), 'Lag time, pump' (T#15m0s0ms), 'Set value, chimney sweep function' (25 [%]), 'Max. time, chimney sweep function' (T#30m0s0ms), 'Jam protection' checkbox, 'Max. turn-off time' (T#2880m0s0ms), and 'Runtime, pump + valve' (T#1m0s0ms).
- Heating limit, comfort:** Includes 'Heating limit, damped outside temp.' (18.0 [°C]) and 'Heating limit, averaged outside temp.' (16.0 [°C]).
- Heating limit, standby:** Includes 'Heating limit, damped outside temp.' (18.0 [°C]) and 'Heating limit, averaged outside temp.' (16.0 [°C]).
- Optimization characteristic curves:** Includes 'Start optimization' checkbox, 'Stop optimization' checkbox, 'Max. optimization time' (T#540m0s0ms), 'Hysteresis' (0.5 [K]), 'Holiday offset' (30 [%]), 'Start time at -10°C' (T#50m0s0ms [h:k]), 'Start time at +10°C' (T#20m0s0ms [h:k]), 'Stop time at -10°C' (T#0ms [h:k]), and 'Stop time at +10°C' (T#20m0s0ms [h:k]).
- Return temperature limiter:** Includes 'Return limit controller' checkbox, 'Min. outside temperature, return control' (-10.0 [°C]), 'Max. outside temperature, return control' (10.0 [°C]), 'Minimum setpoint for return temperature' (25.0 [°C]), 'Maximum setpoint for return temperature' (45.0 [°C]), 'Kp return temperature controller' (10.0), and 'Tn return temperature controller' (200 [s]).

In addition to a visualization of the selected application, macros allow the user to easily adjust all relevant parameters through an online graphical interface.

System Visualization

The system visualization interface displays a detailed schematic of the heating system. It includes various components such as pumps, valves, sensors, and actuators. A 'Manual Off Auto' control panel is visible, along with 'Overriding sensor values'. The system is currently in 'Auto' mode. A 'Status messages' table is shown at the bottom, providing real-time feedback on system components.

Status messages			
Collective malfunction:	Ok	Incoming air fan:	OK
Preflushing:	Completed	Exhaust air fan:	OK
Mixed air damper:	ON	Humidifier:	OFF
Exhaust air damper:	Open		

Buttons for 'Start page' and 'Configuration' are located at the bottom of the interface.

Furthermore, the macros contain complete visualization interfaces for each completed application that allow you to monitor and control functions via the controller's embedded Webserver.

APPLICATION NOTE

In addition to these graphical representations, the application note also includes a comprehensive function description, hardware information and a detailed tabular function block description.

SYSTEM MACROS OVERVIEW

Parameter Setting – Not Programming

Page 18-19

GENERATION DISTRIBUTION

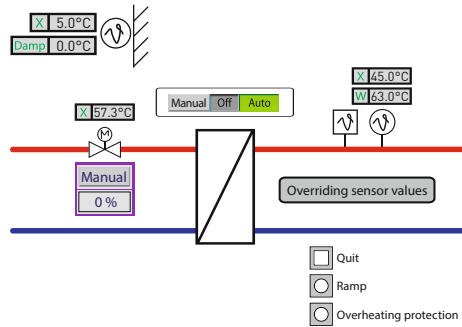

District Heating Transfer Station Macros

- District heating transfer station with supply temperature control and return temperature limitation

Page 20-21

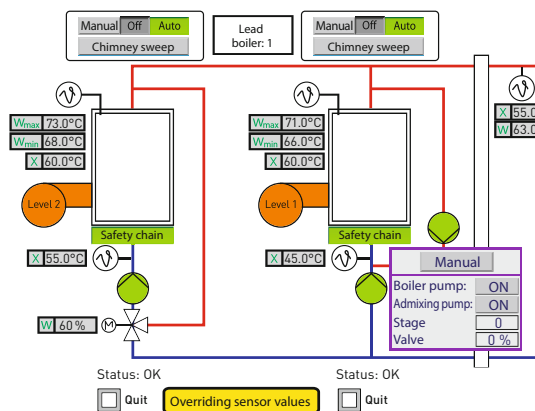

Boiler Macros

- Boiler strategy with two dual-stage boilers
- Boiler strategy with one dual-stage and one modulating boiler

Page 22-25

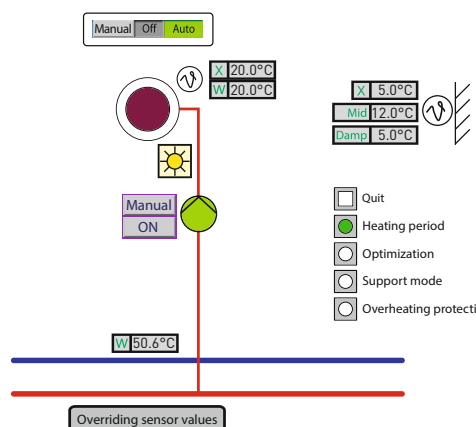

Heating Circuit Macros

- Heating circuit with circulation pump
- Heating circuit with heat exchanger, supply temperature control and return temperature limitation
- Heating circuit with supply temperature control and return temperature limitation

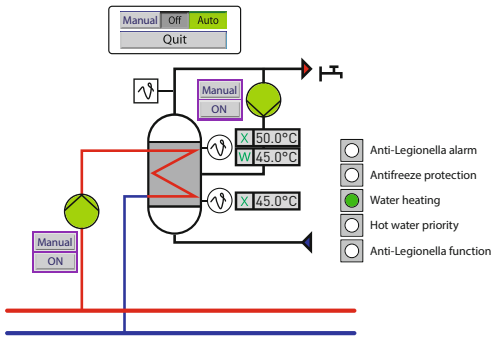

Domestic Water Heating Macros

- Domestic water heating with charging pump
- Domestic hot water production with heat exchanger
- Domestic hot water production with supply temperature monitoring

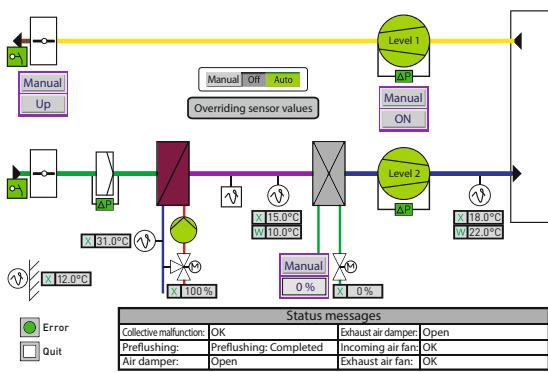

Ventilation Macros

- **Supply air temperature control or cascade control**
- Single-stage fan
- Dual-stage fan
- Mixed air fan with frequency converter
- Plate-type heat exchanger
- Run-around coil system
- Rotary heat exchanger

- **Full air-conditioning system**
- Fan with frequency converter
- Mixed air humidification and dehumidification



© Rawpixel.com/fotolia.com

Single-Room Control

- PID single-room controller



© koddapanthermedia.net

GENERATION

District Heat Macro

Heating Transfer Station with Supply Temperature Control and Return Temperature Limitation

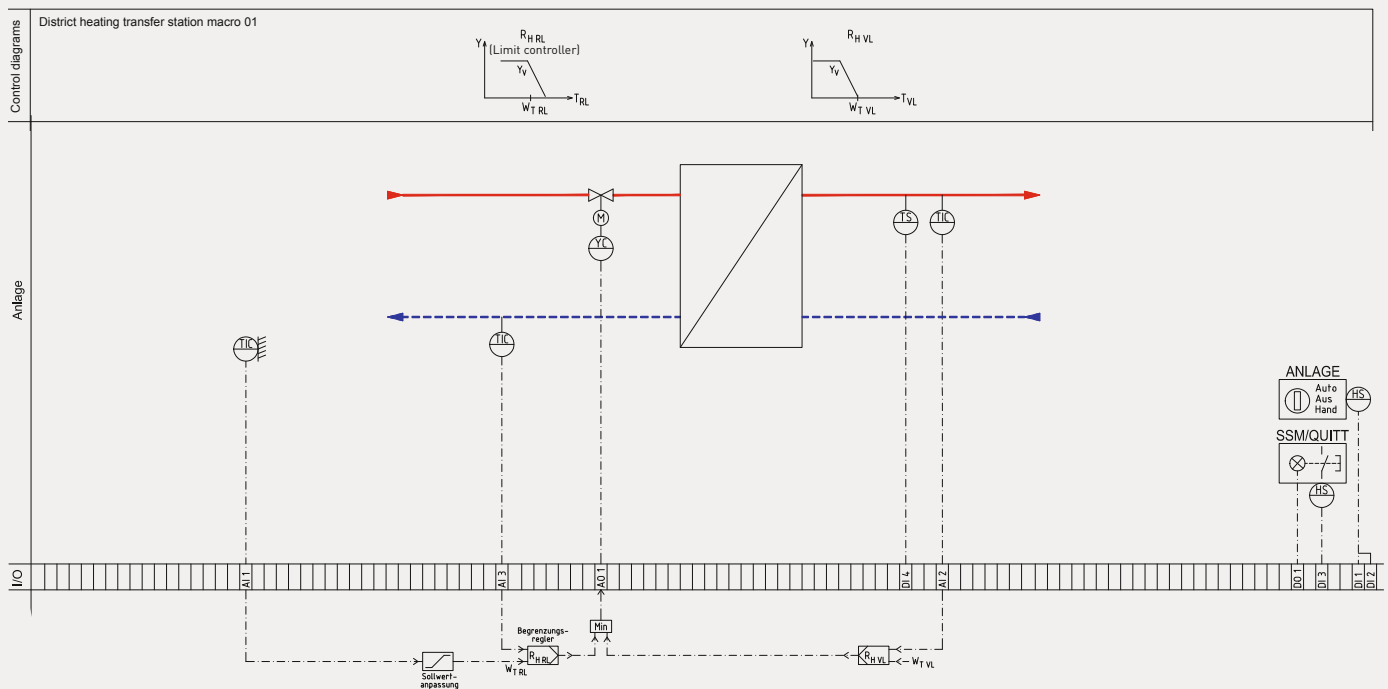

The following requirements are met:

- Supply temperature setpoint with ramp function (crack protection)
- Adjustable offset to the reference supply temperature
- PI supply temperature control
- Anti-jamming function for valve
- Return flow temperature limit based on outside temperature
- Overheating protection using maximum thermostat

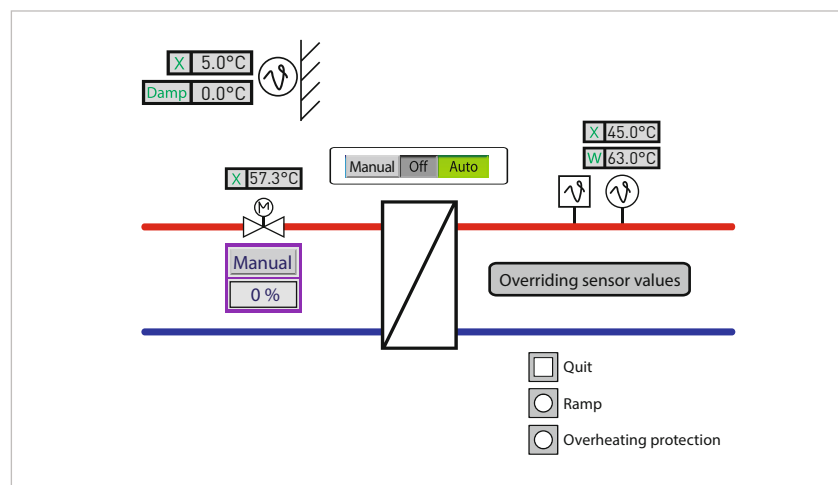

GENERATION

Boiler Macros

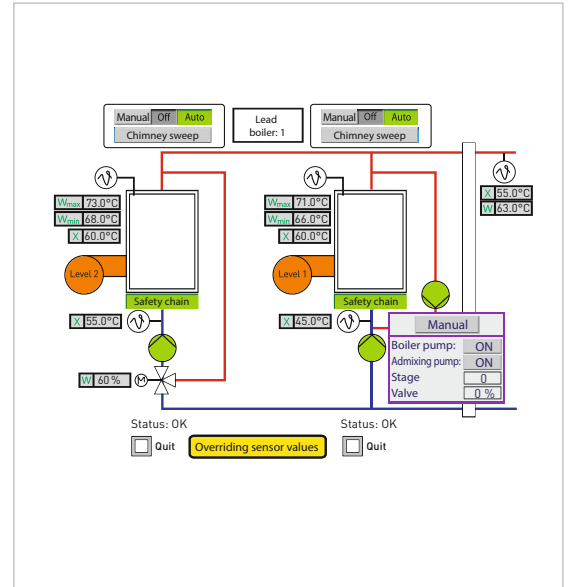
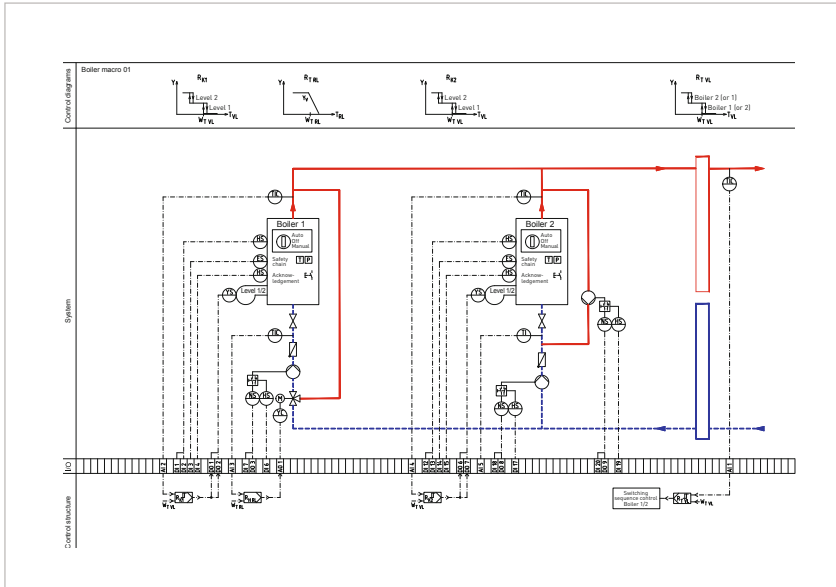

Boiler Strategy with Two Dual-Stage Boilers

BOILER STRATEGY

- Boiler strategy for two boilers
- Demand-dependent connection to the second boiler
- Dynamic switching of the lead boiler
- Automatic switching of the lead boiler in the event of a fault

BOILER CONTROL

- Maximum limit of the boiler supply temperature
- Minimum return flow temperature monitoring
- Maximum return flow temperature limit
- Unrestricted selection between mixing pump, 3-way valve and boiler damper
- Boiler anti-condensation protection
- Anti-jamming function for pumps and valve
- Differing parameters for lead boiler and lag boiler
- Different start-up processes based on the components used

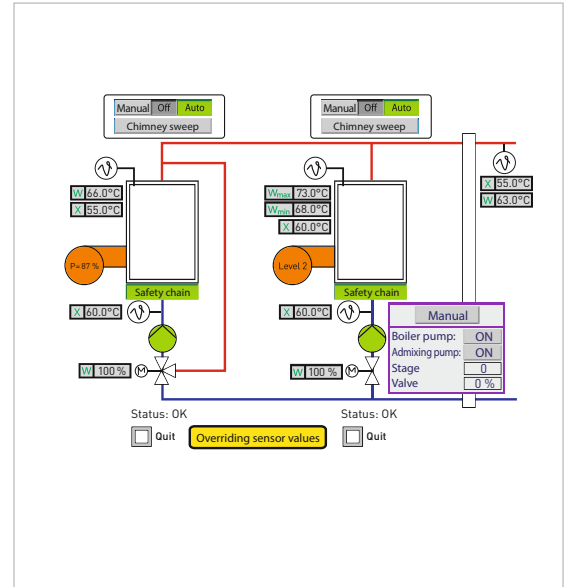
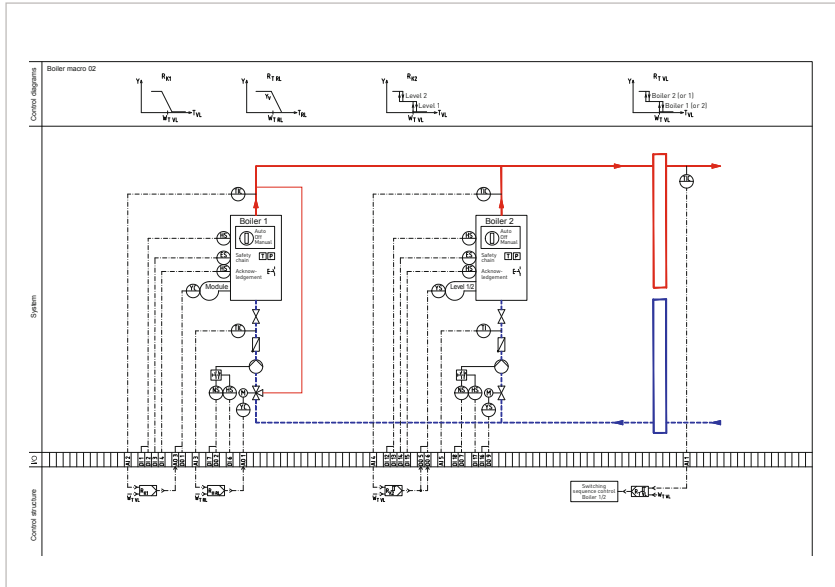

Boiler Strategy with One Dual-Stage and One Modulating Boiler

BOILER STRATEGY

- Boiler strategy for two boilers
- Demand-dependent connection to the second boiler
- During normal operation, the modulating boiler is always the lead boiler
- Automatic switching of the lead boiler in the event of fault

BOILER CONTROL

- Maximum limit of the boiler supply temperature
- Constant maximum limit of the boiler supply temperature for the modulating boiler
- Minimum return flow temperature monitoring
- Maximum return flow temperature limit
- Unrestricted selection between mixing pump, 3-way valve and boiler damper
- Boiler anti-condensation protection
- Anti-jamming function for pumps and valve
- Differing parameters for lead boiler and lag boiler
- Different start-up processes based on the components used



DISTRIBUTION

Heating Circuit Macros

Heating Circuit with Circulation Pump

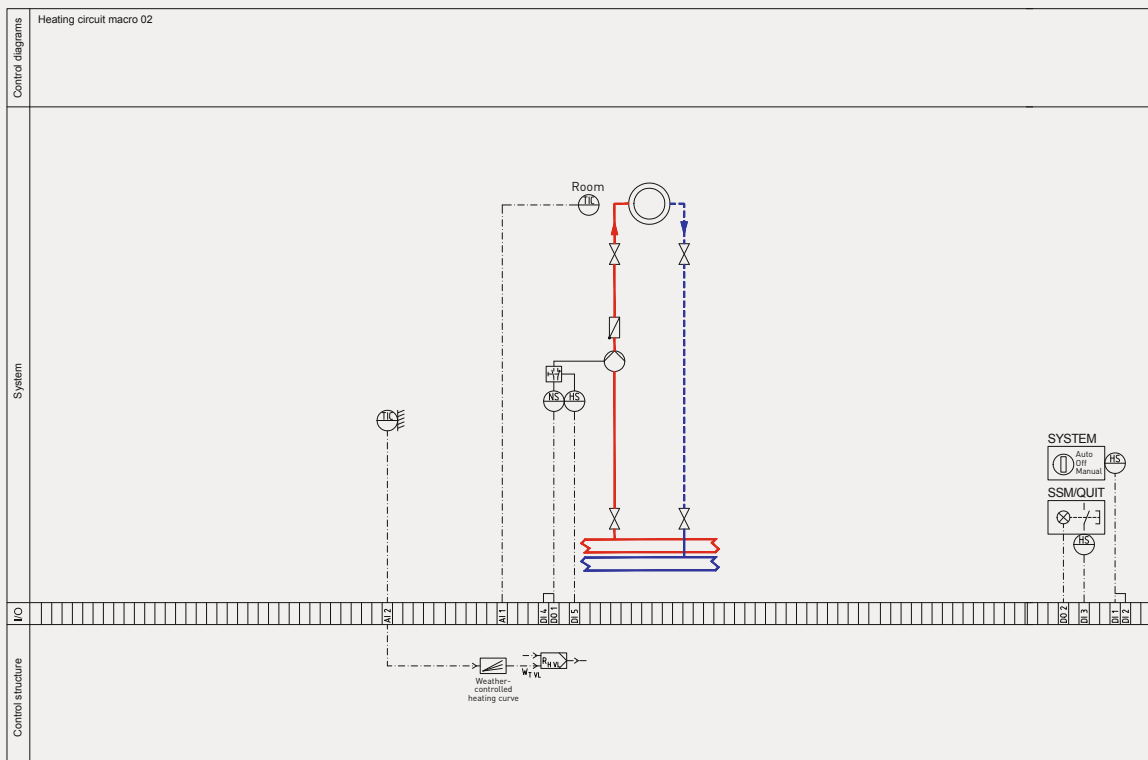

The following requirements are met:

- Heating limit dependent on outside temperature to determine heating periods
- Selection between overnight economy mode (parallel shift of the heating curve) and overnight shutdown (support mode)
- Self-regulating start optimization
- Heating curve
- Mandatory override (e.g., overheating protection of the primary system)
- Anti-jamming function for the pump

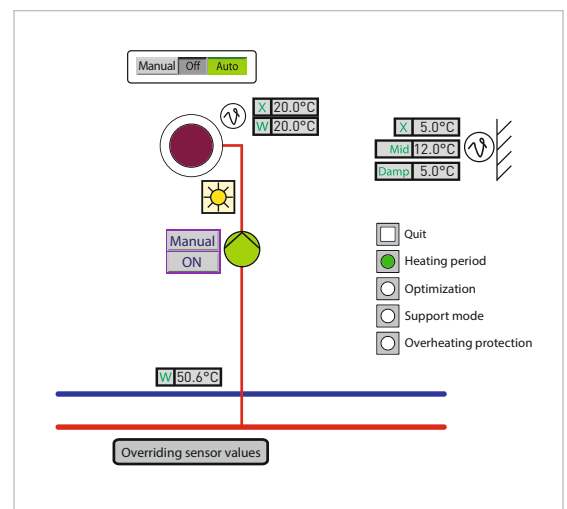

DISTRIBUTION

Heating Circuit Macros

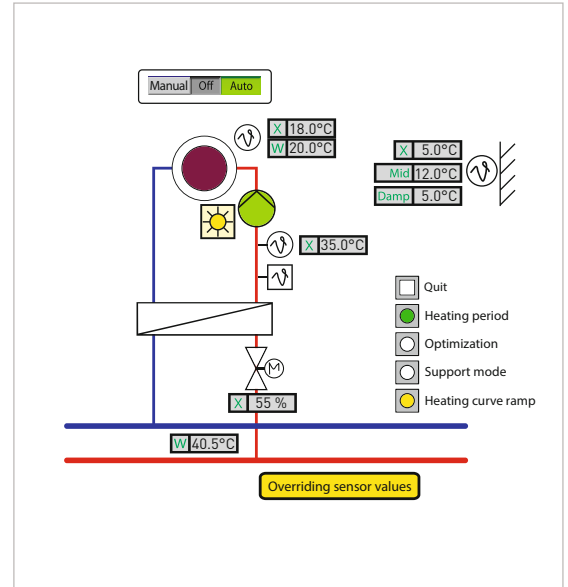
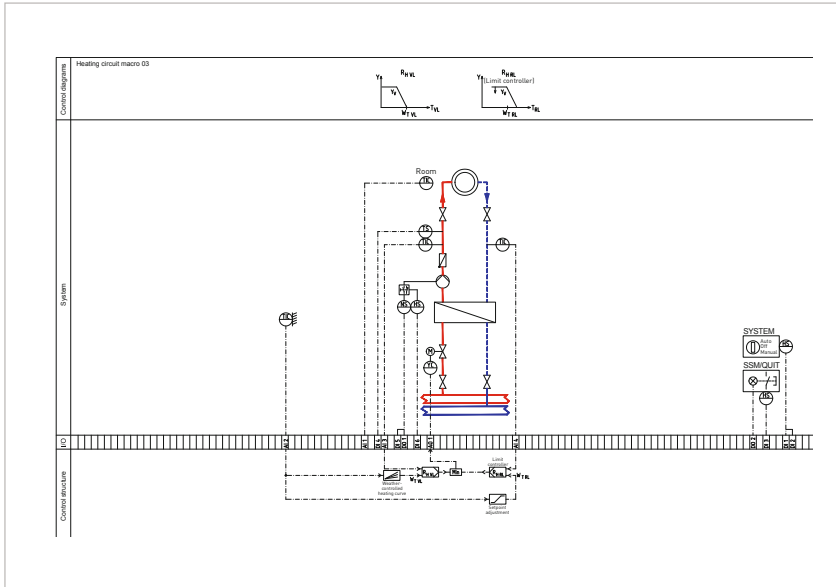

Heating Circuit with Heat Exchanger, Supply Temperature Control and Return Temperature Limitation

The following requirements are met:

- Heating limit dependent on outside temperature to determine heating periods
- Selection between overnight economy mode (parallel shift of the heating curve) and overnight shutdown (support mode)
- Self-regulating start optimization
- Heating curve
- Supply temperature setpoint with ramp function (crack protection)
- PI supply temperature controller
- Return flow temperature limit based on outside temperature
- Antifreeze controller
- Pump switch-on is demand-dependent
- Anti-jamming function for pump and valve

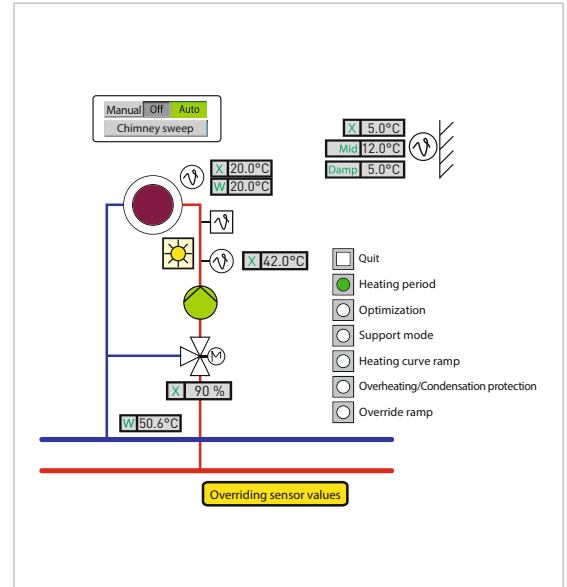
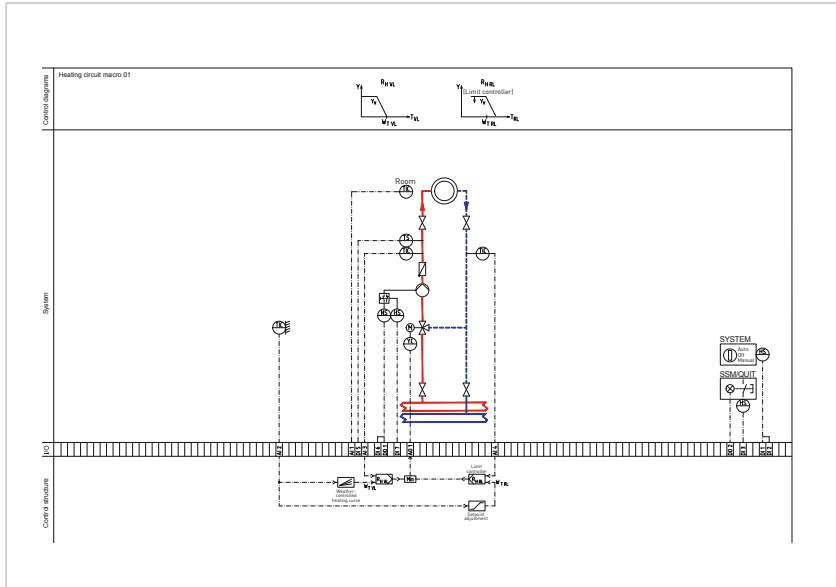

Heating Circuit with Supply Temperature Control and Return Temperature Limitation

The following requirements are met:

- Heating limit dependent on outside temperature to determine heating periods
- Selection between overnight economy mode (parallel shift of the heating curve) and overnight shutdown (support mode)
- Self-regulating start optimization
- heating curve
- Supply temperature setpoint with ramp function (crack protection)
- PI supply temperature controller
- Chimney sweep function with time limit
- Mandatory override (e.g., domestic water heating or overheating protection of the primary system)
- Return flow temperature limit based on outside temperature
- Antifreeze controller
- Pump switch-on is demand-dependent
- Anti-jamming function for pump and valve



CONSUMPTION

Domestic Water Heating Macros

Domestic Water Heating with Charging Pump

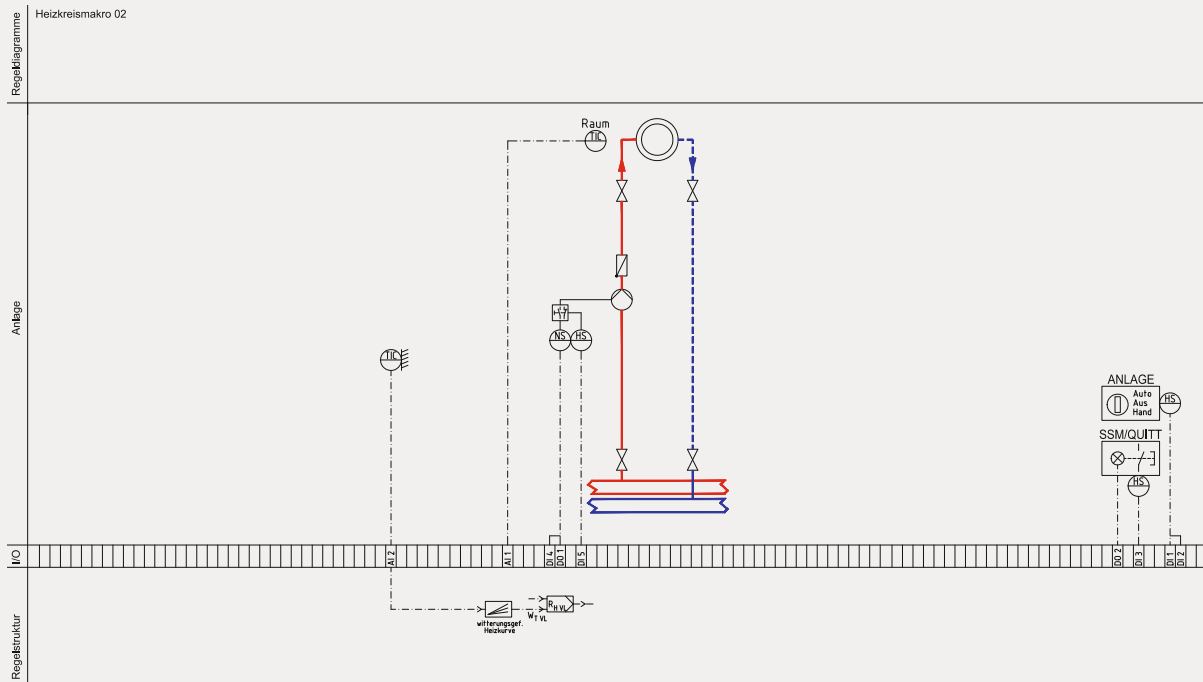

The following requirements are met:

- Two-point temperature control, corresponding to the upper and lower storage tank temperature sensors
- Anti-Legionella function
- Hot water priority function request
- Charging and circulation pump control
- Anti-jamming function for the pumps
- Supply temperature setpoint

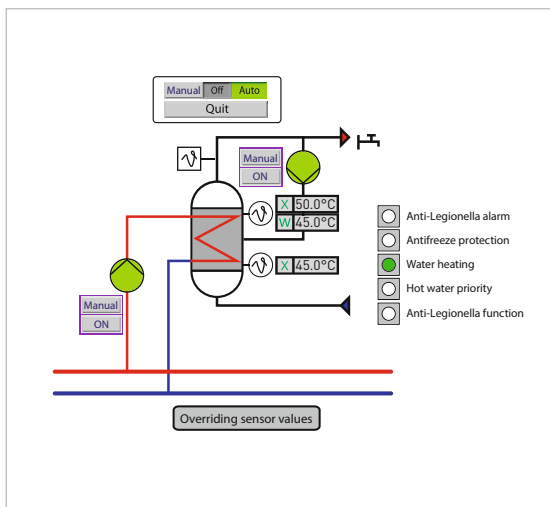

NOTE

Water tanks are prone to the formation of Legionella bacteria. To ensure the highest levels of safety and hygiene, WAGO domestic water heating macros are equipped with an anti-Legionella function. This mandatory function (heating to 70 °C) is activated by a timer program.

CONSUMPTION

Domestic Water Heating Macros

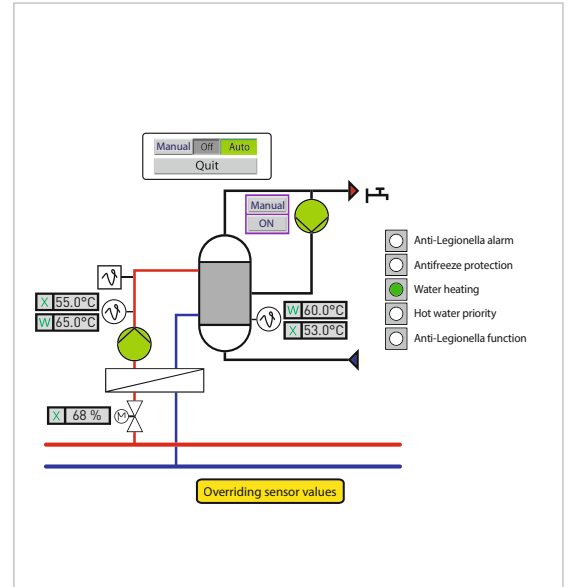
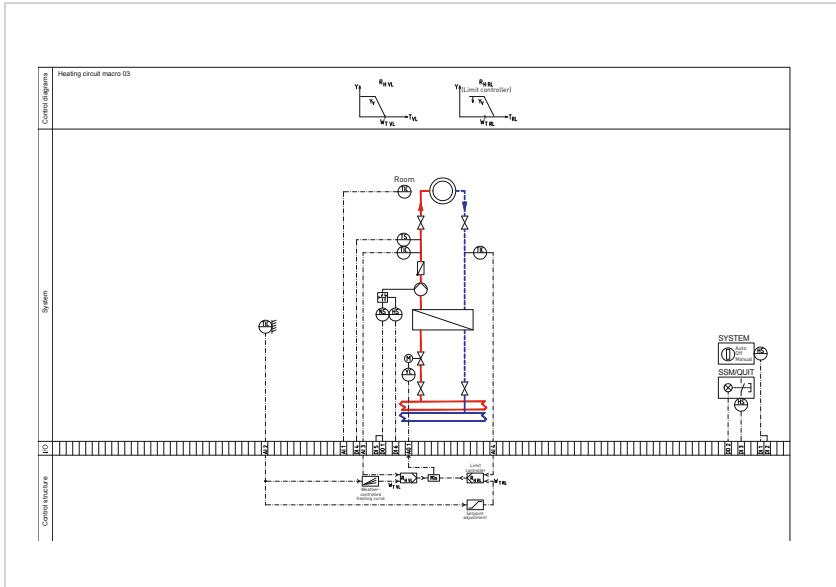

Domestic Water Heating with Heat Exchanger

The following requirements are met:

- Storage tank control using a two-point controller
- PI supply temperature control
- Anti-Legionella function
- Hot water priority function request
- Charging and circulation pump control
- Charging pump switch-on is demand-dependent
- Anti-jamming function for pumps and valve
- Supply temperature setpoint

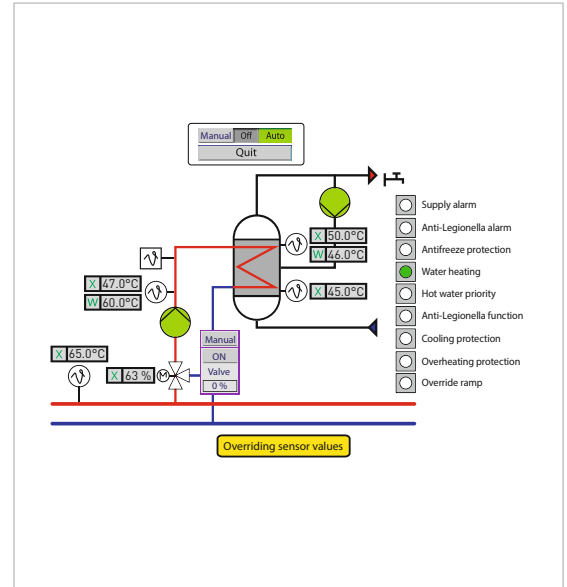
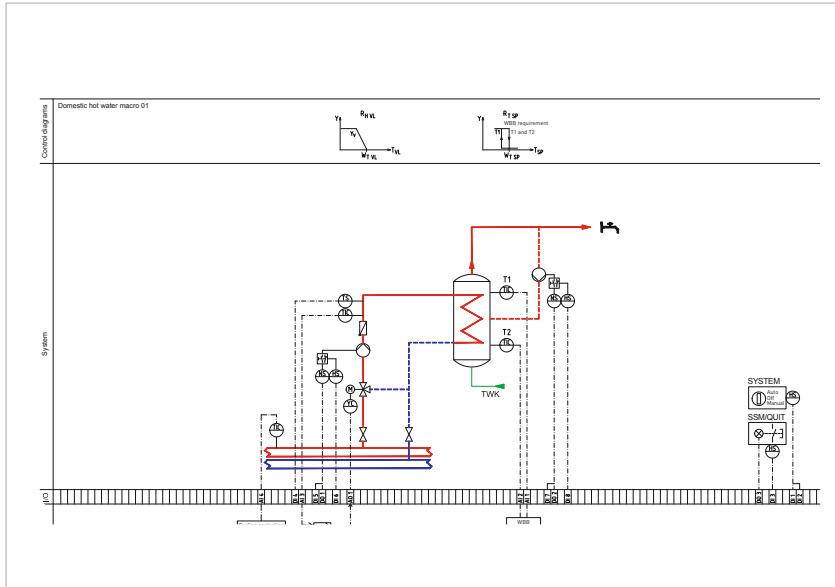

Domestic Water Heating with Supply Temperature Monitoring

The following requirements are met:

- Two-point temperature control, corresponding to the upper and lower storage tank temperature sensors
- Anti-Legionella function
- Cooling protection
- Mandatory override (e.g., overheating protection of the primary system)
- Hot water priority function request
- Charging and circulation pump control
- Charging pump switch-on is demand-dependent
- Anti-jamming function for pumps and valve
- Supply temperature setpoint

CONSUMPTION

Ventilation Macros

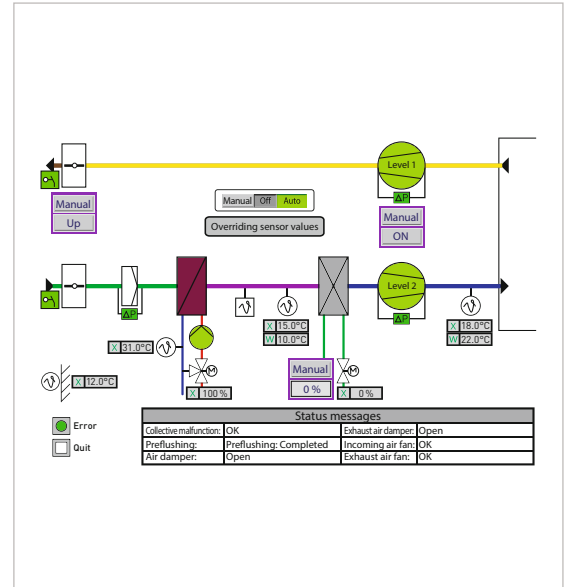
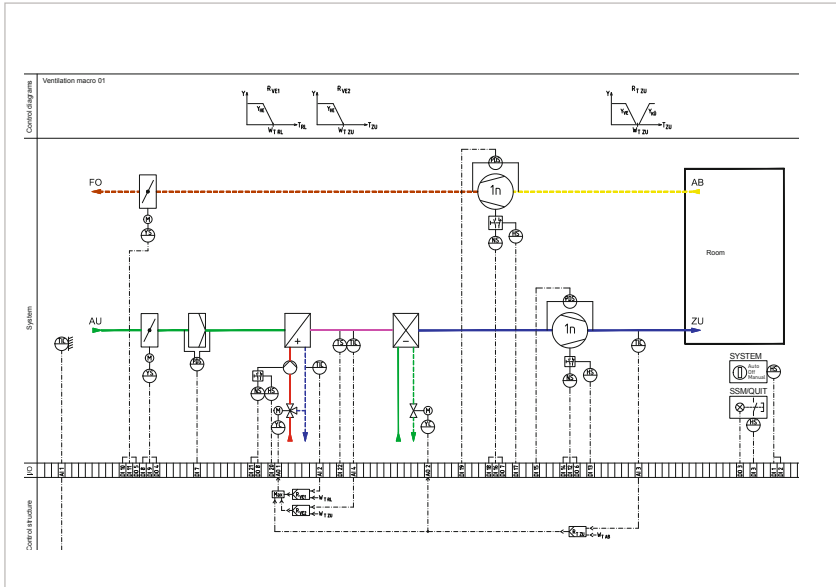

Supply Air Temperature Control with Single-Stage Fan

The following requirements are met:

- Single-stage fan with contactor and operational monitoring
- Upstream and downstream frost protection
- Switching-on the pumps is demand-dependent
- Anti-jamming function for pumps and valves
- Control of outside air and exhaust air dampers
- Monitoring the outside air filter
- Supply air temperature control with cooling/heating sequences
- Optimized setpoint supply temperature measurement

NOTE

Our ventilation macros meet the DIN EN 13779 standard – ventilation for non-residential buildings.

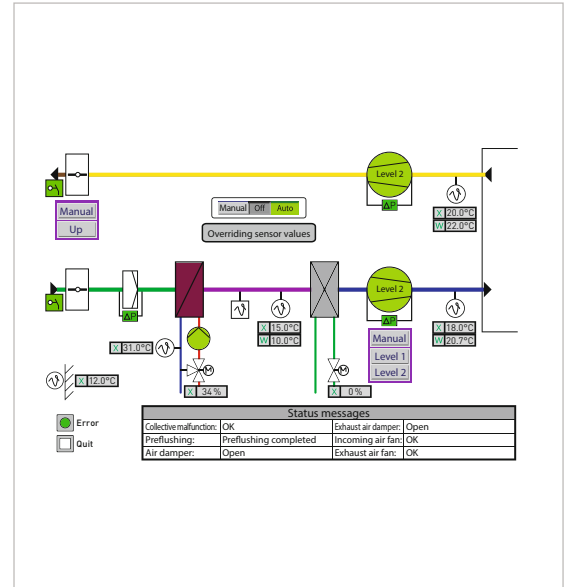
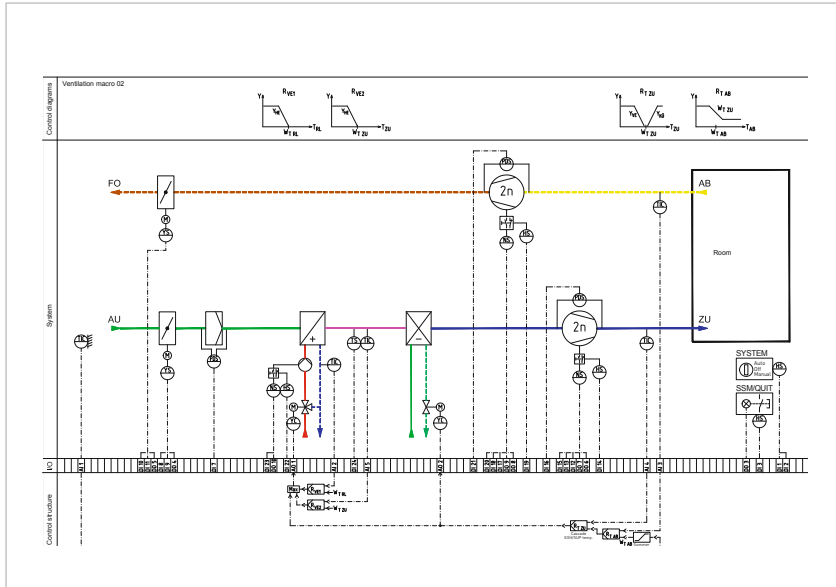

Cascade Control with Dual-Stage Fan

The following requirements are met:

- Dual-stage fan with contactor and operational monitoring
- Upstream and downstream frost protection
- Switching-on the pumps is demand-dependent
- Anti-jamming function for pumps and valves
- Control of outside air and exhaust air dampers
- Monitoring the outside air filter
- Energy-optimized room/exhaust temperature control with summer increase per DIN 1946
- Supply air temperature control with cooling/heating sequences
- Optimized setpoint supply temperature measurement

CONSUMPTION

Ventilation Macros

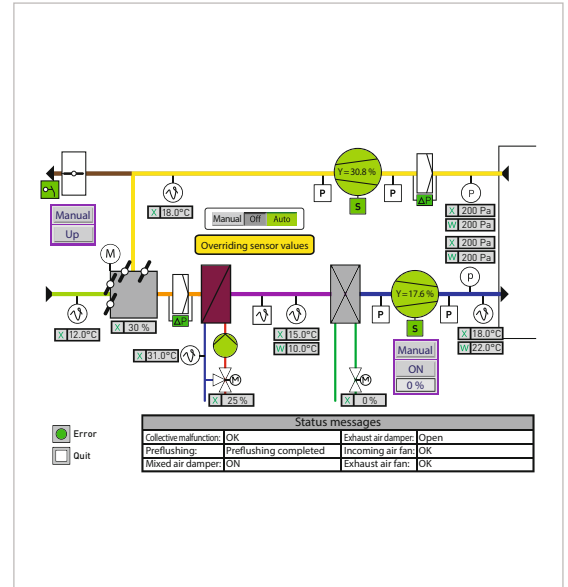
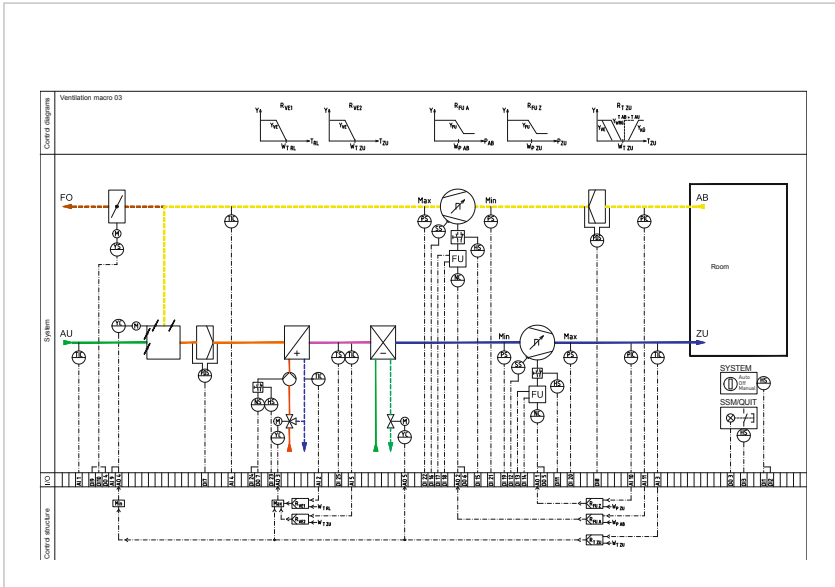

Supply Air Temperature Control with Mixed Air and Fan with Frequency Converter

The following requirements are met:

- Continuous fan with contactor and operational monitoring
- **Pressure control in supply and exhaust air duct**
- Upstream and downstream frost protection
- Switching-on the pumps is demand-dependent
- Anti-jamming function for pumps and valves
- Control of mixed air and exhaust air dampers
- Monitoring the outside air filter
- Supply air temperature control in **cooling/circulating/heating** sequences
- Optimized setpoint supply temperature measurement

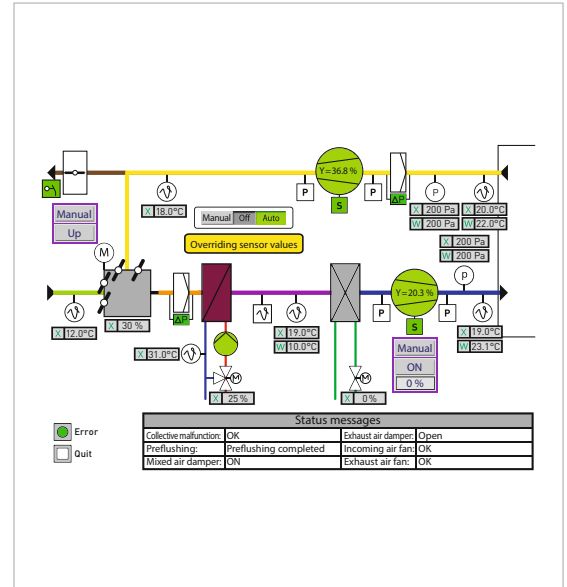
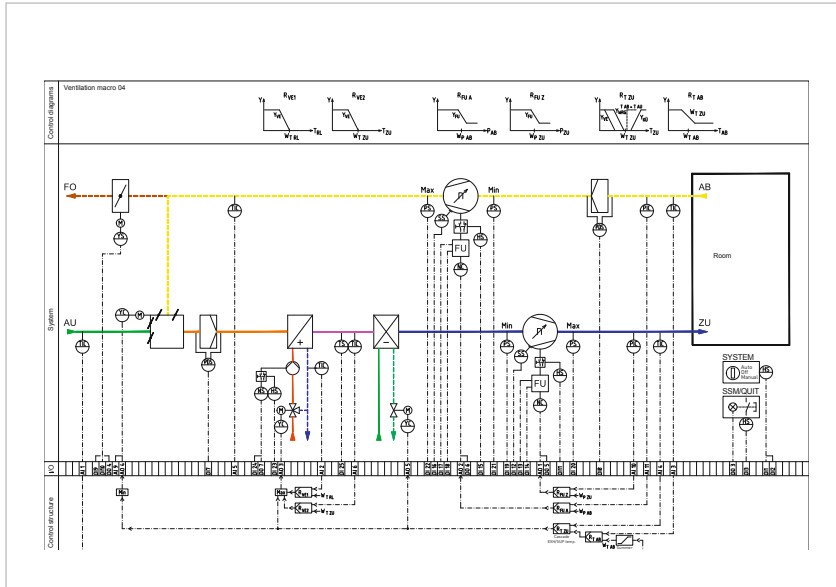

Cascade Control with Mixed Air and Fan with Frequency Converter

The following requirements are met:

- Continuous fan with contactor and operational monitoring
- **Pressure control in supply and exhaust air duct**
- Upstream and downstream frost protection
- Switching-on the pumps is demand-dependent
- Anti-jamming function for pumps and valves
- Control of mixed air and exhaust air dampers
- Monitoring the outside air filter
- **Energy-optimized room/exhaust temperature control with summer increase per DIN 1946**
- Supply air temperature control in cooling/mixed air/heating sequences
- **Summer night ventilation**
- Optimized setpoint supply temperature measurement

CONSUMPTION

Ventilation Macros

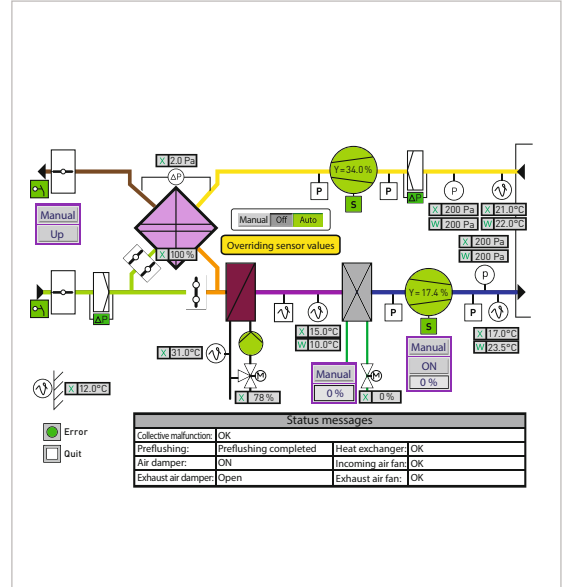
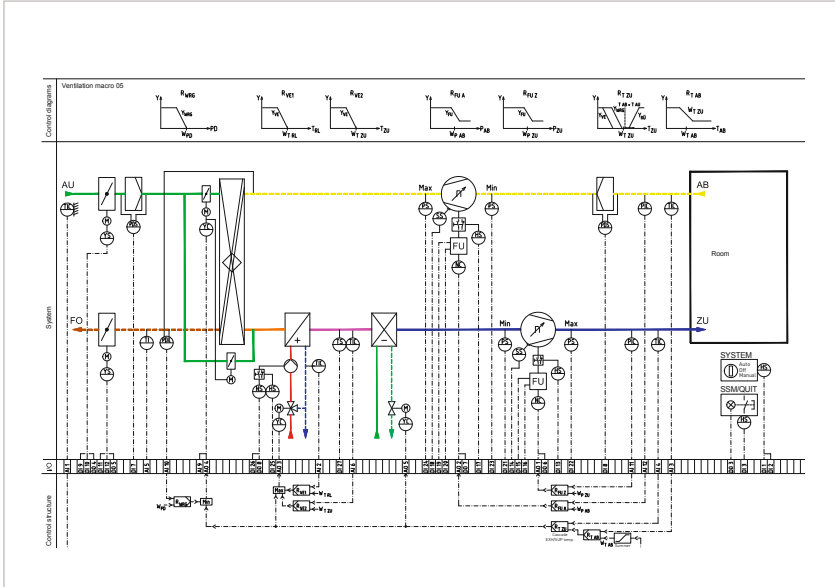

Cascade Control with Plate-Type Heat Exchanger and Fan with Frequency Converter

The following requirements are met:

- Continuous fan with contactor and operational monitoring
- Pressure control in supply and exhaust air duct
- Upstream and downstream frost protection
- Switching-on the pumps is demand-dependent
- Anti-jamming function for pumps and valves
- Control of outside air and exhaust air dampers
- Monitoring the outside air and exhaust air filters
- Energy reclamation using plate heat exchanger (cross-flow heat exchanger)
- Energy-optimized room/exhaust temperature control with summer increase per DIN 1946
- Supply air temperature control in cooling/energy reclamation/heating sequence
- Summer night ventilation
- Optimized setpoint supply temperature measurement

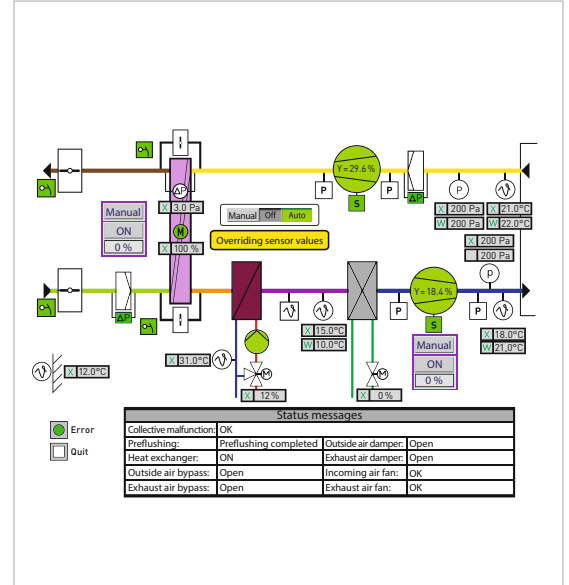
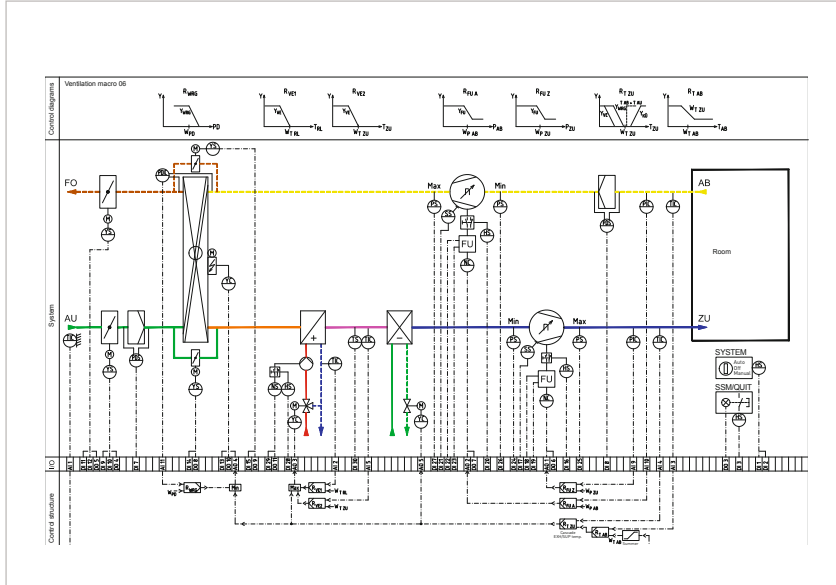

Cascade Control with Run-Around Coil System and Fan with Frequency Converter

The following requirements are met:

- Continuous fan with contactor and operational monitoring
- Pressure control in supply and exhaust air duct
- Upstream and downstream frost protection
- Switching-on the pumps is demand-dependent
- Anti-jamming function for pumps and valves
- Control of outside air and exhaust air dampers
- Monitoring the outside air and exhaust air filters
- Energy reclamation using closed-loop system (CLS)
- Energy-optimized room/exhaust temperature control with summer increase per DIN 1946
- Supply air temperature control in cooling/energy reclamation/heating sequence
- Summer night ventilation
- Optimized setpoint supply temperature measurement

CONSUMPTION

Ventilation Macros

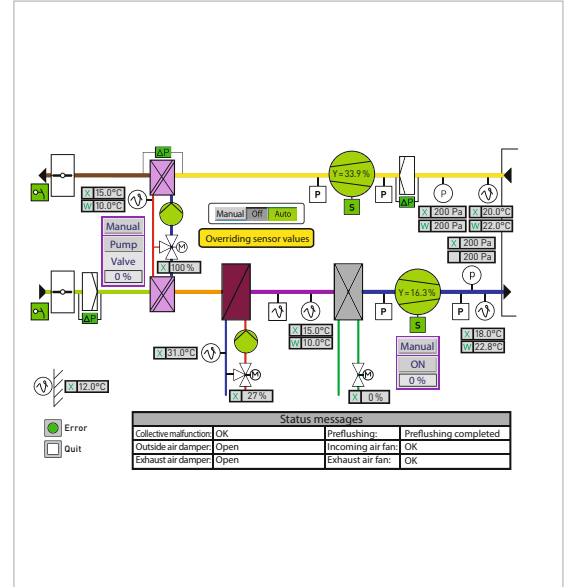
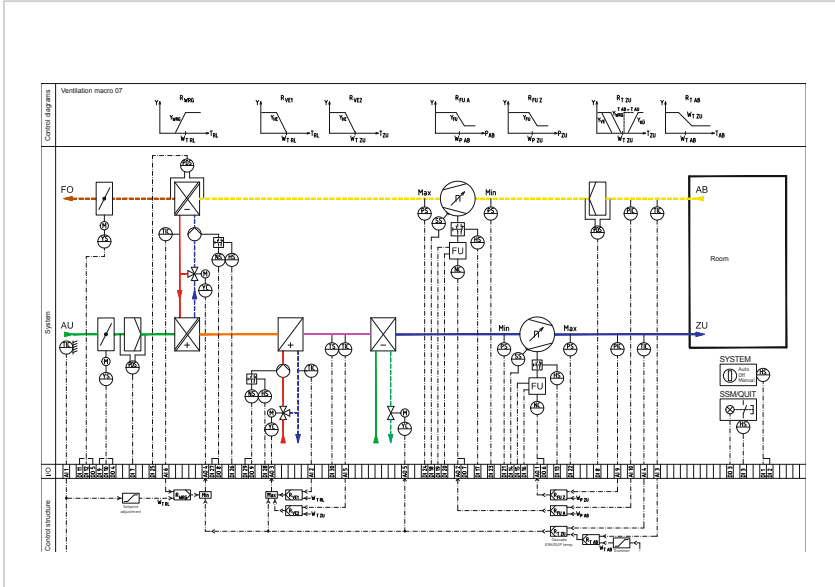

Cascade Control with Rotary Heat Exchanger and Fan with Frequency Converter

The following requirements are met:

- Continuous fan with contactor and operational monitoring
- Pressure control in supply and exhaust air duct
- Upstream and downstream frost protection
- Switching-on the pumps is demand-dependent
- Anti-jamming function for pumps and valves
- Control of outside air and exhaust air dampers
- Monitoring the outside air and exhaust air filters
- Energy recovery using rotary heat exchanger
- Energy-optimized room/exhaust temperature control with summer increase per DIN 1946
- Supply air temperature control in cooling/energy reclamation/heating sequence
- Summer night ventilation
- Optimized setpoint supply temperature measurement

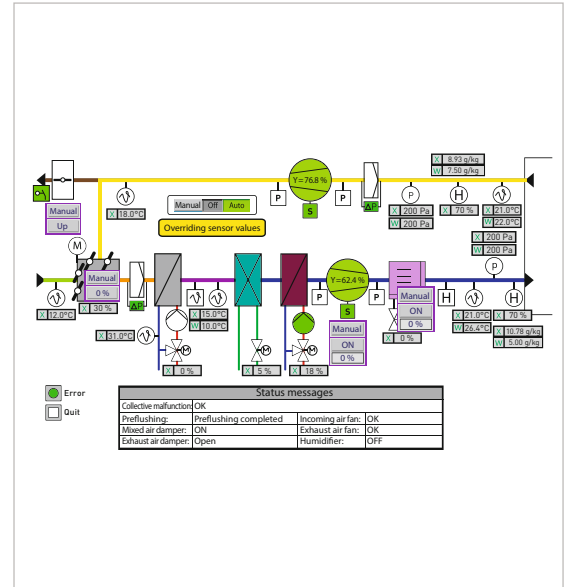
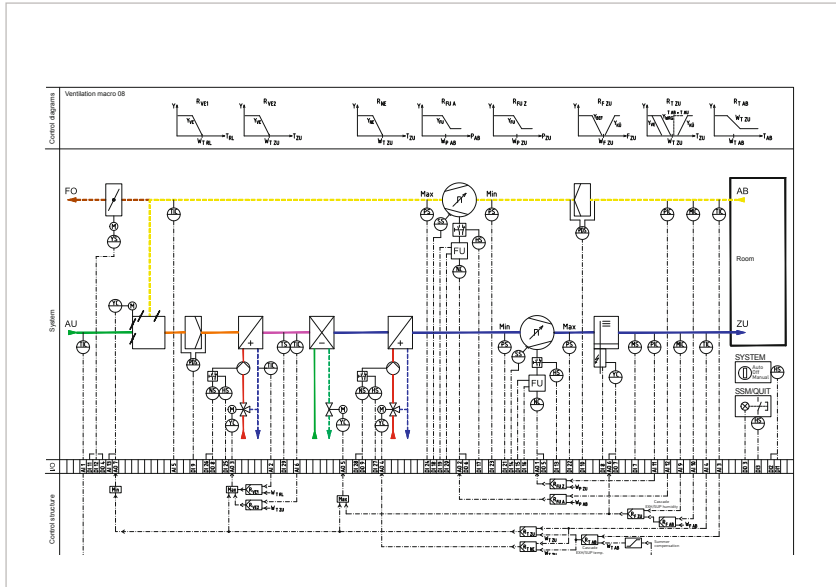

Full Air-Conditioning System with Mixed Air and Fan with Frequency Converter

The following requirements are met:

- Continuous fan with contactor and operational monitoring
- Pressure control in supply and exhaust air duct
- Upstream and downstream frost protection
- Switching-on the pumps is demand-dependent
- Anti-jamming function for pumps and valves
- Control of mixed air and exhaust air dampers
- Monitoring the outside air filter
- Energy-optimized room/exhaust temperature control with summer increase per DIN 1946
- Supply air temperature control in cooling/mixed air/heating sequences
- Room/exhaust air humidity control
- Supply air humidity control with dehumidification/humidification sequences
- Humidification via steam humidifier
- Summer night ventilation
- Optimized setpoint supply temperature measurement



© Rawpixel.com/fotolia.com

UTILIZATION

Single-Room Control

PID Single-Room Controller

This function block permits single-room temperature control while accounting for external factors.

- Separate PID controllers for heating and cooling
- Three different operating modes (comfort, standby and night)
- Adjustable dead zone between heating and cooling
- Setpoint correction via room operating panel
- Window contact analysis to determine switch to frost/heat protection (support mode)
- Dew point detector monitoring

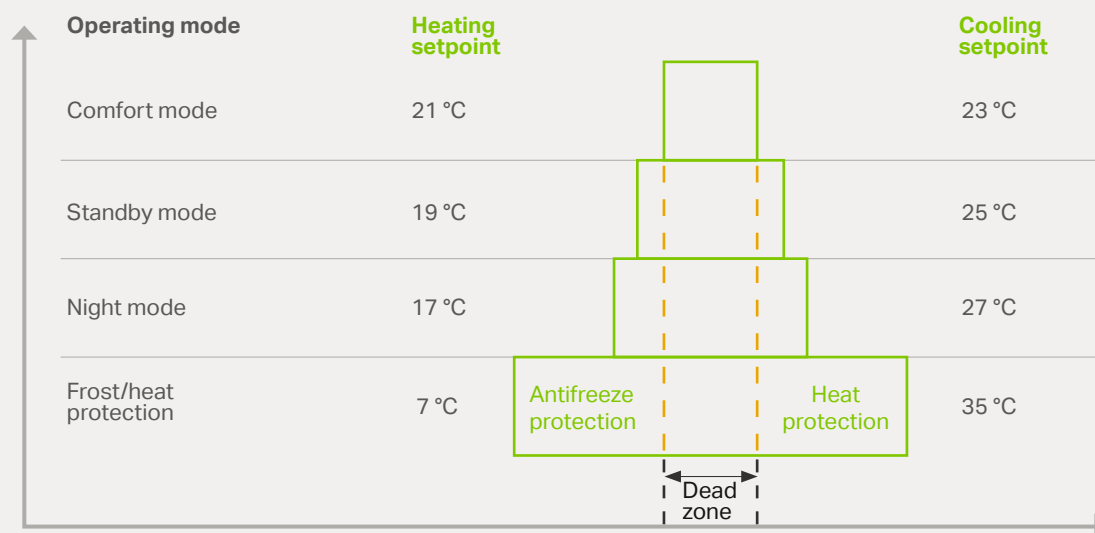

FbPIDSingleRoomController	
rRoomTemperature	rActualTemperature
rSetpointCorrection	rY_Heating
xComfortStandby	rY_Cooling
xNightMode	wY_Heating
xWindowContact	wY_Cooling
xDewpoint	xHeating
rReferenceComfort	xCooling
tpConfigPIDSingleRoomController	rSetpointHeating
	rSetpointCooling
	rComfortHeating
	rComfortCooling
	rStandbyHeating
	rStandbyCooling
	rNightHeating
	rNightCooling
	rSetpointFrost
	rSetpointHeat
	xComfort
	xStandby
	xNight
	xFrost Heal

Operating Mode	Heating Setpoint	Cooling Setpoint
Comfort mode	Basic setpoint: 21 °C	Basic setpoint + Dead zone: 2 K
Standby mode	Basic setpoint, temperature decrease – Standby mode	Basic setpoint + Dead zone + Temperature increase, standby mode
Night mode	Basic setpoint, temperature decrease – Night mode	Basic setpoint + Dead zone + Temperature increase, night mode
Frost/heat protection	Frost protection setpoint: 7 °C	Heat protection setpoint: 35 °C
Dew point alarm	Setting value: 0 (heating off)	Setting value: 0 (cooling off)



WAGO SERVICES

Technical Support

WAGO's technical support staff is ready to assist every customer with advice and guidance: from selecting the right product, through telephone support during commissioning, all the way up to on-site troubleshooting. Customers directly benefit from knowledgeable WAGO experts, allowing them to implement their projects faster.

WAGO provides advice and support with:

- Product selection
- Product commissioning
- Troubleshooting
- Technical questions about WAGO's wide product range

You can reach our support team by:

Phone: +49 571 887 555

Email: support@wago.com

Contact form: www.wago.com > SERVICES

> SUPPORT HOTLINES > Technical Support AUTOMATION

Project Support

WAGO's technical support offers consultation and project planning services to help devise the best possible solutions for your custom building automation and installation projects.

Our experienced team of professionals will gladly help you implement your projects with WAGO products.

Large-scale applications include:

- Production facilities and warehouses
- Office buildings
- Shops and display areas
- Schools
- Hospitals
- Airports

Planning and project engineering:

- Conceptual design
- Network planning
- Application design
- Component selection
- Quote generation

WAGO helps customers with:

- Advice while planning construction projects from experts with years of project experience
- Customizing solutions to ensure the technical and financial success of large projects
- Technical support for implementing building projects



WAGO Seminars

Innovative ideas and advanced technology are the driving forces behind the development and creation of WAGO's market-leading products. Attending WAGO training seminars provides the application insight that enables you to maximize the benefits of WAGO products. The skills and expertise gained in our effective, user-oriented sessions will ultimately save you time and enable you to get the most from our products.

Professional Environment – Effective Learning

- Small groups in which all questions will be addressed.
- Collaborative learning, because education in a group setting is more effective and encourages an exchange of experiences.
- Highly practical – we believe your experiences form the ideal base to build upon with product information that's uniquely tailored to you.

WAGO Building Automation Seminars

- Building automation using WAGO KNX components
- Building automation using WAGO BACnet components
- Building automation using WAGO LON® components
- HVAC applications
- DALI applications
- EnOcean applications
- *flexROOM*®

Custom, On-Site Training

In addition to these open-forum seminars, WAGO also offers sessions that are specifically tailored to your organization and its particular needs. Upon request, we can conduct these seminars at your location.

NOTE

Technical Support

www.wago.com/support

Project Support

Do not hesitate to contact our support team:

www.wago.com/project support

WAGO-Seminars

www.wago.com/seminars



Volker Wiciok/vor-ort-foto.de

APPLICATIONS

Local Tests and Control of Technical Systems

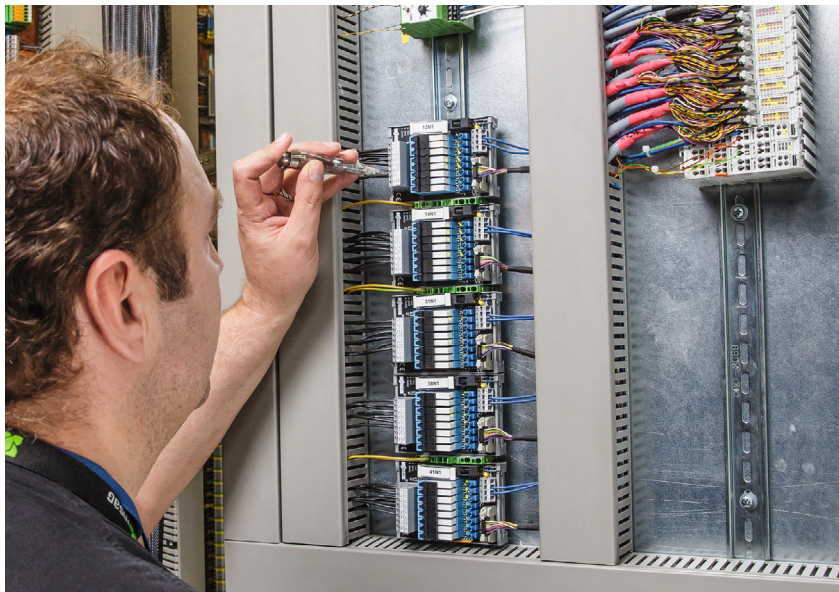

WAGO Kontakttechnik GmbH & Co. KG

Postfach 2880 · 32385 Minden
Hansastraße 27 · 32423 Minden
info@wago.com
www.wago.com

Headquarters	+49 571/ 887 - 0
Sales	+49 571/ 887 - 222
Order Service	+49 571/ 887 - 44 333
Fax	+49 571/ 887 - 844 169

WAGO is a registered trademark of WAGO Verwaltungsgesellschaft mbH.

"Copyright – WAGO Kontakttechnik GmbH & Co. KG – all rights reserved. The content and structure of the WAGO websites, catalogs, videos, and other WAGO media are subject to copyright. Distribution or modification to the contents of these pages and videos is prohibited. Furthermore, the content may neither be copied nor made available to third parties for commercial purposes. Also subject to copyright are the images and videos that were made available to WAGO Kontakttechnik GmbH & Co. KG by third parties."