

Building Automation Overview



Table of Contents

Building Automation with WAGO	4
Building Solutions with WAGO	6
Integrated Building Automation	8
Building Automation – Overview	12
WAGO-I/O-SYSTEM	14
Basic WAGO Software	16
Libraries for Building Automation	18
Modules for Distribution Boxes	20
flexROOM®	22
WINSTA®	24
WAGO Services	26
KNX	28
DALI Multi-Master	30
BACnet	32
Modbus TCP/IP	34
Energy data collection	35
EnOcean Radio Technology	36
Additional Technologies	37
Summary	38



1985
Pluggable Electronic
Modules for DIN-Rail
Terminal Blocks



1995
WAGO-I/O-SYSTEM, IP20



2005
WAGO *SPEEDWAY* 767,
Modular IP67 I/O-SYSTEM

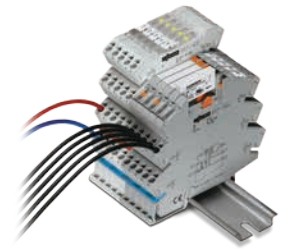

2006
WAGO *JUMPFLEX*® Signal
Conditioners and Pluggable
Relay Modules



1951
The First WAGO
Spring Clamp



1974
WAGO *PUSH WIRE*®
Connectors for Junction
Boxes

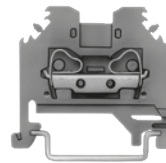

1977
CAGE CLAMP®
DIN-Rail Terminal Blocks

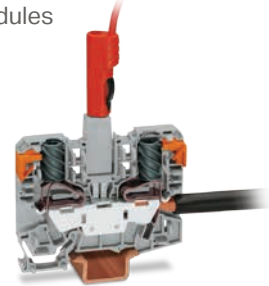

1998
POWER CAGE CLAMP

AT HOME – WORLDWIDE

More than 50 Years of Innovation

Building Automation with WAGO – The Winning Formula for Architects, Planners and Developers

Since its founding in 1951, WAGO has pioneered innovative electrical interconnect and electronic interface systems. That same year, the idea for a screwless termination system was born and the first spring pressure terminal blocks were introduced.

WAGO's *ELECTRICAL INTERCONNECTIONS* division has undergone rapid development over the years, paving the way for more industry-leading

innovations. In 1995, WAGO reached another milestone by launching the WAGO-I/O-SYSTEM, the world's first fieldbus-independent and finely modular I/O system.

The introduction of industrial fieldbus systems has significantly impacted automation. Modern, decentralized topologies with distributed "intelligence" have replaced traditional, centralized automation structures.



WAGO Global Headquarters – Minden, Germany



WAGO Sondershausen, Germany



WAGO Switzerland



2008
TO-PASS® – Scalable
Telecontrol Technology



2011
PERSPECTO®



2012
flexROOM®



2014
WAGO-I/O-SYSTEM 750 XTR

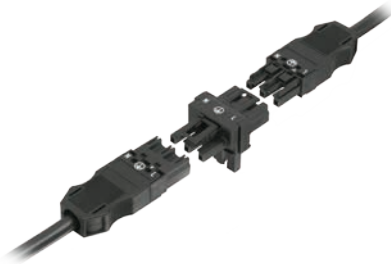

2001
WINSTA® Pluggable
Connection System



2003
TOPJOB® S DIN-Rail
Terminal Blocks



2004
WAGO 222 Series
CLASSIC Splicing
Connectors for All
Conductor Types



2010
WAGO COMPACT
PUSH WIRE®
Connectors for
Junction Boxes



2014
WAGO 221 Series
COMPACT Splicing
Connectors for All
Conductor Types

Now, WAGO is meeting virtually all of the industry's needs as both the leader in Spring Pressure Connection Technology and a pioneer in automation technology. For more than a decade, WAGO has offered a wide range of advanced building automation components based on the WAGO-I/O-SYSTEM 750.

The I/O system's modular design enables solutions for pressing projects to be easily, and efficiently, implemented. A wide range of controllers with open fieldbus protocols (e.g., BACnet, KNX or MODBUS) in combination with standard inputs/outputs or subsystems (e.g., DALI, EnOcean or LonWorks®) covers the entire building automation market.



WAGO Brazil



WAGO China



WAGO USA

BUILDING SOLUTIONS FROM WAGO

for Specific Markets



© Paulista/Fotolia.com

Office and Administrative Buildings

Investors are increasingly placing a great amount of importance on flexible spaces supported by an appropriate infrastructure. WAGO's room automation systems can be commissioned quickly and flexibly adapted to address this need.

Meeting the European Union's most stringent energy guidelines, class A (per DIN EN 15232), can be easily and reliably achieved using WAGO products.



iStock.com/Jkitan

Production Facilities and Warehouses

Safe and efficient energy management in production facilities and warehouses is essential to reduce operating costs. Lighting significantly contributes to overall operating costs.

Using WAGO's solutions, energy costs can be reduced by up to 30 %.

Retail Centers

Building operation is becoming more and more expensive – a key reason why operators are searching for new building automation solutions. Intelligent buildings provide a secure and comfortable environment, while keeping costs under tight control. WAGO's building automation systems can readily help operators meet specific energy costs to improve the bottom line.

© photocreao/Fotolia.com



Public Infrastructure Buildings

Visitor safety, comfort and convenience are of primary importance in operating airports, convention centers and railway stations. WAGO's integrated building automation solutions meet the high efficiency and safety standards for public infrastructure buildings that serve thousands daily.

© Carsten Kyka/Fotolia.com



INTEGRATED BUILDING AUTOMATION –

shutterstock.com/Michael Warwick

iStock.com/Oliver Hoffmann



shutterstock.com/photosphobos



Lighting

The ideal lighting control system not only creates an atmosphere that promotes a sense of well-being, but also economizes room and building lighting. WAGO's lighting control solutions skillfully set up lighting scenes – from simple switching and dimming up to tailored and daylight-dependent lighting controls. Both demanding color temperature control for enhanced well-being and productivity, as well as the impressive and artistic lighting of buildings, can be easily implemented using WAGO products.



HVAC

Heating, ventilation and air conditioning (HVAC) systems represent one of a building's major costs. Automatically regulating HVAC systems minimizes energy costs and improves the climate in a building. Planning and executing HVAC systems requires extensive knowledge from every building automation professional, starting with the creation of demanding control programs on through to visualizing energy flows. Extensive libraries with ready-made system macros generally make programming unnecessary. The use of these system macros contributes to standardization, significantly reducing costs.

BETTER ENERGY EFFICIENCY







Room Automation

Planning, implementation and building operation must demonstrate maximum efficiency and a high degree of adaptability. Modern building technology maximizes flexibility by enabling rooms to be individually planned, managed and even repurposed at any time – without any programming. WAGO's modern room automation solutions perform many tasks in a building. They optimize room temperature, automatically adjust shades based on the sun's position throughout the day, regulate light intensity and switch lights off when not needed.



Energy Management

Energy efficiency hinges on the savvy planning of a building's technical infrastructure. Constructing or retrofitting buildings is an operational challenge in terms of energy savings. Investors must see a high level of energy efficiency being incorporated into their buildings. Compliant with the European Union's energy efficiency class A, WAGO's energy management solutions can help reassure investors that the building's operational life-cycle costs will be minimal.

WAGO BUILDING AUTOMATION

Universal, Compact, Economical – WAGO-I/O-SYSTEM

Management Level

At the management level, building automation is an integral part of both cost and facility management; it's also a key component in overall building control. Open protocols link higher-level functions to building automation. To make the most of these protocols, WAGO offers software tools for commissioning and diagnostics to optimally support both system engineering and monitoring. Access to the Web visualization of each individual control unit is also performed at this management level.

Automation Level

ETHERNET has long established itself as the dominant medium at the automation level. As such, WAGO's control units can be easily and efficiently interlinked using open, standardized bus protocols for building automation (e.g., BACnet IP, KNX IP or Modbus/TCP). Standardized protocols provide interoperable and future-ready interfaces between individual building technologies and levels.

Field Level

Depending on the application, building automation systems can vary greatly from one building level to the next, requiring different transmission media (wired or wireless) and interfaces. Thus, flexible and easy-to-install media are required on the field level (room level). This is why WAGO offers a wide variety of solutions ranging from the direct control of standard sensors and actuators via interfaces to two-wire subsystems (e.g., DALI, BACnet MS/TP, KNX TP1 or LonWorks®), on through to radio-based solutions such as EnOcean or Bluetooth®.

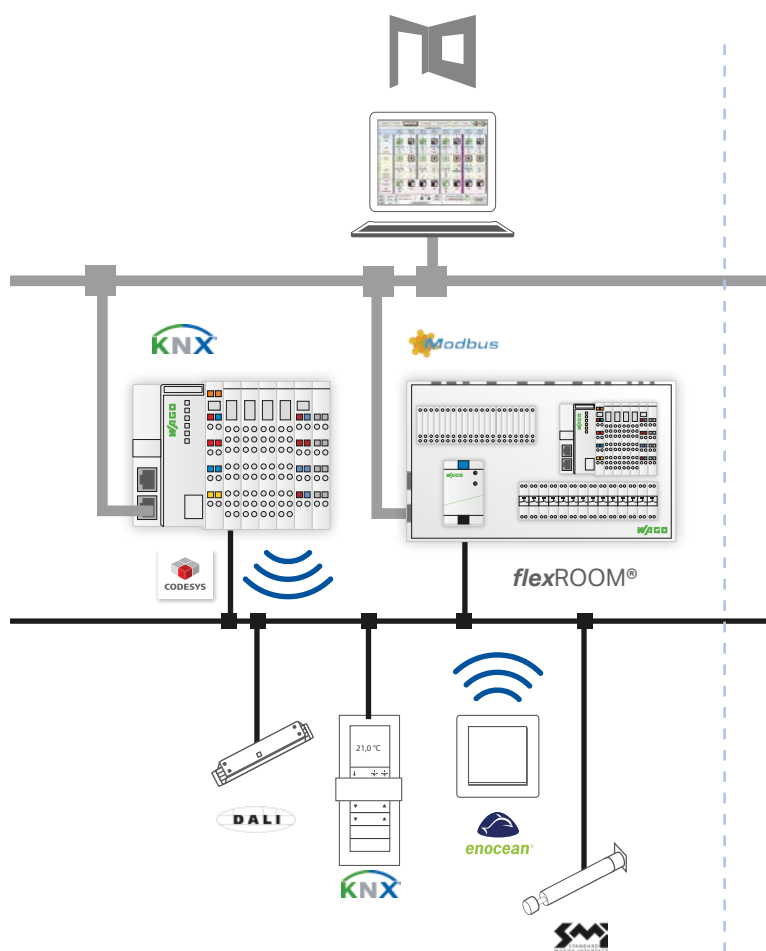

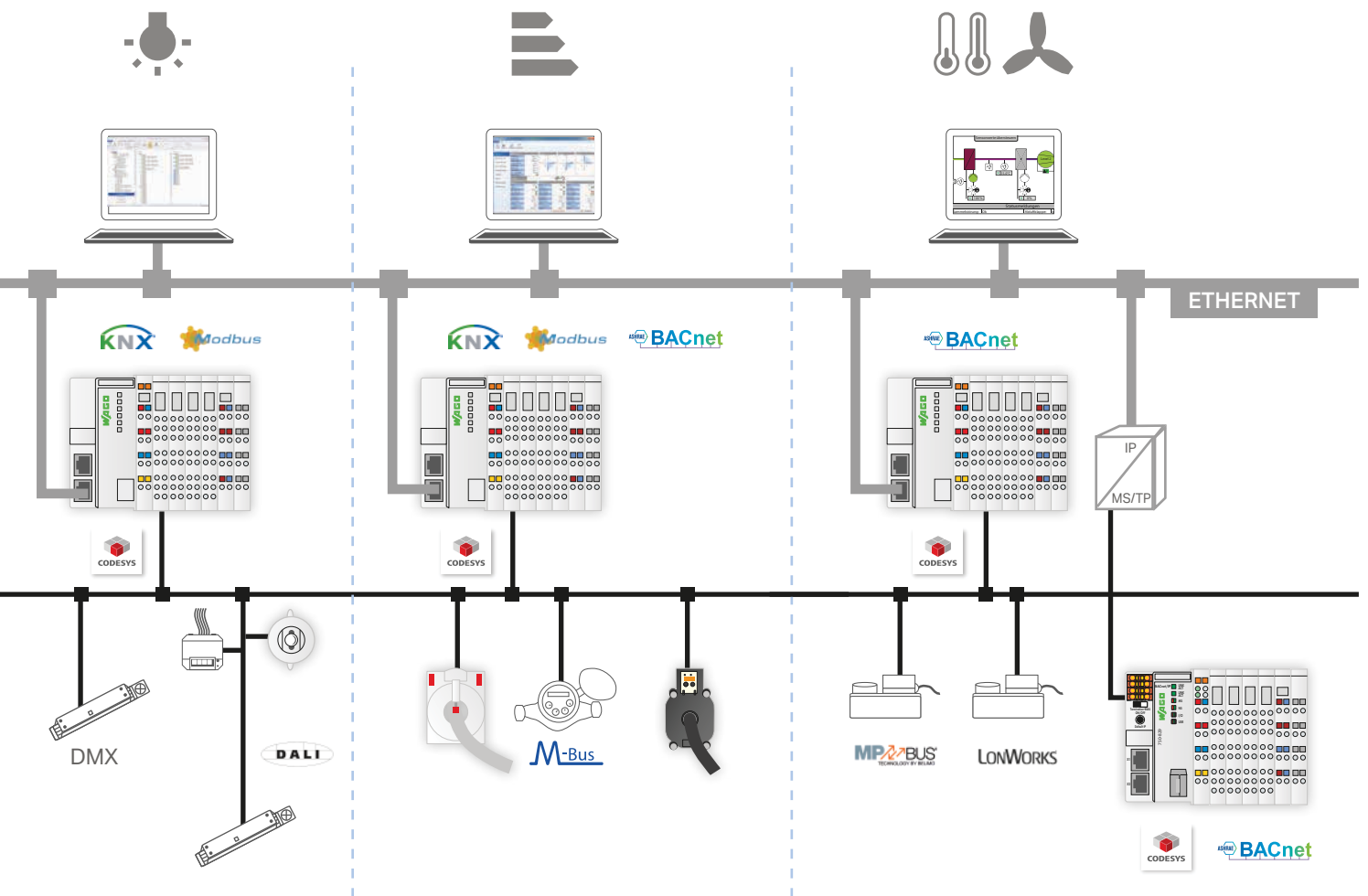



© panthermedia.net/scanrail

WAGO-I/O-SYSTEM

Fieldbus Controllers and I/O Modules

WAGO's comprehensive range of fieldbus controllers supports established protocol standards. Configuration, programming and visualization are easily performed using the IEC 61131-3-compliant WAGO-I/O-PRO software package.

BACnet Controllers

For BACnet communication, WAGO offers two different controllers equipped with BACnet/IP (ETHERNET) or BACnet MS/TP (RS-485) interfaces. Both high-performance controllers support the BACnet Building Controller (B-BC) profile and are freely programmable. The controllers can be easily commissioned with WAGO's user-friendly BACnet Configurator.

KNX IP Controller

The KNX IP fieldbus controller is freely programmable and communicates via standard 10/100 Mbit ETHERNET network. Commissioning the KNX interface is performed using the ETS Network Management Tool. A product database from WAGO is available for commissioning the controller.

ETHERNET Controllers

WAGO provides a wide range of ETHERNET controllers in different performance classes and with various interface combinations. The ETHERNET fieldbus controllers support Modbus TCP. A wide variety of standard ETHERNET protocols is also supported for easy integration into IT environments (e.g., HTTP, BootP, DHCP, DNS, SNTP, SNMP, FTP).



 BACnet



 KNX



 Modbus



Analog Input Modules

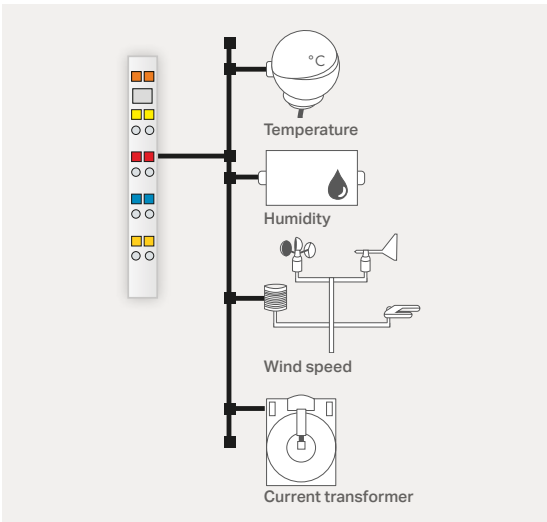

Analog Output Modules

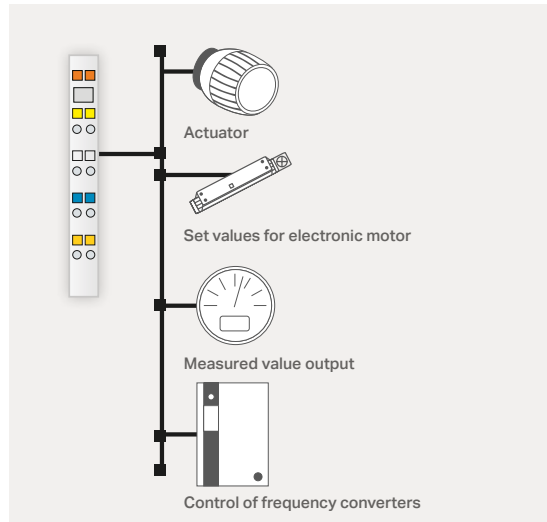

Digital Input Modules

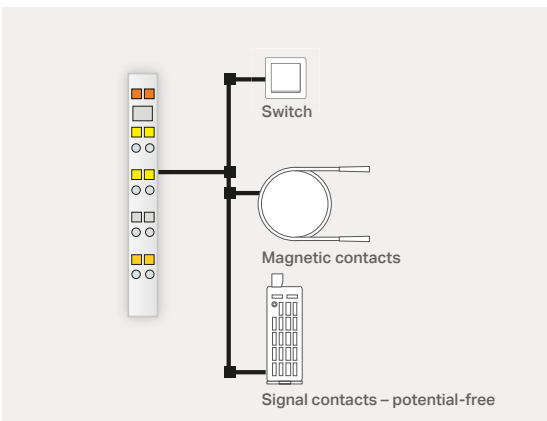

Digital Output Modules

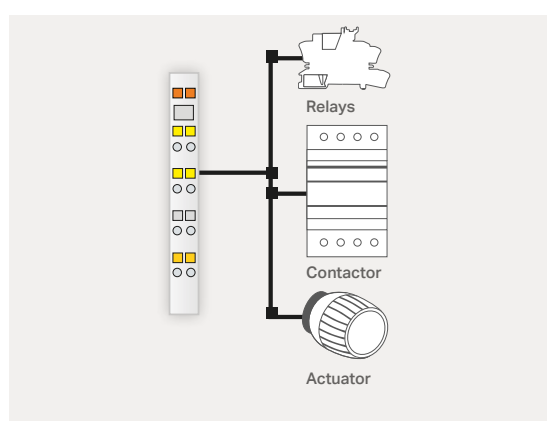

Communication Modules

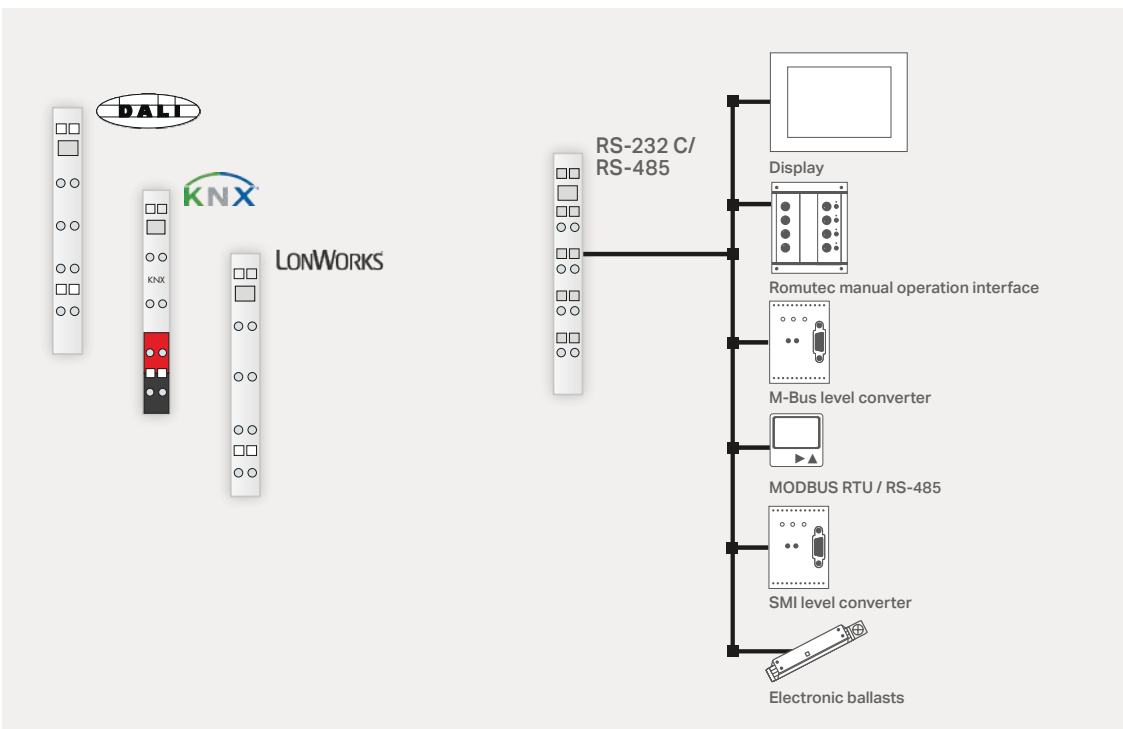

BASIC WAGO SOFTWARE

WAGO-I/O-CHECK

WAGO-I/O-CHECK is an easy-to-use Windows® application for checking inputs and outputs, as well as displaying a WAGO-I/O-SYSTEM 750 node. The node does not have to be connected to a fieldbus system.

In addition to checking the actuators/sensors connected on the field-side and module-specific configurations, the application can also document node configuration.

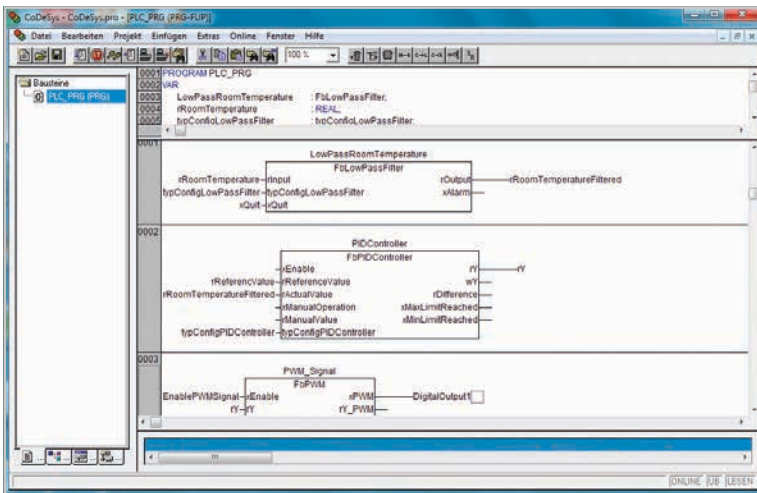

WAGO-I/O-PRO

WAGO-I/O-PRO is a basic tool for creating control programs. The software contains six major, IEC 61131-3 graphic/text-based programming languages (FBD, LD, IL, ST, CFC and SFC), providing users with flexibility.

Using WAGO-I/O-PRO, programs can be individually created. In addition, pre-designed function blocks can also be accessed from software libraries. Graphically structured programs, such as those created with the Function Block Diagram (FBD) programming language, are very easy to create.

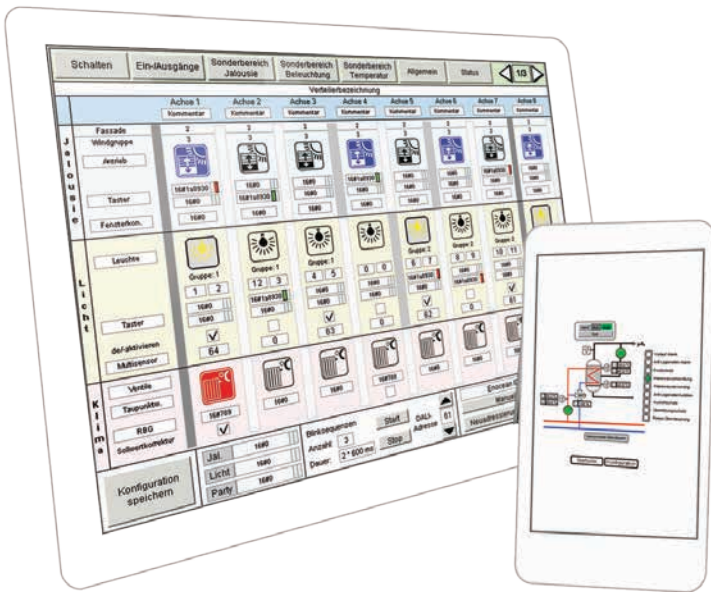

Web Visualization

Project-specific visualizations are generated in a graphic editor in the WAGO I/O-PRO software. Ready-made macros with a graphical configuration interface are available for certain functions or function blocks, which can be easily integrated into a project.

Visualization is performed on a Web server, which is locally contained in the ETHERNET controller. This allows the visualization to be displayed in a Web browser on any computer connected to the Internet (e.g., for remote maintenance). The Web visualization can also be accessed on a tablet or smartphone using an app.

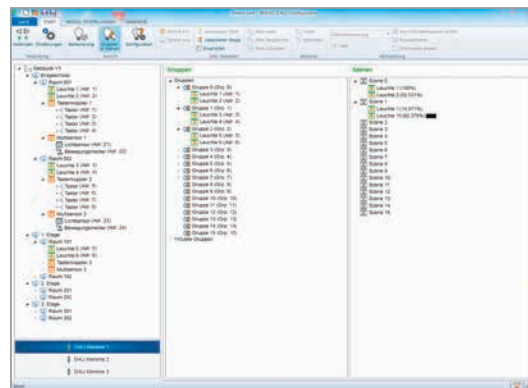
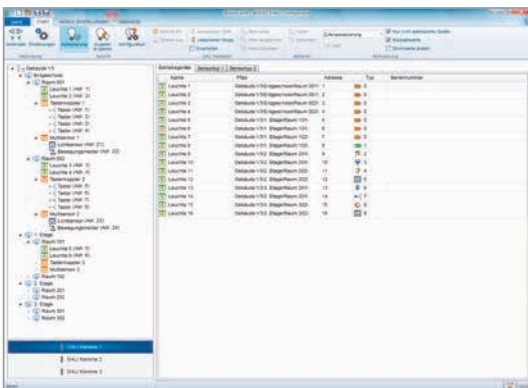

Specific Software Tools

In addition to the previously described general software tools, WAGO also offers a selection of other tools specifically designed for a certain technology, application or product. WAGO therefore offers both DALI and BACnet Configurators, allowing devices connected to a specific network to be easily and efficiently addressed and parameterized. The individual tools and their functions are described on their respective product or technology pages.



iStock.com/Oliver Hoffmann

iStock.com/Marchcattle

LIBRARIES

Building Automation

To simplify programming, WAGO has a multitude of pre-configured functions available for free: from simple room applications (such as lighting, dimming and anti-glare control) to HVAC modules, system macros and communication applications. The latter offers interfaces to LON®, DALI, EnOcean radio technology and MP-Bus, while enabling emails and SMS messages to be sent. The libraries can be directly used for efficient and error-free customer applications.

Libraries Exist for the Following:

- Room/air intake temperature cascade control
- Single-room control
- Lighting
- Lighting scenes
- Lighting control
- Sun protection

HVAC:

- Error message monitoring
- Frost protection monitoring
- Heat recovery
- Room/air intake temperature cascade control
- Heating circuit control
- Boiler sequence control

Communication:

- EnOcean radio technology
- DALI
- DMX
- M-Bus
- SMI
- MP-Bus
- KNX/EIB
- SMS/Email
- ...

All current libraries and application notes can be downloaded at www.wago.com.

Application Notes

WAGO has an extensive library of detailed application notes for complex tasks, including: measurement, control, regulation technology (system macros, e.g., cascaded control systems with recirculated air) and other building automation applications. In addition, the application programs are ready to use. And to simplify project development, the application notes can be consulted, or used directly as templates for custom programming. The programs are executable and have the WAGO-I/O-PRO software environment. This interface can also be used via Web browser for controllers equipped with a Web server. Other application examples: M-Bus meter reading, connection to bidirectional EnOcean gateways, energy data acquisition via 3-Phase Power Measurement Module, iPhone connection and much more.

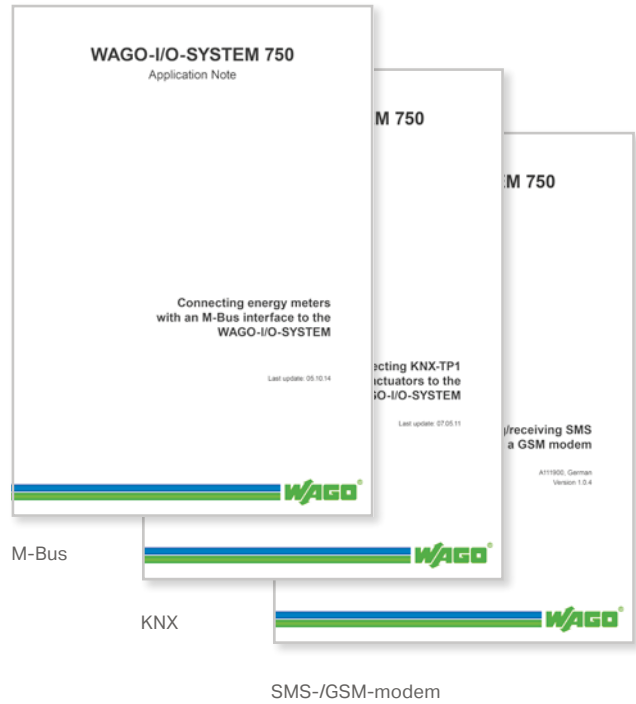

Macros for Ventilation, Boiler, Heating Circuit and Duty Cycle Monitoring (Hot Water), Including Ready-to-Use Configuration Screens in Web Visualization

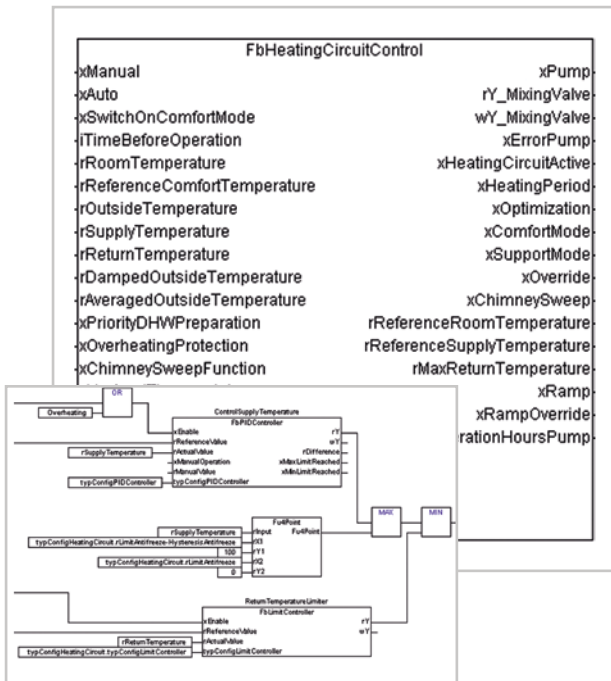

"Heating circuit" function block

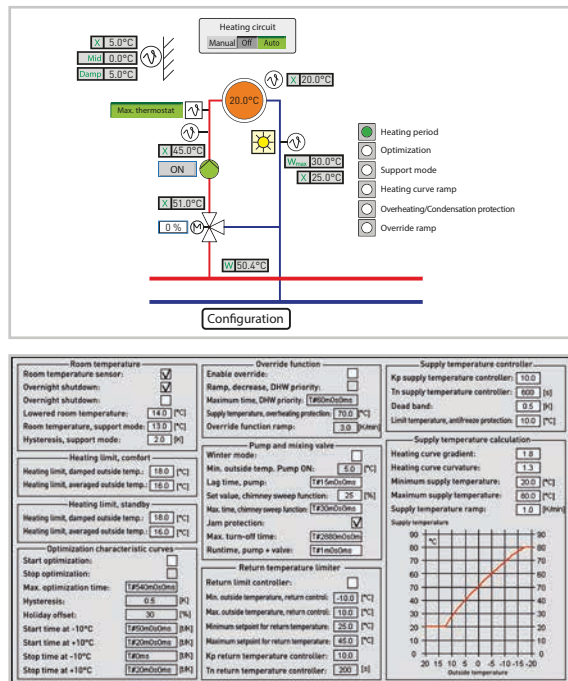

Configuration screens in a Web Visualization



3-Phase Power Measurement Modules



Rogowski Coils RT 500



EPSITRON® Power Supplies



Plug-In Current Transformers with picoMAX® Pluggable Connectors



Relay Modules



RJ-45 Connectors



Industrial Switches

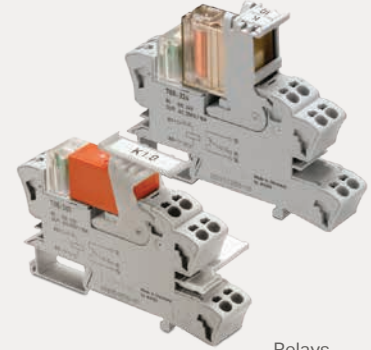

Relays

MODULES FOR DISTRIBUTION BOXES

The products and solutions outlined in this brochure form a solid foundation for building automation. However, additional peripheral systems, control modules and components are required for complete automation solutions. WAGO not only provides a wide range of products, but can also furnish tailor-made solutions consisting of fully equipped system distribution boxes. Users not only benefit from shortened assembly times and error-free installation, but also from easier commissioning.

Key Components at a Glance:

- **Power Supplies**
The *EPSITRON*® Series provides 24 V to power WAGO controllers and IPCs.
- **Network Infrastructure Components**
From a simple switch to configurable communication capabilities with a fiber optic connection
- **Customizable ETHERNET**
User-configurable RJ-45 ETHERNET connectors
- **Transfer Modules**
For RJ-45 patch cables and universal connections, such as a 9-pole Sub-D RS-232 connection
- **Relays**
Control consumers, such as lights, shutter drives and much more.

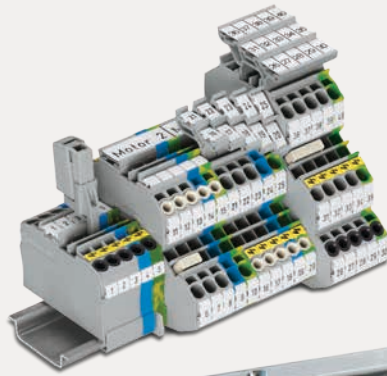

TOPJOB® S DIN-Rail Terminal Blocks

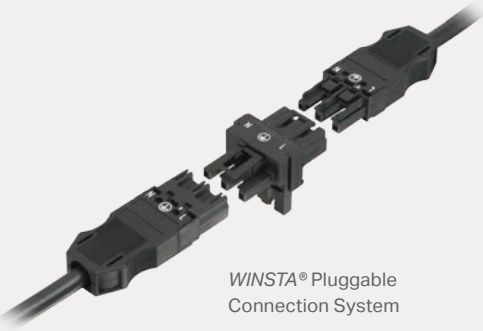

WINSTA® Pluggable Connection System

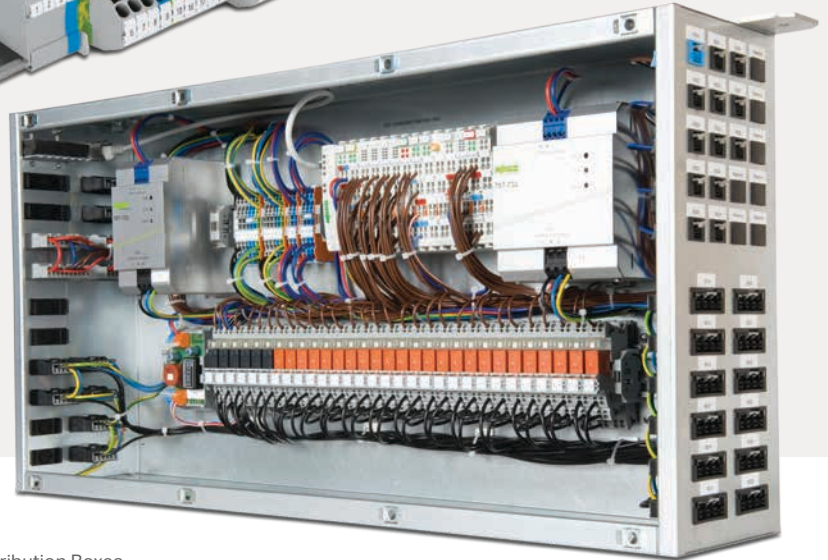

Distribution Boxes

- **WINSTA® Pluggable Connectors**

Innovative connectors from the WAGO WINSTA® system for preassembled components that provide fast and safe on-site installation; accommodate conductor cross-sections up to 4 mm² (12 AWG) and nominal currents up to 25 A.

- **Screwless DIN-Rail Terminal Blocks**

WAGO TOPJOB® S is a range of screwless DIN-rail terminal blocks for building installations with conductor cross-sections of 1.5 mm² to 16 mm² (16–6 AWG).

- **Current Measurement**

Coupled with Electronic Interface devices and the WAGO-I/O-SYSTEM 750, WAGO offers a comprehensive range of perfectly tuned energy efficiency solutions.

- **WAGO-I/O-SYSTEM**

Advantages of WAGO's successful fieldbus system: solution with scalable performance, high integration density and an unbeatable price/performance ratio.

- **Custom, Ready-Made Solutions**

WAGO product specialists have the experience and efficient solutions to assist you from initial specs to final installation.



iStock.com/zhudifeng

flexROOM[®] **A Flexible Room Concept**

Our Concept

Planning, commissioning and building operation must demonstrate maximum efficiency and a high degree of adaptability. Pre-configured programs and pre-defined hardware significantly streamline planning and commissioning. The more applications created within a project, the greater the benefit. Flexible building operation (e.g., conversions and room remodeling) via special maintenance levels eliminates external service costs.

Assemble, commission and configure according to project specifications – WAGO *flexROOM*[®] combines these strengths into a standard module. The contained control unit and application software are precisely tailored to room requirements.

Parameterization

For each room, parameters can be individually stored for lighting, shading and room control. All parameters are cyclically saved either directly in the distribution box or in a separate computer, and are available via network connection. A higher-level management station accesses the distribution box parameters via open Modbus TCP/IP protocol. This ensures that all modifications can be implemented on site or via the management station. Systems with BACnet or KNX IP can also be connected via Modbus TCP/IP.

Configure Instead of Program!

Each WAGO *flexROOM*[®] Distribution Box has a Web interface. Both the commissioning technician and end-user can configure the controls for each room via Web browser, regardless of location and distribution box. Complete wall relocations, room assignments, lighting and shading groups can be changed from the parameter interface – no additional software is required.

flexROOM® Advantages

The distribution boxes are delivered ready to operate and can be installed directly in a suspended ceiling or a sub-floor. Room axis configuration is performed directly in the distribution box via standard Web browser. No expert knowledge is required to configure rooms or convert them later. Several flexROOM® Distribution Boxes can be wired into a building automation network via ETHERNET, allowing the automation of a building area, floor or the entire office section. A standard Web browser also establishes communication between the distribution boxes. If electrical distribution boxes are present, then flexROOM® components can also be installed in them or retrofitted during facility renovation. flexROOM® reduces space conversion costs because it provides transparent, easy-to-project expenses.

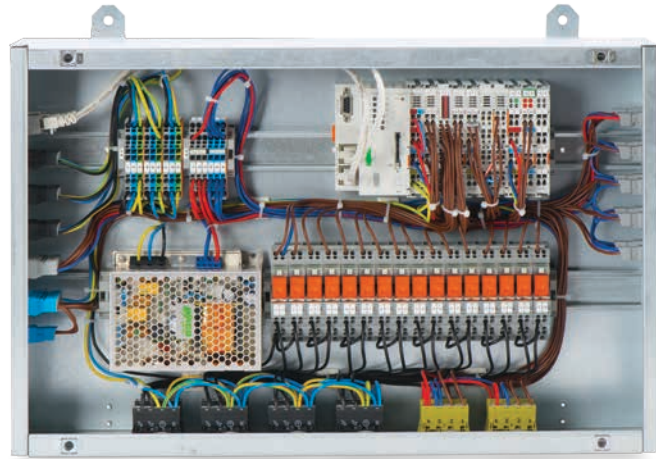

The floor plan shows a grid of rooms numbered 1 to 10. Room 7 is highlighted in yellow. Below the floor plan is a screenshot of a web-based control interface for the flexROOM system. The interface is divided into several sections:

- DATEI:** Includes icons for 'Jalousie' (blinds), 'Licht' (light), and 'HLK' (HVAC).
- RAUMLISTE:** Lists 'Zentral Licht', 'Zentral Jalousie', and 'Zentral Party' with numerical values.
- SCHWELFBEREICH:** A dropdown menu set to '24704E'.
- MANUELL:** A checkbox.
- ACHSEN:** A grid of 8 columns (Achse 1 to Achse 8) and 3 rows (Licht, Jalousie, HLK). Each cell contains a control element (light bulb, blinds icon, or thermometer) and a 'Stufen' (steps) control.

WINSTA®

A Complete Series Perfects the System

WINSTA® MINI
WINSTA® MINI special



WINSTA® MIDI
WINSTA® MIDI special



WINSTA® MIDI Linect®

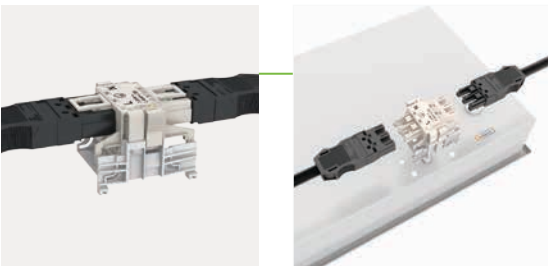

WINSTA® MAXI





WINSTA® RD



WINSTA® KNX

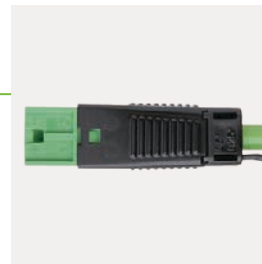

WINSTA® IDC





WAGO SERVICES

Technical Support

WAGO's technical support staff is ready to assist all customers with advice and guidance: from selecting the right product, through telephone support during commissioning, all the way up to on-site troubleshooting. Customers directly benefit from knowledgeable WAGO experts who help customers implement their projects faster.

WAGO Provides Advice and Support with:

- Product selection
- Product commissioning
- Troubleshooting
- Technical advice on WAGO's wide product range

Contact Technical Support:

- by phone on +49 571 887 555
- by email at support@wago.com
- via the contact form at www.wago.com > Service > Support-Hotlines > Technical Support
AUTOMATION

Project Support

WAGO offers consulting and project planning services to help devise the best possible solutions for your custom building automation and installation projects. Our experienced team of professionals will gladly help you implement your projects with WAGO products.

Large-Scale Applications Include:

- Production facilities and warehouses
- Office buildings
- Shops and display areas
- Schools
- Hospitals
- Airports

Planning and Project Design:

- Conceptual design
- Network planning
- Application design
- Component selection
- Quote generation

WAGO Helps Customers with:

- Advice while planning construction projects from experts with years of project experience.
- Customizing solutions to ensure the technical and financial success of large projects.
- Technical support for implementing building projects.



WAGO Seminars

Innovative ideas and advanced technology are the driving forces behind the development and creation of WAGO's market-leading products. Attending WAGO training seminars provides the application insight that enables you to maximize the benefits of WAGO products. The skills and expertise gained in our effective, user-oriented sessions will ultimately save you time and enable you to get the most from our products.

Professional Environment – Effective Learning

- Small groups in which all questions will be addressed.
- Collaborative learning, because education in a group setting is more effective and encourages an exchange of experiences.
- Highly practical – we believe your experiences form the ideal base to build upon with product information that's uniquely tailored to you.

WAGO Building Automation Seminars

- Building Automation with WAGO KNX components
- Building Automation with WAGO BACnet components
- Building Automation with WAGO-LON® components
- Heating, ventilation and air conditioning applications
- DALI applications
- EnOcean applications
- **flexROOM®**

Custom, On-Site Training

In addition to these open-forum seminars, WAGO also offers sessions that are specifically tailored to your organization and its particular needs. Upon request, we can conduct these seminars at your location.

NOTE

Technical Support

www.wago.com/support

Project Support

Find our contact partners at:

www.wago.com/projektunterstuetzung

WAGO Seminars

www.wago.com/seminars

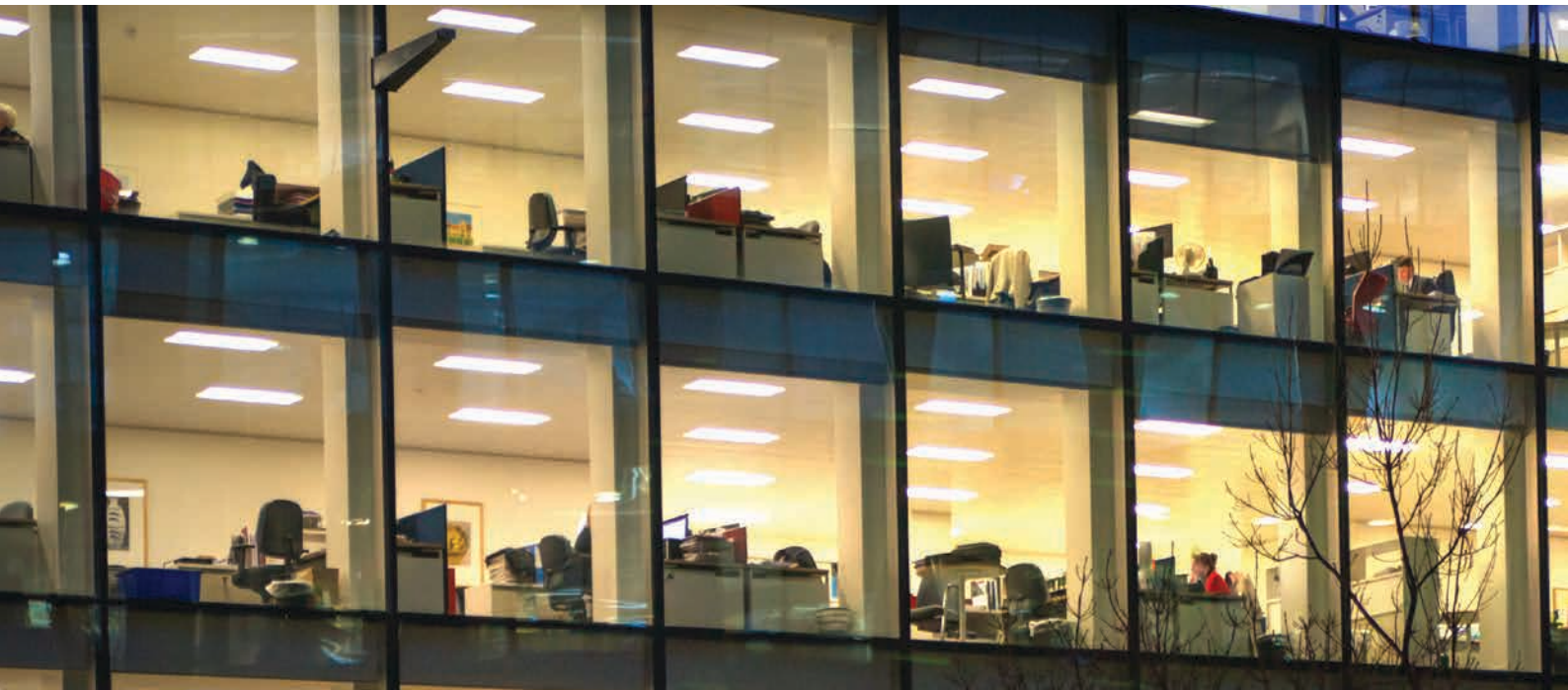

© IRStone/Fotolia.com

KNX

Maximum Flexibility and Powerful Performance

KNX is a uniform, manufacturer-independent communication protocol for intelligently networking various building automation functions. KNX is used to plan and implement energy-efficient solutions, while incorporating greater functionality and convenience into buildings.

Global communication standards paired with maximum data speeds make ETHERNET an indispensable building automation technology. With its **KNX IP Controller**, WAGO offers a product that links the KNX world with ETHERNET, and makes it freely programmable. Using this controller, you can link, control, regulate and monitor all types of KNX devices from a variety of sectors. When paired with the WAGO-I/O-SYSTEM 750 I/O modules, other sensors, actuators and sub-buses (e.g., DALI and EnOcean) can be easily integrated into the controller.

The **KNX TP1 Module** connects KNX TP1 networks to the WAGO-I/O-SYSTEM and is compatible with all building-related WAGO controllers (e.g., BACnet).

Combining a **KNX IP Controller** with a **KNX TP1 Module** creates a router that automatically connects the KNX two-wire bus system to ETHERNET. This provides a tremendous amount of freedom to conveniently operate buildings or systems via the Internet – wherever you are.

WAGO ETS Plug-In

The ETS standard programming tool assigns group addresses and commissions WAGO KNX products. WAGO's custom-developed plug-in supports users in configuring the KNX interface.

Additional Benefits

WAGO's innovative KNX components are seamlessly integrated into the WAGO-I/O-SYSTEM. This provides a wide range of input, output and specialty modules for sub-bus systems (e.g., DALI), as well as controllers for higher-level networks (e.g., BACnet). Cost-effective control units replace several individual KNX components as room and zone controllers. The KNX standard provides communication with thousands of devices from other manufacturers.



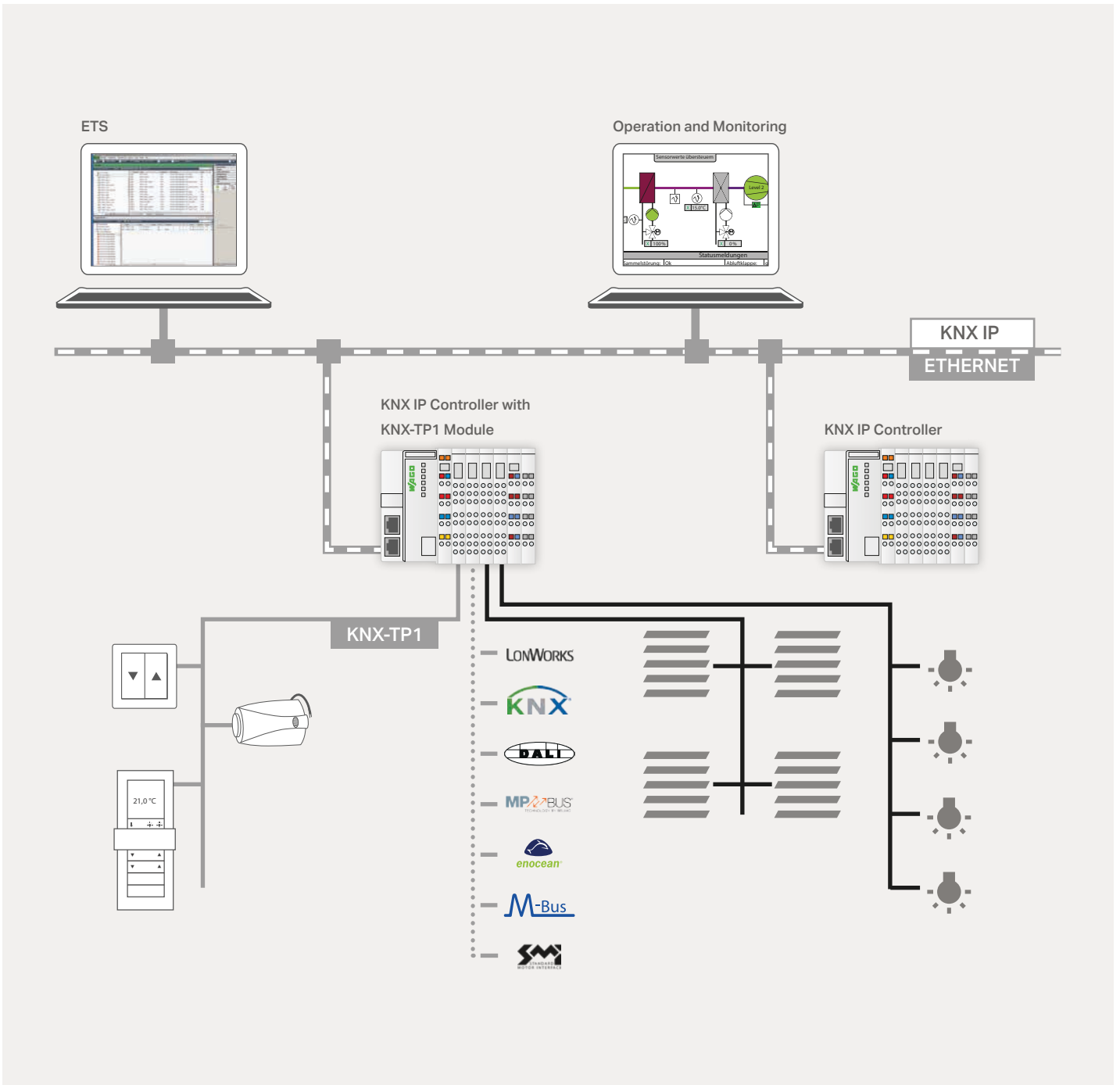



© lightpixel/Fotolia.com

DALI

Flexible Solutions and Simple Commissioning

DALI stands for “Digital Addressable Lighting Interface” and is a protocol that adheres to the IEC Standard 62386. The DALI standard, a protocol common to all manufacturers, substitutes for the 1–10V dimmer interface and ensures the interoperability of DALI devices (e.g., electronic ballasts in lighting applications). A DALI master can control a line with up to 64 devices. In addition, sensors (e.g., brightness measurement and presence detection) can be integrated into a DALI network.



A DALI system allows individual lights or lighting groups to be controlled. No parallel wiring of the control groups is necessary. Assigning individual lights to operating elements and the grouping of lights can also be done after installation and is possible at any time without re-wiring.

The **DALI Multi-Master Module** is a comprehensive and highly flexible IEC 62386-compliant interface for the modular WAGO-I/O-SYSTEM 750. Combined with controllers and I/O modules from the WAGO-I/O-SYSTEM, even complex DALI lighting applications can be realized. In addition, the module can function as an interface to numerous fieldbus and sub-bus systems. There is no need to install an additional sensor bus, since sensors can be easily integrated into a DALI network.

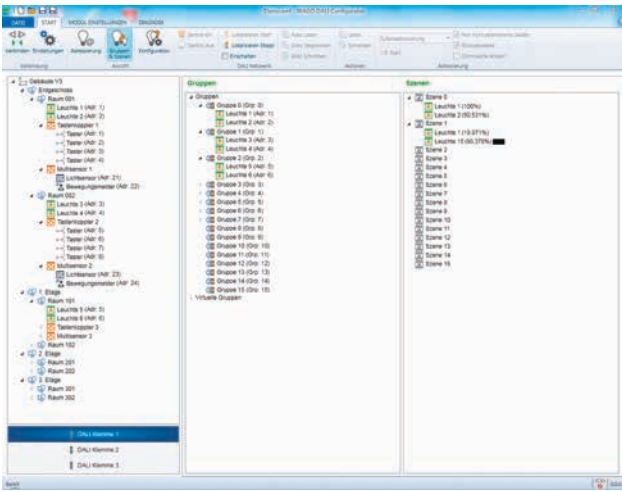

DALI network devices are configured and commissioned using WAGO's DALI Configurator. This tool includes comprehensive functions that simplify and streamline both the installation and maintenance of a DALI network. These functions include: addressing and configuring all DALI network devices, group and scene formation, as well as comprehensive diagnostics.

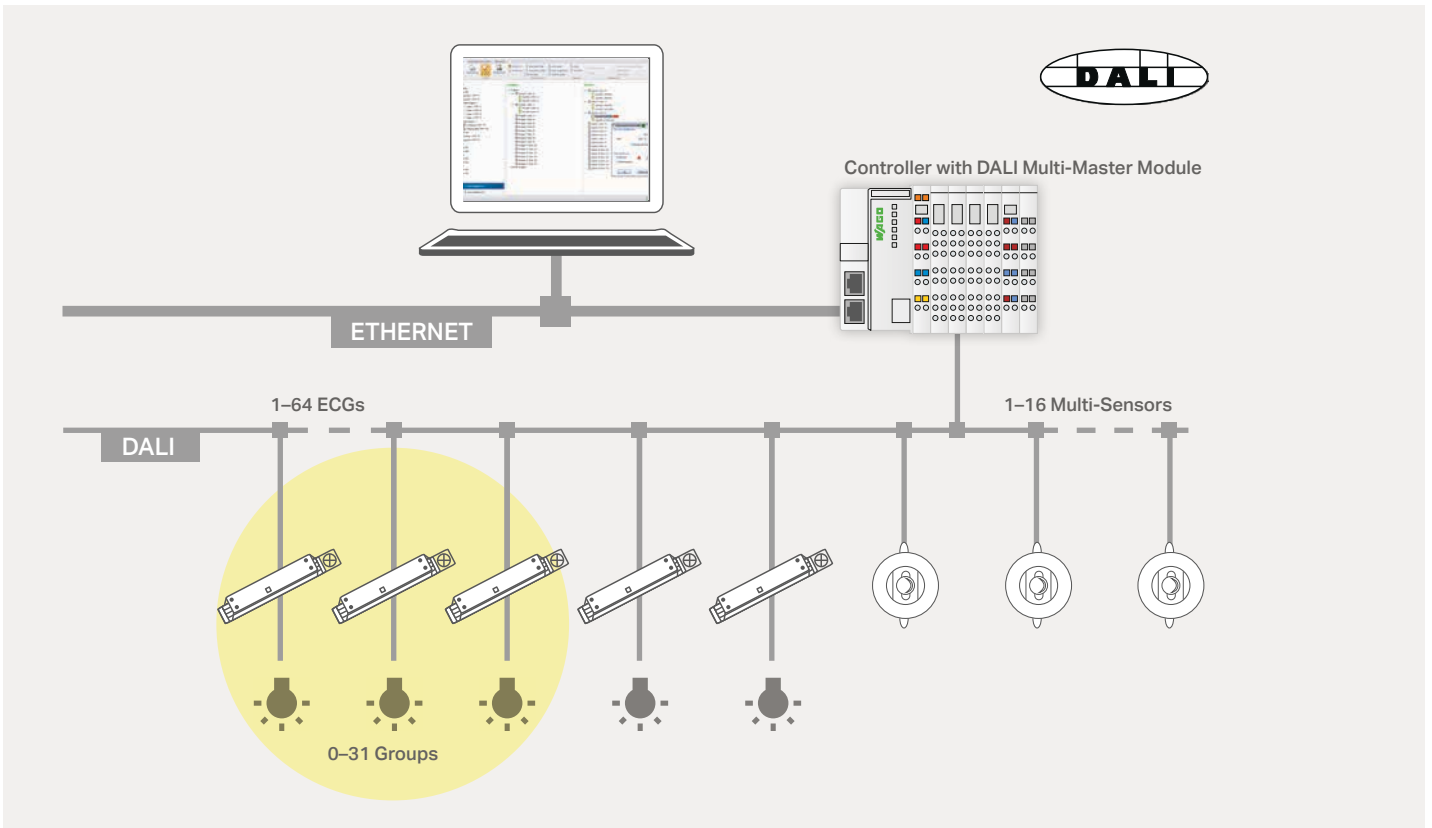
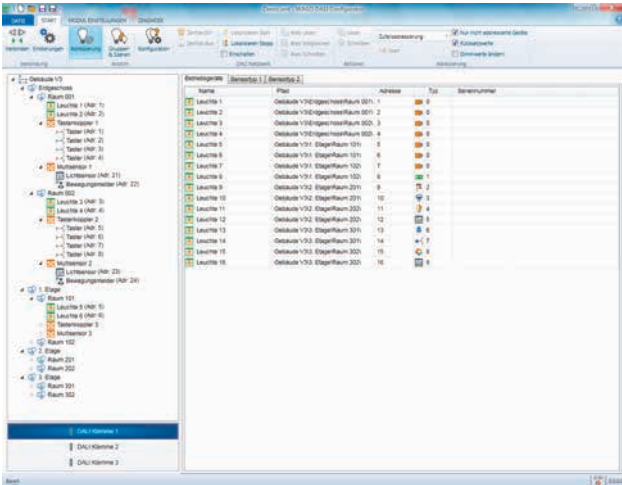

BACnet

Complex Tasks, Managed Quickly

BACnet standardizes communication between products from different manufacturers. Device profiles, services, communication objects, object properties and transmission media have been defined in this standard to meet this goal. WAGO's BACnet Controllers comply with the BACnet Building Controller (B-BC) profile and communicate via **BACnet/IP** or **BACnet MS/TP**.

WAGO BACnet Configurator

The BACnet Configurator is a useful tool for configuring and operating BACnet controllers in a heterogeneous BACnet network. Logically structuring the network and addressing the controller, as well as client and server configuration can be performed on the configuration interface. In addition, the properties of BACnet objects can be accessed using a value browser.

Additional Benefits

Beyond B-BC profile compliance defined in the BACnet Standard, WAGO's freely programmable BACnet Controllers are compatible with the associated, defined BACnet Interoperability Building Blocks (BIBBs). The sheer diversity of available input, output and specialty modules for sub-buses – such as KNX/EIB, MP-Bus and DALI – complete the system, making the WAGO BACnet Controllers very versatile.



© alice_photo/Fotolia.com



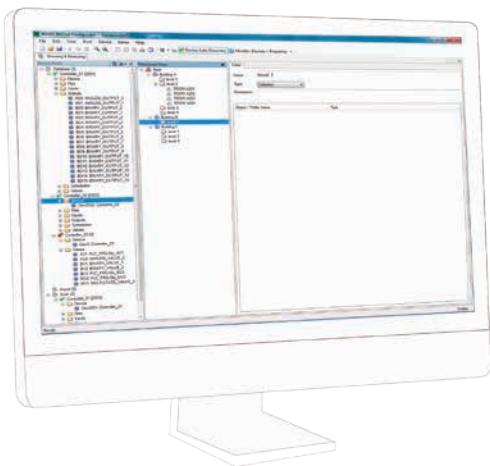
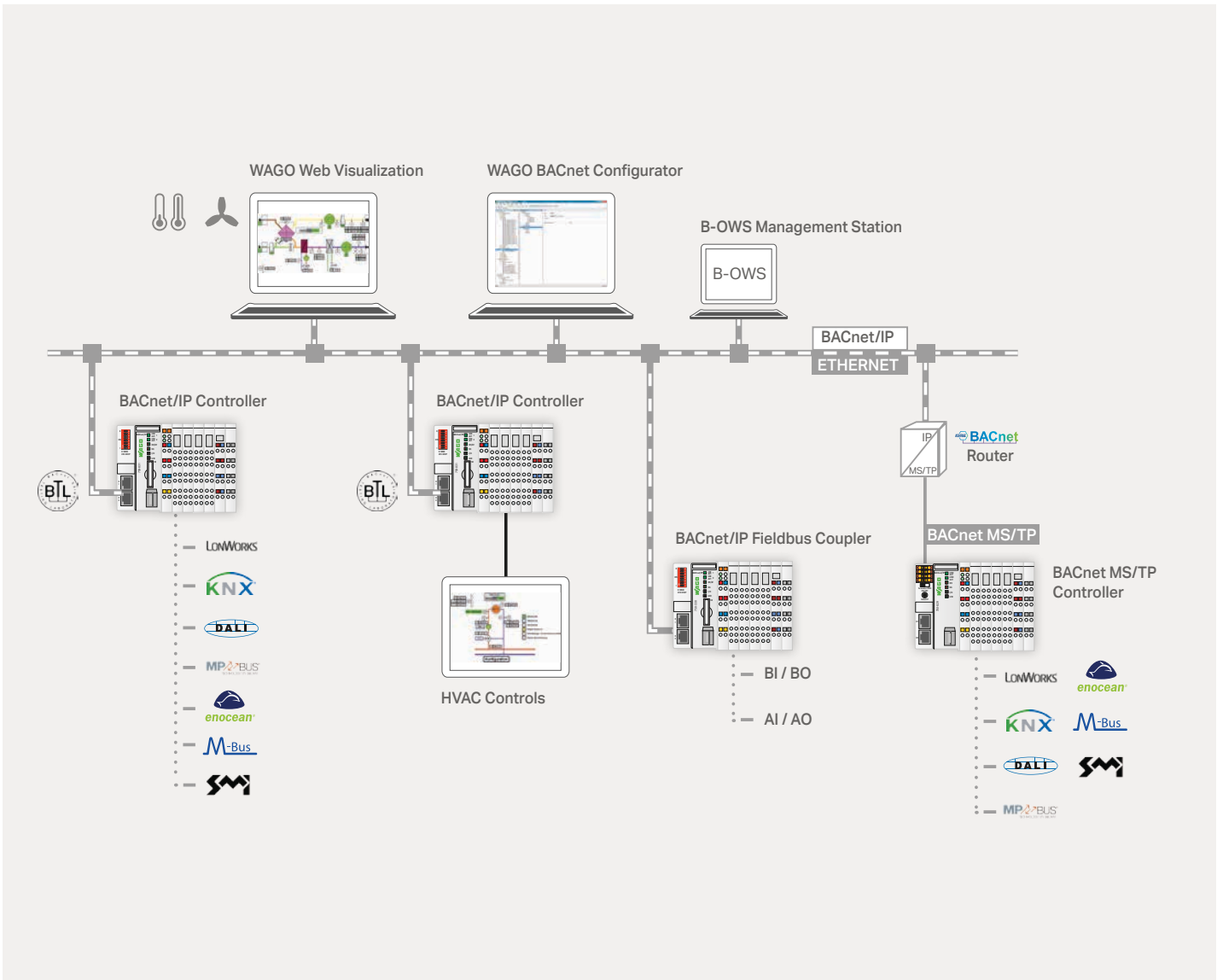



© Roman Sigaev/Fotolia.com

MODBUS TCP/IP

Fast and Lean Communication

Extending 1979's MODBUS protocol for PLCs, the well-established Modbus TCP protocol has become the de facto standard for building automation. The advantage: MODBUS is a streamlined protocol that ensures ultra-fast ETHERNET data transmission. A manufacturer-independent data structure also permits communication between

devices from different manufacturers. Thus, Modbus TCP is recommended for applications that collect data and/or network intelligent controllers with self-sufficient control logic. Therefore, in addition to the respective fieldbus protocol, WAGO's ETHERNET-based controllers for building automation also support Modbus TCP.



ENERGY DATA COLLECTION

Today, systematic energy management is essential for the energy-efficient operation of buildings and systems. Ongoing acquisition and analysis of the actual energy consumption is the foundation for outlining and executing appropriate energy-saving measures. In order to fully maximize efficiency and economy, we must know the exact levels of energy consumption.

The 3-phase power measurement module measures electrical data in a 3-phase supply network. This data makes the energy consumption of a building, its individual areas or systems more transparent to the building operator.

The 3-phase power measurement module can be combined with all building-related WAGO controllers and modules from the WAGO-I/O-SYSTEM 750. The voltage is measured via network connection. The current of the three phases is directly connected to the I/O module at low currents and is fed to the terminals via current transformers at high currents.

In addition to energy consumption measurement, the 3-phase power measurement module also features additional functions for comprehensive grid analysis (e.g., detection of insulation faults, over/under voltage, interference spikes or grid "disturbances"). Based on the values for voltage, current, effective and apparent power consumption, the user is able to reliably measure, evaluate and economize energy consumption.

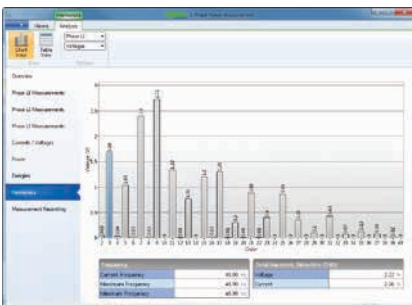
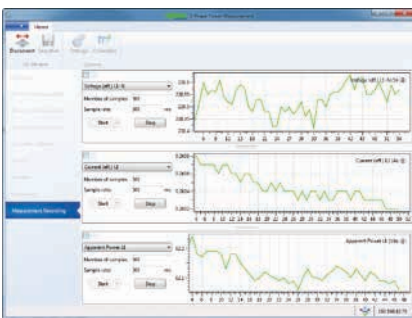
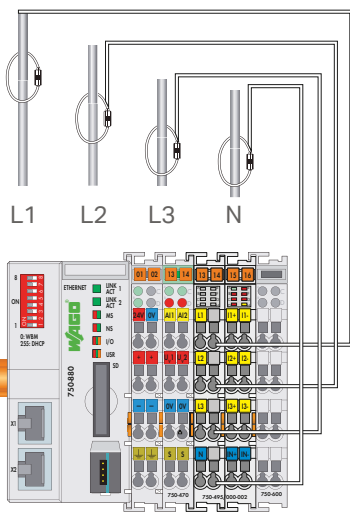



© ekostsov/Fotolia.com

ENOCEAN RADIO TECHNOLOGY

Innovative Concepts for Building Automation

WAGO EnOcean radio technology opens up a new level of innovative building automation solutions, both technically and aesthetically. Radio switches and sensors based on EnOcean technology harvest ambient energy to power themselves. Switches, for example, can be supplied using kinetic energy, and sensors are powered by temperature variations in the environment or with light energy.

Each transmitter has a unique address and communicates with a receiving unit. Despite the limited energy available, these highly efficient electronics can transmit the signal several times, guaranteeing high transmission reliability.

The EnOcean Dolphin system architecture expands the previous system architecture to include sensors and actuators that communicate bidirectionally. The interoperability of EnOcean Dolphin makes it possible to combine products from different manufacturers into one advanced system.



ADDITIONAL TECHNOLOGIES

The WAGO-I/O-SYSTEM provides the user with a wide range of interface solutions for bus systems and subsystems for building automation. Beyond the previously mentioned protocols, WAGO also supports:

LonWorks® technology is standardized per ISO/IEC 14908. In addition to BACnet and KNX, LonWorks® is one of the most important protocols in building automation worldwide. A large number of manufacturers use LonWorks® as a communication protocol, allowing interoperable communication between intelligent devices.

LONWORKS®

The STANDARD MOTOR INTERFACE has the abbreviation SMI and is the standardized electrical interface for electrical drives. SMI was developed for connecting drives with integrated electronic circuits for applications in roller shutters and sun protection systems. The products of different manufacturers can be combined. The interface is highly robust and economical.



DMX is a digital protocol used to control lighting or special stage effects. With the rapid deployment of LED lighting technology, DMX is also used to control LED lights in commercial and utility buildings. DMX displays its strengths in RGB color-control applications (e.g., facade illumination).

DMX

The MP-Bus controls HVAC actuators for dampers, regulator valves or VAV air volume controls. The actuators have connections for sensors (temperature, humidity, ON/OFF switches), which are also accessible via MP-Bus.



The Meter bus (M-bus) is a cost-effective fieldbus for transmitting energy consumption data. A central master – in the simplest case, a WAGO controller with downstream level inverter – communicates via a two-wire bus (up to max. 250 slaves per segment) with bus devices (e.g., heat meter, water meter, electric meter, gas meter), as well as all sensor and actuator types.

M-Bus





SUMMARY

This Brochure is Just the Start

All product and user information, as well as library solutions and applications found in this brochure, are state-of-the-art.

However, WAGO is continually developing product extensions, evolving technology and providing both useful details and process solutions. Furthermore, WAGO's customers are continuously combining their ingenuity with our innovations to create interesting applications that benefit all.

This brochure was developed to serve as a long-term reference guide. However, we offer continuously updated information about WAGO building automation on our Web site.

WAGO's Web Site Provides Current Information

At www.wago.com, we have set up a portal with up-to-date information and references: Go to "Solutions > Building Automation."

Go to "Services > Downloads" at www.wago.com to obtain the latest documents, data sheets and application notes.

WAGO Kontakttechnik GmbH & Co. KG

Postfach 2880 · 32385 Minden
Hansastraße 27 · 32423 Minden
info@wago.com
www.wago.com

Headquarters	+49 571/ 887 - 0
Sales	+49 571/ 887 - 222
Order Service	+49 571/ 887 - 44333
Fax	+49 571/ 887 - 8 44169

WAGO is a registered trademark of WAGO Verwaltungsgesellschaft mbH. Cover picture: iStock.com/Fabian Wentzel

“Copyright – WAGO Kontakttechnik GmbH & Co. KG – all rights reserved. The content and structure of the WAGO websites, catalogs, videos, and other WAGO media are subject to copyright. Distribution or modification to the contents of these pages and videos is prohibited. Furthermore, the content may neither be copied nor made available to third parties for commercial purposes. Also subject to copyright are the images and videos that were made available to WAGO Kontakttechnik GmbH & Co. KG by third parties.”