

Marine and Offshore



Contents

Marine and Offshore	4
From the Bridge to the Engine Room	6
Alarm and Monitoring Systems	8
Perfectly in Balance	10
Deck and Cargo Handling	12
Full Speed Ahead	14
Cabin Distribution	16
Our Lab Tests	18
The WAGO Tool Chain	20
WAGO Product Information	22



Dosch Design, processed

MARINE AND OFFSHORE

WAGO, your reliable partner for marine technology

Safe, reliable and robust components – tested, and approved.

Whether freighter or mega yacht, all types of ships face the same tough requirements at sea. Our automation and connection technologies meet the most challenging requirements on the high seas. Confirmed by the stamp of classification associations from the IACS Association,

WAGO products have proven their strength and durability, ability to withstand extreme temperatures and electromagnetic compatibility (EMC), as well as vibration and shock resistance.

These same components also fulfill the requirements for hazardous environments in accordance with IECex and other governing bodies.





Dosch Design, processed

FROM THE BRIDGE TO THE ENGINE ROOM

WAGO is at home in all of these applications

**From the bridge to the engine room –
Automated and reliably connected with WAGO
products**

Our marine automation and offshore sector products automate nearly every application on board. Propulsion automation, auxiliary and deck machinery, navigation and communication equipment: Every application has its own special requirements. The answer for continually meeting all of these requirements is WAGO's relays, optocou-

plers, signal conditioning modules, power supplies and network switches. The TOPJOB® S Rail-Mount Terminal Blocks cover conductor sizes from 0.08 to 185 mm² – this creates a broad platform for electrical connection technology in marine applications. The same also applies to the more than four hundred modules found in the WAGO-I/O-SYSTEM 750. Special certificates (BSH, near the compass) enable these components to be used everywhere from the bridge to the bilge.



Exhaust Gas Cleaning

Cabins & Accommodation (HVAC)

Navigation & Communication

Rescue Equipment

Anchor Winches

Winches

Propulsion Control

SAFE AND RELIABLE IN ALL APPLICATIONS

- Bridge approval based on IEC EN60945
- Classified for extreme environmental conditions (EMC 1/Cat. D)
- Low logistic and training costs
- Broad application scope for the WAGO-I/O-SYSTEM 750



shutterstock.com/Jeanette Dietl

Topology of a ring-network-based alarm and monitoring system

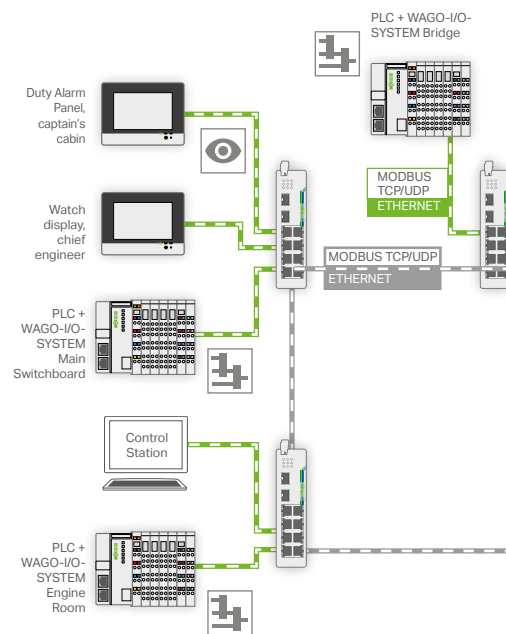

ALARM AND MONITORING SYSTEMS

All signals in view – ship monitoring with WAGO products

Collecting, conditioning, visualization and notifications/alarms – routine, yet important, tasks that the WAGO-I/O-SYSTEM easily handles.

As an engineering planner, you can implement any conceivable configuration in different network topologies using the modular building blocks of the WAGO-I/O-SYSTEM 750. Whether configuring decentralized intelligence or a central control system with a powerful PLC, a digital or analog signal, valve control or light scenarios for a pleasant ambience, our comprehensive automation portfolio lets you create custom solutions.

The *e!COCKPIT* engineering platform supports you throughout your products' life cycle.

Mapping entire topologies and processing multi-controller systems is perfectly compatible with the processing of alarm and monitoring systems with up to 10,000 measuring points.

Visualization is based on HTML5 and can be displayed on WAGO displays or on mobile devices.

Monitoring system with distribution board

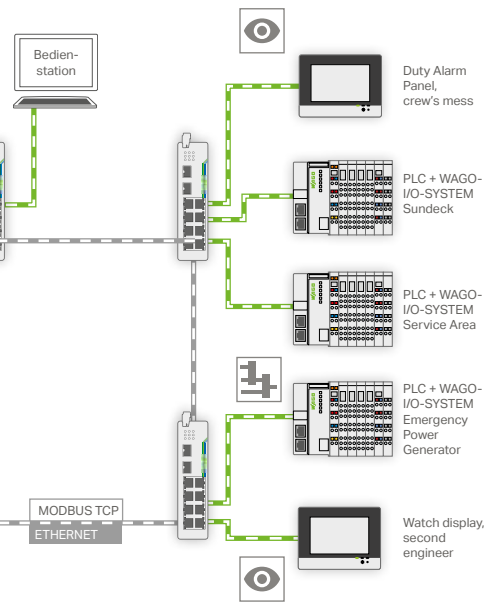

Works photo besecke

ALARM AND MONITORING SYSTEMS

- Modular, distributed
- Bus-independent, scalable
- Network technology and automation from a single source





shutterstock.com/lan Holland

Topology of a tank ballast system with a du

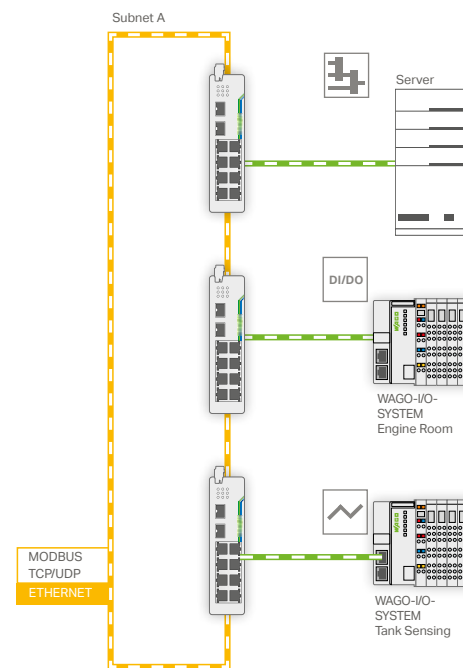

PERFECTLY IN BALANCE

Automation for tank ballast and cargo management systems

Maintaining stability in rough seas is vital for freighters.

A reliable tank ballast system is a ship's life insurance against incorrect trim, heel or draught. The anti-heeling system can automate a number of steps for this essential function. Rapid loading and unloading can be dramatically simplified with an automated cargo management system. Ensure safe, uninterrupted running of processes in the event of a fault with a WAGO automation-equipped emergency shutdown system. This solution for protecting people and the environment has long

been standard equipment for German- and Italian-built cruise ships. Global shipping has made the protection of native species an increasingly important issue. Microorganisms are transported from one biosphere to another in ballast water and can upset the delicate balance of nature. The IMO Convention for the treatment of ballast water has defined limits for this that can only be maintained using filter systems. A modular, efficient and effective setup with WAGO components will help you minimize the additional costs associated with this.

TANK AND BALLAST SYSTEMS

- General purpose use
- Distributed, modular and approved for use on ships
- Visualization with varying levels of authorization

Cargo Management	Anti-Heeling System	Alarm and Monitoring System	Emergency Shutdown System
Tank Ballast Control	Tank Sensing Systems	Ballast Water Treatment	Emergency Stop Valve Control
Valves, Pumps and Tank Measuring Sensors		Pumps, Filter Systems	SOS Valves

Ring and central processing

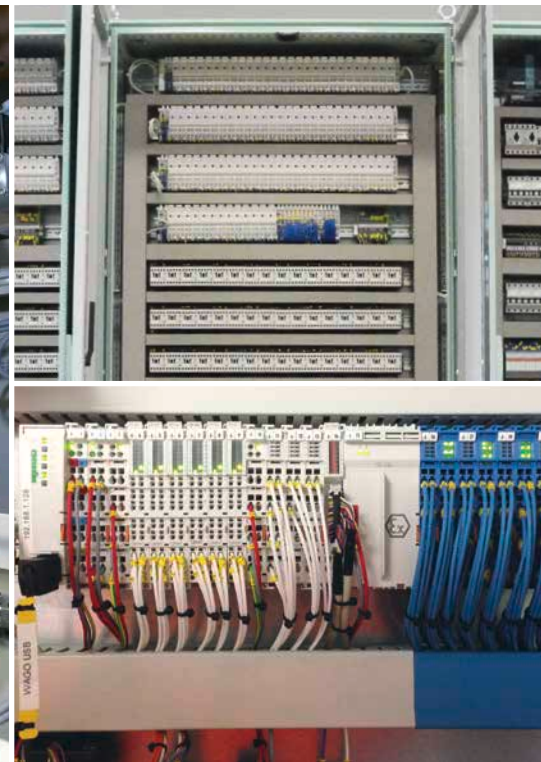
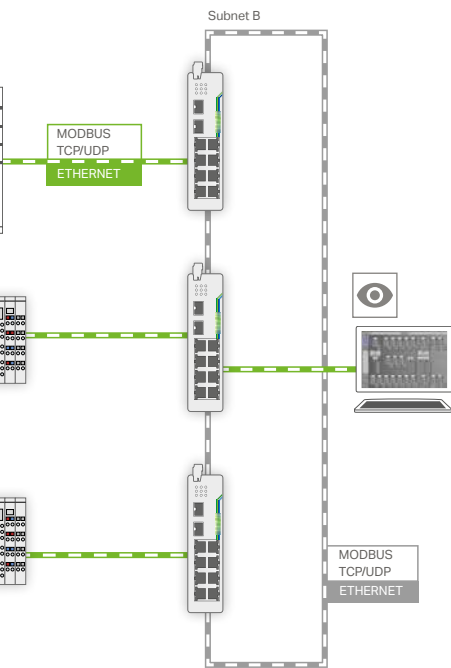

Left: works photo, Besi; top right: Besi, bottom right: MIFO

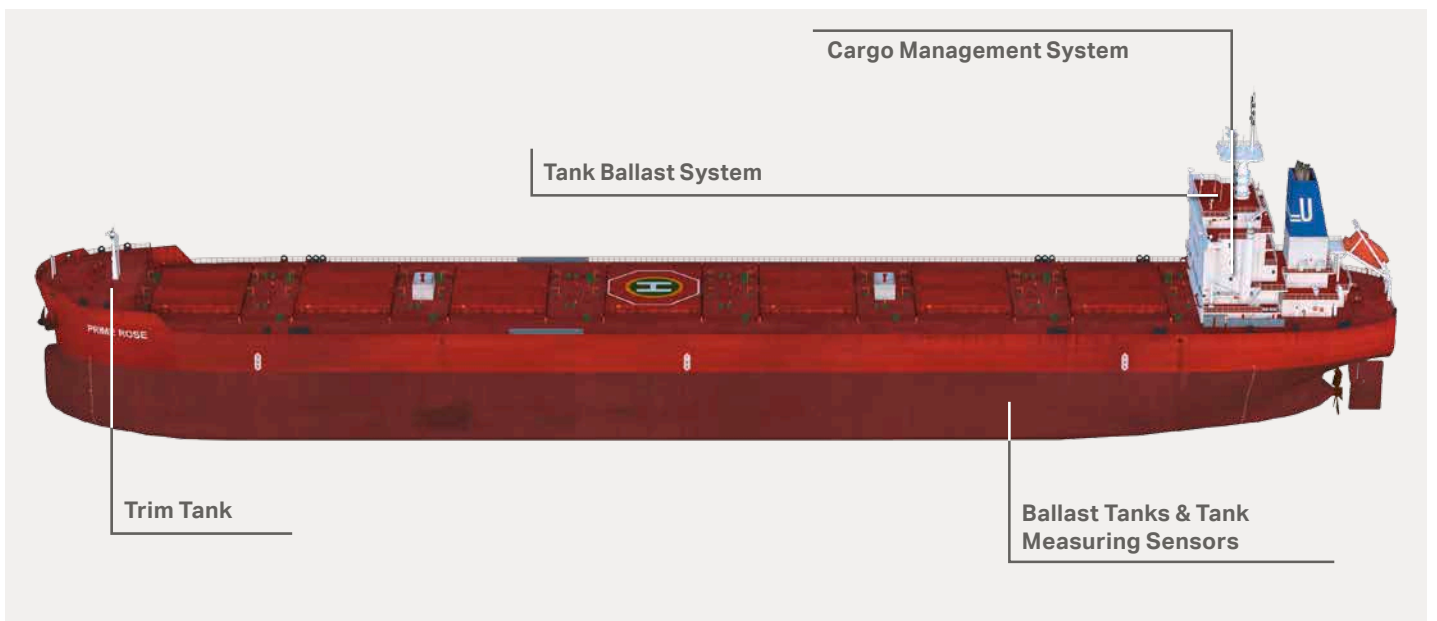

Dosch Design, processed

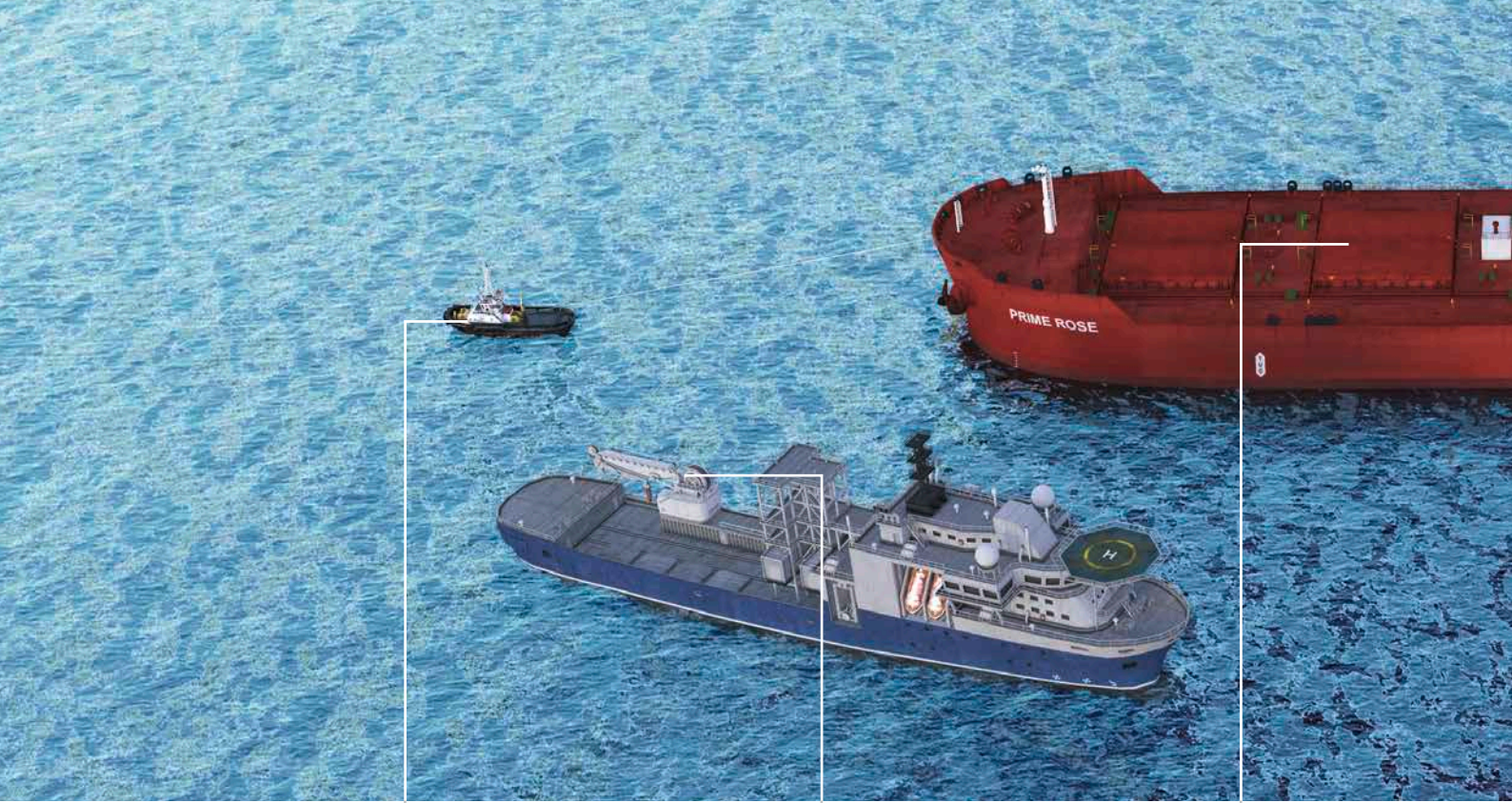

Dosch Design, processed



© chrisberic/ Fotolia.com



© panalot/ Fotolia.com

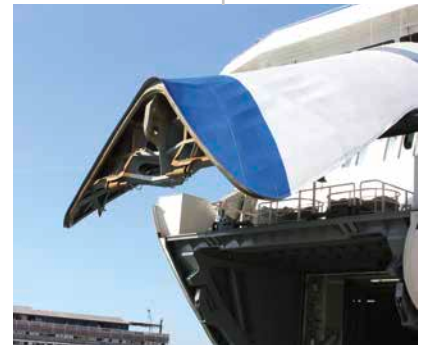

© rbkelle/ Fotolia.com

DECK AND CARGO HANDLING

All the hatches are closed and the cargo is secured

In rough seas or in environmental protection zones, modern tugboats must escort larger ships safely into port.

Time is money – in the truest sense of the word – and you have a competitive edge when you can offer your services as frequently as possible and nearly “around the clock.” A high degree of automation for winches and other machines on deck gives you the best possible protection when ma-

neuvering at sea. The same holds true for loading and unloading with cranes and gangway systems at offshore wind farms or oil drilling platforms. A highlight here is the direct control of proportional valves, making expensive valve drivers and proprietary solutions a thing of the past. Parameterization moves into automation at the point where the tool chain is available.

DECK AND CARGO HANDLING

- Direct valve control from the WAGO-I/O-SYSTEM
- CODESYS controller library
- Set parameters for proportional valves using WAGO-I/O-CHECK



Setpoint ramps

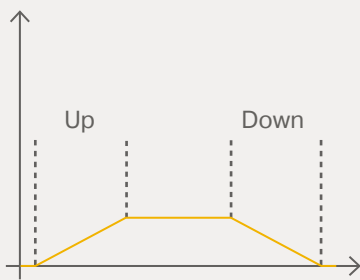

Valve adjustment

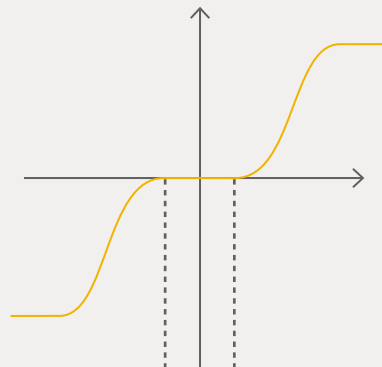

Dithering

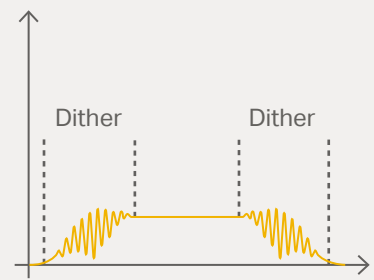

Operating modes

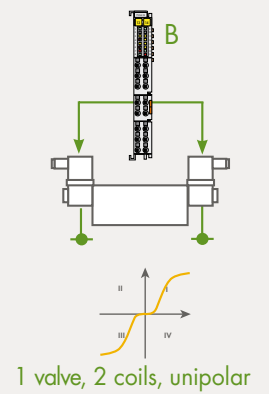
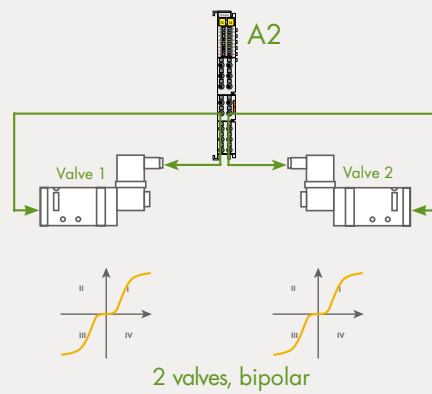
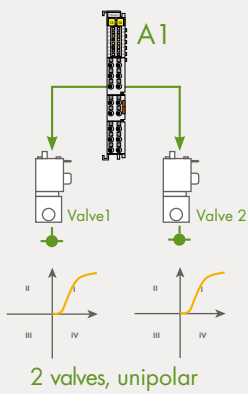

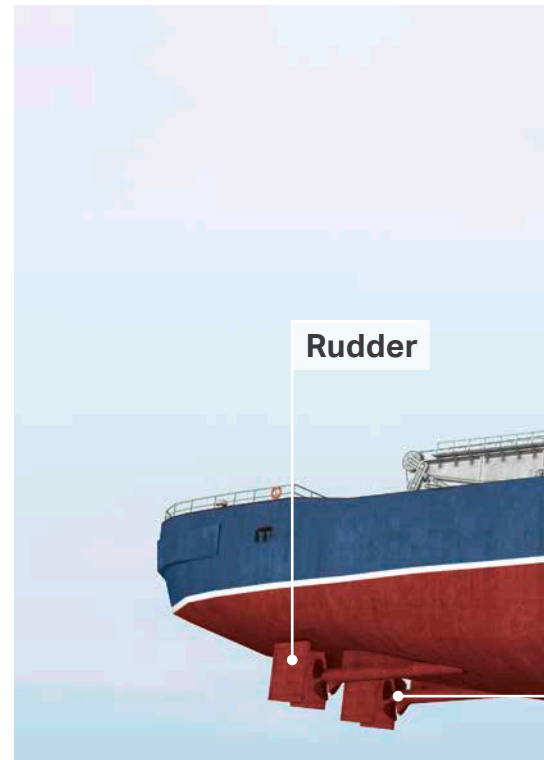
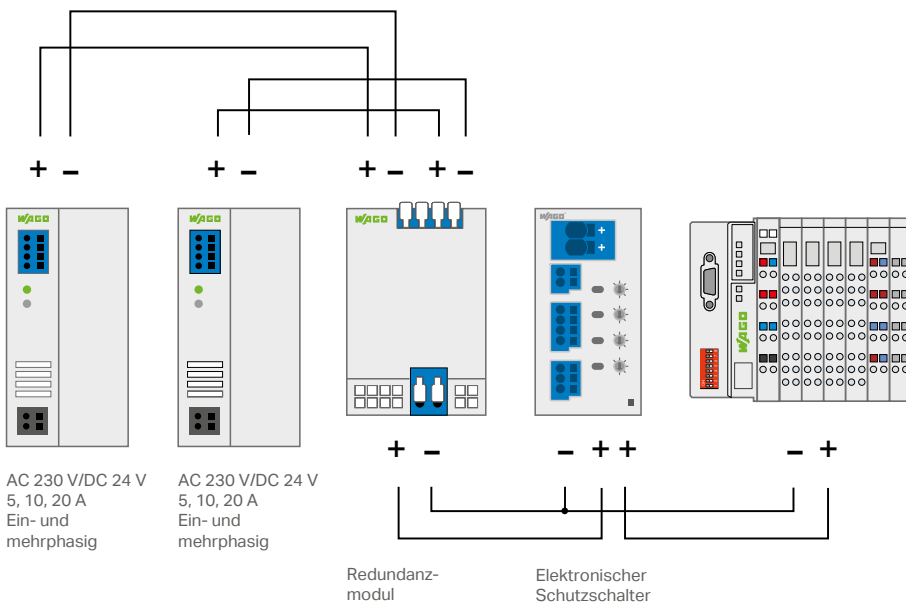

Dosch Design, processed

FULL SPEED AHEAD

**Whether you have a diesel engine with exhaust gas cleaning or a hybrid propulsion system:
The propulsion automation system comes from WAGO**

Marine propulsion technology is being put to the test.

Buzzwords and terms such as slow steaming, dual fuel, exhaust gas reduction, hybrid propulsion or LNG as a fuel are behind the requirements that are increasing powertrain complexity. In this light, demands for intelligent automation solutions make perfect sense. The portfolio for the intrinsically safe WAGO-I/O-SYSTEM 750 enables you to automate LNG drives or retrofit scrubber and filter systems for exhaust gas reduction. The 750 XTR Series components are specially designed for extreme hot or cold ambient temperatures

and performance under extreme vibration or EMC conditions. Overview of exhaust gas standards
Our power supply modules are designed for more stringent availability and reliability requirements. In the event of a fault, single and multi-phase power supplies and buffer modules ensure the availability of the automation system. Protection of the secondary circuits is conveniently provided via remote-controlled electronic fuses. Energy measurement terminal blocks for diesel electric drives and a rich portfolio of signal converters and signal amplifiers complete the program.

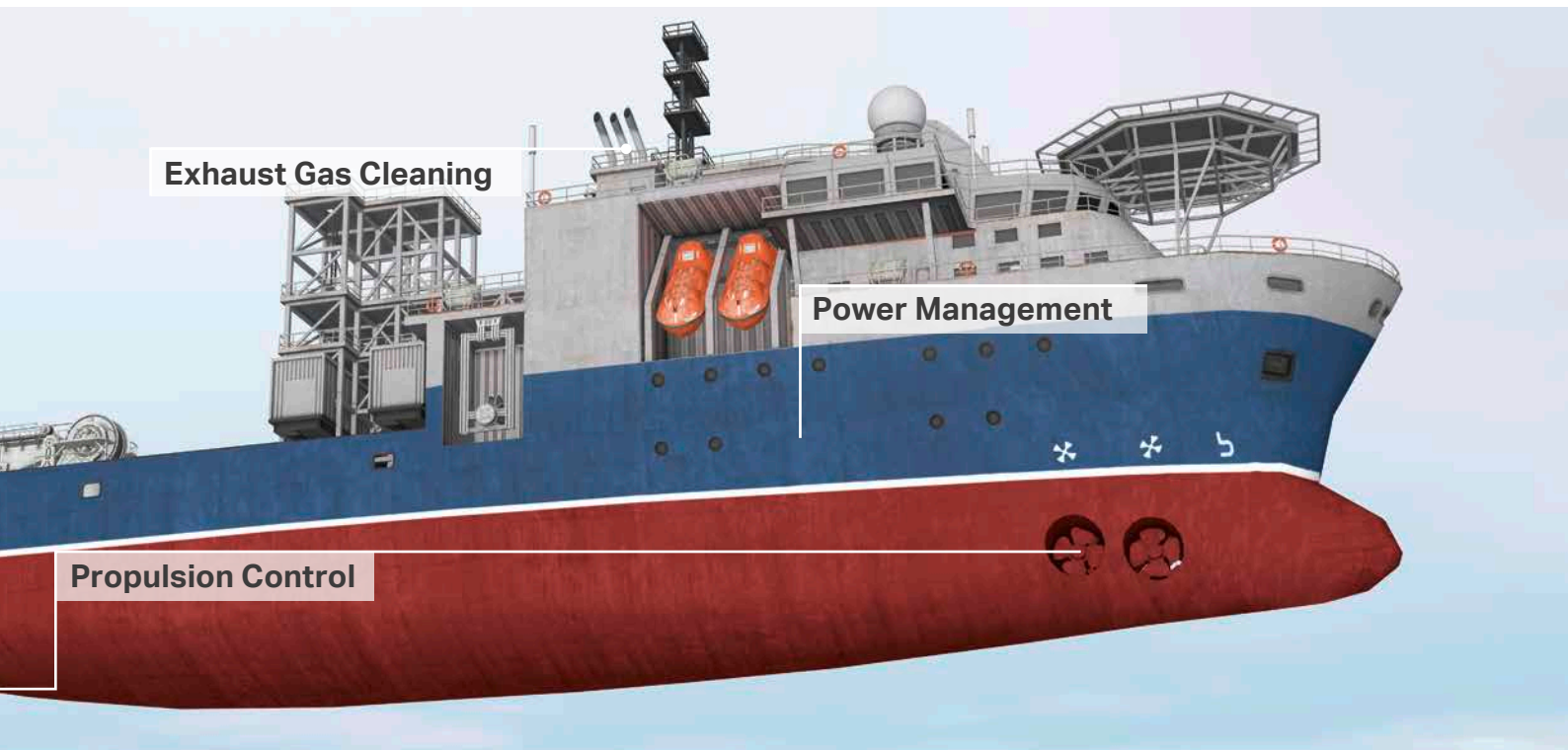

MARPOL Annex 6: Fuel Sulfur Content		
Time	Upper limit for fuel sulfur content (%)	
	SOx ECA *)	Rest of World
2000	1.5 %	4.5 %
July 2007	1.0 %	
2012		3.5 %
2015	0.1 %	
2020 **)		0.5%

MARPOL Annex 6: Nitrogen Oxide Emission Limits				
Tier	Time	NOx limit g/kW		
		n < 130	130 <= n < 2000	n >= 2000
Tier I	2000	17.0	45 * n ^{-0.2}	9.8
Tier II	2011	14.4	44 * n ^{-0.23}	7.7
Tier III	2016 *)	3.4	9 * n ^{-0.2}	1.96

Overview of exhaust gas standards



The WAGO-I/O-SYSTEM 750 XTR is temperature-resistant from -40 °C to +70 °C, vibration-proof up to 5g and features high impulse-voltage withstand according to EN 60870-2-1.

PROPULSION AND RUDDER SYSTEMS

- Intrinsically safe modules for sensors in Zone 2
- Marine-compliant power supply design
- Signal conversion and automation from a single source



Ingrid Fiebak-Kremer

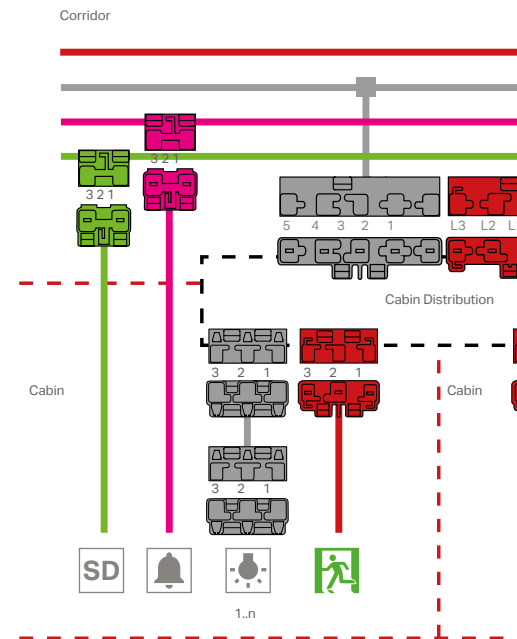

CABIN DISTRIBUTION

The floating hotel – safety and functionality

Cruises are becoming more and more popular, prompting a justifiable rise in demands for comfort and safety.

The WINSTA® pluggable connection system for electrical distribution is instrumental for the safety and reliability of on board plugged connections. The plugs are pre-assembled under carefully controlled conditions in the workshop. This is a win-win situation: Enhancing wiring quality and

minimizing expensive, on board installation times. Cabin distribution or the dining area – lighting manufacturers are increasingly relying on PCB plugs and sockets from the WINSTA® line.

An ideal complement to the WINSTA® line is the X-COM® plug-in system for rapid plug-and-play control cabinet installations. Two products that perfectly complement one another.

CABIN INSTALLATION

WINSTA® and X-COM®:

- Color-coded
- Mechanically coded
- Reduced effort on board

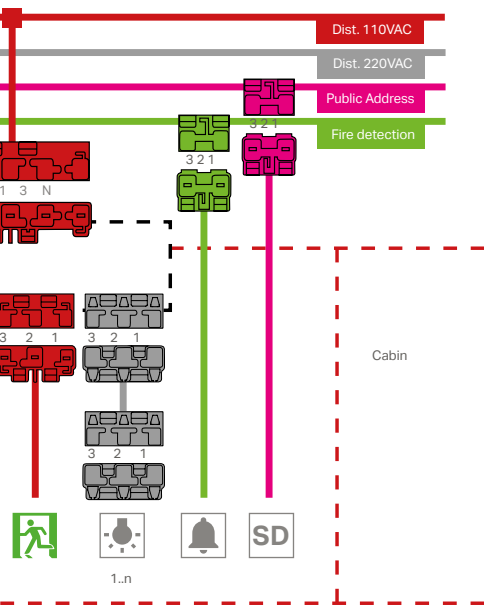

Ingrid Fiebak-Kremer

The benefits of the WAGO-I/O-SYSTEM are also evident in cabin distribution: Easily program switching and control functions using the comprehensive libraries that are available. Use *e!COCKPIT* to easily program and start up multi-controller systems. Repeated errors are avoided and the reusability of code is improved by the new object orientation.

CABIN AUTOMATION

WAGO-I/O-SYSTEM:

- Modular and distributed
- Access to building automation libraries
- Flexible for signals and bus protocols



DGzRS/Helmut Hofer

OUR LAB TESTS

Recreating tough challenges in rough seas

Quality results from experience and uncompromising attention to detail.

As the world market leader and inventor of screwless connection technology, we offer the broadest range of rail-mounted terminal blocks with

Spring Pressure Connection Technology, covering a wire range between 0.08–185 mm². We can also boast that years of experience have proven that our maintenance-free clamping units remain secure – even after 35 years!



Vibration test



Climatic chamber



Salt spray test



Proven Quality Thanks to Certified Processes and Products.

We don't just promise that our products meet the highest quality standards, you also get this in black and white in the form of internationally

recognized certificates. Beyond the requirements outlined by DIN ISO 9001:2000 and ISO 14001, WAGO also fulfills the requirements set forth by all requisite maritime approvals: DNVGL, ABS, LRS, BV, KRS, classNK.



Gastight clamping unit

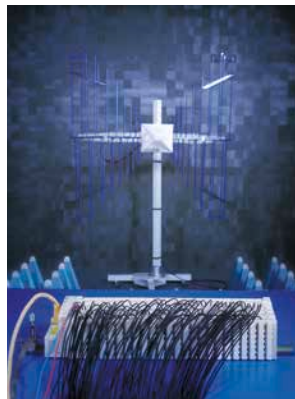

EMC Vibration test Climatic chamber Salt spray test Gastight clamping unit tests

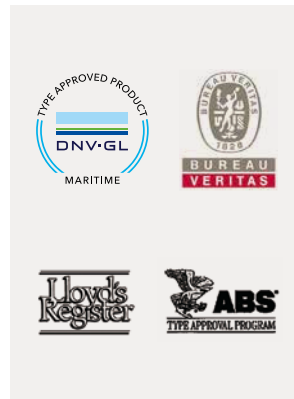

Approvals (Excerpt)

THE WAGO TOOL CHAIN

Accelerate your development process

Timely engineering is an essential factor for success in today's globally networked world.

You must be able to adapt to your customers' needs and demands in order to tap into new markets and keep ahead of competitors. WAGO supports you in these efforts with an end-to-end tool chain. **smartDESIGNER** accompanies you through all phases of control cabinet engineering – with bidirectional interfaces to CAE systems, **smartPRINTER**

and, of course, to WAGO's eShop. As a result, the management of master data and parts lists can be done at one single point.

e!COCKPIT invites you to discover: Your entire project in view, from graphic network design up to the parameterization and diagnostics of the WAGO-I/O-SYSTEM 750, standard-compliant programming in CODESYS 3.5, modern visualization in HTML5.

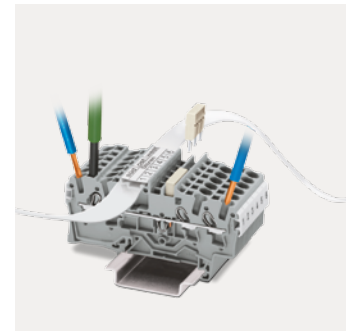
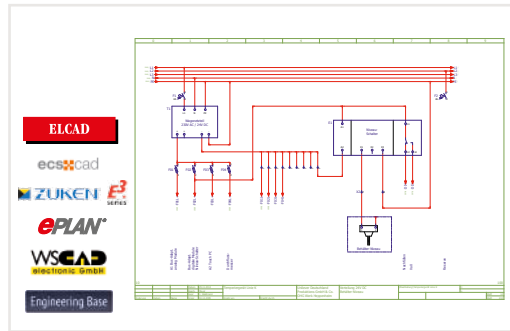
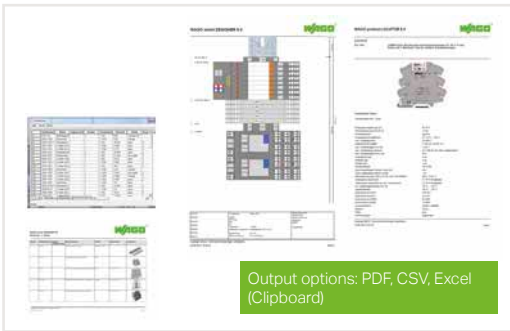

Control cabinet engineering: **smartDESIGNER**

Design

Manufacturing

Program

Automation: **e!COCKPIT**

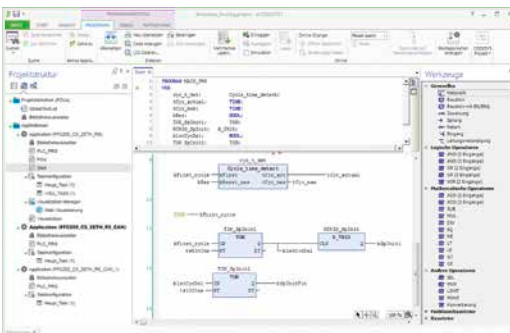

Continuous support

- **e!COCKPIT** for integrated engineering
- in automation
- **smartDESIGNER** for the life cycle of a control cabinet
- Seamless integration into CAE systems

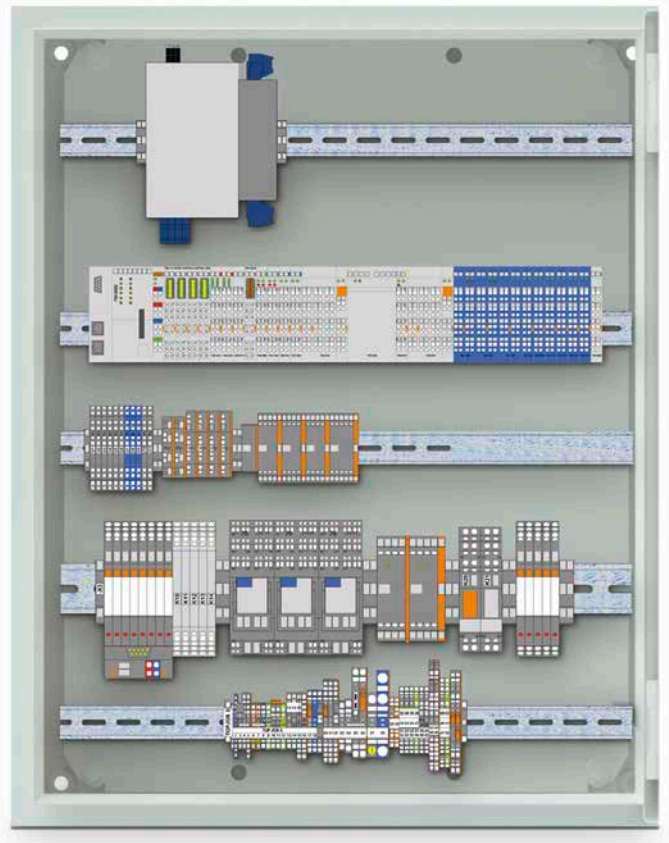
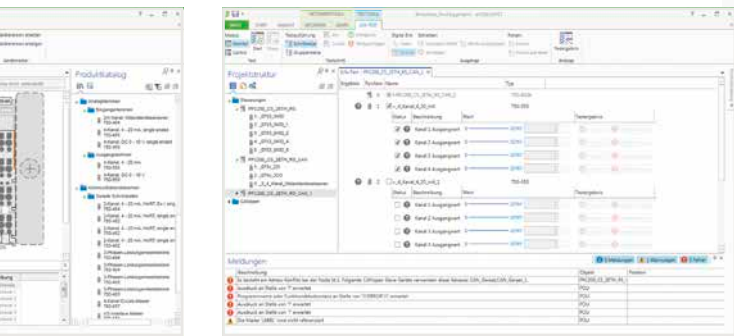

WAGO PRODUCT INFORMATION

All WAGO products shown in this brochure are available in the following WAGO full line catalogs:

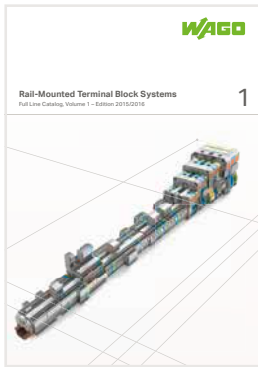

Volume 1, Rail-Mounted Terminal Block Systems

- DIN-rail-mount terminal blocks
- Modular Connectors (X-COM®-SYSTEM and X-COM®S-SYSTEM)
- Patchboard Systems
- Terminal Strips
- PUSH WIRE® Connectors for Junction Boxes
- Lighting Connectors
- Shield Connecting System

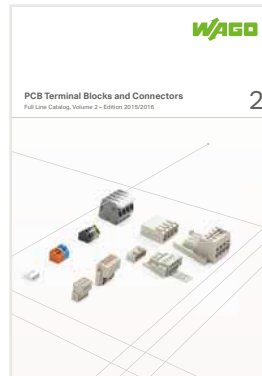

Volume 2, PCB Terminal Blocks and Connectors

- PCB Terminal Blocks
- Feedthrough Terminal Blocks
- *MULTI CONNECTION SYSTEM (MCS)*
- Pluggable PCB Terminal Blocks
- Specialty Connectors

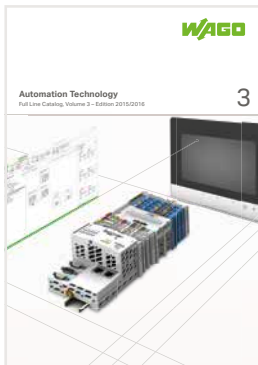

Volume 3, AUTOMATION

- IP20 Modular I/O-SYSTEM
- Radio Technology, *TO-PASS®* Telecontrol Technology
- Industrial Switches, *PERSPECTO®*
- Modular IP67 I/O-SYSTEM, IP67 Block I/O-SYSTEM
- IP67 Sensor/Actuator Boxes, IP67 Cables and Connectors
- Power Supplies

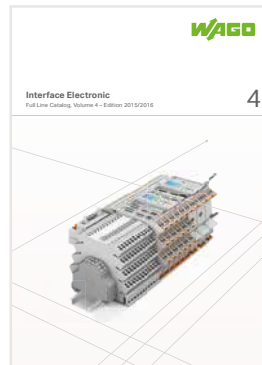

Volume 4, INTERFACE ELECTRONIC

- Relays – Optocouplers – Specialty Functions
- Interface Modules
- Signal Conditioners
- Power Supplies
- Overvoltage Protection
- Radio Technology
- Empty Housings and DIN-Rail-Mount Carriers



Volume 5, WINSTA® – The Pluggable Connection System

- WINSTA® MINI – Pluggable Connectors
- WINSTA® MINI special – Pluggable Connectors
- WINSTA® MIDI – Pluggable Connectors
- WINSTA® MIDI special – Pluggable Connectors
- WINSTA® MAXI – Pluggable Connectors
- WINSTA® RD – Cable Assemblies
- WINSTA® KNX – Pluggable Connectors
- WINSTA® IDC – Flat Cable Systems



An overview of our catalogs is available at:
<http://global.wago.com/en/products/product-catalog/overview/index.jsp>



Marks of approval:

ABS (American Bureau of Shipping)

BV (Bureau Veritas)

DNV (Det Norske Veritas)

KR (Korean Register)

LR (Lloyds Register)

NKK (Nippon Kaiji Kyokai)

RINA (Registro Italiano Navale)

EX (Explosion Protection)

IECEx (International Electrotechnical Commission Explosion Protection)

WAGO Kontakttechnik GmbH & Co. KG
Postfach 2880 · 32385 Minden
Hansastraße 27 · 32423 Minden
info@wago.com
www.wago.com

Headquarters	+49 571/ 887 - 0
Sales	+49 571/ 887 - 222
Order Service	+49 571/ 887 - 44333
Complaint	+49 571/ 887 - 77666
Fax	+49 571/ 887 - 8 44169

WAGO is a registered trademark of WAGO Verwaltungsgesellschaft mbH.

"Copyright – WAGO Kontakttechnik GmbH & Co. KG – All rights reserved. The content and structure of the WAGO websites, catalogs, videos, and other WAGO media are subject to copyright. Distribution or modification to the contents of these pages and videos is prohibited. Furthermore, the content may neither be copied nor made available to third parties for commercial purposes. Also subject to copyright are the images and videos that were made available to WAGO Kontakttechnik GmbH & Co. KG by third parties."