

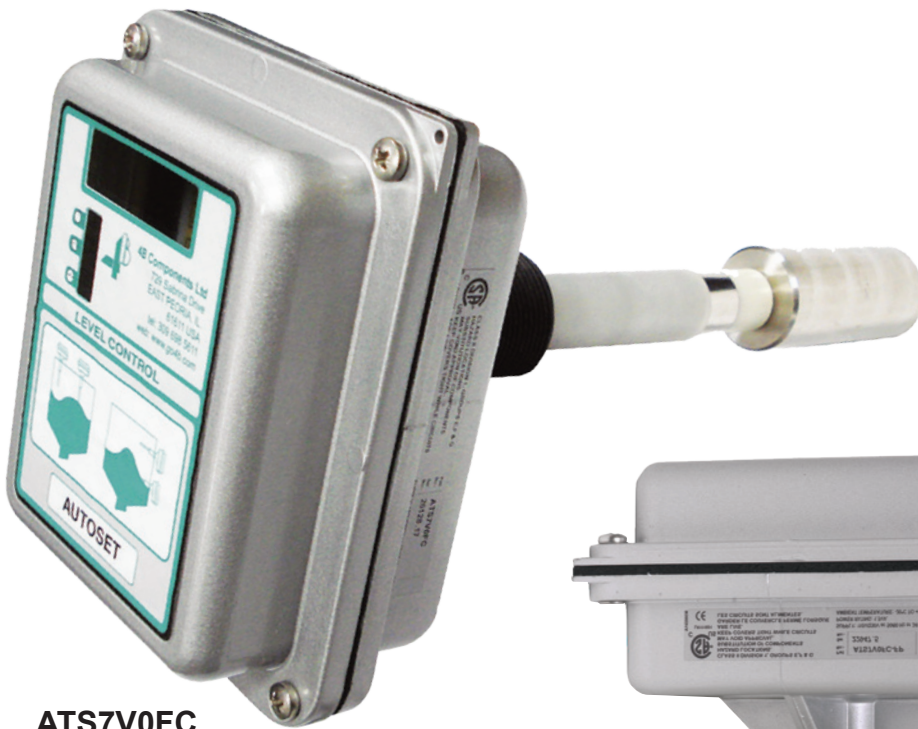

Auto-Set™

RADIO FREQUENCY (RF) CAPACITANCE
POINT LEVEL INDICATOR



AT57V0FC



AT57V0FC-FP



INSTALLATION INSTRUCTIONS

OPERATION MANUAL

Part No's AT57V0FC, AT57V0FC-300, AT57V0FC-400, AT57V0FC-FP

www.go4b.com/usa

TABLE OF CONTENTS

CUSTOMER SAFETY RESPONSIBILITIES	Page 4 - 5
PRODUCT OVERVIEW	Page 6
SPECIFICATIONS	Page 6
DIMENSIONS	Page 7 - 8
INSTALLATION	Page 8 - 9
STANDARD WIRING DIAGRAM	Page 10
SENSOR OPERATION	Page 11 - 12
SENSOR CALIBRATION	Page 13 - 14
POWER SHIELD OVERVIEW	Page 15
TESTING AND COMMISSIONING	Page 16
TROUBLESHOOTING GUIDE	Page 16
PARTS AND ACCESSORIES	Page 17
PRODUCT WARRANTY	Page 19

Dear 4B Customer:

Congratulations on your purchase. 4B appreciates your business and is pleased you have chosen our products to meet your needs.

Please read in its entirety and understand the literature accompanying the product before you place the product into service. Please read the safety precautions carefully before operating the product. With each product you purchase from 4B, there are some basic but important safety considerations you must follow to be sure your purchase is permitted to perform its design function and operate properly and safely, giving you many years of reliable service. Please read and understand the Customer Safety Responsibilities listed below. Failure to follow this safety directive and the Operation Manuals and other material furnished or referenced, may result in serious injury or death.

SAFETY NOTICE TO OUR CUSTOMERS

- A. In order to maximize efficiency and safety, selecting the right equipment for each operation is vital. The proper installation of the equipment, and regular maintenance and inspection is equally important in continuing the proper operation and safety of the product. The proper installation and maintenance of all our products is the responsibility of the user unless you have asked 4B to perform these tasks.
- B. All installation and wiring must be in accordance with Local and National Electrical Codes and other standards applicable to your industry. (Please see the article “Hazard Monitoring Equipment Selection, Installation and Maintenance” at www.go4b.com.) The installation of the wiring should be undertaken by an experienced and qualified professional electrician. Failure to correctly wire any product and/or machinery can result in the product or machine failing to operate as intended, and can defeat its design function.
- C. Periodic inspection by a qualified person will help assure your 4B product is performing properly. 4B recommends a documented inspection at least annually and more frequently under high use conditions.
- D. Please see the last page of this manual for all warranty information regarding this product.

CUSTOMER SAFETY RESPONSIBILITIES

1. READ ALL LITERATURE PROVIDED WITH YOUR PRODUCT

Please read all user, instruction and safety manuals to ensure that you understand your product operation and are able to safely and effectively use this product.

2. YOU BEST UNDERSTAND YOUR NEEDS

Every customer and operation is unique, and only you best know the specific needs and capabilities of your operation. Please call the 24-hour hotline at 309-698-5611 for assistance with any questions about the performance of products purchased from 4B. 4B is happy to discuss product performance with you at any time.

3. SELECT A QUALIFIED AND COMPETENT INSTALLER

Correct installation of the product is important for safety and performance. If you have not asked 4B to perform the installation of the unit on your behalf, it is critical for the safety of your operation and those who may perform work on your operation that you select a qualified and competent electrical installer to undertake the installation. The product must be installed properly to perform its designed functions. The installer should be qualified, trained, and competent to perform the installation in accordance with Local and National Electrical Codes, all relevant OSHA Regulations, as well as any of your own standards and preventive maintenance requirements, and other product installation information supplied with the product. You should be prepared to provide the installer with all necessary installation information to assist in the installation.

4. ESTABLISH AND FOLLOW A REGULAR MAINTENANCE AND INSPECTION SCHEDULE FOR YOUR 4B PRODUCTS

You should develop a proper maintenance and inspection program to confirm that your system is in good working order at all times. You will be in the best position to determine the appropriate frequency for inspection. Many different factors known to the user will assist you in deciding the frequency of inspection. These factors may include but are not limited to weather conditions; construction work at the facility; hours of operation; animal or insect infestation; and the real-world experience of knowing how your employees perform their jobs. The personnel or person you select to install, operate, maintain, inspect or perform any work whatsoever, should be trained and qualified to perform these important functions. Complete and accurate records of the maintenance and inspection process should be created and retained by you at all times.

5. RETAIN AND REFER TO THE OPERATION MANUAL FOR 4B'S SUGGESTED MAINTENANCE AND INSPECTION RECOMMENDATIONS

As all operations are different, please understand that your specific operation may require additional adjustments in the maintenance and inspection process essential to permit the monitoring device to perform its intended function. Retain the Operation Manual and other important maintenance and service documents provided by 4B and have them readily available for people servicing your 4B equipment. Should you have any questions, please call the free 24-hour hotline number (309-698-5611).

6. SERVICE REQUEST

If you have questions or comments about the operation of your unit or require the unit to be serviced please contact the 4B location who supplied the product or send your request via fax (309-698-5615) or call us via our 24-hour hotline number in the USA (309-698-5611). Please have available product part numbers, serial numbers, and approximate date of installation. In order to assist you, after the product has been placed into service, complete the online product registration section which is accessed via our website www.go4b.com/usa.

PRODUCT OVERVIEW

The Auto-Set™ series RF capacitance point level monitors are used for detecting high, intermediate, or low levels of liquids, powders and free flowing granular solids stored in tanks, bins, silos or other containers.

The Auto-Set series incorporates simple push-button calibration with microprocessor enable/disable switch for total protection of stored values. Once the Auto-Set is calibrated for the application it never has to be re-calibrated. Data is stored in non-volatile memory so it is not affected by power loss.

A four digit LED display shows set values for uncovered, covered and trip settings, allowing simple set-up and adjustment. A set of voltage-free changeover relay contacts are actuated when the level of the material in the container reaches the probe. The unit incorporates a unique power shield which automatically compensates for material build-up around the probe and on the sides of the container, preventing false indication. The solid state electronics are housed in a weatherproof, glass-reinforced nylon enclosure.

The Auto-Set series can be top or side mounted, and are available with 3, 12, 24, 36 and 48 inch 316 solid stainless steel probes. For applications up to 33 feet long (maximum), 304 stainless steel wire is used to extend the probe length. The Auto-Set can be used with container walls up to 14.5 inches thick (see specifications).

The flush probe version (ATS7V0FC-FP) is designed for plug condition monitoring within tight fitting applications. It has a built-in mounting flange, and the probe can be inserted 1-1/4 inches (minimum) into a tank or spouting with container walls up to 3/4 inch thick. For container walls thinner than 3/4 inch, the probe can be inserted farther.

For high temperature and/or high vibration applications, a remote Auto-Set version is available. Contact 4B for more information.

SPECIFICATIONS

Power Supply -	120/240 VAC or 24 VDC (Universal Supply)
Operating Temp. -	-25° F (-32° C) to 160° F (71° C)
Sensitivity -	0.5 Pico Farad
Output -	1 Set Voltage Free Changeover Relay Contacts Rated at 2.5 Amps / 240 VAC
Fail Safe -	Low Level or High Level (Selectable)
Calibration -	Push Button (With or Without Material)
LED Display -	Measured Values (Covered, Uncovered, Trip)
LED Indicator -	Material Detection
Time Delay -	0 to 60 Seconds
Power Shields -	ATS7V0FC ~ 3-7/8 Inch (Container Walls up to 3 Inches Thick) ATS7V0FC-300 ~ 12-1/16 Inch (Container Walls 3 to 11 Inches Thick) ATS7V0FC-400 ~ 15-5/16 Inch (Container Walls 11 to 14.5 Inches Thick) ATS7V0FC-FP ~ 1/4 Inch (Container Walls up to 3/4 Inch Thick)
Probes -	Stainless Steel
Conduit Entry -	3/4 Inch NPT (2)
Enclosure -	Flame Retardant, Glass Reinforced Nylon
Protection -	IP65, NEMA 4
Approvals -	CSA Class II Div 1 Group E, F & G (USA & Canada) ATEX and CE (Versions Available)

DIMENSIONS

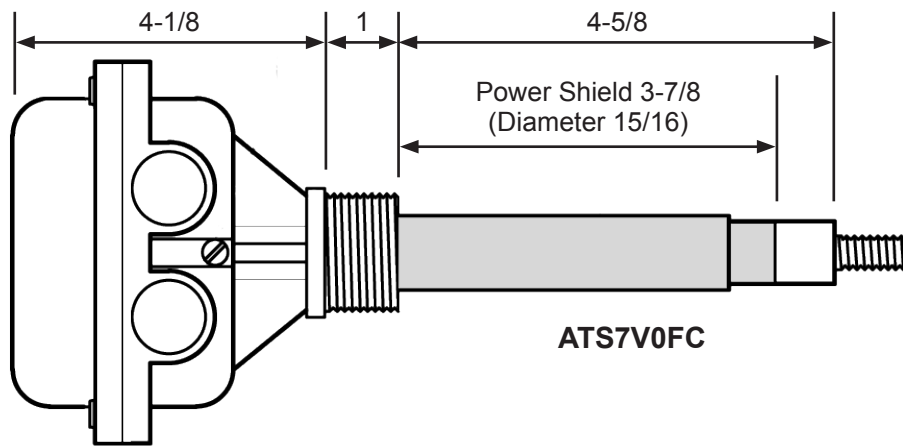

ALL DIMENSIONS
IN INCHES

Dimensions are Shared with the Exceptions of the Power Shields (Show in Grey) and Overall Lengths.

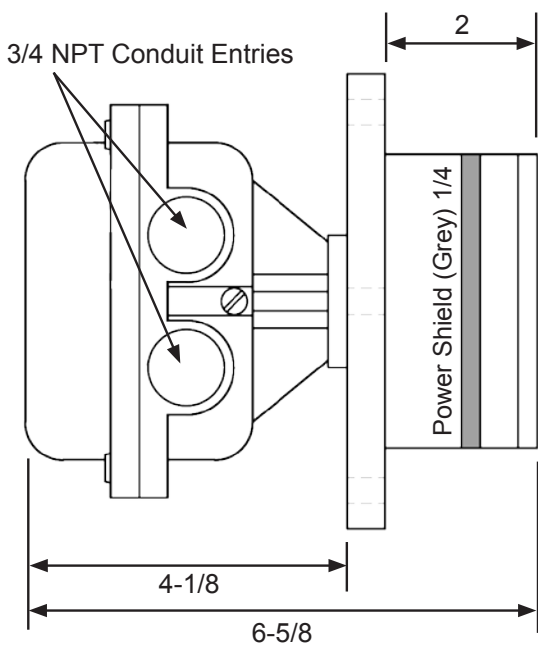
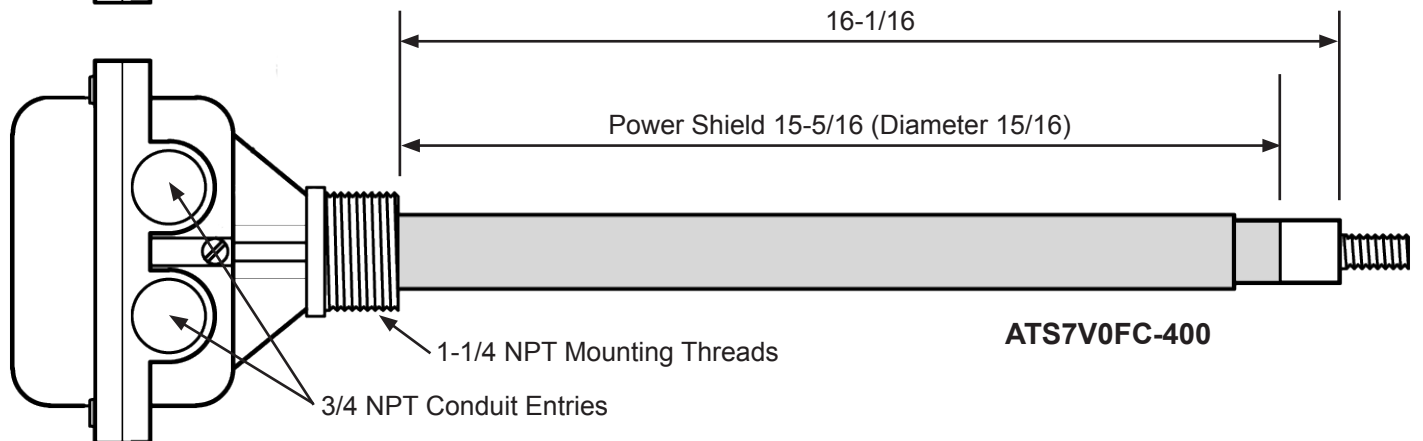
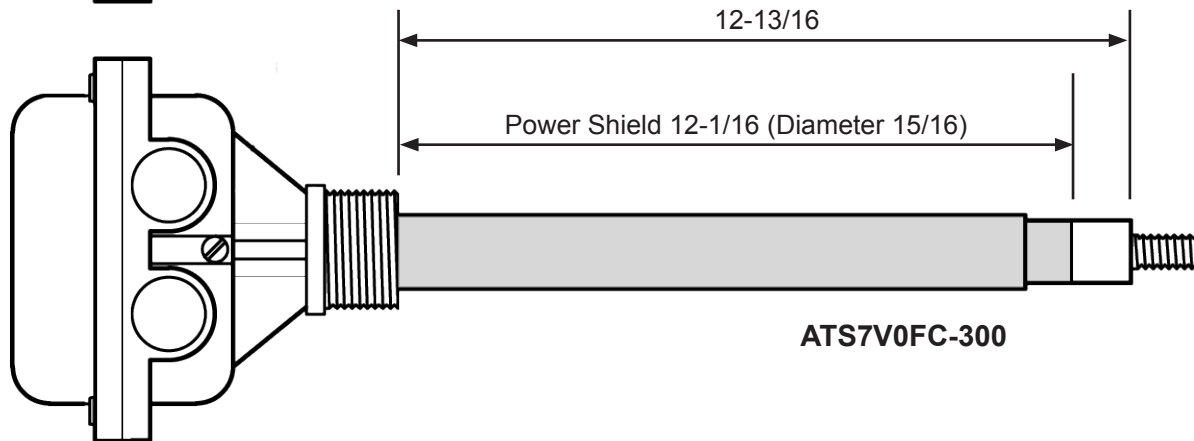

AT57V0FC-FP

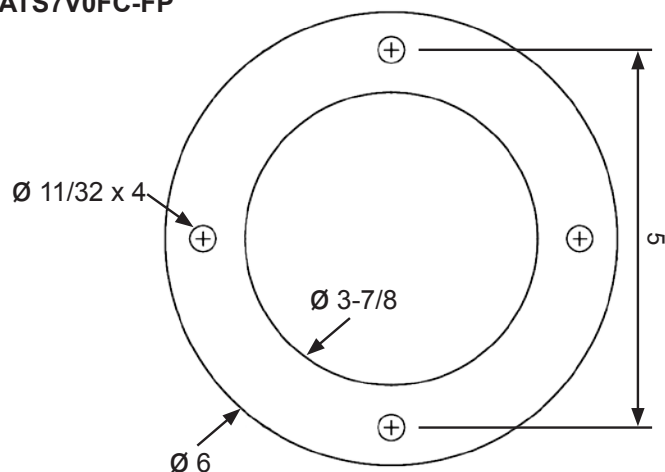

DIMENSIONS

ALL DIMENSIONS
IN INCHES

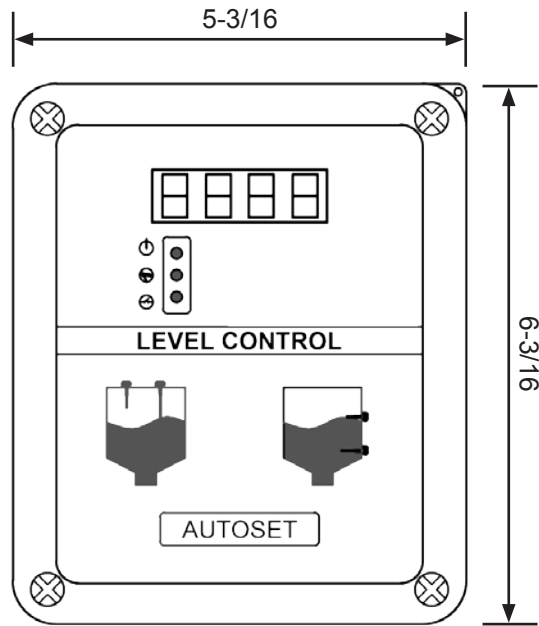

INSTALLATION

A thread locking compound is already applied to the probe fixing stud of the Auto-Set. This will prevent the probe rod from vibrating loose. Once fitted, the compound is fully hardened after 20 minutes.

When mounting all versions of the Auto-Set, care must be taken to ensure that the power shield is properly installed.

ATS7V0FC / ATS7V0FC-300 / ATS7V0FC-400 MODELS -

The power shield is covered with a plastic sleeve with about 5/8 inch of bare metal exposed toward the probe end. A minimum of 1/4 inch of the plastic sleeving must protrude into the vessel (Image A). Mount the unit securely to minimise vibration.

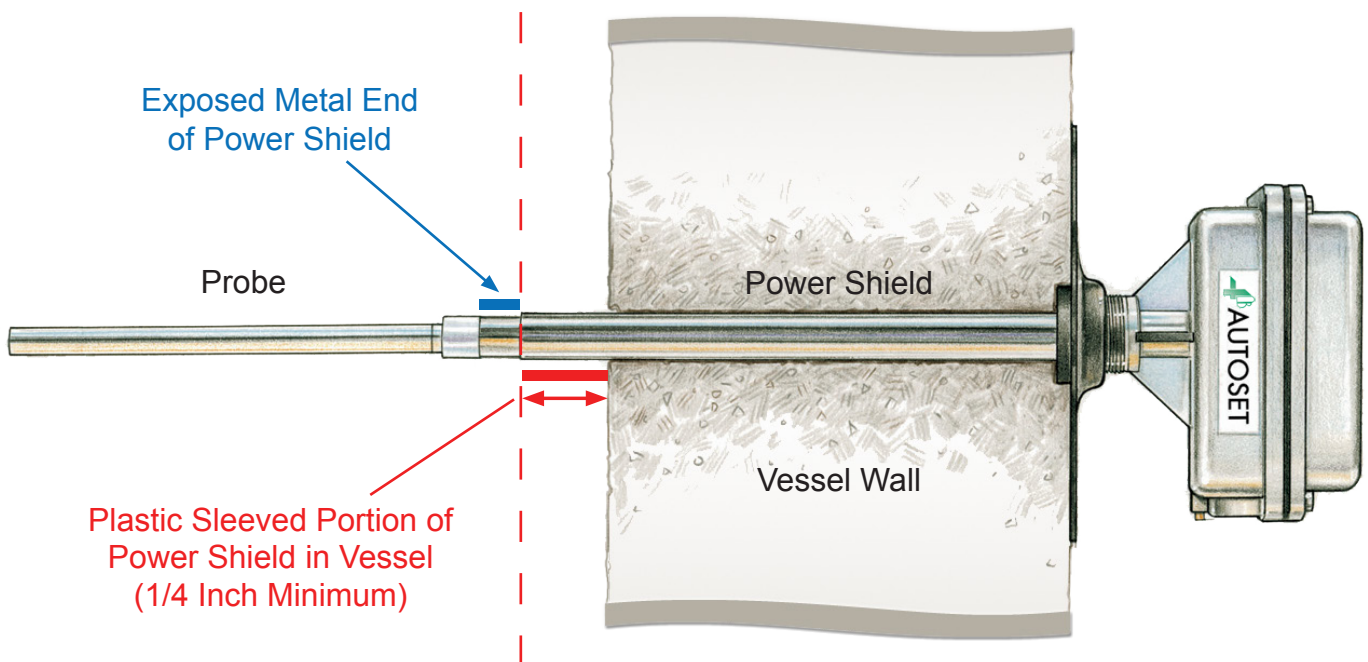

Image A - Power Shield Spacing

ATS7V0FC-FP (FLUSH PROBE) MODEL -

The probe can be inserted 1-1/4 inches (minimum) into the vessel depending on the wall thickness. Both the metal probe and the power shield are integrated into the plastic mounting flange. A minimum of 1/4 inch of the plastic mounting flange must protrude into the vessel, with a maximum wall thickness of 3/4 inch (Image B). Mount the unit securely to minimise vibration.

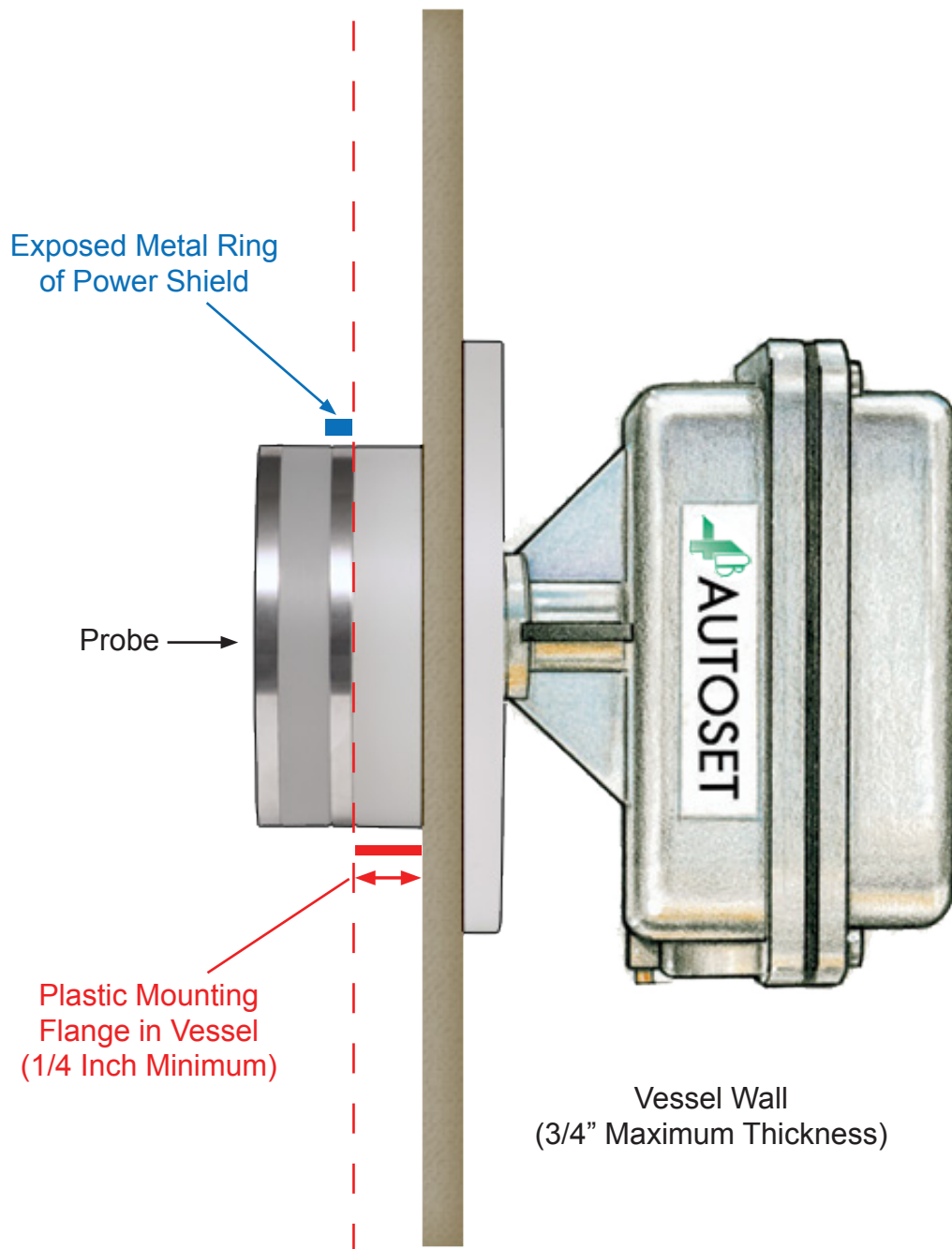

Image B - Flush Probe Power Shield Spacing

! WARNING

Proper spacing of the power shield is vital for correct operation. For questions regarding proper spacing of the power shield to the vessel wall, contact 4B.

NOTE

For high temperature and/or high vibration applications, a remote Auto-Set version is available. Contact 4B for more information.

STANDARD WIRING DIAGRAM

All wiring must be in accordance with local and national electrical codes and should be undertaken by an experienced and qualified electrician.

Always use dust/liquid tight flexible metal conduit with approved fittings to protect the sensor cables. Conduit systems can channel water due to ingress and condensation directly to sensors and sensor connections which over time will adversely affect the performance of the system. As such, the installation of low point conduit drains is recommended for all sensors.

Wire the Auto-Set to the correct power supply voltage as outlined below (Image C), and set the High/Low switch to the required position. The Auto-Set must be grounded using the unit ground screw located on the outside of the housing (Image C). The internal wire terminal is already connected to the terminal ground point from the factory (Image C), do not remove this connection.

On metal bins and silos, the Auto-Set must be grounded to the container. If the bin or silo is non-metallic, the metal flanges or couplings used to mount the Auto-Set should be grounded.

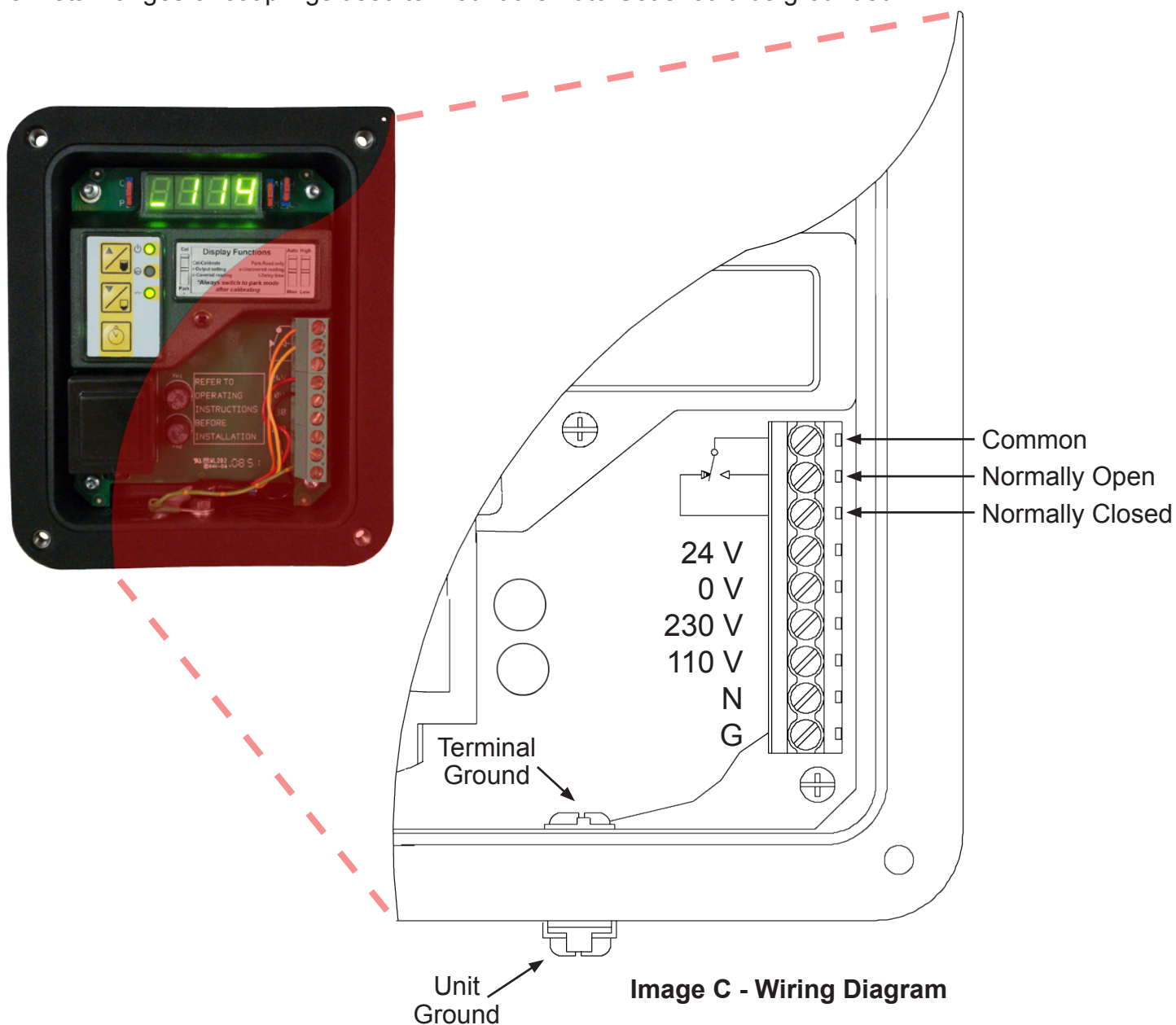

NOTE

The Auto-Set must be grounded using the unit ground screw located on the outside of the housing. The internal wire terminal is already connected to the terminal ground point from the factory, do not remove this connection.

SENSOR OPERATION

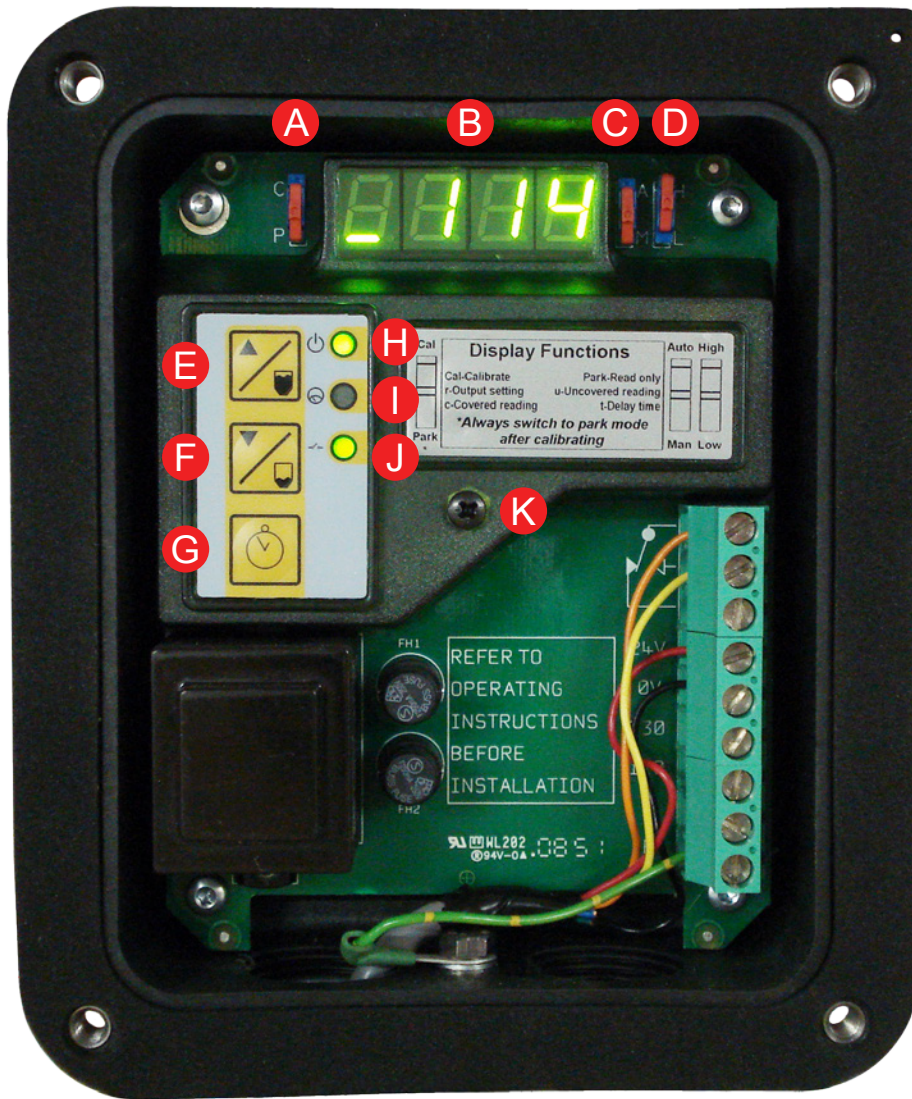

A	Park / Calibrate (SW3)
B	4 Digit LED Display
C	Auto / Manual (SW1)
D	High / Low (SW5)
E	Probe Covered / Raise
F	Probe Un-Covered / Lower
G	Timer
H	Power On LED
I	Calibrating LED
J	Output LED
K	Test Screw

Image D - Inside View

FAIL SAFE SETTING -

The “High/Low” switch (D - Image D), sets the fail safe mode. In the “High” position, the relay is energized without material present. In the “Low” position, the relay is energized with material present. Normally, the “High” position is used for high level probes and the “Low” position for low level probes. Intermediate probe settings depend upon individual requirements.

PARK MODE -

In normal operation, the LED display shows a value representing the capacitance measured by the probe at the time.

 Pressing and holding the “Probe Covered / Raise” button (E - Image D) will cause the display to show CXXX followed by RXXX.

 Pressing and holding the “Probe Un-Covered / Lower” button (F - Image D) will cause the display to show UXXX followed by RXXX.

CXXX is the probe covered value measured during calibration, UXXX is the uncovered value and RXXX is the relay operating point which the Auto-Set calculates and is half way between the two measured values.

NOTE

In park mode, settings are “View Only” and cannot be altered.

CAL MODE (AUTO/MAN SWITCH SET TO AUTO) -



In this mode, pressing and holding the “Probe Covered / Raise” button (E - Image D) with the probe covered, will cause the unit to measure and display the covered value, and recalibrate the relay operating point if necessary.



Pressing and holding the “Probe Un-Covered / Lower” button (F - Image D) with the probe uncovered, will cause the unit to measure and display the uncovered value, again recalibrating the relay operating point if necessary.

CAL MODE (AUTO/MAN SWITCH SET TO MAN) -



In this mode, pressing and holding the “Probe Covered / Raise” button (E - Image D) will cause the display to momentarily display the present relay operating point and then to increment the setting slowly and then rapidly to set a higher operating point.



Pressing and holding the “Probe Un-Covered / Lower” button (F - Image D) will cause the display to momentarily show the current relay operating point, and then decrement the setting, slowly and then rapidly.

Once adjusted in manual mode, any previous settings will be lost. The CXXX reading will be 1 above the relay operating point and the UXXX reading 1 below.

NOTE

Always return to “Park” after calibration.



Image E - Top Cover View

SENSOR CALIBRATION

The Auto-Set can be calibrated automatically, manually or by a combination of the two methods. Usually, automatic calibration is the simplest method, particularly when the vessel can be filled to cover the probe.

Manual calibration is useful when a number of probes in similar applications need to be set. Once the correct calibration has been determined and noted, on one system, the remainder can be set to the same setting.

AUTOMATIC CALIBRATION (MATERIAL AVAILABLE) -

1. Set Park/Cal switch (A - Image D) to Cal and Auto/Man switch (C - Image D) to Auto. The Cal LED will flash.



2. Ensure that the probe is uncovered and press and hold the “Probe Un-Covered / Lower” button (F - Image D) button. The display will show UXXX followed by RXXX.



3. Fill the vessel sufficiently to cover the probe and then press the “Probe Covered / Raise” button (E - Image D) button. Display will show CXXX followed by RXXX.

4. Return the Park/Cal switch (A - Image D) to park. The unit is now calibrated. UXXX and CXXX values can be viewed but not altered by pressing the “Probe Un-Covered / Lower” and “Probe Covered / Raise” buttons together.

SEMI-AUTOMATIC CALIBRATION (MATERIAL NOT AVAILABLE) -

5. Follow steps 1 & 2 above.



6. Set Cal/Park switch (A - Image D) to Park and press the “Probe Un-Covered / Lower” button (F - Image D) button. Note the UXXX reading but ignore the RXXX reading. Return the Cal/Park switch (A - Image D) to Cal and set the Auto/Man switch (C - Image D) to Man.

7. From Table A below, select the nearest material type to be detected for your application and add the value to the UXXX reading determined in step 6.



8. Press the “Probe Covered / Raise” button (E - Image D) button to raise the reading and the “Probe Un-Covered / Lower” button (F - Image D) to lower the reading to achieve the calculated setting from step 7.



9. Return the Cal/Park switch (A - Image D) to Park and press and hold the “Probe Covered / Raise” button (E - Image D) to confirm that the relay operating point RXXX is correctly set. The UXXX and CXXX settings will be one below and one above the readings.

Table A - Typical Settings

Material Type	Increment
Light	+15
Medium	+30
Heavy	+60 or Greater

TIME DELAY -

The Auto-Set has an adjustable delay from 0 to 60 seconds, the timer operating on both material arriving and leaving.

To set the time delay, proceed as follows:

10. Set the Cal/Park switch (A - Image D) to Cal.



11. Press and hold the timer button (G - Image D), the display will show T000 (zero delay). To set a time delay, continue to hold the timer button and the display will start to increase by 1 second increments (maximum delay is 60 seconds). When the required delay time is shown, release the timer button. To reset the delay, press and hold the timer button again to restart the entire process from T000 (zero delay).



12. Return the Cal/Park switch (A - Image D) to Park and press the timer button (G - Image D) to confirm the timer setting.

13. The timer can be altered to a longer or shorter delay by repeating the entire procedure from steps 10 to 12.

NOTE

For questions regarding non-standard Auto-Set probe lengths or diameters, contact 4B.

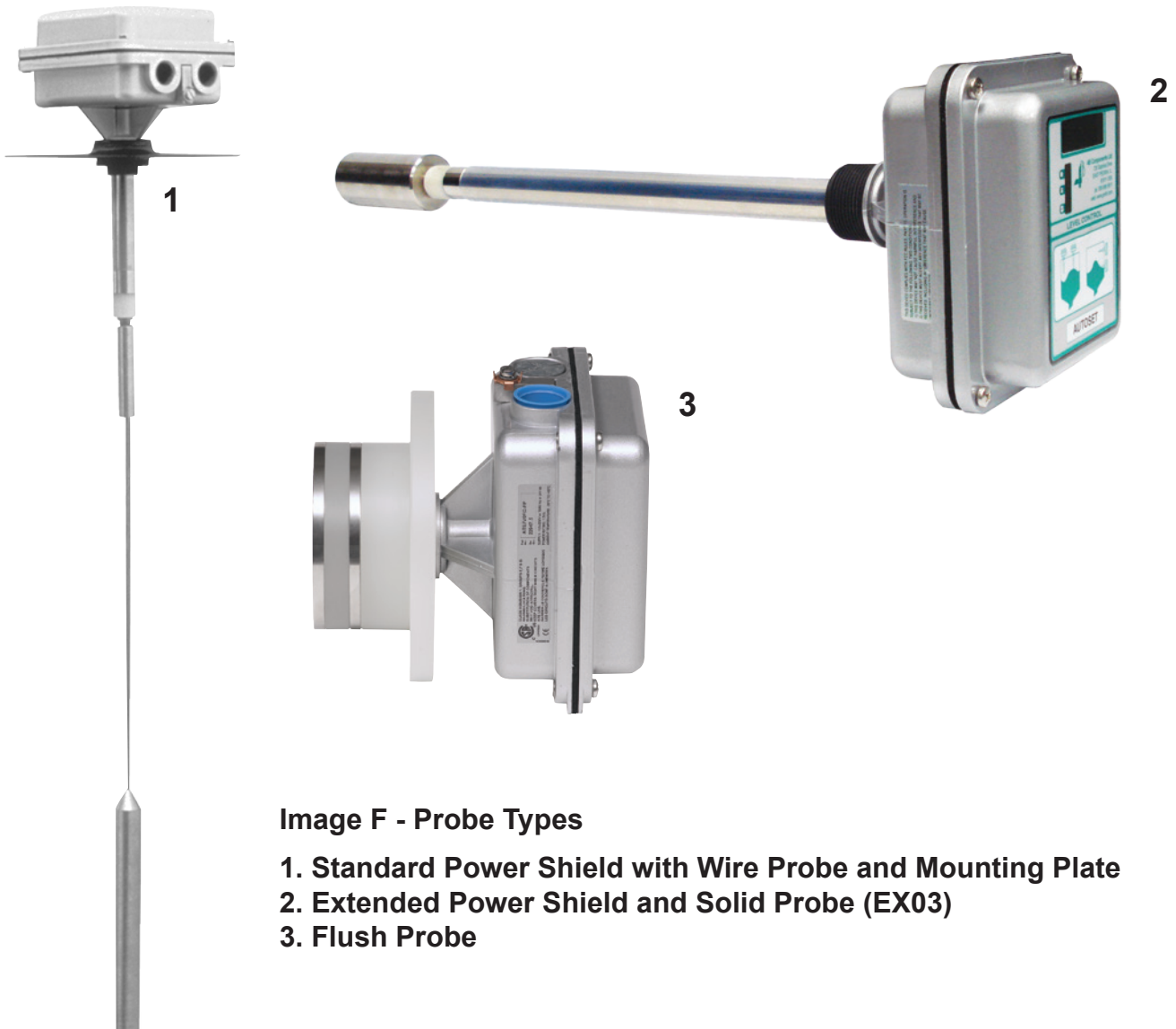

POWER SHIELD OVERVIEW

The Auto-Set detects material by radiating a high frequency (RF) signal from the probe. The advanced electronics of the Auto-Set use this signal to measure the capacitance inside the vessel with respect to ground and thus indicate when material has reached the Auto-Set probe.

The power shield creates a barrier and enables the unit to ignore a certain amount of material built up on the probe, helping to prevent false readings. The Auto-Set is available in four power shield lengths, and can be used with walls that are up to 14.5 inches thick. Installation through thick concrete silos only requires a 1 inch diameter hole for probe insertion.

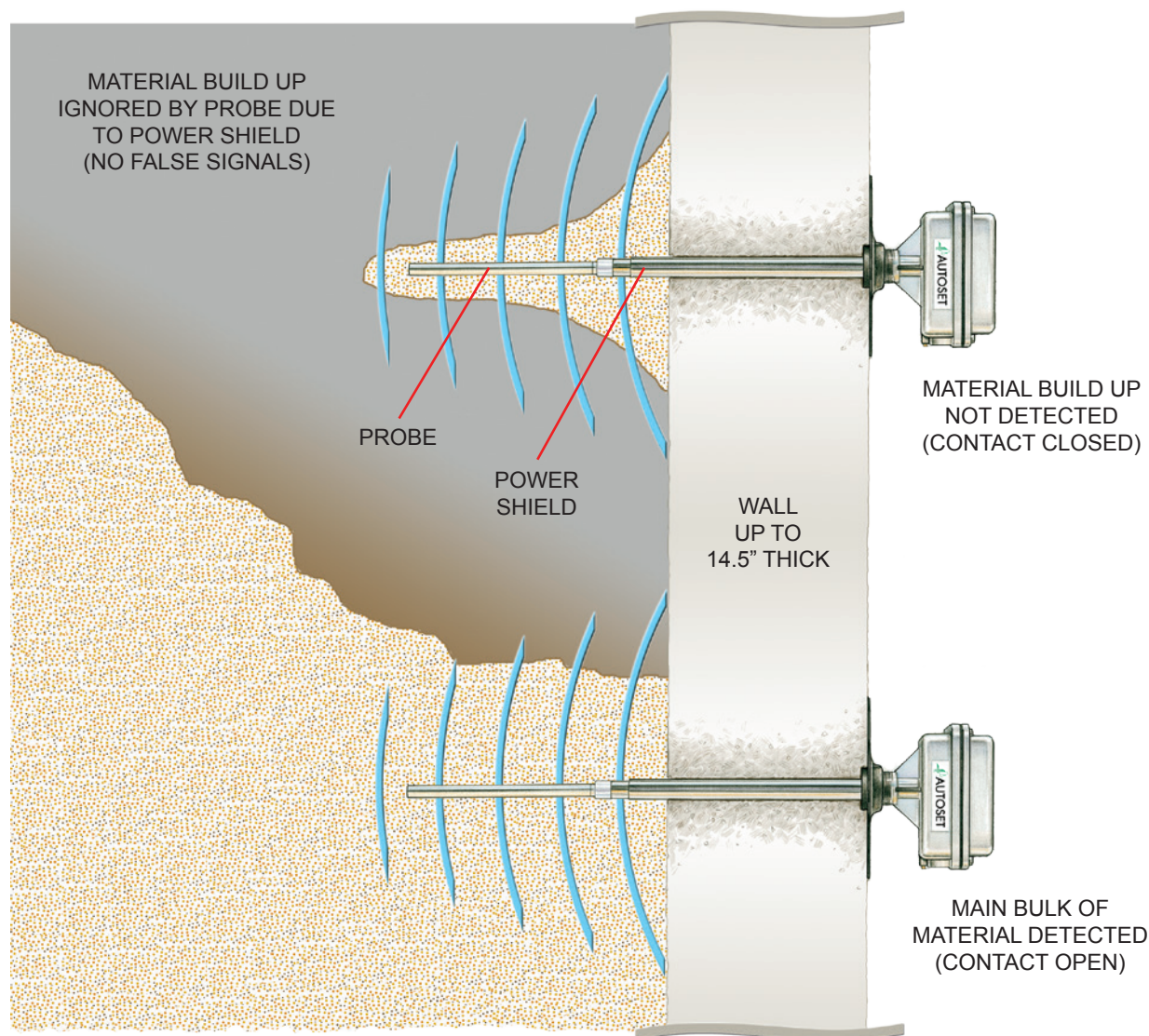

NOTE

The actual amount of material build up that the Auto-Set is able to ignore is dependant upon several factors, including the density of the material, the moisture content of the material and the type/style of the vessel.

TESTING AND COMMISSIONING

1. Check that the unit is correctly installed (see standard wiring diagram).
2. After going through the sensor calibration steps, the green LED should be “ON”.
3. Introduce material to the Auto-Set. If material is not available, touch the test screw (K - Image D). If calibrated correctly, the Auto-Set will activate when material has been detected or the test screw has been touched. Machinery shut down will depend on your specific monitoring setup. 4B recommends an instant shutdown when maximum fill level or a plug condition has been detected.

NOTE

Do not tighten or loosen the test screw. Touching it with your finger will activate the probe.

WARNING

If the system does not immediately shutdown as expected or alarm as required, then remove the machine from service until the problem has been diagnosed and corrected.

TROUBLESHOOTING GUIDE

FAULT	REMEDY
Readings fluctuate when the weather changes.	Ground the Auto-set to the bin using the unit ground connection (Image C).
Relays operate backwards.	Verify that the “High/Low” switch is in the correct position (D - Image D).
Relay activates sporadically.	Set the timer delay to 1 or 2 seconds to ignore sporadic material issues.

PARTS & ACCESSORIES

STAINLESS STEEL PROBES/WIRE

The Auto-Set™ is available with 316 solid stainless steel probes. For applications up to 33 feet long (maximum), 304 stainless steel wire is used to extend the probe length.

Probe	Length	Diameter
EX03	3-3/8"	1-1/2"
EX12	8"	5/8"
EX24	20"	5/8"
EX36	32"	5/8"
EX48 ¹	44"	5/8"
WPA ²	3"	5/8"
WPW ³	8"	1"

- 1 - EX48 has Male & Female Threaded Ends for Adding Extensions
- 2 - Wire Probe Adaptor (WPA)
- 3 - Wire Probe Weight (WPW)

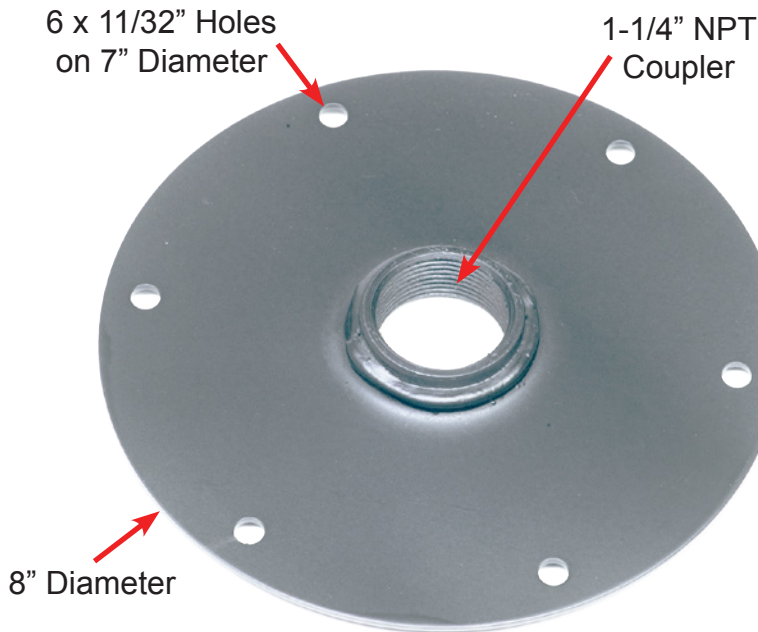

MOUNTING PLATE (SMP)

The SMP is a zinc plated steel mounting plate for installing the Auto-Set™. A stainless steel version is also available.

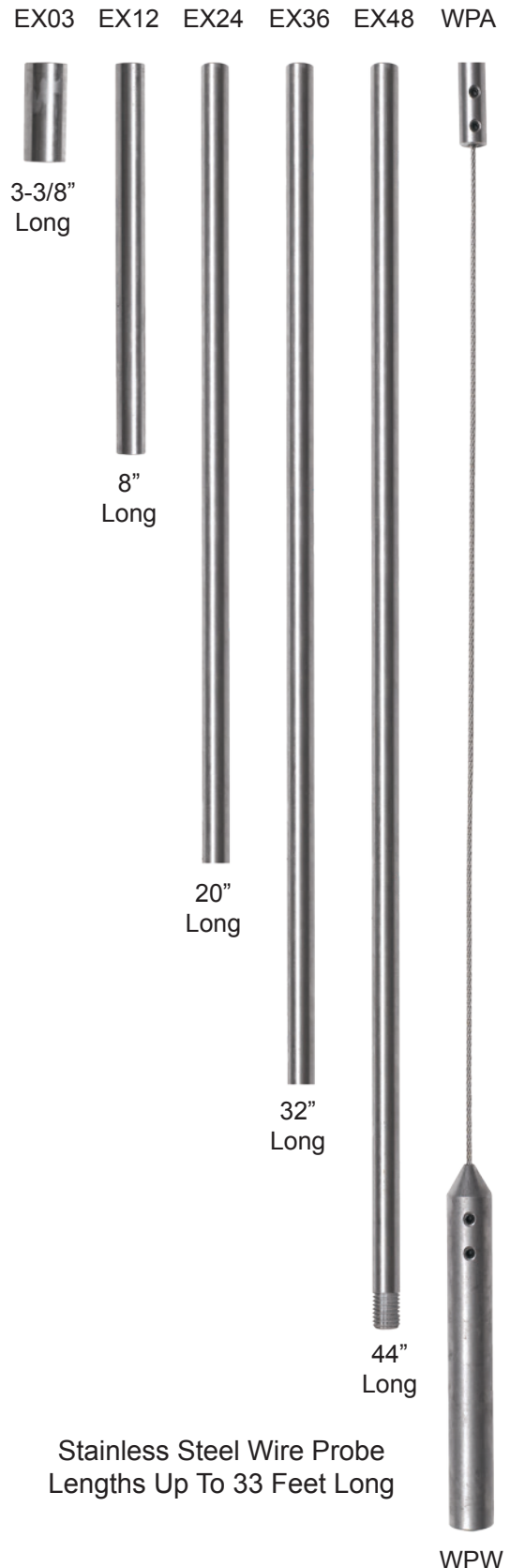

Stainless Steel Wire Probe Lengths Up To 33 Feet Long

NOTE

These parts and accessories are not used with Auto-Set flush probe (ATS7V0FC-FP).

PRODUCT WARRANTY

1. EXCLUSIVE WRITTEN LIMITED WARRANTY

ALL PRODUCTS SOLD ARE WARRANTED BY THE COMPANY 4B COMPONENTS LIMITED AND 4B BRAIME COMPONENTS LIMITED HEREIN AFTER REFERRED TO AS 4B TO THE ORIGINAL PURCHASER AGAINST DEFECTS IN WORKMANSHIP OR MATERIALS UNDER NORMAL USE FOR ONE (1) YEAR AFTER DATE OF PURCHASE FROM 4B. ANY PRODUCT DETERMINED BY 4B AT ITS SOLE DISCRETION TO BE DEFECTIVE IN MATERIAL OR WORKMANSHIP AND RETURNED TO A 4B BRANCH OR AUTHORIZED SERVICE LOCATION, AS 4B DESIGNATES, SHIPPING COSTS PREPAID, WILL BE, AS THE EXCLUSIVE REMEDY, REPAIRED OR REPLACED AT 4B'S OPTION.

2. DISCLAIMER OF IMPLIED WARRANTY

NO WARRANTY OR AFFIRMATION OF FACT, EXPRESSED OR IMPLIED, OTHER THAN AS SET FORTH IN THE EXCLUSIVE WRITTEN LIMITED WARRANTY STATEMENT ABOVE IS MADE OR AUTHORIZED BY 4B. 4B SPECIFICALLY DISCLAIMS ANY LIABILITY FOR PRODUCT DEFECT CLAIMS THAT ARE DUE TO PRODUCT MISUSE, ABUSE OR MISAPPLICATIONS, AS AUTHORIZED BY LAW, 4B SPECIFICALLY DISCLAIMS ALL WARRANTIES THAT THE PRODUCT IS FIT OR MERCHANTABLE FOR A PARTICULAR PURPOSE.

3. NO WARRANTY "BY SAMPLE OR EXAMPLE"

ALTHOUGH 4B HAS USED REASONABLE EFFORTS TO ACCURATELY ILLUSTRATE AND DESCRIBE THE PRODUCTS IN ITS CATALOGS, LITERATURE, AND WEBSITES, SUCH ILLUSTRATIONS AND DESCRIPTIONS ARE FOR THE SOLE PURPOSE OF PRODUCT IDENTIFICATION AND DO NOT EXPRESS OR IMPLY A WARRANTY AFFIRMATION OF FACT, OF ANY KIND OR A WARRANTY OR AFFIRMATION OF FACT THAT THE PRODUCTS WILL CONFORM TO THEIR RESPECTIVE ILLUSTRATIONS OR DESCRIPTIONS. 4B EXPRESSLY DISCLAIMS ANY WARRANTY OR AFFIRMATION OF FACT, EXPRESSED OR IMPLIED, OTHER THAN AS SET FORTH IN THE EXCLUSIVE WRITTEN LIMITED WARRANTY STATEMENT ABOVE, INCLUDING, WITHOUT LIMITATION, THE IMPLIED WARRANTIES OF MERCHANTABILITY AND FITNESS FOR A PARTICULAR PURPOSE.

4. LIMITATION OF DAMAGES

ANY LIABILITY FOR CONSEQUENTIAL, INCIDENTAL, SPECIAL, EXEMPLARY, OR PUNITIVE DAMAGES, OR FOR LOSS OF PROFIT WHETHER DIRECT OR INDIRECT, IS EXPRESSLY DISCLAIMED.

With subsidiaries in North America, Europe, Asia, Africa and Australia along with a worldwide network of distributors, 4B can provide practical solutions for all your applications no matter the location.



4B BRAIME COMPONENTS LTD.

Hunslet Road
Leeds
LS10 1JZ
United Kingdom
Tel: +44 (0) 113 246 1800
Fax: +44 (0) 113 243 5021

4B DEUTSCHLAND

9 Route de Corbie
Lamotte Warfusée
F-80800
France
Tel: +49 (0) 700 2242 4091
Fax: +49 (0) 700 2242 3733

4B ASIA PACIFIC

Build No. 899/1 Moo 20
Soi Chongsiri, Bangplee-Tam Ru Road,
Tanbon Bangpleeeyai, Amphur Bangplee,
Samutprakarn 10540
Thailand
Tel: +66 (0) 2 173-4339
Fax: +66 (0) 2 173-4338

4B COMPONENTS LTD.

625 Erie Avenue
Morton, IL 61550
USA
Tel: 309-698-5611
Fax: 309-698-5615

4B FRANCE

9 Route de Corbie
80800 Lamotte Warfusée
France
Tel: +33 (0) 3 22 42 32 26
Fax: +33 (0) 3 22 42 37 33

4B AFRICA

14 Newport Business Park
Mica Drive, Kya Sand
2163 Johannesburg
South Africa
Tel: +27 (0) 11 708 6114
Fax: +27 (0) 11 708 1654

4B AUSTRALIA

Unit 1/18 Overlord Place
Acacia Ridge
Queensland 4110
Australia
Tel: +61 (0) 7 3711 2565
Fax: +61 (0) 7 3711 2574

www.go4b.com