



# WDA Sensor

BELT ALIGNMENT / MOTION &  
BROKEN / SLACK CHAIN MONITOR

  
C US  
APPROVED  
Class II Div. 1



**INSTALLATION INSTRUCTIONS**

# OPERATION MANUAL

Part No. WDA3V34C

[www.go4b.com/usa](http://www.go4b.com/usa)

**! WARNING**



**Moving parts can crush and cut.**

**Lockout power before removing guard or servicing.**

**Do NOT operate with guard removed**

**! DANGER**

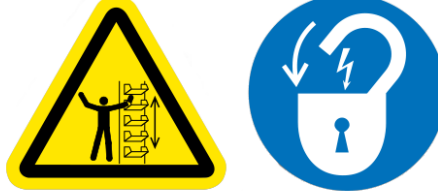

**Exposed buckets and moving parts will cause severe injury or death.**

**Lockout power before removing cover or inspection door.**

**! DANGER**



**Exposed moving parts will cause severe injury or death.**

**Lockout power before removing cover or inspection door.**

**! DANGER**



**Exposed rotating parts will cause severe injury or death.**

**Lockout power before removing cover or inspection door.**

# TABLE OF CONTENTS

CUSTOMER SAFETY RESPONSIBILITIES	Page 4 - 5
PRODUCT OVERVIEW	Page 6
SPECIFICATIONS	Page 6
DIMENSIONS	Page 7
INSTALLATION - BUCKET ELEVATOR	Page 8
BUCKET ELEVATOR PLACEMENT DIAGRAMS	Page 9 - 12
INSTALLATION - CONVEYORS	Page 13 - 14
STANDARD WIRING DIAGRAMS	Page 15 - 16
TESTING & COMMISSIONING	Page 17
SENSOR CALIBRATION	Page 17
TROUBLESHOOTING GUIDE	Page 17
PARTS & ACCESSORIES	Page 18
PRODUCT WARRANTY	Page 19

Dear 4B Customer:

Congratulations on your purchase. 4B appreciates your business and is pleased you have chosen our products to meet your needs.

Please read in its entirety and understand the literature accompanying the product before you place the product into service. Please read the safety precautions carefully before operating the product. With each product you purchase from 4B, there are some basic but important safety considerations you must follow to be sure your purchase is permitted to perform its design function and operate properly and safely, giving you many years of reliable service. Please read and understand the Customer Safety Responsibilities listed below. Failure to follow this safety directive and the Operation Manuals and other material furnished or referenced, may result in serious injury or death.

### ***SAFETY NOTICE TO OUR CUSTOMERS***

- A. In order to maximize efficiency and safety, selecting the right equipment for each operation is vital. The proper installation of the equipment, and regular maintenance and inspection is equally important in continuing the proper operation and safety of the product. The proper installation and maintenance of all our products is the responsibility of the user unless you have asked 4B to perform these tasks.
- B. All installation and wiring must be in accordance with Local and National Electrical Codes and other standards applicable to your industry. (Please see the article “Hazard Monitoring Equipment Selection, Installation and Maintenance” at [www.go4b.com](http://www.go4b.com).) The installation of the wiring should be undertaken by an experienced and qualified professional electrician. Failure to correctly wire any product and/or machinery can result in the product or machine failing to operate as intended, and can defeat its design function.
- C. Periodic inspection by a qualified person will help assure your 4B product is performing properly. 4B recommends a documented inspection at least annually and more frequently under high use conditions.
- D. Please see the last page of this manual for all warranty information regarding this product.

### ***CUSTOMER SAFETY RESPONSIBILITIES***

#### **1. READ ALL LITERATURE PROVIDED WITH YOUR PRODUCT**

Please read all user, instruction and safety manuals to ensure that you understand your product operation and are able to safely and effectively use this product.

#### **2. YOU BEST UNDERSTAND YOUR NEEDS**

Every customer and operation is unique, and only you best know the specific needs and capabilities of your operation. Please call the 24-hour hotline at 309-698-5611 for assistance with any questions about the performance of products purchased from 4B. 4B is happy to discuss product performance with you at any time.

### **3. SELECT A QUALIFIED AND COMPETENT INSTALLER**

Correct installation of the product is important for safety and performance. If you have not asked 4B to perform the installation of the unit on your behalf, it is critical for the safety of your operation and those who may perform work on your operation that you select a qualified and competent electrical installer to undertake the installation. The product must be installed properly to perform its designed functions. The installer should be qualified, trained, and competent to perform the installation in accordance with Local and National Electrical Codes, all relevant OSHA Regulations, as well as any of your own standards and preventive maintenance requirements, and other product installation information supplied with the product. You should be prepared to provide the installer with all necessary installation information to assist in the installation.

### **4. ESTABLISH AND FOLLOW A REGULAR MAINTENANCE AND INSPECTION SCHEDULE FOR YOUR 4B PRODUCTS**

You should develop a proper maintenance and inspection program to confirm that your system is in good working order at all times. You will be in the best position to determine the appropriate frequency for inspection. Many different factors known to the user will assist you in deciding the frequency of inspection. These factors may include but are not limited to weather conditions; construction work at the facility; hours of operation; animal or insect infestation; and the real-world experience of knowing how your employees perform their jobs. The personnel or person you select to install, operate, maintain, inspect or perform any work whatsoever, should be trained and qualified to perform these important functions. Complete and accurate records of the maintenance and inspection process should be created and retained by you at all times.

### **5. RETAIN AND REFER TO THE OPERATION MANUAL FOR 4B'S SUGGESTED MAINTENANCE AND INSPECTION RECOMMENDATIONS**

As all operations are different, please understand that your specific operation may require additional adjustments in the maintenance and inspection process essential to permit the monitoring device to perform its intended function. Retain the Operation Manual and other important maintenance and service documents provided by 4B and have them readily available for people servicing your 4B equipment. Should you have any questions, please call the free 24-hour hotline number (309-698-5611).

### **6. SERVICE REQUEST**

If you have questions or comments about the operation of your unit or require the unit to be serviced please contact the 4B location who supplied the product or send your request via fax (309-698-5615) or call us via our 24-hour hotline number in the USA (309-698-5611). Please have available product part numbers, serial numbers, and approximate date of installation. In order to assist you, after the product has been placed into service, complete the online product registration section which is accessed via our website [www.go4b.com/usa](http://www.go4b.com/usa).

## OVERVIEW

The 4B WDA sensor is designed to detect moving ferrous (magnetic) material passing within its sensing range, and is used in conjunction with a speed relay, PLC or with 4B's Watchdog™ Elite and A400 Elite control units. The sensor will not detect non-ferrous material such as plastic, rubber, stainless steel or aluminium.

The WDA can detect ferrous steel elevator buckets from the side of the elevator leg, or through the elevator belt from the back of the leg. For plastic elevator buckets, the steel elevator bolts used to attach the buckets can be targeted by installing the WDA on the back of the leg.

A more specialized use for the WDA switch is as a broken/slack chain detector on drag chain conveyors, or as a non-contact speed switch for screw conveyors.

A flashing LED on the end of the sensor indicates a target has been detected. A potentiometer control screw, located below the LED, allows the target sensing range to be adjusted from 1 to 3 inches. Two output signals are provided: one signal is a pulse output, representing each object detected: the second signal is a continuous output when moving objects are detected (see wiring diagram).

## SPECIFICATIONS

Voltage -	12 to 24 VDC $\pm$ 10%
Supply Current -	65 mA
LED Indicator -	Green (Flashing) - Target Detected Green (Off) - No Target Detected
Outputs (Max) -	1. 100 mA Sink 2. 50 mA Source
Detection Range -	Adjustable: 1 - 3 Inches (25 - 75 mm) for 1 Inch Diameter Ferrous Target
Detection Rate -	20 - 2,000 PPM (Pulses Per Minute)
Cable -	9 ft. Long - 6 Conductor
Conduit Entry -	1/2 Inch NPT
Temperature Rating -	-4° F to 122° F (-20° C to 50° C)
Protection -	IP66
Approvals -	CSA Class II Div. 1 Groups E, F, & G (USA and Canada) CE, ATEX & IECEx Versions Available (Europe)

- Specifications for part # WDA3V34C, high temperature version also available (HTAS1V34)

## NOTE

The WDA3V34C contains a non-repairable 160 mA fuse and two thermal fuses set at 164°F (73°C). Should the sensor reach the set temperature or higher, one or both of the thermal fuses may fail. The expected maximum ambient temperature of the sensor is 122°F (50°C).

# DIMENSIONS

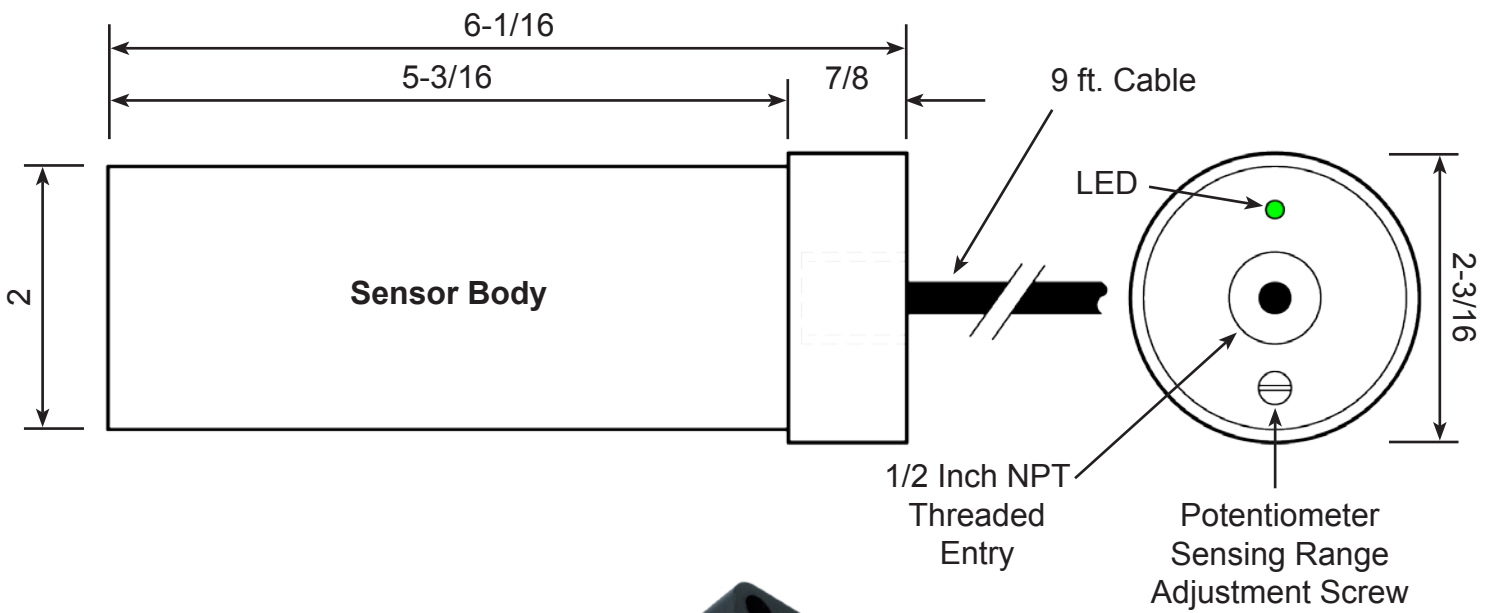
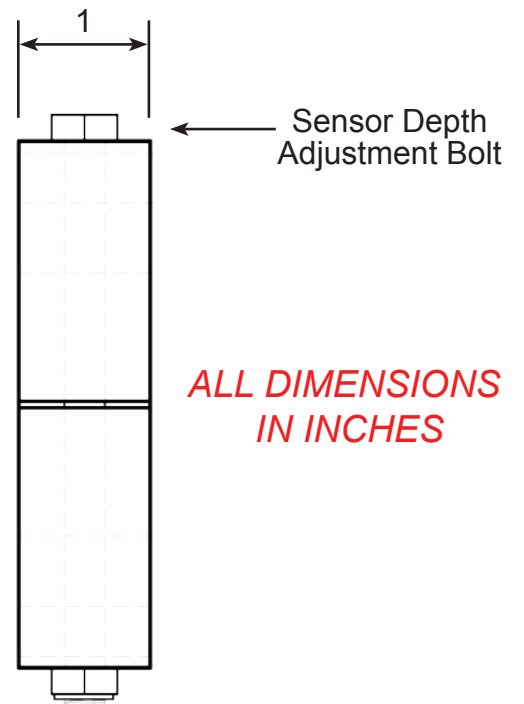
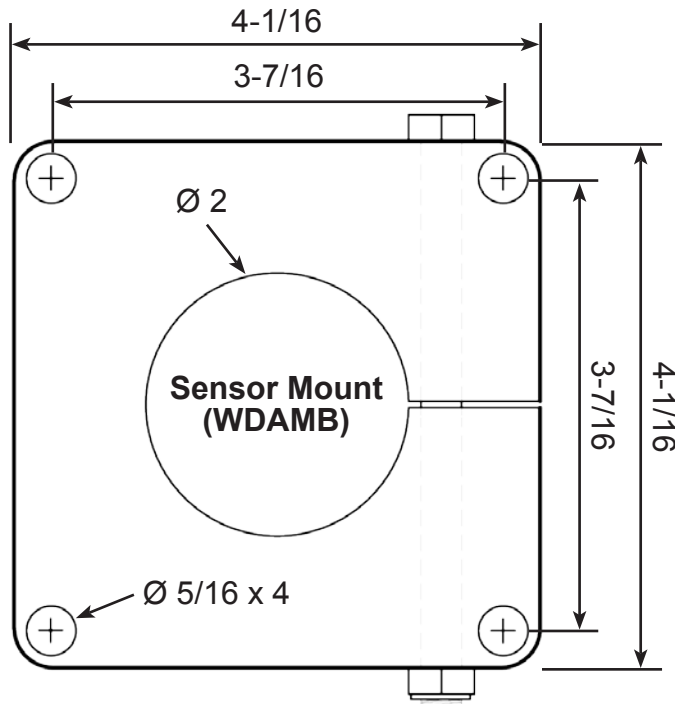

WDA3V34C

## WARNING

- Rotating machinery can cause serious injury or death
- Always lockout and tagout the machine prior to installation

## INSTALLATION - BUCKET ELEVATOR

Sensors are placed in pairs at the head and boot on the up side of the elevator leg (figure 1). Refer to the *BUCKET ELEVATOR PLACEMENT DIAGRAMS* section regarding proper sensor positioning for your application. Sensor installation will vary depending on the type of elevator bucket (metal or plastic).

Once the proper placement has been identified, cut a 2-1/4 inch (57 mm) diameter hole in the elevator leg housing for each sensor.

The WDA sensor can be mounted using one of the following three methods -

1. Drill and tap the machine casing for 5/16 inch threaded bolts. Make sure that the bolts used to secure the sensor mounting bracket are short enough that they do not interfere with the operation of the machine.
2. Use threaded rivet nuts for 5/16 inch threads. The length of the rivet nut will depend on the thickness of the machine's casing. Make sure that the bolts used to secure the sensor mounting bracket are short enough that they do not interfere with the operation of the machine.
3. CD weld 5/16 inch threaded welding studs to the machine casing.

To drill the four 5/16 inch bolt holes for the sensor mounting bracket, use the supplied paper template from the sensor manual or use the bracket itself, by centering on the existing 2-1/4 inch (57 mm) hole.

For side mounting of steel buckets (Option 1), make sure that the belt is centered on the pulley and install a sensor on each side of the trunking, with the sensor centered on the edge of the elevators bucket at a distance of no more than 2 inches (50 mm) from the buckets (figure 3), or with the outer edge of the sensor in line with the tips of buckets with very close vertical spacing at a distance of no more than 1-1/2 inches (38 mm) from the buckets (figure 5). Set the sensor so that it does not have to work at maximum sensitivity. Always ensure that in the worst case of elevator misalignment, the sensors will not be damaged within the elevator.

For rear mounting of plastic buckets with steel bolt heads (Option 2), make sure that the belt is centered on the pulley and install a sensor on either side of the rear of the trunking. The sensor should be centered on the outside edge of the outermost bucket bolts and protrude slightly through the trunking around 1-1/2 inch (25.4 mm) from the bolt head (figure 6).

The sensor depth within the elevator leg can be adjusted by loosening the adjustment bolt on the mounting bracket, sliding the sensor to the required depth and retightening the bolt.

## NOTE

If using stainless steel elevator buckets and bolts (non-ferrous), use PTFE coated steel fender washers (ferrous) between the belt and bucket. Mount WDA sensor on the back side of the leg to target the ferrous bolts / washers (See Figure 6 - Plastic Bucket Installation).



# BUCKET ELEVATOR PLACEMENT DIAGRAMS

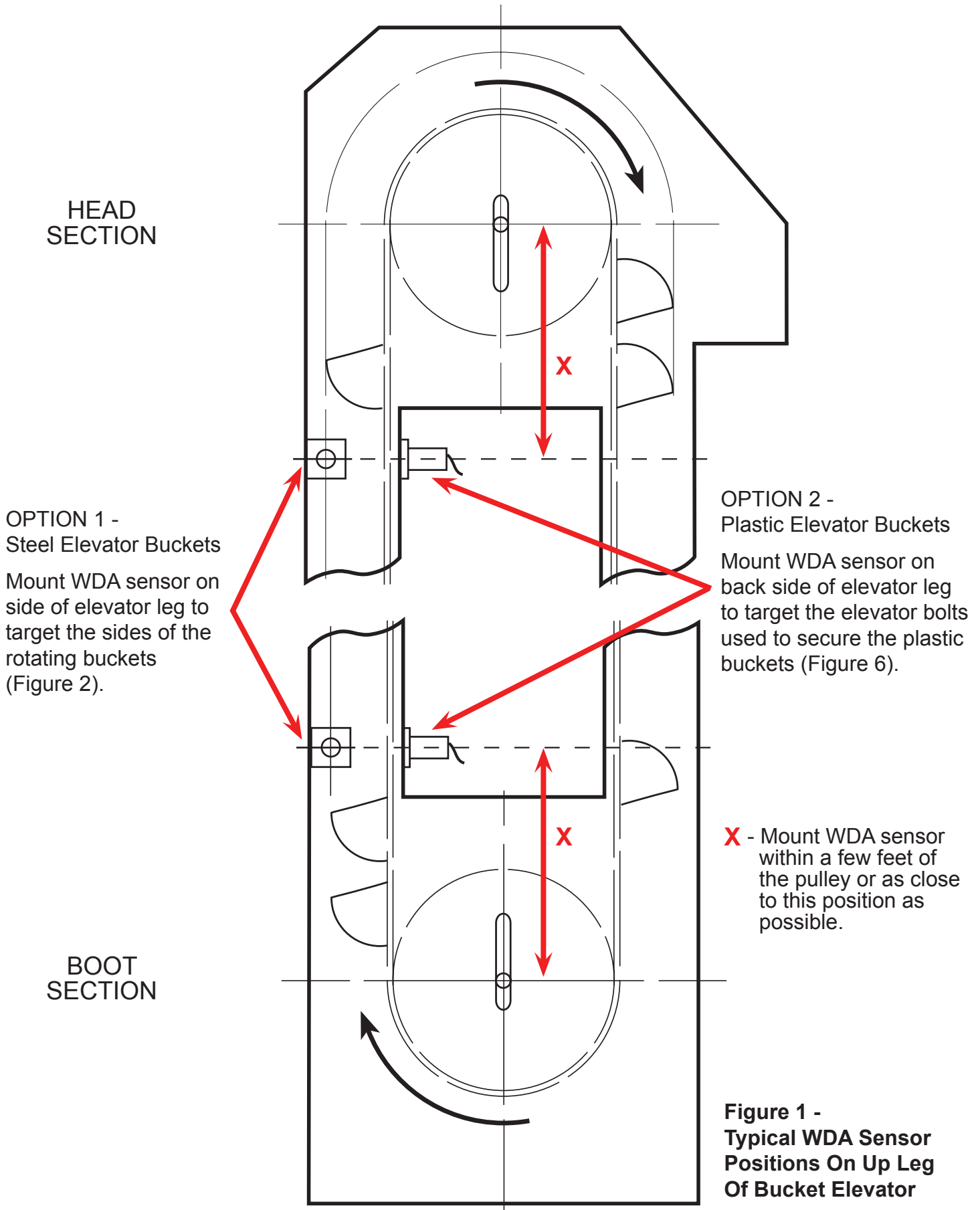

## NOTE

For bucket elevator installations, WDA sensors are designed to work in pairs. One pair mounted on the head of the elevator leg and another pair on the boot section.

## NOTE

WDA sensors can be installed on the front of the elevator leg if side mounting is not possible. 4B recommends that all sensors be placed either on the side or on the front, but not in combinations.

### METAL ELEVATOR BUCKET SIDE MOUNTING DIAGRAMS -

#### NORMAL RUNNING

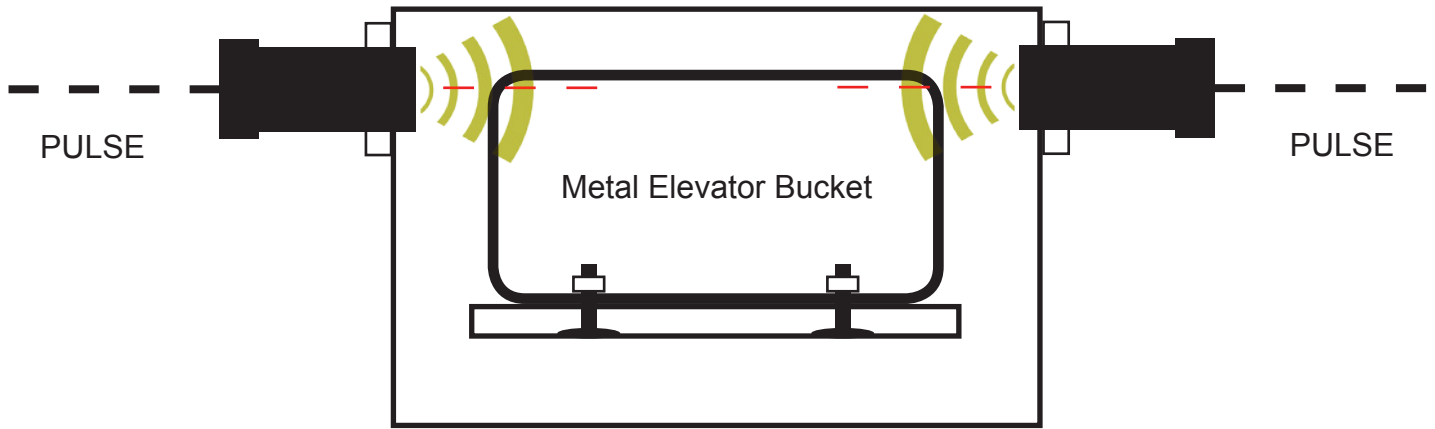

#### BELT MISALIGNMENT

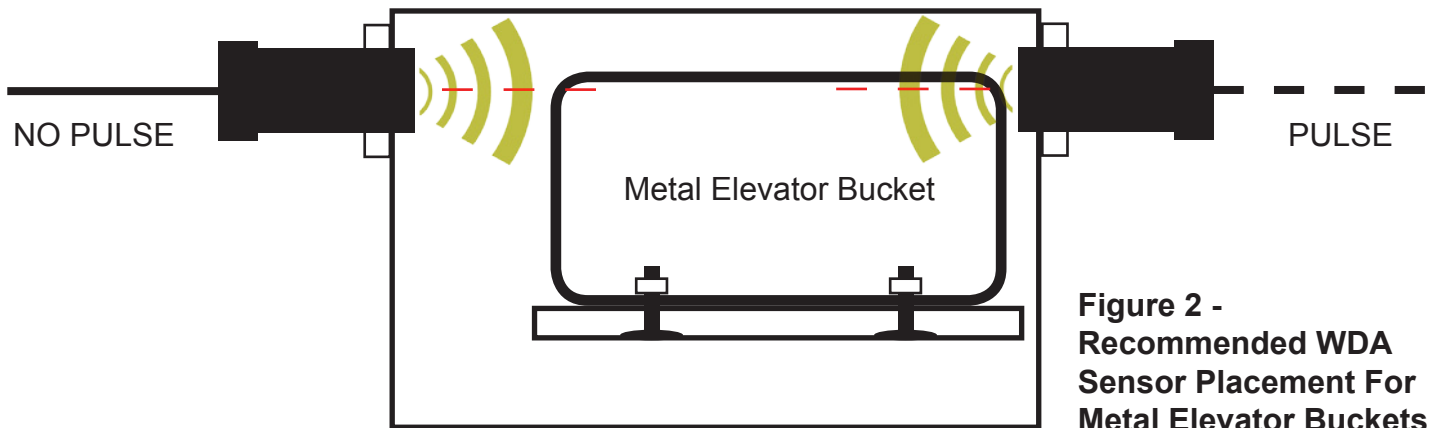

Figure 2 - Recommended WDA Sensor Placement For Metal Elevator Buckets

#### NOTE -

If using stainless steel elevator buckets and bolts (non-ferrous), use PTFE coated steel fender washers (ferrous) between the belt and bucket. Mount WDA sensor on the back side of the leg to target the ferrous bolts / washers.

Alternatively, 400 series stainless steel bolts (magnetic) can be use.

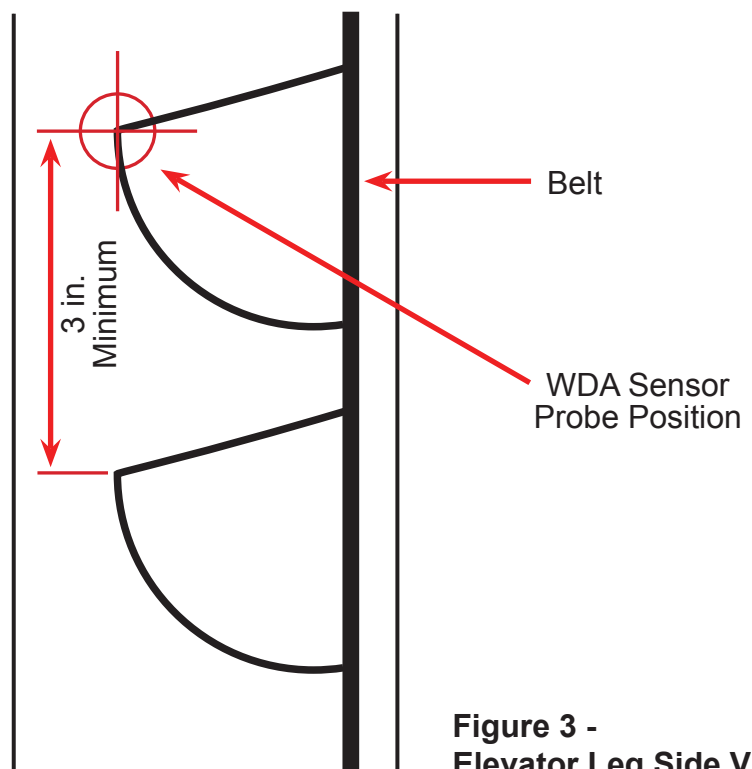
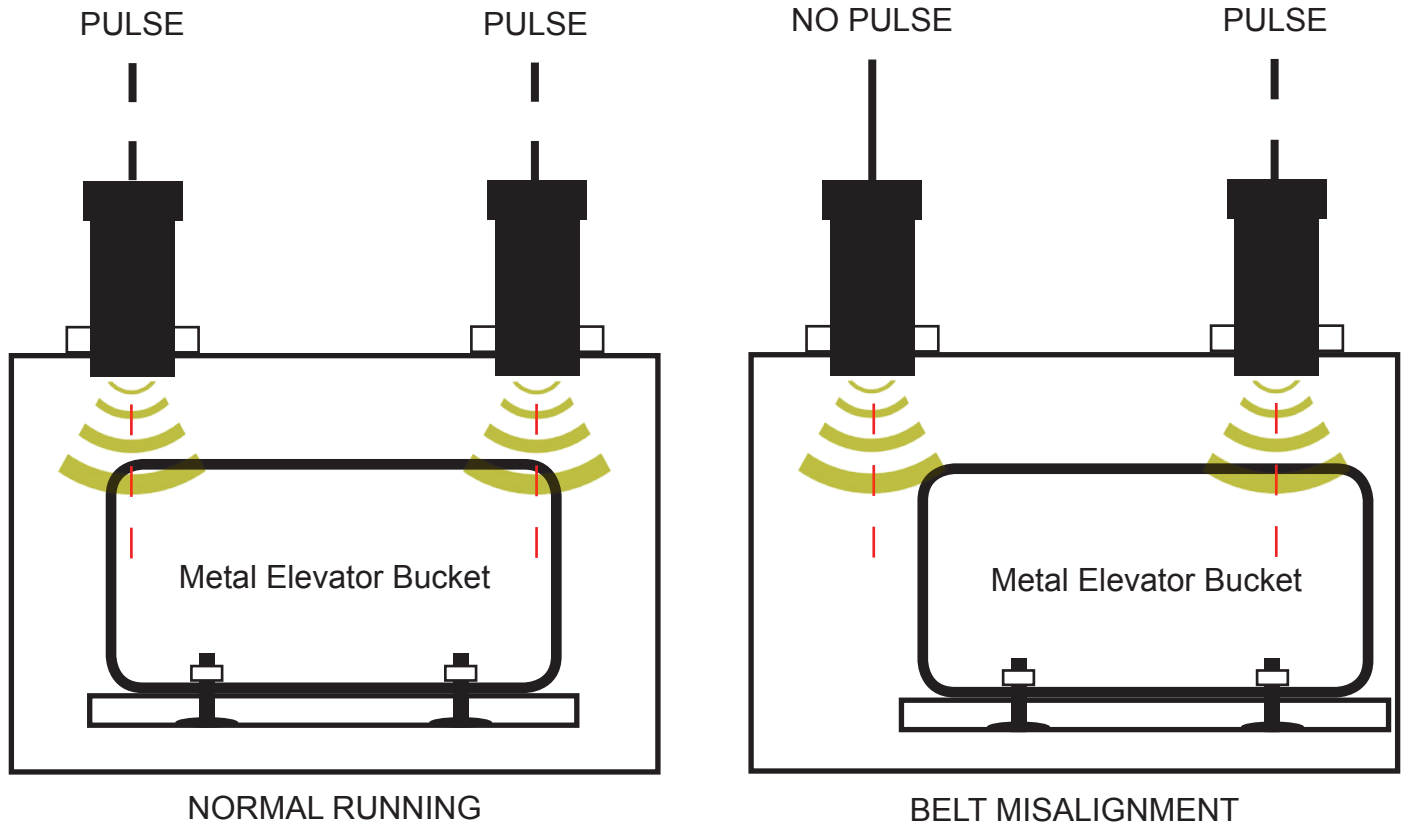

Figure 3 - Elevator Leg Side View

## METAL ELEVATOR BUCKET OPTIONAL FRONT MOUNTING DIAGRAMS -



**Figure 4 -  
Optional Front Mounting Of WDA  
Sensor For Metal Elevator Buckets**

## METAL ELEVATOR BUCKETS WITH CLOSE VERTICAL CENTERS -

Figure 5 illustrates the optimal WDA sensor placement for elevator buckets with close vertical spacing. This placement allows for the maximum differential between the buckets. GB Spidex™ and Starco™ low profile are two examples of these bucket types. For additional information, contact 4B.

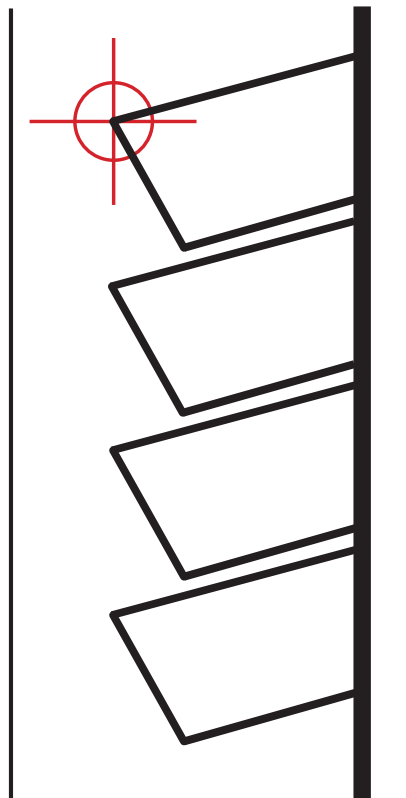

**Figure 5 -  
WDA Sensor Placement  
For Metal Buckets With  
Close Vertical Centers**

**PLASTIC ELEVATOR BUCKET MOUNTING DIAGRAMS -**

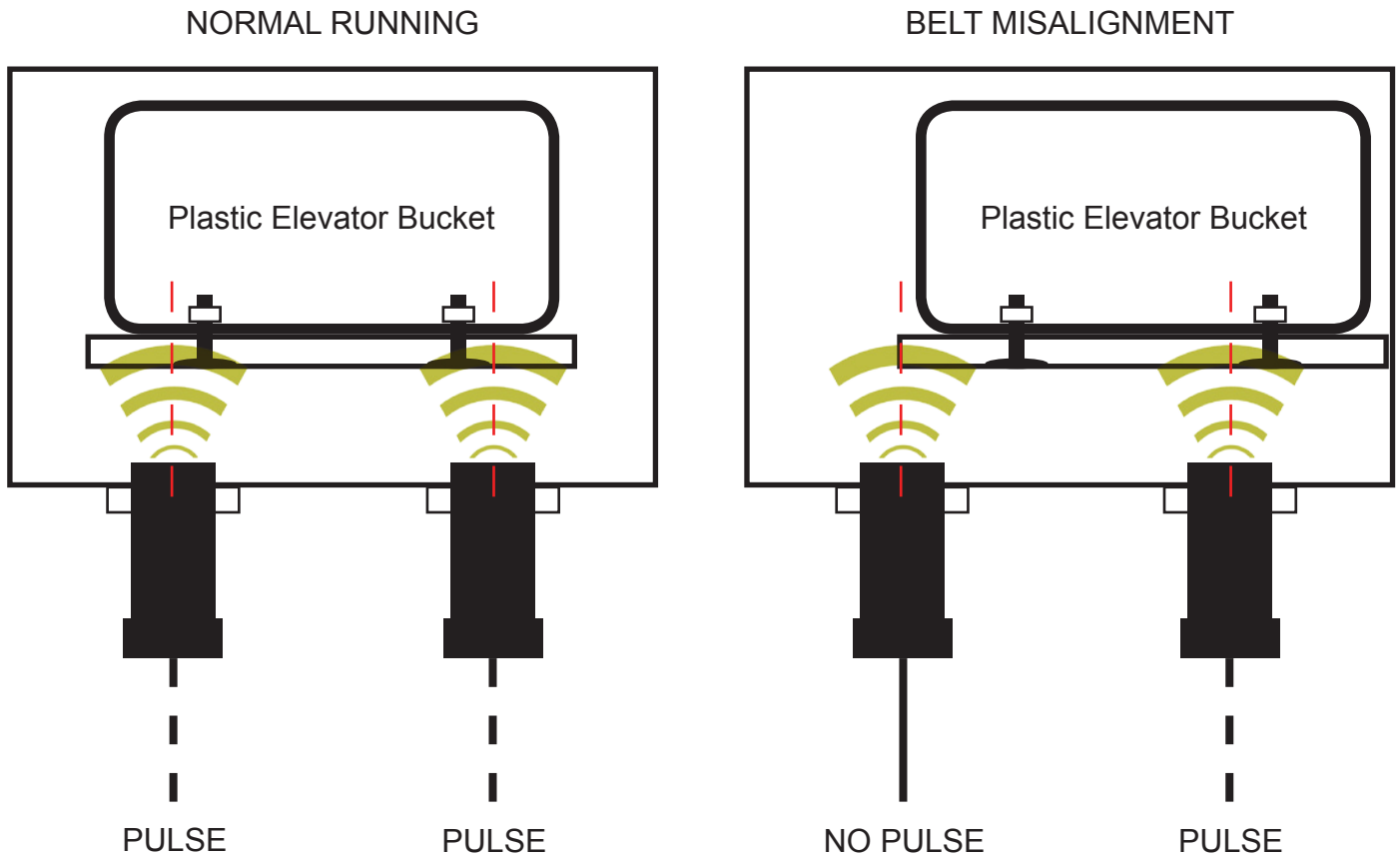

**Figure 6 -  
WDA Sensor Placement For Plastic Elevator Buckets (Detecting Bolts) On Up Side Of Leg**

If using stainless steel bolts (non-ferrous), use PTFE coated steel fender washers (ferrous) between the belt and bucket.

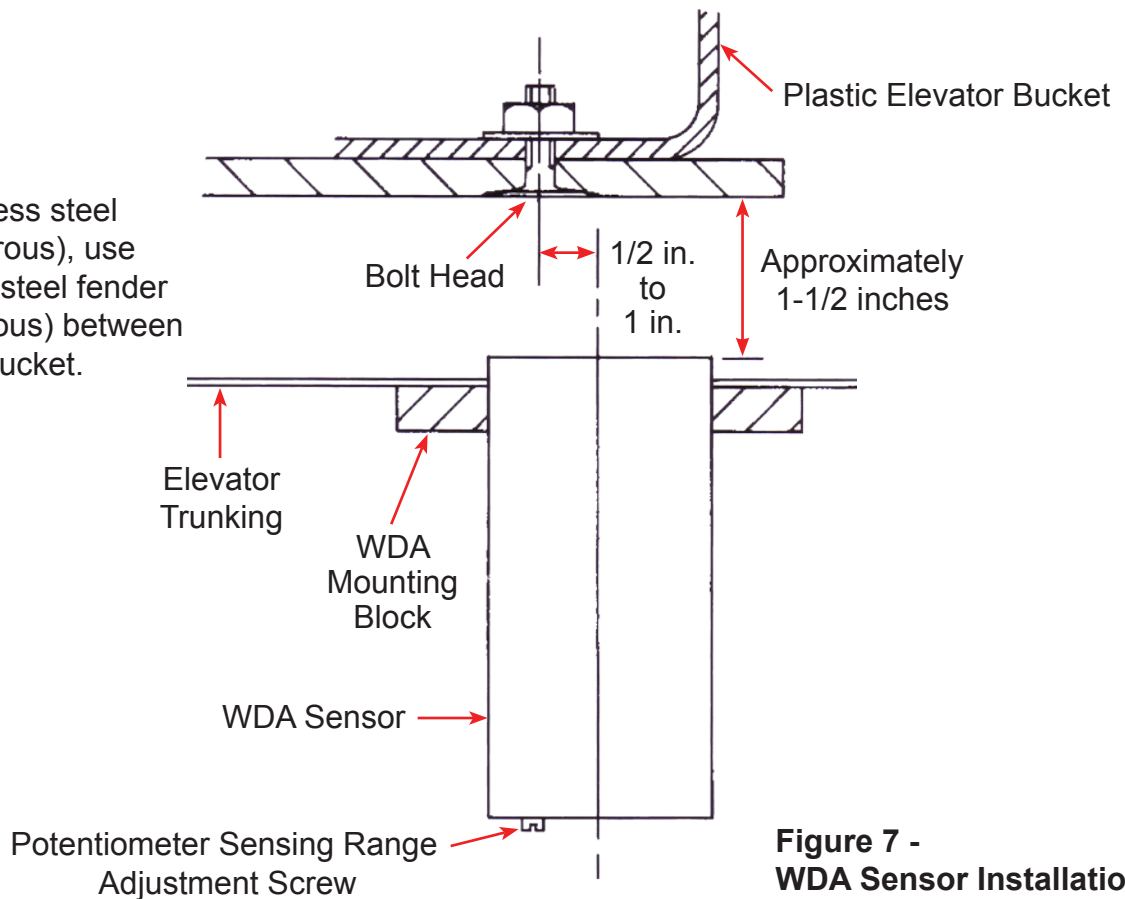

**Figure 7 -  
WDA Sensor Installation For Plastic Buckets**

# INSTALLATION - CONVEYORS

## SCREW CONVEYOR -

For speed monitoring on a screw conveyor, the sensor will need to detect a ferrous steel flight (target). If the housing is mild steel, cut a 4 inch or larger diameter hole in the housing and weld a 300 series stainless steel plate over the hole. Make sure that the plate is larger than the WDA's mounting bracket, and mount the WDA sensor to the stainless steel plate. The sensor should be mounted 1-3 inches away from the edge of the hole in the housing or it may detect the mild steel as a false target. Since 300 series stainless steel is non-ferrous, the sensor will not be affected as the sensing field can pass through the plate.

If the housing is 300 series stainless steel, no hole is required, mount the WDA3 sensor directly to the housing. The sensor should be mounted 1-3 inches away from the moving ferrous flight (target) but over 3 inches away from the rotating shaft. This installation is very similar to option 1 for drag conveyors.

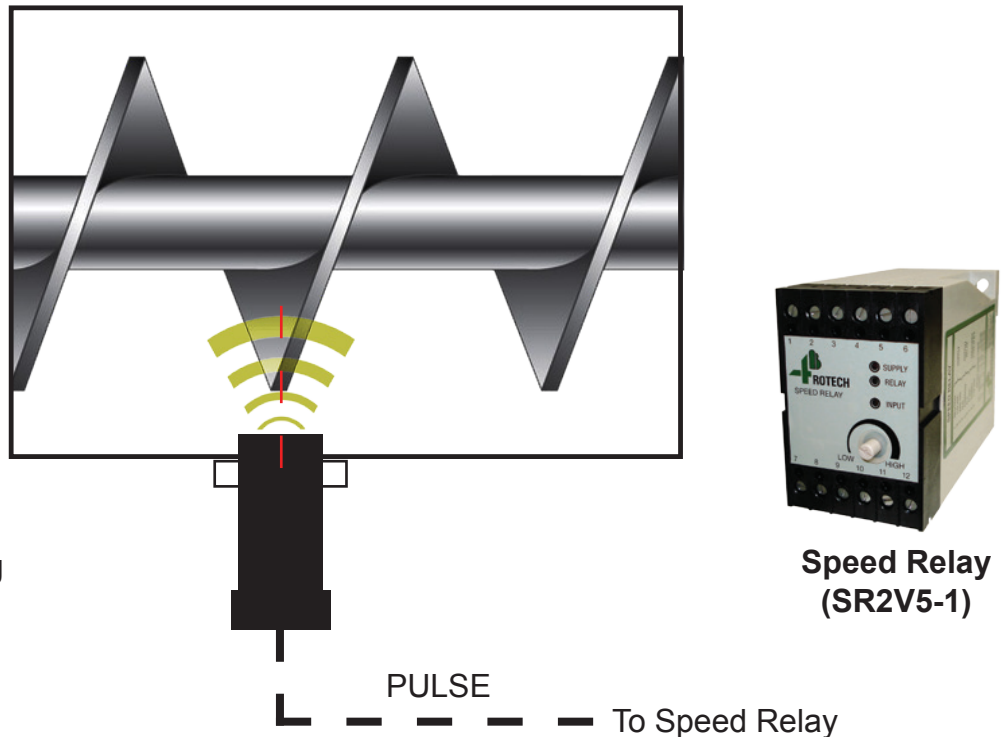

**Figure 8 -  
WDA Sensor Detecting  
Screw Flight (Pulse)**

**Speed Relay  
(SR2V5-1)**

## DRAG CONVEYOR -

For slack/broken chain detection on drag conveyors, the WDA sensor can be installed using one of three options (see below). Either a hole can be cut in the conveyor housing for the sensor, or the mount can be installed on a stainless steel plate welded directly to the conveyor housing over the hole. Since stainless steel is non-ferrous, the sensor will not be affected as the sensing field can pass through the plate.

Once the proper placement has been identified, cut a 2-1/4 inch (57 mm) diameter hole in the drag conveyor housing for each sensor. If using stainless steel plate, the hole diameter may need to be larger.

The WDA sensor can be mounted using one of the following three methods -

1. Drill and tap the machine casing for 5/16 inch threaded bolts. Make sure that the bolts used to secure the sensor mounting bracket are short enough that they do not interfere with the operation of the machine.
2. Use threaded rivet nuts for 5/16 inch threads. The length of the rivet nut will depend on the thickness of the machine's casing. Make sure that the bolts used to secure the sensor mounting bracket are short enough that they do not interfere with the operation of the machine.
3. CD weld 5/16 inch threaded welding studs to the machine casing.

To drill the four 5/16 inch bolt holes for the sensor mounting bracket, use the supplied paper template from the sensor manual or use the bracket itself, by centering on the existing 2-1/4 inch (57 mm) hole.

### OPTION 1: SENSOR DETECTING TARGET ON PADDLE -

Under normal running conditions, the target bolt passes through the sensor's field and a pulse is sent to the speed relay. If the chain becomes slack, the target bolt will drop below the field and the pulses will stop, causing the relay contact to change state.

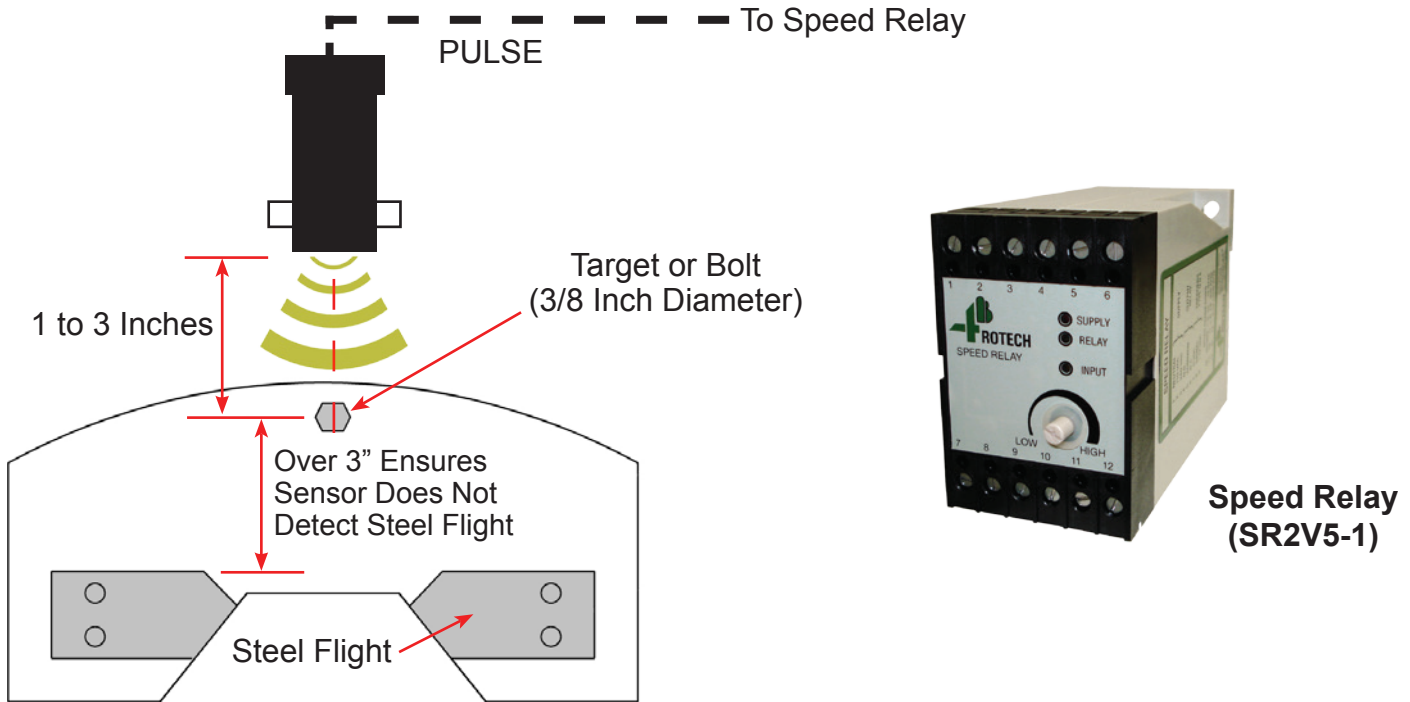

### OPTION 2: SENSOR DETECTING STEEL FLIGHT -

Under normal running conditions, the steel flight passes through the sensor's field and a pulse is sent to the speed relay. If the chain becomes slack, the steel flight will drop below the field and the pulses will stop, causing the relay contact to change state.

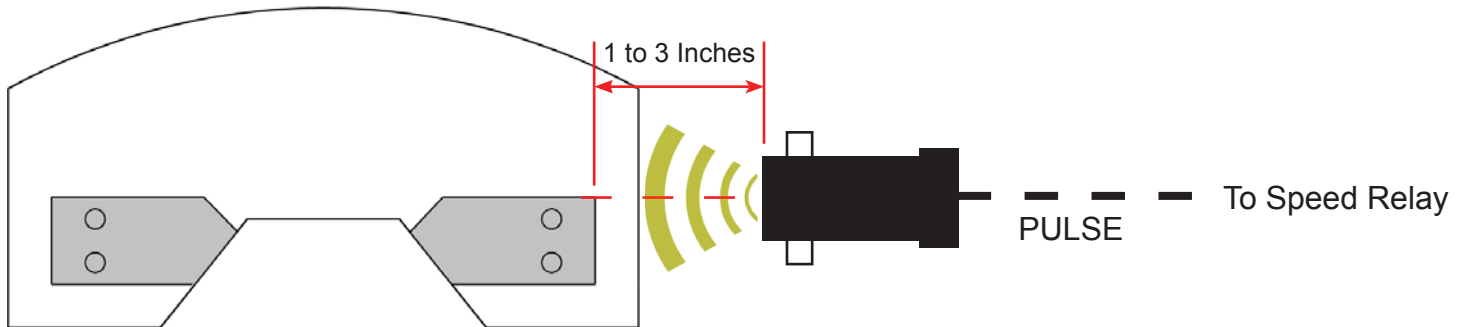

### OPTION 3: SENSOR WAITING TO DETECT STEEL FLIGHT -

Under normal running conditions, the steel flight is out of the sensor's field, so no pulses are sent to the speed relay. If the chain becomes slack, the steel flight comes into the sensor's field and a pulse is sent to the speed relay, causing it to change state.

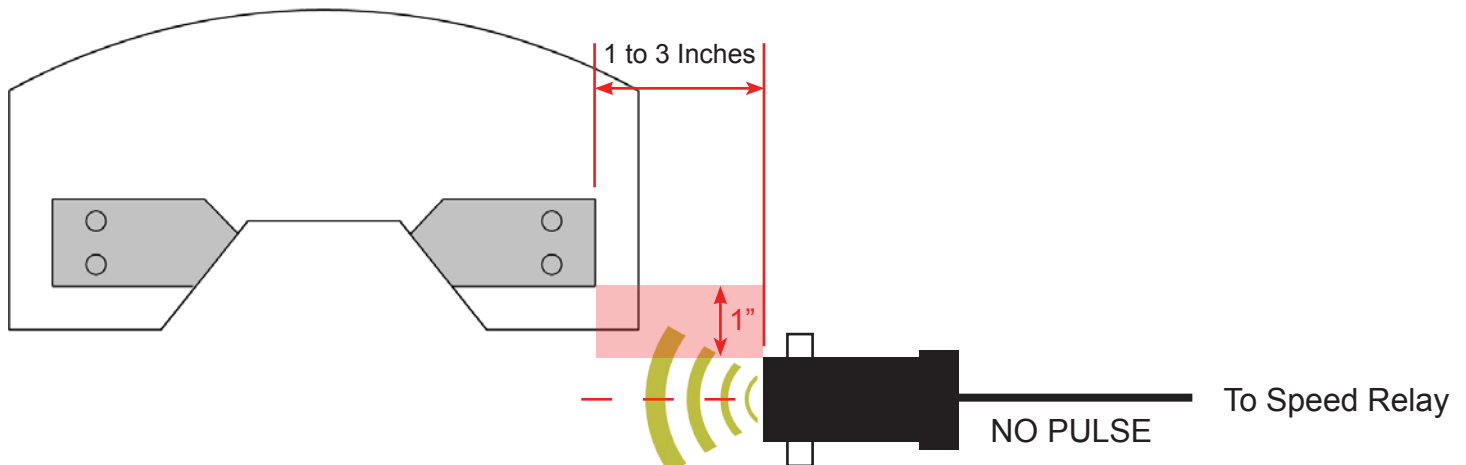

## NOTE

The sensor depth can be adjusted by loosening the adjustment bolt on the mounting bracket, sliding the sensor to the required depth and retightening the bolt. Final sensitivity adjustments should be made using the potentiometer sensing range adjustment screw.

## WARNING

Ensure that no ferrous steel, such as the machine's frame is within the target sensing field. This can interfere with the sensor detecting the intended target.

## STANDARD WIRING DIAGRAM

All wiring must be in accordance with local and national electrical codes and should be undertaken by an experienced and qualified electrician.

Always use dust/liquid tight flexible metal conduit with approved fittings to protect the sensor cables. Use rigid metal conduit to protect the cables from the sensors to the control unit. Conduit systems can channel water due to ingress and condensation directly to sensors and sensor connections which over time will adversely affect the performance of the system. As such, the installation of low point conduit drains is recommended for all sensors.

RED	+ Supply, 12 to 24 VDC $\pm$ 10%
BLACK	- Supply, 0 VDC
GREEN	Ground Connection
YELLOW / ORANGE	Control Signal 0 VDC to + VDC
BLUE	Pulsed Output. Normally Low, High When Detecting
WHITE	Continuous Output. Low when detecting, high when stopped for 2.5 seconds

To use the internal potentiometer within the WDA sensor, connect the YELLOW/ORANGE wire to the RED wire. Turn the sensing range adjustment screw clockwise to increase the sensing range.

## NOTE

If using the A400 Elite Trackswitch control unit, follow the wiring instructions for YELLOW/ORANGE wire as detailed in the A400 manual. Make sure to turn the sensing range adjustment screw on the WDA sensor fully counter-clockwise when using the A400.

If using the Watchdog™ Elite control unit, connect the YELLOW/ORANGE wire to the RED wire. Turn the sensing range adjustment screw clockwise to increase the sensing range.

### UPDATING FROM DISCONTINUED WDA1 MODEL -

If you are updating from the older and discontinued WDA1 (plastic body) to the current WDA sensor (stainless steel body), the wiring process is outline below:

WDA3	WDA1
RED	BROWN: +Supply VDC
BLACK	BLUE: - Supply VDC
GREEN	GREEN: Ground
YELLOW / ORANGE	----- Control
BLUE	BLACK: Pulsed Output
WHITE	----- Continuous Output

## SPEED RELAY WIRING DIAGRAM (SIMPLIFIED) -

The diagram below is a simplified wiring diagram for connecting the WDA sensor to a 4B Rotech Speed Relay (Model SR2V5-1). See speed relay and other applicable instructions for complete set-up and installation information.

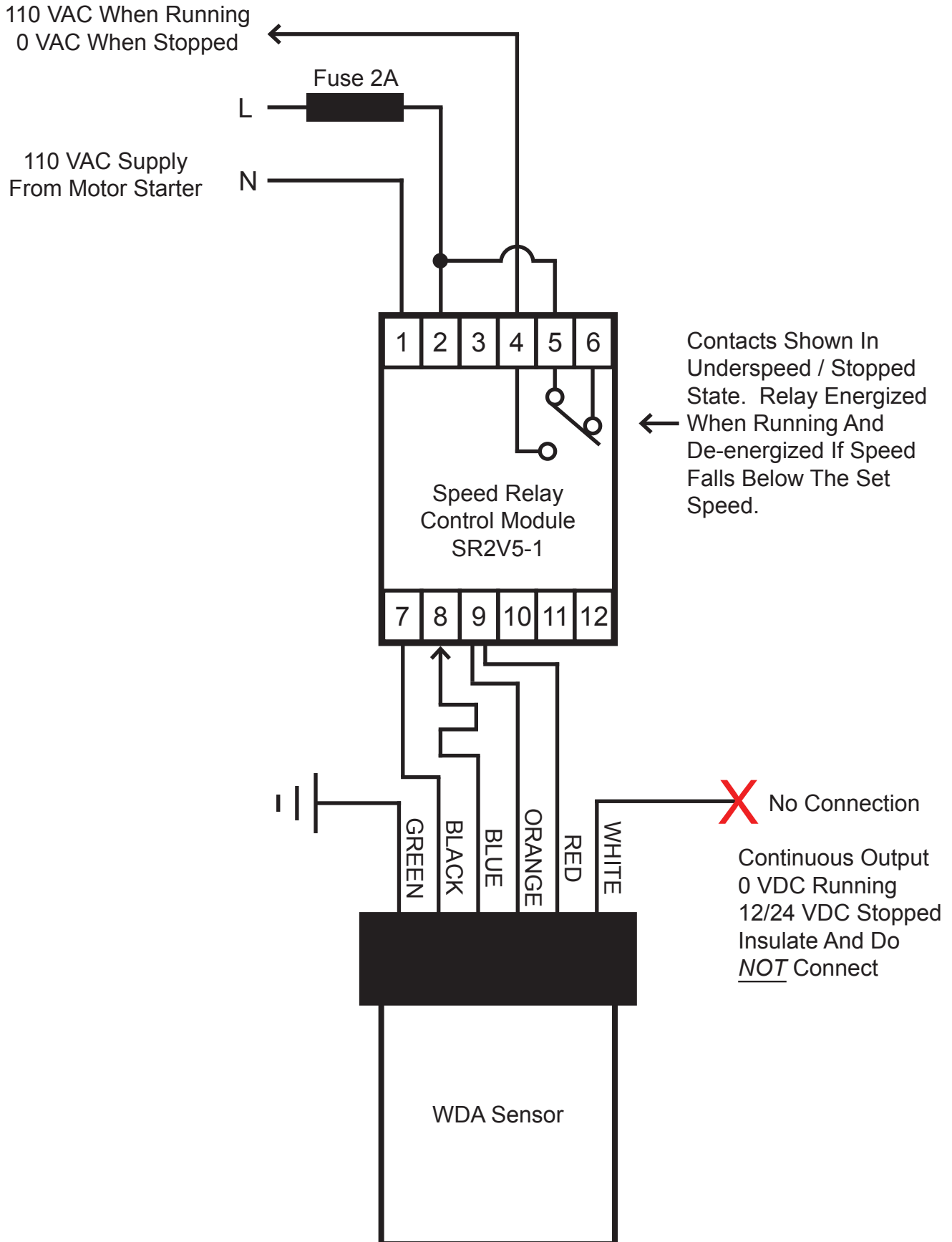



# SENSOR CALIBRATION

Turn the sensing range adjustment screw fully clockwise while machine is running, the green LED should flash consistently. Slowly turn the sensing range adjustment screw counter-clockwise until the flashing becomes irregular. Then turn it slowly clockwise until a regular flashing pattern appears, add an extra 1/8th turn clockwise for range compensation.

## TESTING AND COMMISSIONING

1. Check that the unit is correctly installed (see standard wiring diagram).
2. Check that the distance between the target and the sensing face of the WDA sensor is within the minimum distance specified.
3. Start up machine, the green LED shows the state of the pulsed output and flashes once for each target detected. The LED should be off when no target is detected, if not, reduce the sensitivity
4. If the sensor is not performing as expected, contact 4B.

### WARNING

If the system does not alarm as required, then remove the machine from service until the problem has been diagnosed and corrected.

## TROUBLESHOOTING GUIDE

FAULT	CAUSE	REMEDY
LED on alignment sensor does not flash	<ol style="list-style-type: none"> <li>1. Sensor too far away from target</li> <li>2. Sensor adjustment incorrect</li> <li>3. Faulty wire connection</li> <li>4. Object stuck to magnetic face of the sensor, causing interference</li> </ol>	<ol style="list-style-type: none"> <li>1. Move sensor closer to target</li> <li>2. Turn sensitivity control clockwise</li> <li>3. Check wiring</li> <li>4. Remove object</li> </ol>
LED on alignment sensor flashes excessively	<ol style="list-style-type: none"> <li>1. Sensor too close to target</li> <li>2. Sensor adjustment incorrect</li> <li>3. Interference in wiring</li> </ol>	<ol style="list-style-type: none"> <li>1. Move sensor away from target</li> <li>2. Turn sensitivity control counter clockwise</li> <li>3. Use shielded cable and rigid conduit</li> </ol>
Sensor will not calibrate	Wiring issue	<ol style="list-style-type: none"> <li>1. Make sure that the YELLOW/ ORANGE wire is connected to the RED wire</li> <li>2. Make sure that the YELLOW/ ORANGE wire is connected to the correct input on the controller</li> </ol>



## Watchdog™ Super Elite Hazard Monitoring Control System

The Watchdog Super Elite is a microprocessor controlled unit with combined belt speed, belt alignment, bearing temperature, pulley alignment and plugged condition monitoring for bucket elevators and conveyors. A 3.5" LCD screen displays the entire system status at a glance.

## A400 Elite Trackswitch Belt Alignment Monitor

The A400 Elite Trackswitch belt misalignment monitor uses 4B WDA magnetic proximity sensors to monitor the alignment of the belt in bucket elevators. Each control unit incorporates two independent monitoring circuits for early detection of belt misalignment on one or two bucket elevators.



## WDA High Temperature Sensor (HTAS1V34)

Non-contacting extended range magnetic proximity sensor, not affected by dust or material build up, used to detect moving ferrous material up to 3 inches away from the sensor. Designed for temperatures ranging from 302° F (continuous) to 356° F (maximum).



## Speed Relay (SR2V5-1)

DIN rail mounted speed relay with a user adjustable underspeed relay contact output that can sound an alarm or shutdown machinery when the shaft speed falls below the preset level.

## WDA Sensor Mount (WDAMB)

Plastic mount for the WDA sensor (included with sensor).

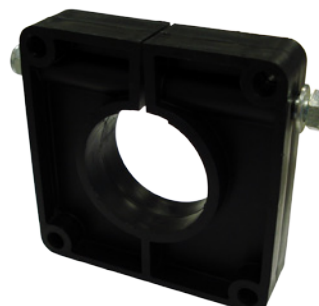

# PRODUCT WARRANTY

## 1. EXCLUSIVE WRITTEN LIMITED WARRANTY

ALL PRODUCTS SOLD ARE WARRANTED BY THE COMPANY 4B COMPONENTS LIMITED AND 4B BRAIME COMPONENTS LIMITED HEREIN AFTER REFERRED TO AS 4B TO THE ORIGINAL PURCHASER AGAINST DEFECTS IN WORKMANSHIP OR MATERIALS UNDER NORMAL USE FOR ONE (1) YEAR AFTER DATE OF PURCHASE FROM 4B. ANY PRODUCT DETERMINED BY 4B AT ITS SOLE DISCRETION TO BE DEFECTIVE IN MATERIAL OR WORKMANSHIP AND RETURNED TO A 4B BRANCH OR AUTHORIZED SERVICE LOCATION, AS 4B DESIGNATES, SHIPPING COSTS PREPAID, WILL BE, AS THE EXCLUSIVE REMEDY, REPAIRED OR REPLACED AT 4B'S OPTION.

## 2. DISCLAIMER OF IMPLIED WARRANTY

NO WARRANTY OR AFFIRMATION OF FACT, EXPRESSED OR IMPLIED, OTHER THAN AS SET FORTH IN THE EXCLUSIVE WRITTEN LIMITED WARRANTY STATEMENT ABOVE IS MADE OR AUTHORIZED BY 4B. 4B SPECIFICALLY DISCLAIMS ANY LIABILITY FOR PRODUCT DEFECT CLAIMS THAT ARE DUE TO PRODUCT MISUSE, ABUSE OR MISAPPLICATIONS, AS AUTHORIZED BY LAW, 4B SPECIFICALLY DISCLAIMS ALL WARRANTIES THAT THE PRODUCT IS FIT OR MERCHANTABLE FOR A PARTICULAR PURPOSE.

## 3. NO WARRANTY "BY SAMPLE OR EXAMPLE"

ALTHOUGH 4B HAS USED REASONABLE EFFORTS TO ACCURATELY ILLUSTRATE AND DESCRIBE THE PRODUCTS IN ITS CATALOGS, LITERATURE, AND WEBSITES, SUCH ILLUSTRATIONS AND DESCRIPTIONS ARE FOR THE SOLE PURPOSE OF PRODUCT IDENTIFICATION AND DO NOT EXPRESS OR IMPLY A WARRANTY AFFIRMATION OF FACT, OF ANY KIND OR A WARRANTY OR AFFIRMATION OF FACT THAT THE PRODUCTS WILL CONFORM TO THEIR RESPECTIVE ILLUSTRATIONS OR DESCRIPTIONS. 4B EXPRESSLY DISCLAIMS ANY WARRANTY OR AFFIRMATION OF FACT, EXPRESSED OR IMPLIED, OTHER THAN AS SET FORTH IN THE EXCLUSIVE WRITTEN LIMITED WARRANTY STATEMENT ABOVE, INCLUDING, WITHOUT LIMITATION, THE IMPLIED WARRANTIES OF MERCHANTABILITY AND FITNESS FOR A PARTICULAR PURPOSE.

## 4. LIMITATION OF DAMAGES

ANY LIABILITY FOR CONSEQUENTIAL, INCIDENTAL, SPECIAL, EXEMPLARY, OR PUNITIVE DAMAGES, OR FOR LOSS OF PROFIT WHETHER DIRECT OR INDIRECT, IS EXPRESSLY DISCLAIMED.

With subsidiaries in North America, Europe, Asia, Africa and Australia along with a worldwide network of distributors, 4B can provide practical solutions for all your applications no matter the location.



**4B BRAIME COMPONENTS**

Hunslet Road  
Leeds  
LS10 1JZ  
United Kingdom  
Tel: +44 (0) 113 246 1800  
Fax: +44 (0) 113 243 5021

**4B DEUTSCHLAND**

9 Route de Corbie  
Lamotte Warfusée  
F-80800  
France  
Tel: +49 (0) 700 2242 4091  
Fax: +49 (0) 700 2242 3733

**4B ASIA PACIFIC**

Build No. 899/1 Moo 20  
Soi Chongsiri, Bangplee-Tam Ru Road,  
Tanbon Bangpleeyai, Amphur Bangplee,  
Samutprakarn 10540  
Thailand  
Tel: +66 (0) 2 173-4339  
Fax: +66 (0) 2 173-4338

**4B COMPONENTS LTD.**

625 Erie Avenue  
Morton, IL 61550  
USA  
Tel: 309-698-5611  
Fax: 309-698-5615

**4B FRANCE**

9 Route de Corbie  
80800 Lamotte Warfusée  
France  
Tel: +33 (0) 3 22 42 32 26  
Fax: +33 (0) 3 22 42 37 33

**4B AFRICA**

14 Newport Business Park  
Mica Drive, Kya Sand  
2163 Johannesburg  
South Africa  
Tel: +27 (0) 11 708 6114  
Fax: +27 (0) 11 708 1654

**4B AUSTRALIA**

Unit 1/18 Overlord Place  
Acacia Ridge  
Queensland 4110  
Australia  
Tel: +61 (0) 7 3711 2565  
Fax: +61 (0) 7 3711 2574

[www.go4b.com](http://www.go4b.com)