

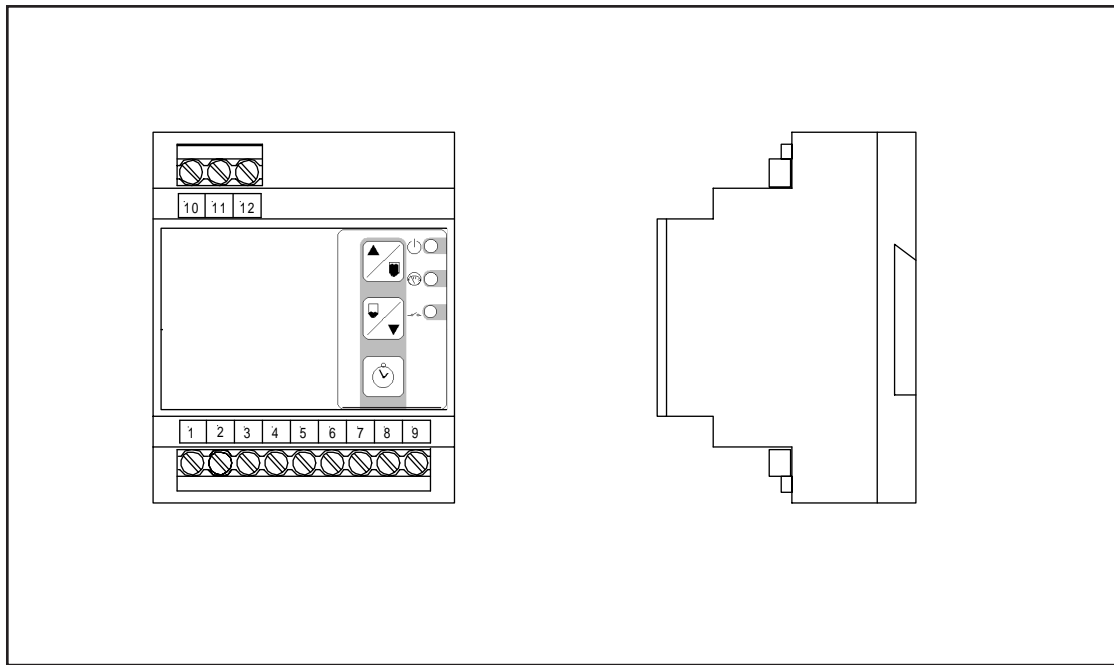

AUTOSET REMOTE

Remote Mounting, Auto Calibrating Level Control
with full manual override



**DIGITALLY CALIBRATED, REMOTE
LEVEL CONTROL SYSTEM**
(incorporating ATSREM1V0 Controller & ATSTRAN1 Insert)

INSTALLATION INSTRUCTIONS

TECHNICAL INFORMATION

Introduction

The Autoset remote is a fixed point level measuring system comprising a remotely mounted probe and separate control unit. The control unit, which may be mounted up to 200 metres from the probe, incorporates all adjustment and calibration facilities.

The remotely mounted probe normally contains an encapsulated electronic insert. If necessary, the insert can be external to the probe and connected via a short length of screened cable.

The Autoset remote is ideal for installations where accessibility, vibration, space restriction or temperature prevent the use of a self contained version. Most Autoset features are retained, including full auto/manual calibration and, with most probe assemblies, the 'Power Shield' which minimises the effect of residual material sticking to the probe.

Connections

Autoset remote will operate on 24Vdc, or 110V/230V ac 50/60Hz supplies. Power connections to the unit may be wired in ordinary un-screened cable of any length and need not be separated from other cables. Connections between control unit and insert must be made in 2 core screened cable (200 metres max.). Where the electronic insert is mounted separately from the probe, connections between them should be made in single core screened cable. The length should be as short as possible and must not exceed 500mm.

Connect in accordance with fig 1 (probe with integral insert) or fig 2 (probe with external insert), and set fail safe switch to required position (see fig 4), ensure that all cable glands and covers are fully tightened when finished. The unit should be wired and grounded in accordance with appropriate Electrical Regulations.

On metal containers, the probe earth (where fitted) MUST be bonded to the container. If the container is non-metallic, metal flanges or couplings used to mount probe should be bonded to earth. This also applies to probes mounted in wooden or plastic tops of metal bins.

Installation

On probe assemblies with separate rods/wire ropes, a thread locking compound is normally pre-applied. The probe rod should be fitted to the probe assembly and hand tightened. The assembly will lock within 20 minutes and harden over 24 hours.

(fig 1)

Typical Connections - Probe with integral insert

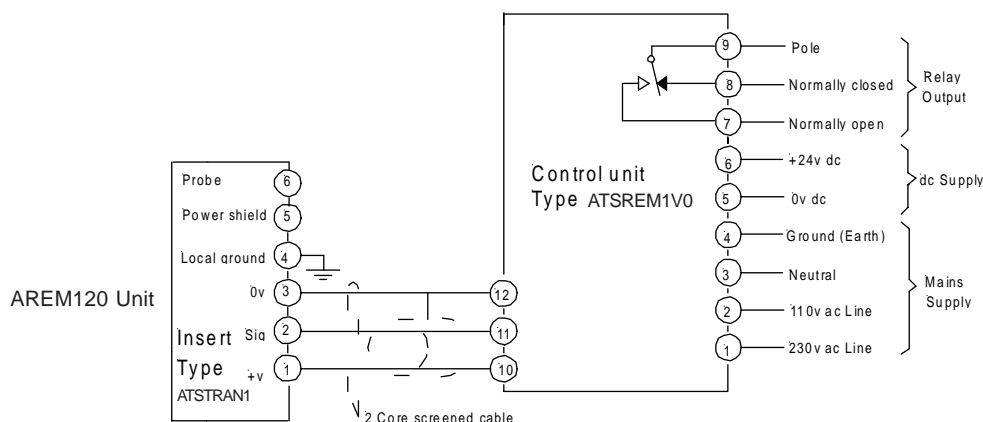

(fig 2)

Typical Connections - Probe with external insert

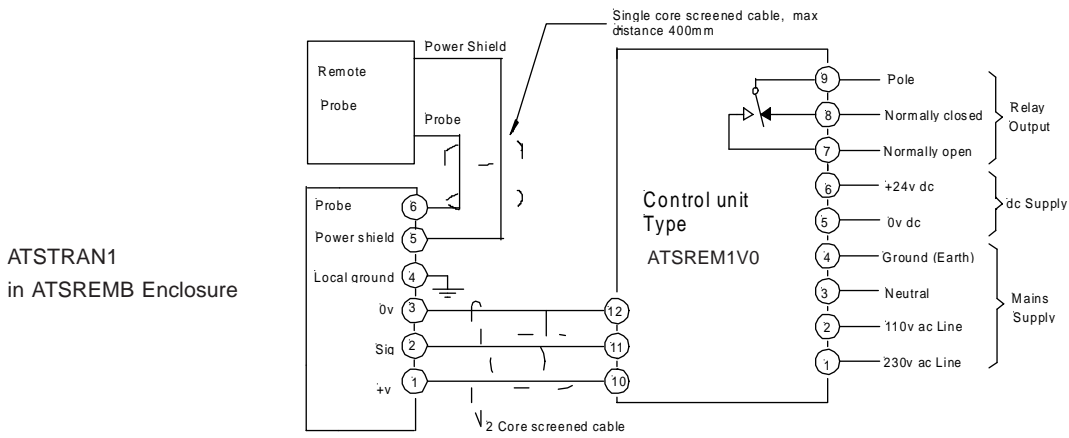

When mounting probes with Power Shields, care must be taken to ensure that the exposed end of the power shield protrudes into the container. See fig 3 Mount unit securely to minimise vibration.

(fig 3)

Typical Probe Head Arrangement - showing power shield mounting.

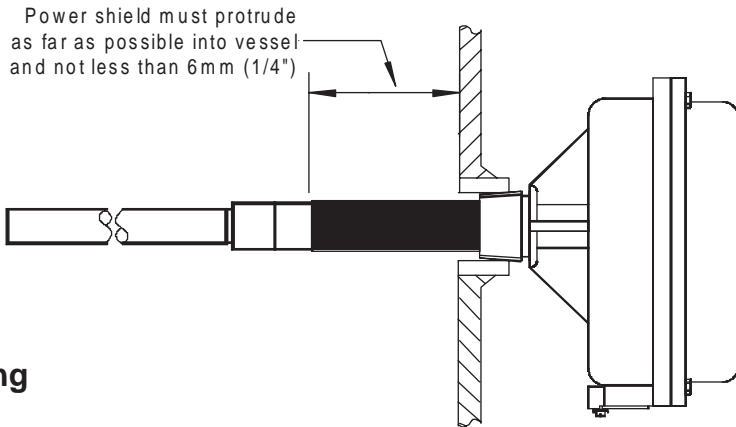

Fail Safe Setting

The 'High/Low' switch (fig 4), sets the fail safe mode. In the 'High' position, the relay is de-energised with material present. In the 'Low' position, the relay is energised with material present. Normally, the 'High' position is used for high level probes and the 'Low' for low level probes. Intermediate probe settings depend upon individual requirements.

(fig 4)

Switch Settings

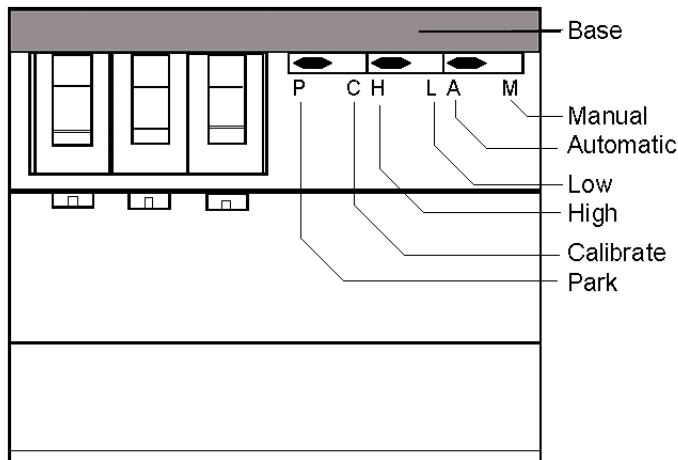

Commissioning

The Autoset remote can be calibrated automatically, manually or by a combination of both methods. After initial calibration, the unit can be re-calibrated by any of the methods detailed, as and when required.

IMPORTANT - The 'CAL/PARK' switch must be set to the 'CAL' position when calibrating the unit otherwise, all push buttons are disabled.

Automatic calibration is generally the best method if material is available. If the unit is to be manually calibrated, it should be calibrated automatically or semi automatically first, and then modified afterwards.

Automatic Calibration - Material Available

- 1) Set the 'CAL/PARK' switch to the 'CAL' position and set the auto/manual switch to the 'A' position (fig 4).
- 2) With the probe uncovered, press and release the 'uncovered' button. The CAL LED will flash slowly for about 2 seconds and then rapidly for about 8 seconds. 'Uncovered' calibration is now complete.
- 3) Fill the container to cover the probe to the required trip level with vertical probes, and completely cover the probe for horizontally mounted ones.
- 4) Press the calibrate 'covered' button. The LED will flash for about 2 seconds.
- 5) Calibration is now complete. Set any time delay required and then set the 'CAL/PARK' switch to the 'PARK' position. The CAL light will now illuminate when the probe is covered.

Semi Automatic Calibration - Material Not Available Method 1

Note: Read these instructions carefully before calibrating. This method uses a 'time out' feature and calibration will be incorrect if the time out occurs before completion.

- 6) Proceed as per step 1 above.
- 7) Press and release the uncovered button. The CAL LED will flash slowly for about 2 seconds, and will then flash rapidly for about 8 seconds.
- 8) Whilst the CAL LED is flashing at high speed, press the uncovered button up to 99 times to set the desired calibration. The time out feature is reset back to 8 seconds each time the button is pressed. Typical settings are given in the chart below.
- 9) 8 seconds after the last press, the unit will time out and then the calibrate LED will flash for the number of presses entered to confirm the setting.
- 10) See step 5.

Semi Automatic Calibration - Material Not Available Method 2

- 11) Return the unit to Factory Setting by following 'Automatic Calibration - Material Available', but carry out the complete procedure without covering the probe. The unit will recognise that covered and uncovered settings are the same and will return to factory defaults. This setting will be too sensitive for most applications.

- 12) Set the auto/manual switch to 'M'.
- 13) Press the covered button to reduce sensitivity (raise switching point) and the uncovered button to increase sensitivity (lower switching point). Each short button press equals one step. Alternatively, the button may be held down and each LED flash then equals one step. Typical settings are given below. Insert these values by operating the covered button. This will raise the switch point by the required amount.
- 14) See step 5. Unit can be left in manual mode or returned to auto mode for auto calibration when material is available.

Material	No. of Presses
Light. (grass, grain etc.)	5
Medium. (flour, oil etc.)	10
Heavy. (sand, aggregates etc.)	15

Typical values to add during manual setting process.

Timer

To set the timer, 'CAL/PARK' switch must be in 'CAL' position. Press timer button for the time period required. CAL LED flashes indicate the time in seconds being set.

To cancel timer, press button for less than 1 second.

Return to PARK mode - See step 5.

Notes:-

- a) The units sensitivity is proportional to the surface area of the probe. The standard 100mm x 20mm diameter probe is ideal for the majority of materials and should be treated as the minimum if possible.

If the probe length needs to be reduced, the surface area should be maintained. This can be achieved by increasing the diameter, or by fitting a metal tube over the probe. In certain high density materials it may be possible to reduce the length without compensation.

Autoset Remote Overall Specification

ATSREM1V0 Control Unit

Protection:	IP44.
Enclosure:	Moulded.
Mounting:	Din Rail.
Voltage:	24V dc, 110V/230V ac 50/60 Hz (+7½% -15%).
Rating:	2.5VA.
Operating Temperature:	-10 to + 45 C.
Output:	S.P.C.O. contacts rated at 2.5A 240V non-inductive.
Time Delay:	0 - 129 second variable. Set via push button. Delay applies when material arrives and leaves the probe.

Max.distance between control unit and probe assembly:

200 Metres in 2 core screened cable.

Probe Assembly Type (Typical) (Contact sales dept. for detailed specification).

Protection:	IP65.
Material:	Modified Polyamide 66 and stainless.
Earth Bonding:	Earth stud located on exterior of main case. This stud must be connected to earth, bonded to container or metalwork or container and, if used, connected to exterior of armour cabling.
Probe Length:	100mm, 1 metre, 2 metre or 10 metre wire rope.
Probe Electronic Insert Type:	DCT1.
Max. distance between remote insert and probe head:	500mm in single core screened cable.

ATSREM1V0 Dimensions

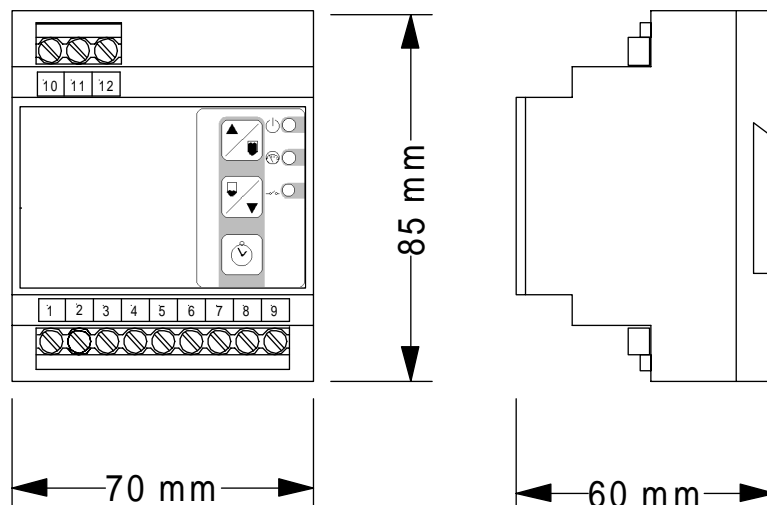

Conditional Limited Warranty

4B Elevator Components Ltd (4B) will pay the purchase price or repair and replace any non-conforming goods or parts, provided the purchase returns the product within one year from the date of purchase, and upon 4B's inspection, and sole discretion, 4B determines the defect or non-conforming part was caused by faulty material or workmanship. This warranty is void if the product has been repaired or serviced by anyone unauthorised by 4B, and/or if the product was not installed as required by the installation instructions which accompany the product at the time of its sale. No other warranty, however expressed or implied, is extended to any other party, and there are no other warranties, or guaranties which extend beyond this Conditional Limited Warranty. Replacement or repayment of the purchase price is the exclusive remedy of this Conditional Limited Warranty.

CERTIFICATE OF CONFORMITY

The equipment covered by these instructions have been manufactured and tested in accordance with our quality assurance procedures and conforms fully with our published specifications.

HEALTH AND SAFETY

Provided that the equipment covered by these instructions are installed and operated as directed, it presents no hazard and conforms fully to health and safety regulations.



THIS PRODUCT CONFORMS TO THE REQUIREMENTS FOR CE MARKING

When this product is incorporated into other machinery or apparatus, that apparatus must not then be put into service (in the E.C) until it has been declared in conformity with the appropriate E.C Directive/s.



**BRAIME ELEVATOR
COMPONENTS LTD.**

Hunslet Rd. Leeds LS10 1JZ
England. Tel. 0113 246 1800
Fax. 0113 243 5021



**4B ELEVATOR
COMPONENTS LTD.**

729 Sabrina Drive.
East Peoria. IL 61611 US
Tele. 309 698 5611
Fax. 309 698 5615



**SERVICE TECNICO-
COMMERCIAL FRANCE**

Bat. Anne de Bretagne-
1 bis. rue Julien Videment-
44200 NANTES, FRANCE.
Tel.. 03 22. 42. 32. 26
Fax 03 40.20.44.71