



# T400N Elite - Hotswitch

## BEARING TEMPERATURE MONITOR



### INSTALLATION INSTRUCTIONS

# OPERATION MANUAL

Part No. T4004NV46C / T4004NV4C

[www.go4b.com/usa](http://www.go4b.com/usa)



# TABLE OF CONTENTS

CUSTOMER SAFETY RESPONSIBILITIES	Page 4 - 5
PRODUCT OVERVIEW	Page 6
SPECIFICATIONS	Page 6
OPERATION -	Page 7
• Zoning	Page 7
• User Display	Page 7
• Alarm Relay & Alarm Conditions	Page 7
• Temperature Alarm Settings	Page 8
• Unused Sensor Inputs	Page 8
• Stop Conditions	Page 8
• Mute Button Operation	Page 8
• Test Button Operation	Page 10
• RS485 Data Monitoring	Page 10
ELECTRICAL CONNECTION -	Page 10
• Fuse Ratings	Page 10
ELECTRICAL DRAWINGS	Page 12 - 13
RS485 PROTOCOL -	Page 14
• Communication Specifications	Page 14
• Sending a Packet to T400N	Page 14
• Master Receive Packet	Page 14
• Decoding a Received Packet	Page 15
INSTALLATION INSTRUCTIONS	Page 16
TROUBLESHOOTING GUIDE	Page 17
NOTES	Page 18
PRODUCT WARRANTY	Page 19

Dear 4B Customer:

Congratulations on your purchase. 4B appreciates your business and is pleased you have chosen our products to meet your needs.

Please read in its entirety and understand the literature accompanying the product before you place the product into service. Please read the safety precautions carefully before operating the product. With each product you purchase from 4B, there are some basic but important safety considerations you must follow to be sure your purchase is permitted to perform its design function and operate properly and safely, giving you many years of reliable service. Please read and understand the Customer Safety Responsibilities listed below. Failure to follow this safety directive and the Operation Manuals and other material furnished or referenced, may result in serious injury or death.

### ***SAFETY NOTICE TO OUR CUSTOMERS***

- A. In order to maximize efficiency and safety, selecting the right equipment for each operation is vital. The proper installation of the equipment, and regular maintenance and inspection is equally important in continuing the proper operation and safety of the product. The proper installation and maintenance of all our products is the responsibility of the user unless you have asked 4B to perform these tasks.
- B. All installation and wiring must be in accordance with Local and National Electrical Codes and other standards applicable to your industry. (Please see the article “Hazard Monitoring Equipment Selection, Installation and Maintenance” at [www.go4b.com](http://www.go4b.com).) The installation of the wiring should be undertaken by an experienced and qualified professional electrician. Failure to correctly wire any product and/or machinery can result in the product or machine failing to operate as intended, and can defeat its design function.
- C. Periodic inspection by a qualified person will help assure your 4B product is performing properly. 4B recommends a documented inspection at least annually and more frequently under high use conditions.
- D. Please see the last page of this manual for all warranty information regarding this product.

### ***CUSTOMER SAFETY RESPONSIBILITIES***

#### **1. READ ALL LITERATURE PROVIDED WITH YOUR PRODUCT**

Please read all user, instruction and safety manuals to ensure that you understand your product operation and are able to safely and effectively use this product.

#### **2. YOU BEST UNDERSTAND YOUR NEEDS**

Every customer and operation is unique, and only you best know the specific needs and capabilities of your operation. Please call the 24-hour hotline at 309-698-5611 for assistance with any questions about the performance of products purchased from 4B. 4B is happy to discuss product performance with you at any time.

### **3. SELECT A QUALIFIED AND COMPETENT INSTALLER**

Correct installation of the product is important for safety and performance. If you have not asked 4B to perform the installation of the unit on your behalf, it is critical for the safety of your operation and those who may perform work on your operation that you select a qualified and competent electrical installer to undertake the installation. The product must be installed properly to perform its designed functions. The installer should be qualified, trained, and competent to perform the installation in accordance with Local and National Electrical Codes, all relevant OSHA Regulations, as well as any of your own standards and preventive maintenance requirements, and other product installation information supplied with the product. You should be prepared to provide the installer with all necessary installation information to assist in the installation.

### **4. ESTABLISH AND FOLLOW A REGULAR MAINTENANCE AND INSPECTION SCHEDULE FOR YOUR 4B PRODUCTS**

You should develop a proper maintenance and inspection program to confirm that your system is in good working order at all times. You will be in the best position to determine the appropriate frequency for inspection. Many different factors known to the user will assist you in deciding the frequency of inspection. These factors may include but are not limited to weather conditions; construction work at the facility; hours of operation; animal or insect infestation; and the real-world experience of knowing how your employees perform their jobs. The personnel or person you select to install, operate, maintain, inspect or perform any work whatsoever, should be trained and qualified to perform these important functions. Complete and accurate records of the maintenance and inspection process should be created and retained by you at all times.

### **5. RETAIN AND REFER TO THE OPERATION MANUAL FOR 4B'S SUGGESTED MAINTENANCE AND INSPECTION RECOMMENDATIONS**

As all operations are different, please understand that your specific operation may require additional adjustments in the maintenance and inspection process essential to permit the monitoring device to perform its intended function. Retain the Operation Manual and other important maintenance and service documents provided by 4B and have them readily available for people servicing your 4B equipment. Should you have any questions, please call the free 24-hour hotline number (309-698-5611).

### **6. SERVICE REQUEST**

If you have questions or comments about the operation of your unit or require the unit to be serviced please contact the 4B location who supplied the product or send your request via fax (309-698-5615) or call us via our 24-hour hotline number in the USA (309-698-5611). Please have available product part numbers, serial numbers, and approximate date of installation. In order to assist you, after the product has been placed into service, complete the online product registration section which is accessed via our website [www.go4b.com/usa](http://www.go4b.com/usa).

## WARNING

- Rotating machinery can cause serious injury or death
- Always lockout and tagout the machine prior to installation

## PRODUCT OVERVIEW

The T400N ELITE is a standalone monitoring and shutdown controller. The T400N operates by reading up to 8 NTC temperature sensors and comparing their temperature to a pre-set limit. If that limit is exceeded the unit will activate an alarm, followed by operating a stop relay after a specified delay. The unit is fitted with a MUTE and TEST button. An RS485 connection is provided to allow the remote collection and monitoring of each sensor input.

## SPECIFICATIONS

Input Supply Voltage	120 to 240 VAC or 24 VDC (T4004NV46C) 24 VDC (T4004NV4C)
Alarm Relay Contacts	Zone 1 - 1 Pole Normally Open - 8 A @ 250 VAC Zone 2 - 1 Pole Normally Open - 8 A @ 250 VAC
Stop Relay Contacts	Zone 1 - 1 Pole Normally Open - 8 A @ 250 VAC Zone 2 - 1 Pole Normally Open - 8 A @ 250 VAC
Sensor Inputs	Up To 8 NTC Thermistors
Sensor Supply	24 VDC - 100 mA Maximum
Terminals	Power: 4 mm <sup>2</sup> - 14 AWG Maximum Signals: 2.5 mm <sup>2</sup> - 16 AWG Maximum
Dimensions (H x W x D)	9.7 x 7.4 x 4 (inches) / 246 x 188 x 102 (mm)
Fixing Centres (H x W)	8.75 x 4 (inches) / 222 x 102 (mm)
Cable Entry	2 Holes 1-1/8 in. Diameter (28 mm) - 3/4 in. Conduit
Weight	3 lbs / 1.3 Kg
LED Status Indicators	Green LED - Power Green LED - Hot Bearing #1 through #8 Red LED - Alarm
Push Buttons	Mute Test
Approvals	<ul style="list-style-type: none"><li>• CSA - Class II Div. 2, Groups F &amp; G (T4004NV46C)</li><li>• CSA - Class II Div. 1, Groups E, F &amp; G (T4004NV4C - When Powered with a Class 2 Power Supply)</li></ul>

## WARNING

The unit should ONLY be powered with either a main supply (V46C model) OR a 24 VDC (V4C and V46C models) NOT BOTH.

# OPERATION

## TEMPERATURE SENSORS -

The T400N may be operated with any 4B 2 wire NTC sensor. Please contact 4B for the full range of sensors available.

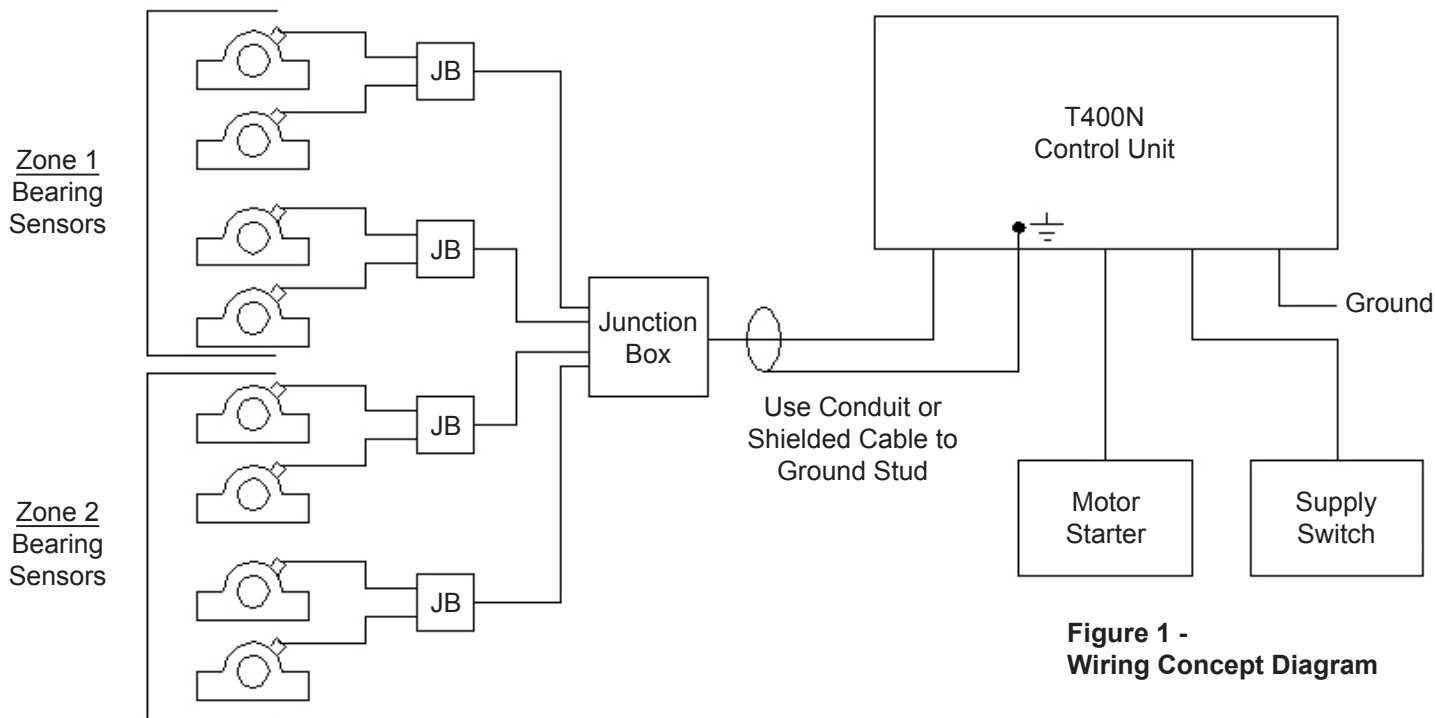

Figure 1 -  
Wiring Concept Diagram

## ZONING -

The T400N has 2 independent alarm and stop relays; alarm relay A and B and stop relay A and B. The reason is that the T400N may monitor and control a single machine or two separate machines. The T400N allows connection of up to 8 NTC sensors.

### Zone 1 -

Sensor inputs 1 to 4 are classed as Zone 1 and are associated with Alarm Relay A and Stop Relay A

### Zone 2 -

Sensor inputs 5 to 8 are classed as Zone 2 and are associated with Alarm Relay B and Stop Relay B. The connections for the T400N are shown in Figure 2.

### Combining Zones for Single 8 Sensor Zone -

If a single zone is required then up-to 8 NTC sensors may be used. If this arrangement is desired then alarm relay A & B must be wired in parallel and stop relay A & B must be wired in series.

## USER DISPLAY -

The front panel provides a single power green LED to show that the unit is powered. Each sensor input has its own green status LED. Under normal operation (when the sensor is below its trip point) the green status LED will be OFF. When an alarm occurs the green status LED will be on and the red alarm LED will flash.

## ALARM RELAY & ALARM CONDITIONS -

The alarm relays are normally de-energized and will energise when an alarm is raised. The T400N will generate an alarm for the following conditions:

1. Sensor Open Circuit
2. Sensor Short Circuit
3. Sensor Above Set Trip Point

If an alarm occurs then the LED associated with that sensor input will be indicated on the front panel of the T400N. The alarm relay associated with that sensor input will be energized after two seconds.

## TEMPERATURE ALARM SETTINGS -

All 8 sensors share a common temperature trip point. The trip point is selected by the rotary switch (SW100) shown in Figure 2. The position of the rotary switch represents the following trip points given in Table 1.

Rotary Switch Position	Temperature (°F)	Temperature (°C)
0	110 ±5%	43 ±5%
1	120 ±5%	49 ±5%
2	130 ±5%	54 ±5%
3	140 ±5%	60 ±5%
4	150 ±5%	65 ±5%
5	160 ±5%	71 ±5%
6	170 ±5%	77 ±5%
7	180 ±5%	82 ±5%

**TABLE 1 -  
Temperature Trip Point  
Rotary Switch Settings**

## UNUSED SENSOR INPUTS -

If no sensor is connected to an input then the T400N needs to know that is what you have intended and not that the sensor has become open circuit. In this case unused sensor inputs should be wired to either terminal 17 or 18 (Figure 2)

## STOP CONDITIONS -

If an alarm condition persists on any one of the zones, then this will lead to a stop condition which results in the machine being shutdown. The time delay between alarm detection and shutdown is user selectable by using dip switch (SW1) as shown in Figure 2. Table 2 represents the delay settings allowed for stop relay.

Switch Setting	Delay (Seconds)
1	0
2	20
3	40
4	60
5	80
6	100
7	120
8	140

**TABLE 2 -  
Stop Relay  
Delay Settings**

## MUTE BUTTON OPERATION -

If an alarm is raised in any of the two zones, the alarm can be muted by pressing the green MUTE button on the front LID. This will turn off the alarm for that zone. If the alarm lamp and alarm relay are energized because of a hot bearing, the alarm may be muted (turned off) by the following methods. If a finger presses the MUTE button, the alarm lamp begins to flash, the alarm relay de-energizes and all hot bearing indicator lamps which were illuminated will flash. Alternatively, if 24 VDC voltage is applied across the mute input terminals (19 and 20), the same mute action will occur. If the hot bearing sensors in alarm become 'cold', the flashing indicator lamps will de-energise. If, during a mute condition, a further bearing sensor becomes 'hot', the associated hot bearing indicator lamp will illuminate, the alarm lamp and relay will energise leaving the original muted hot bearing indicator lamps flashing. A further mute operation would flash all associated hot bearing indicator lamps. The mute functionality works for both zones simultaneously.



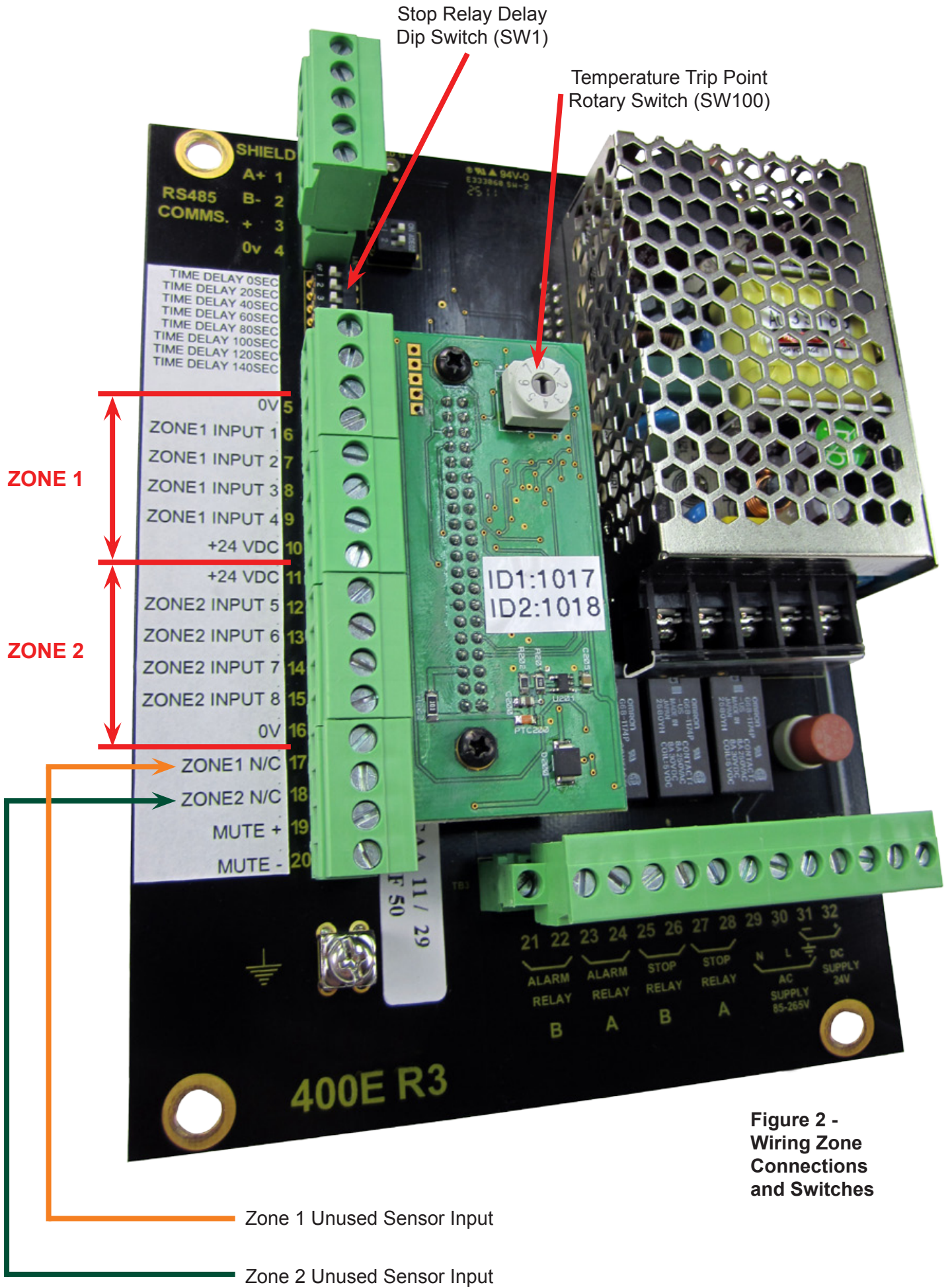

Figure 2 -  
Wiring Zone  
Connections  
and Switches

## **WARNING**

Make sure that the machine is empty of material prior to performing an extended test.

### **TEST BUTTON OPERATION -**

In order to test the T400N, press the yellow TEST button on the front lid. There are two types of tests available:

#### *Normal Test (No Machine Shutdown) -*

In order to test the correct functionality of microprocessor and illuminating lamps, a normal test can be performed. This test can be performed when the system is running or stopped.

Test Method: When the TEST button is pressed, sensor 7 lamp flashes and then the following automatic test is initiated as the touch is released.

1. All lamps illuminate – sensor 7 lamp continues to flash
2. After 5 seconds all lamps return to their pre-test conditions

#### *Extended Test (Machine Shutdown) -*

Extended test can be performed to test all the relays, illuminating lamps and microprocessor operation.

Test Method: After the normal test is initiated (given in previous section) and if the TEST button is pressed again, while sensor 7 lamp is flashing, the extended test operates as follows:

1. All lamps illuminate - sensor 7 lamp continues to flash
2. Touching the test button again
3. Sensor 7 and 8 lamps flash together for a further 5 seconds (8 seconds total time)
4. The alarm relay and stop relay for both the zones are inverted (off becomes on and on becomes off) and sensor 7, sensor 8 and the alarm led flash together.
5. After 3 seconds all lamps and relays return to their pre test conditions.

If this test is performed when the system is not running, the Alarm will sound but the stop relays will have no effect on the equipment. If this test is performed when the equipment is running, the alarm will sound and the stop relays will stop the equipment! This test should be performed on a regular basis to check the safety of the installation.

### **RS485 DATA MONITORING -**

For remote data viewing and accessibility, the user can communicate with the T400N over an RS485 network by using PLC protocols.

For detailed information regarding the packet structure for the RS485 please refer to the RS485 PROTOCOL section found in this manual.

## **ELECTRICAL CONNECTION**

All electrical connections are made via 3 sets of terminals provided as shown in Figure 3.

### **FUSE RATINGS -**

It is very important to observe the fuse ratings used on the T400N Elite.

The following fuse ratings **MUST** apply.

- F5 has a maximum rating of 2 A (T4004NV46C) or 200 mA (T4004NV4C)
- F5 is used to limit the current available to the internal electronics and terminals 3 and 4
- F6 is used to protect the AC power supply and should have a 2 A rating (T4004NV46C only)

**Figure 3 -  
T400N Wiring  
Connections**

**RS485 CONNECTION DETAILS**

- Terminal 1 - A+
- Terminal 2 - B-
- Terminal 3 - 24 VDC
- Terminal 4 - 0 Volt

**FIELD WIRING CONNECTION DETAILS**

- Terminal 5 - 0 Volt Connection
- Terminal 6 - Temperature Sensor 1 Input
- Terminal 7 - Temperature Sensor 2 Input
- Terminal 8 - Temperature Sensor 3 Input
- Terminal 9 - Temperature Sensor 4 Input
- Terminal 10 - 24 VDC Power to Temperature Sensors (Protected by F5)
- Terminal 11 - 24 VDC Power to Temperature Sensors (Protected by F5)
- Terminal 12 - Temperature Sensor 5 Input
- Terminal 13 - Temperature Sensor 6 Input
- Terminal 14 - Temperature Sensor 7 Input
- Terminal 15 - Temperature Sensor 8 Input
- Terminal 16 - 0 Volt Connection
- Terminal 17 - Termination for Unused Sensor Inputs
- Terminal 18 - Termination for Unused Sensor Inputs
- Terminal 19 - Remote MUTE+ Connection
- Terminal 20 - Remote MUTE- Connection

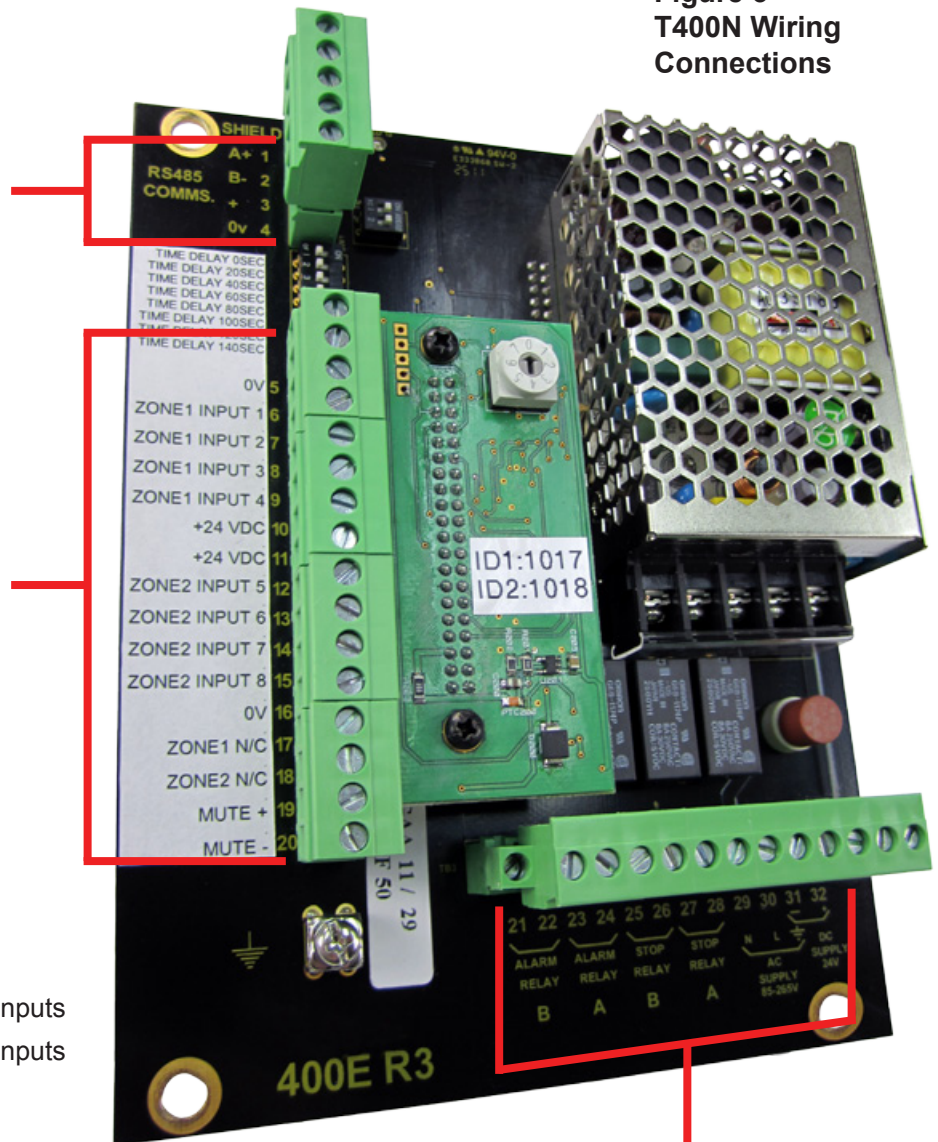

**POWER & RELAY CONNECTION DETAILS**

- Terminal 21 - Alarm B Relay Common
- Terminal 22 - Alarm B Relay Normally Open
- Terminal 23 - Alarm A Relay Common
- Terminal 24 - Alarm A Relay Normally Open
- Terminal 25 - Stop B Relay Common
- Terminal 26 - Stop B Relay Normally Closed (Under Normal Running Conditions)
- Terminal 27 - Stop A Relay Common
- Terminal 28 - Stop A Relay Normally Closed (Under Normal Running Conditions)
- Terminal 29 - Neutral Connection
- Terminal 30 - Live Connection
- Terminal 31 - Ground or 0 Volt Connection
- Terminal 32 - 24 VDC Connection

**⚠ WARNING**

The unit should ONLY be powered with either a main supply (V46C model) OR a 24 VDC (V4C and V46C models) NOT BOTH.

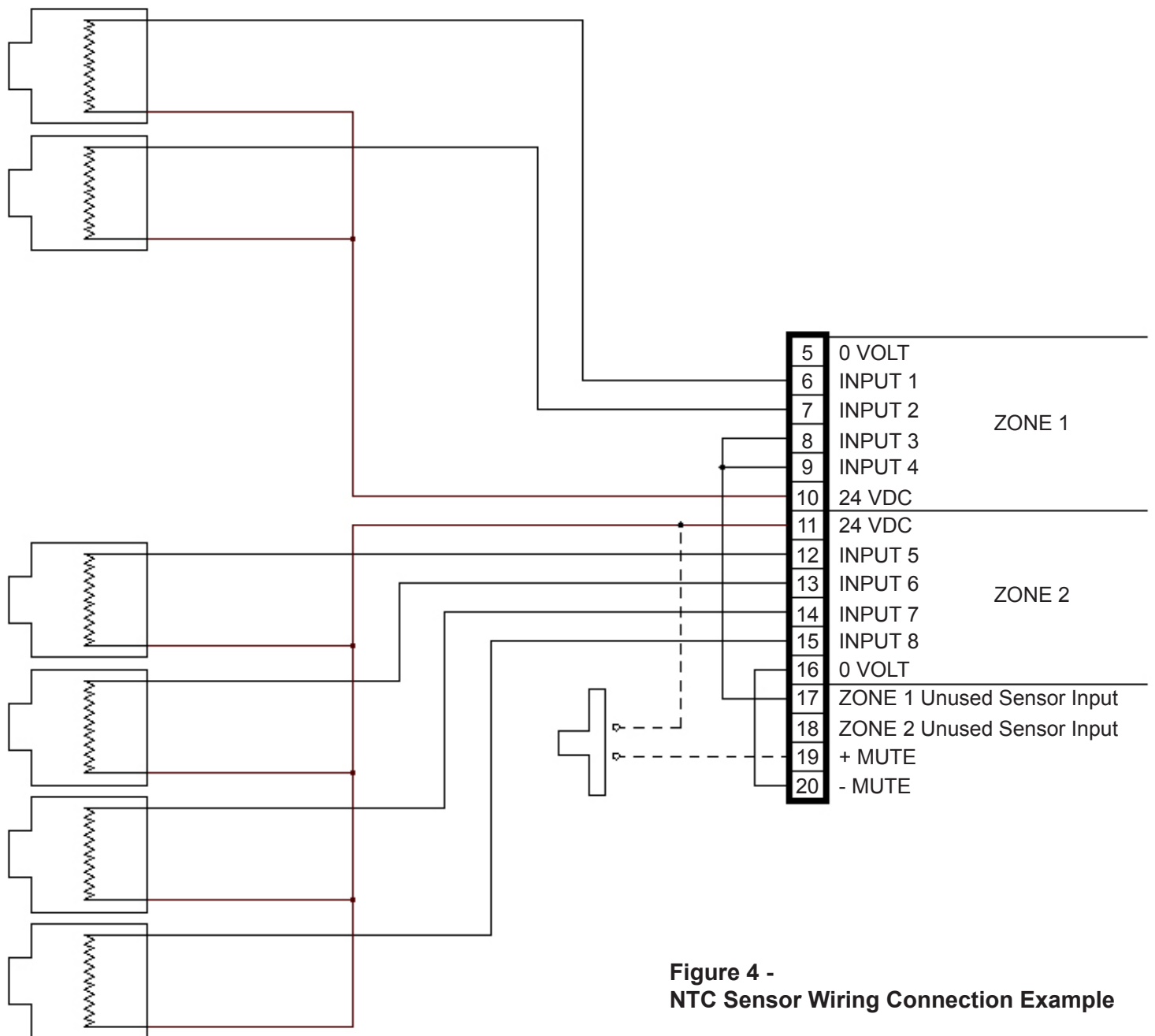
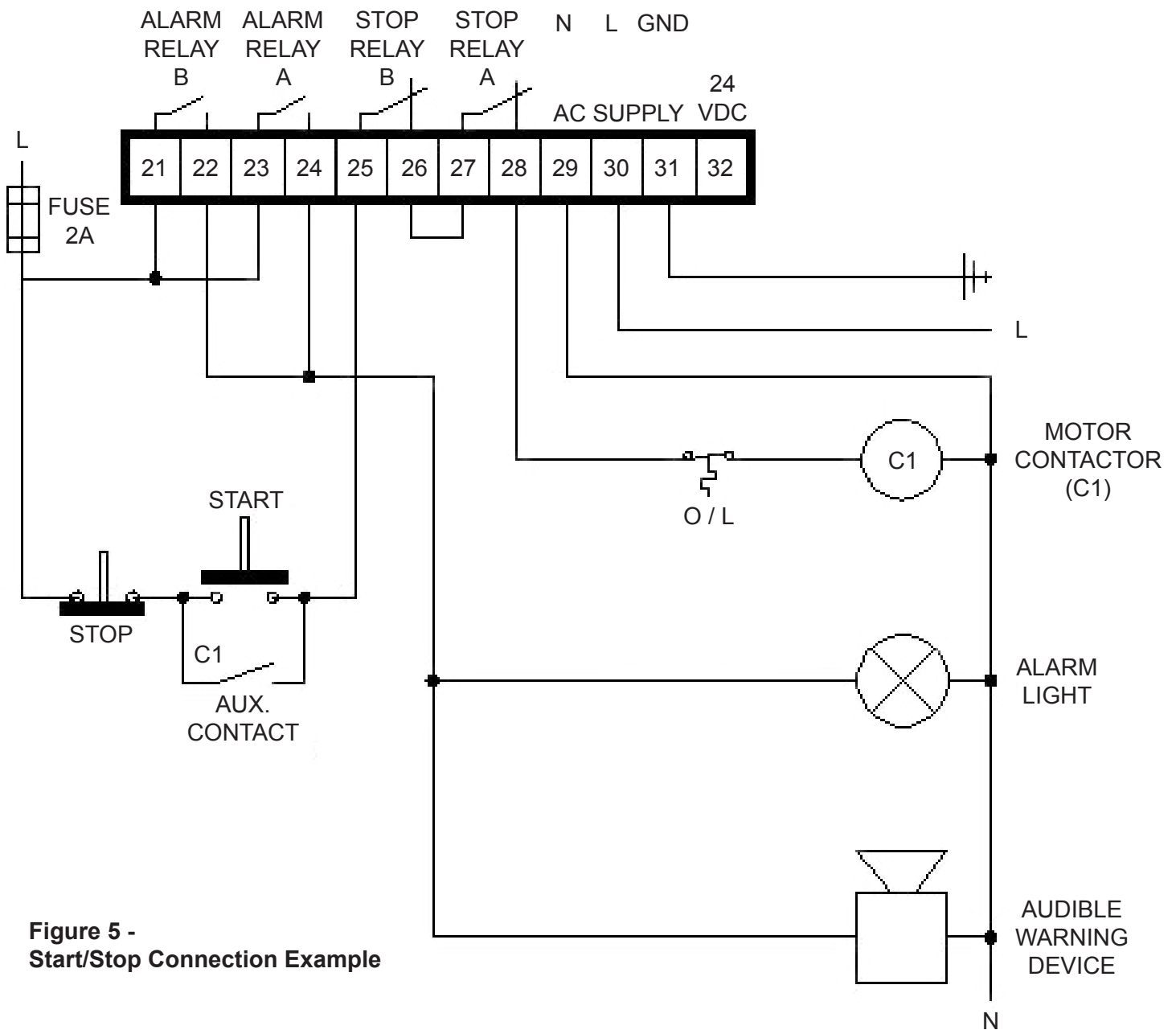

**Figure 4 -  
NTC Sensor Wiring Connection Example**

Figure 4 shows the connection of 2 NTC temperature sensors to zone 1 inputs 1 and 2.

In Figure 4, note the following connections:

- Inputs 3 and 4 are unused and are wired to terminal 17.
- All sensor inputs for zone 2 are used.
- A remote MUTE button (non-latching) is wired.



**Figure 5 - Start/Stop Connection Example**

Figure 5 is an example showing a conventional start/stop circuit wired for driving the motor contactor. In this case, the stop relays are wired in series and the alarm relays are wired in parallel.

This example also assumes a mains coil on the contactor. A 24 VDC supply may be used for the start/stop circuit if a DC contactor coil is used.

# RS485 PROTOCOL

The user can communicate with T400N over RS485 network by using simple PLC protocol. Every T400N slave on the RS485 network has 2 byte address (0 - 65535).

This protocol is developed to ease interfacing of PLC systems with T400N Elite. In order to communicate with the slave (T400N), the master sends a 5 byte packet to the slave and the slave responds with the complete status of all the 8 sensors (sensor used/not used, sensor status, sensor temperature and alarm temperature) as part of a single packet which consists of 25 bytes.

On the T400N plug-in board you would find two addresses in decimal format (ID1: xxxx and ID2: xxxx).

When using the simple PLC protocol, ID1 is to be used in order to communicate with the device. ID1 needs to be converted to hexadecimal value.

NOTE: When using simple PLC protocol to communicate with T400N use ID1. ID2 is reserved for future communication protocol.

## COMMUNICATON SPECIFICATIONS -

Baud Rate	19200 bps
Data Bits	8
Parity Bits	None
Stop Bit	1

## SENDING A PACKET TO T400N -

Master Tx Packet: The master sends a transmission packet to the slave which consists of 5 bytes, the breakdown of the packet is given below:

Byte 1	Byte 2	Byte 3	Byte 4	Byte 5
STX	S_ADRH	S_ADRL	CMD	ETX

- STX = Start of Transmission (0x02)
- S\_ADRH = Slave Address High Byte
- S\_ADRL = Slave Address Low Byte
- CMD = Command Byte
- ETX = End of Transmission (0x03)

At the start of the packet the master needs to insert 0x02, followed by the high and low bytes of the slave address.

CMD contains information about the requested data (1 = request data in C, 2 = request data in F).

The packet finishes with the end of transmission byte 0x03.

## MASTER RECEIVE PACKET -

The slave responds back with the packet that consists of 25 bytes. The breakdown of the received packet is given below:

Byte 1	Byte 2	Byte 3	Byte 4	Byte 5	Byte 6	Byte 7	Byte 8 - Byte 23	Byte 24	Byte 25
STX	S_ADRH	S_ADRL	CMD	S_EN	S_STAT_H	S_STAT_L	NTC TEMP	SET_TEMP	ETX

- STX = Start of Transmission (0x02)
- S\_ADRH = Slave Address High Byte
- S\_ADRL = Slave Address Low Byte
- CMD = Command Byte
- S\_EN = Sensors Used or Not
- S\_Stat\_H = Sensor Status High Byte
- S\_Stat\_L = Sensor Status Low Byte
- NTC\_TEMP = Temperature of all the 8 NTC Sensors (2 Byte per sensor)
- SET\_TEMP = Alarm Temperature Trip Point
- ETX = End of Transmission

**DECODING A RECEIVED PACKET -**

- STX = 0x02
- S\_ADRH = High Byte for the Slave Address
- S\_ADRL = Low Byte for Slave Address
- CMD = Command Byte
- S\_EN = A single byte containing information as to how many sensors are used. All the unused sensors should be tied to specified terminals (terminal 17, terminal 18) on the T400N Board.

Description of each bit in S\_EN byte is given below:

S_EN (Bits)	MSB (B7)	B6	B5	B4	B3	B2	B1	LSB (B0)
SENSOR	8	7	6	5	4	3	2	1

- Bit = 0, Sensor not used, sensor is tied to terminal 17 or terminal 18 of T400N
- Bit = 1, Sensor used, it is intended to use the sensor
- S\_Stat\_H and S\_Stat\_L = Two bytes contain the status of each sensor, and two bits are used per sensor in order to indicate the status of sensor.

The following table describes the bit combination that represents temperature:

00	Normal
01	Sensor Temperature Higher Than Alarm Temperature
10	Sensor Open Circuit
11	Sensor Short Circuit

The following table describes the bits used for representing status of sensors 1 to 8:

S_STAT_H (Bits)	MSB (B7)	B6	B5	B4	B3	B2	B1	LSB (B0)
SENSOR	8	8	7	7	6	6	5	5

S_STAT_L (Bits)	MSB (B7)	B6	B5	B4	B3	B2	B1	LSB (B0)
SENSOR	4	4	3	3	2	2	1	1

- NTC\_Temp (Byte 8 - Byte 23): 16 bytes to represent the temperature of eight NTC sensors. For every sensor, two bytes are used to represent the temperature
  - Byte 8 and Byte 9 contain the temperature value for sensor 8..... byte 22 and byte 23 contain the temperature reading for sensor 1
  - Byte 8 = High Byte for sensor 8 temperature value
  - Byte 9 = Low Byte for sensor 8 temperature value
- SET\_TEMP = Alarm temperature trip point per Table 1 (°C if CMD = 1, °F if CMD = 2)
- ETX = 0x03

## **WARNING**

- Rotating machinery can cause serious injury or death
- Always lockout and tagout the machine prior to installation

## **WARNING**

The control unit is susceptible to static voltage. Connection of a ground to terminal 31 is essential for optimum performance. Prior to this connection, static handling precautions should be taken.

## **INSTALLATION INSTRUCTIONS**

All wiring must be in accordance with local and national electrical codes and should be undertaken by an experienced and qualified electrician.

Always use dust/liquid tight flexible metal conduit with approved fittings to protect the sensor cables. Use rigid metal conduit to protect the cables from the sensors to the control unit. Conduit systems can channel water due to ingress and condensation directly to sensors and sensor connections which over time will adversely affect the performance of the system. As such, the installation of low point conduit drains is recommended for all sensors.

The control unit box should be installed in a suitable control or starter switch room and mounted at an eye level position so that the warning lights can be readily seen. The box should have sufficient space to open the lid for wiring and adjustment

Enclosure Installation:

1. You must use the correct cable, glands and sealing arrangement and in accordance with all installation codes.
2. Where other certified components are used as part of the assembly or installation procedure, the user must take in to account any limitations which might be listed on the relevant certificates.
3. The box is supplied with 2 x 27.5 mm (1 $\frac{1}{8}$ "") pre drilled holes in the bottom face. All unused entry apertures must be sealed using component certified stopping plugs. The end user must install component or apparatus certified stopping plugs and cable glands/conduit in strict accordance with the manufacturer's instructions. In order to connect conduit to the control unit enclosure, use a Myers™ hub or other equivalent fitting that is rated and suitable for the environment.
4. The enclosure must not be modified in any way, as this will invalidate the certification.
5. All wiring must be carried out in accordance with relevant codes of practice and / or instructions.
6. The voltage and current and maximum power dissipation shown on the box label must not be exceeded.
7. The wiring installation must extend to within 1 mm of the metal face of the terminal.
8. All leads must be insulated for the appropriate voltage.
9. Not more than 1 single or multiple strand cable is to be connected to any terminal unless multiple conductors have previously been joined in a suitable manner (e.g. boot lace ferrule) such that they present a single connection point to the terminal.
10. A flat-head or straight screwdriver of the correct size should always be used when tightening terminals.



# TROUBLESHOOTING GUIDE

FAULT	CAUSE	REMEDY
Unused sensor(s) alarming	The sensor input is an open circuit	Jumper unused inputs to “unused sensor” terminal on corresponding zone
Sensors are in alarm	The bearing is hot	Perform maintenance / replace bearing
	The sensor is mis-wired	Check for any short circuits, disconnected wires, or broken wires
1. The power LED does not light up 2. No 24 VDC on terminals 3. Stop relay will not energize	Fuse F5 or F6 is blown	Correct wiring issues and replace F5 or F6 fuse
Machine is shutting down faster than configured time delay	Multiple switches are turned on at the time delay switch	Select only one timer setting



# PRODUCT WARRANTY

## 1. EXCLUSIVE WRITTEN LIMITED WARRANTY

ALL PRODUCTS SOLD ARE WARRANTED BY THE COMPANY (4B COMPONENTS LIMITED, (4B) BRAIME ELEVATOR COMPONENTS LIMITED, AND (4B) S.E.T.E.M. Sarl HEREIN AFTER REFERRED TO AS 4B TO THE ORIGINAL PURCHASER AGAINST DEFECTS IN WORKMANSHIP OR MATERIALS UNDER NORMAL USE FOR ONE (1) YEAR AFTER DATE OF PURCHASE FROM 4B. ANY PRODUCT DETERMINED BY 4B AT ITS SOLE DISCRETION TO BE DEFECTIVE IN MATERIAL OR WORKMANSHIP AND RETURNED TO A 4B BRANCH OR AUTHORIZED SERVICE LOCATION, AS 4B DESIGNATES, SHIPPING COSTS PREPAID, WILL BE, AS THE EXCLUSIVE REMEDY, REPAIRED OR REPLACED AT 4B'S OPTION.

## 2. DISCLAIMER OF IMPLIED WARRANTY

NO WARRANTY OR AFFIRMATION OF FACT, EXPRESSED OR IMPLIED, OTHER THAN AS SET FORTH IN THE EXCLUSIVE WRITTEN LIMITED WARRANTY STATEMENT ABOVE IS MADE OR AUTHORIZED BY 4B. 4B SPECIFICALLY DISCLAIMS ANY LIABILITY FOR PRODUCT DEFECT CLAIMS THAT ARE DUE TO PRODUCT MISUSE, ABUSE OR MISAPPLICATIONS, AS AUTHORIZED BY LAW, 4B SPECIFICALLY DISCLAIMS ALL WARRANTIES THAT THE PRODUCT IS FIT OR MERCHANTABILITY FOR A PARTICULAR PURPOSE.

## 3. NO WARRANTY "BY SAMPLE OR EXAMPLE"

ALTHOUGH 4B HAS USED REASONABLE EFFORTS TO ACCURATELY ILLUSTRATE AND DESCRIBE THE PRODUCTS IN ITS CATALOGS, LITERATURE, AND WEBSITES, SUCH ILLUSTRATIONS AND DESCRIPTIONS ARE FOR THE SOLE PURPOSE OF PRODUCT IDENTIFICATION AND DO NOT EXPRESS OR IMPLY A WARRANTY AFFIRMATION OF FACT, OF ANY KIND OR A WARRANTY OR AFFIRMATION OF FACT THAT THE PRODUCTS WILL CONFORM TO THEIR RESPECTIVE ILLUSTRATIONS OR DESCRIPTIONS. 4B EXPRESSLY DISCLAIMS ANY WARRANTY OR AFFIRMATION OF FACT, EXPRESSED OR IMPLIED, OTHER THAN AS SET FORTH IN THE EXCLUSIVE WRITTEN LIMITED WARRANTY STATEMENT ABOVE, INCLUDING, WITHOUT LIMITATION, THE IMPLIED WARRANTIES OF MERCHANTABILITY AND FITNESS FOR A PARTICULAR PURPOSE.

## 4. LIMITATION OF DAMAGES

ANY LIABILITY FOR CONSEQUENTIAL, INCIDENTAL, SPECIAL, EXEMPLARY, OR PUNITIVE DAMAGES, OR FOR LOSS OF PROFIT WHETHER DIRECT OR INDIRECT, IS EXPRESSLY DISCLAIMED.

With subsidiaries in North America, Europe, Asia, Africa and Australia along with a worldwide network of distributors, 4B can provide practical solutions for all your applications no matter the location.



**4B BRAIME ELEVATOR COMPONENTS**

Hunslet Road  
Leeds LS10 1JZ  
UK  
Tel: +44 (0) 113 246 1800  
Fax: +44 (0) 113 243 5021

**4B DEUTSCHLAND**

9 Route de Corbie  
Lamotte Warfusee  
F-8080  
France  
Tel: +49 (0) 700 2242 4091  
Fax: +49 (0) 700 2242 3733

**4B ASIA PACIFIC**

68/19 Moo 5  
Tambol Bangmuangmai  
Amphur Muang Samutprakarn  
10270  
Thailand  
Tel: +66 (0) 2 758-3648  
Fax: +66 (0) 2 758-2926

**4B COMPONENTS LTD.**

625 Erie Ave.  
Morton, IL 61550  
USA  
Tel: 309-698-5611  
Fax: 309-698-5615

**4B SETEM SARL**

9 Route de Corbie  
80800 Lamotte Warfusee  
France  
Tel: +33 (0) 3 22 42 32 26  
Fax: +33 (0) 3 22 42 37 33

**4B AFRICA**

PO Box 1489  
Jukskei Park  
2153 Johannesburg  
South Africa  
Tel: +27 (0) 11 708 6114  
Fax: +27 (0) 11 708 1654

**4B AUSTRALIA**

Unit 1-18  
Overlord Place, Acacia Ridge  
Queensland 4110  
Australia  
Tel: +61 (0) 7 3711 2565  
Fax: +61 (0) 7 3711 2574

[www.go4b.com](http://www.go4b.com)