



**F500 Elite.**

**FIELDBUS ADAPTER.**

**Watchdog NTC to Profibus DP  
communications.**

**(Software Version 9.5.x)**

**Approvals: Suitable for use in Hazardous Locations**

**CL II Div 1 GPS E, F & G (V4)**

When powered with a Class2 power supply.

**CL II Div 2 GPS F & G (V46)**

# CONTENTS

## INTRODUCTION

- 1 SPECIFICATIONS
- 2 INSTALLATION INSTRUCTIONS
- 3 ELECTRICAL WIRING
- 4 OPERATING INSTRUCTIONS

## FAULT FINDING

## CONTACT INFORMATION

## DRAWINGS

- A CONNECTING THE F500 ELITE TO AN AC SUPPLY
- B CONNECTING THE F500 ELITE TO A DC SUPPLY
- C F500 ELITE TO WATCHDOG ELITE CONNECTIONS
- D F500 ELITE TO VT100 SERIAL TERMINAL CONNECTIONS
- E GENERAL CONNECTION DETAIL

## APPENDIX A – SETTING THE MODULE SWITCHES



Dear 4B Customer:

Congratulations on your purchase. 4B appreciates your business and is pleased you have chosen our products to meet your needs.

Please read in its entirety and understand the literature accompanying the product before you place the product into service. Please read the safety precautions carefully before operating the product. With each product you purchase from 4B, there are some basic but important safety considerations you must follow to be sure your purchase is permitted to perform its design function and operate properly and safely, giving you many years of reliable service. Please read and understand the Customer Safety Responsibilities listed below. Failure to follow this safety directive and the Operation Manuals and other material furnished or referenced, may result in serious injury or death.

### ***SAFETY NOTICE TO OUR CUSTOMERS***

- A. In order to maximize efficiency and safety, selecting the right equipment for each operation is vital. The proper installation of the equipment, and regular maintenance and inspection is equally important in continuing the proper operation and safety of the product. The proper installation and maintenance of all our products is the responsibility of the user unless you have asked 4B to perform these tasks.
- B. All installation and wiring must be in accordance with Local and National Electrical Codes and other standards applicable to your industry. (Please see the article "Hazard Monitoring Equipment Selection, Installation and Maintenance" at [www.go4b.com](http://www.go4b.com).) The installation of the wiring should be undertaken by an experienced and qualified professional electrician. Failure to correctly wire any product and/or machinery can result in the product or machine failing to operate as intended, and can defeat its design function.
- C. Periodic inspection by a qualified person will help assure your 4B product is performing properly. 4B recommends a documented inspection at least annually and more frequently under high use conditions.
- D. Please see the last page of this manual for all warranty information regarding this product.

### ***CUSTOMER SAFETY RESPONSIBILITIES***

#### **1. READ ALL LITERATURE PROVIDED WITH YOUR PRODUCT**

Please read all user, instruction and safety manuals to ensure that you understand your product operation and are able to safely and effectively use this product.

#### **2. YOU BEST UNDERSTAND YOUR NEEDS**

Every customer and operation is unique, and only you best know the specific needs and capabilities of your operation. Please call the 24-hour hotline at 309-698-5611 for assistance with any questions about the performance of products purchased from 4B. 4B is happy to discuss product performance with you at any time.

**3. SELECT A QUALIFIED AND COMPETENT INSTALLER**

Correct installation of the product is important for safety and performance. If you have not asked 4B to perform the installation of the unit on your behalf, it is critical for the safety of your operation and those who may perform work on your operation that you select a qualified and competent electrical installer to undertake the installation. The product must be installed properly to perform its designed functions. The installer should be qualified, trained, and competent to perform the installation in accordance with Local and National Electrical Codes, all relevant OSHA Regulations, as well as any of your own standards and preventive maintenance requirements, and other product installation information supplied with the product. You should be prepared to provide the installer with all necessary installation information to assist in the installation.

**4. ESTABLISH AND FOLLOW A REGULAR MAINTENANCE AND INSPECTION SCHEDULE FOR YOUR 4B PRODUCTS**

You should develop a proper maintenance and inspection program to confirm that your system is in good working order at all times. You will be in the best position to determine the appropriate frequency for inspection. Many different factors known to the user will assist you in deciding the frequency of inspection. These factors may include but are not limited to weather conditions; construction work at the facility; hours of operation; animal or insect infestation; and the real-world experience of knowing how your employees perform their jobs. The personnel or person you select to install, operate, maintain, inspect or perform any work whatsoever, should be trained and qualified to perform these important functions. Complete and accurate records of the maintenance and inspection process should be created and retained by you at all times.

**5. RETAIN AND REFER TO THE OPERATION MANUAL FOR 4B'S SUGGESTED MAINTENANCE AND INSPECTION RECOMMENDATIONS**

As all operations are different, please understand that your specific operation may require additional adjustments in the maintenance and inspection process essential to permit the monitoring device to perform its intended function. Retain the Operation Manual and other important maintenance and service documents provided by 4B and have them readily available for people servicing your 4B equipment. Should you have any questions, please call the 4B location who supplied the product or the 24-hour hotline number in the USA -309-698-5611.

**6. SERVICE REQUEST**

If you have questions or comments about the operation of your unit or require the unit to be serviced please contact the 4B location who supplied the product or send your request via fax (309-698-5615), email (4b-usa@go4b.com), or call us via our 24-hour hotline number in the USA - 309-698-5611. Please have available product part numbers, serial numbers, and approximate date of installation. In order to assist you, complete the following information after the product has been placed into service and fax this page to 309-698-5615.

SITE NAME:
SITE LOCATION:
CONTACT NAME:
CONTACT NUMBER:
PART NUMBER:
SERIAL NUMBER:
DATE OF INSTALL:

# **F500 FIELDBUS ADAPTER.**

## **INTRODUCTION**

This version of the F500 Elite Fieldbus adapter had been designed to work as a Watchdog Elite communications gateway and has been designed specifically to allow up to 7 Watchdog NTC control units to be networked together through their own built in communications system. The network data can then be passed through the Fieldbus adapter to a Profibus DP network. The communications control unit is housed in a self-contained wall-mounting enclosure, and will operate from 100-240v AC or from 24v DC.

## **1. SPECIFICATIONS**

### **1.1 The Control Unit**

A plastic enclosure houses the electronics and terminal connectors. The unit contains a printed circuit board to accommodate power supply circuitry, microprocessor, Fieldbus card and terminals. The design is capable of accommodating 8 of the most common Fieldbus interfaces.

Electrical Supply	-	100-240VAC +/- 10% 50/60Hz
	-	24VDC +/- 10%
Power Consumption	-	12 WATTS
Terminals	-	Power 4mm <sup>2</sup> 14 AWG max
	-	Communications, as appropriate to the Fieldbus module.
Protection	-	NEMA4X,IP66
Height	-	9.7", 246mm
Width	-	7.4", 188mm
Depth	-	4", 102mm
Fixing Centres	-	8.75" high x 4" wide, 222mm x 102mm
Cable Entry	-	2 Holes 1 1/8" DIA, 28mm, 3/4" CONDUIT
Weight	-	3lbs, 1.3Kg

**Approvals: Suitable for use in Hazardous Locations**

**CL II Div 1 GPS E, F & G (V4)**

When powered with a Class2 power supply.

**CL II Div 2 GPS F & G (V46)**

## 2. INSTALLATION INSTRUCTIONS

### The Control Unit

The Control Unit box should be installed in a suitable control or starter switch room. The box should have sufficient space to open the lid for wiring.



**The Control Unit is susceptible to static voltage. Connection of a clean ground to terminal 29 is essential for optimum performance. Prior to this connection, static handling precautions should be taken.**

## 3 ELECTRICAL WIRING

Refer to Drawings A, B, C & E

When installing the equipment in an area which is likely to be hazardous from Ignitable Dusts, use liquid tight conduit and fittings and follow all local codes.

## 4 OPERATING INSTRUCTIONS

The Fieldbus Adapter is a self contained unit and there are a number of user configurable options. The adapter is equipped with three communications ports; RS232, RS485 and Profibus DP.

The RS232 is a simple interface which can be used for diagnostics purposes. The data from this port is formatted to work with a VT100 display terminal. Any terminal or terminal emulator capable of supporting the VT series or compatible commands can be used with this port although the data has been optimised to work with VT100. The RS232 port operates at a fixed data rate of 9600, N, 8, 1.

The RS485 port is a four wire, twin twisted pair full duplex serial port and has been specifically configured to work with the Watchdog communications network. You should not connect any other devices to this port unless you wish to monitor the Watchdog data directly. If this is the case then contact your supplier for details relating to the Watchdog communications protocol.

*The Profibus interface provides the following:*

Transmission media: Profibus bus line, type A or B specified in EN50170

Topology: Slave configuration

Fieldbus Connector: 9 pin female DSUB

Cable: shielded copper; twisted pair

Optically isolated bus A and B termination

Address range 1-99 selected by on board switch

Maximum cyclic I/O data size of 244 bytes

Optional bus termination, switch selectable

Led status indication

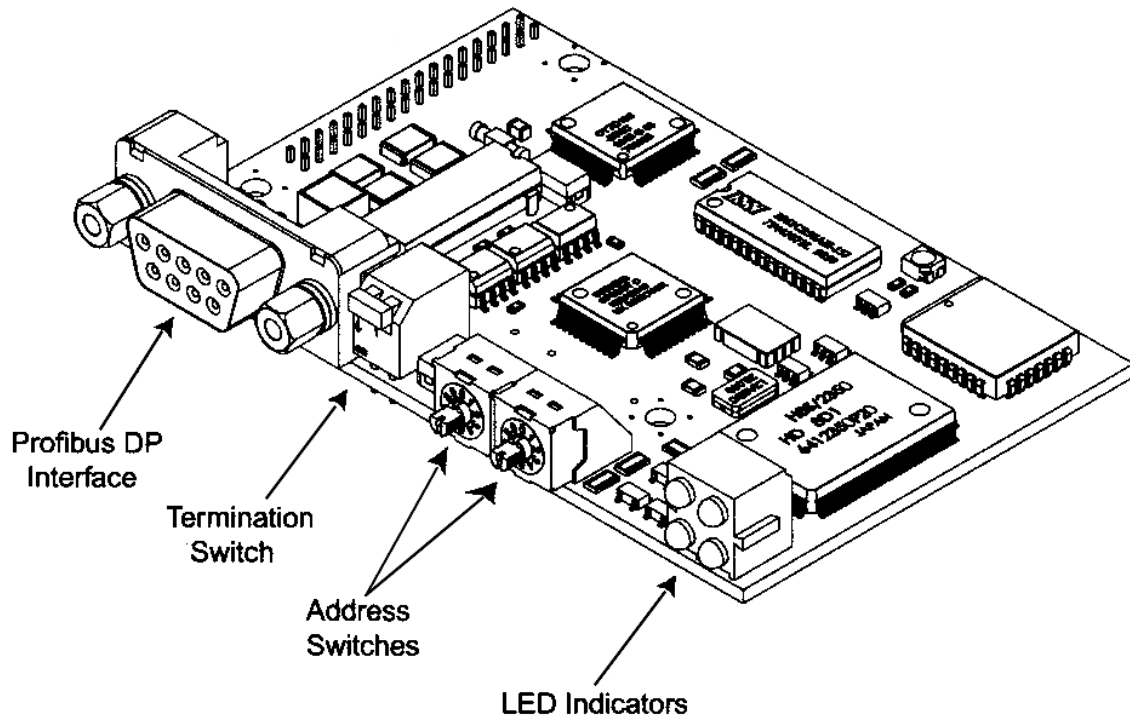

The above diagram shows the location of the main parts of the Profibus module.

The address switches allow the unit slave address to be set between 01 and 99. The left hand switch sets the ten's digit of the address and the right hand switch sets the unit digit of the address. If you decide to change the address then you must reset the interface by first removing and then reconnecting power. The default unit address is 77.

The termination switch can be used to add termination resistors to the Profibus interface if required. If the F500 Profibus interface card is the first or last module on the Profibus network, then the switch needs to set to ON, otherwise it must be set to OFF.

The Profibus connections are shown below and are identical to the standard Profibus DSUB connections.

Pin	Signal	Description.
1	N/C	No connection
2	N/C	No connection
3	B line	Positive RxD/TxD according to RS485 specification
4	RTS	Request to send
5	GND BUS	Isolated ground connection
6	+5V BUS	Isolated +5V connection
7	N/C	No Connection
8	A line	Negative RxD/TxD according to RS485 specification
9	N/C	No Connection

The status LED's are grouped in a single block of four and indicate the following status.

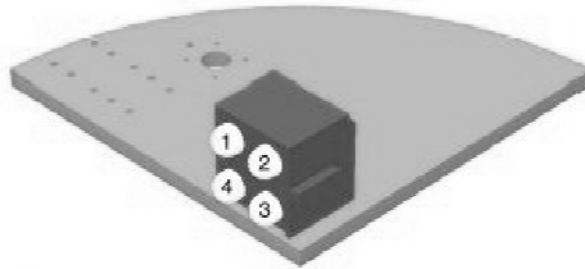

#### Led 1 Status

<i>Colour</i>	<i>Frequency</i>	<i>Description</i>
-	-	Not Used

#### Led 2 Status

<i>Colour</i>	<i>Frequency</i>	<i>Description</i>
Green	Solid on	Module is ON-LINE and data exchange is possible

#### Led 3 Status

<i>Colour</i>	<i>Frequency</i>	<i>Description</i>
Red	Solid on	Module is OFF-LINE and data exchange is not possible.

#### Led 4 Status

<i>Colour</i>	<i>Frequency</i>	<i>Description</i>
Red	1 Hz	Interface board initialisation failure
Red	2 Hz	Network configuration does not match module configuration
Red	4 Hz	Initialisation failure of the Profibus interface IC



**Input register data map** (Cyclic I/O data transfer – Max 244 bytes see page, see Appendix A for more information).

The Watchdog data is automatically read for up to 7 controllers. The data returned is processed and stored in the following format. The position of the data is fixed within the input data table.

Watchdog Address	Input Words	Input Byte
-	0	0-1
1	1 – 17	2 – 35
2	18 – 34	36 – 69
3	35 – 51	70 -104
4	52 – 68	105 -137
5	69 – 85	138 -171
6	86 – 102	172 - 205
7	103 – 119	206 - 239

The Watchdog data is automatically read for up to 7 controllers. The data returned is processed and stored in the following format. The position of the data is fixed within the input data table.

Word 0 (Byte 1) is used to indicate the number of Watchdogs that are responding to the request for data. Word 0 (Byte 0) is unused. This only occurs once in the entire table. The remaining data stored in the input bytes is constructed as follows.

All the values are stored in Hexadecimal and Word aligned in this example

Number of Watchdogs detected this time (Byte 1,0) Once only	0	No.Of WD	0x0200
Watchdog current speed (Byte 3,2)	1	WD1 Speed	0x0000
Watchdog current operating status (Byte 5,4)	2	Status	0x0000
Under speed alarm and stop in % (Byte 7,6)	3	USA/USS	0x0000
Over speed alarm and stop in % (Byte 9,8)	4	OSA/OSS	0x0000
Current calibration value in PPM (Byte 11,10)	5	Calibration PPM	0x0000
Display scaling factor (Byte 13,12)	6	Scale Factor	0x0000
NTC Temperature 1 and 2 (Byte 15, 14)	7	T1/T2	0x0000
NTC Temperature 3 and 4 (Byte 17, 16)	8	T3/T4	0x0000
NTC Temperature 5 and 6 (Byte 19, 18)	9	T5/T6	0x0000
NTC temperature sensor status 1 and 2 (Byte 21,20)	10	ST1/ST2	0x0000
NTC temperature sensor status 3 and 4 (Byte 23,22)	11	ST3/ST4	0x0000
NTC temperature sensor status 5 and 6 (Byte 25,24)	12	ST5/ST6	0x0000
Sensor 1 and sensor 2 alarm level (Byte 27,26)	13	ALM1/ALM2	0x0000
Sensor 3 and sensor 4 alarm level (Byte 29,28)	14	ALM3/ALM4	0x0000
Sensor 5 and sensor 6 alarm level (Byte 31,30)	15	ALM5/ALM6	0x0000
Number of sensors in use (Byte 33), Relay status (Byte 32)	16	NOS/REL	0x0000
Persistent alarm value (Byte 35), update counter (Byte 34)	17	PERALM/CNT	0x0000

The data from each Watchdog is stored in 17 consecutive words (or 34 bytes) of data.

The first two bytes of the group (e.g. word 1) represent the Watchdog speed.

The second two bytes of the group of the group (e.g. word 2) represent the Watchdog status.

The Watchdog speed is encoded in the following manner. Four hexadecimal digits are used to represent the measured speed for the Watchdog. The rightmost three and a half are the main body of the speed and the upper half of the fourth is the position of the decimal place within the information. If the most significant two bits are '00' then decoding of the speed is not required. If the two bits are '01', then the resulting value should be divided by 10 and if the two bits are '10' then the speed should be divided by 100. The top two bits should never be '11' as this has no meaning.

Bit 7	Bit 6	Description (e.g. most significant bits of the first speed byte 3)
0	0	Bits 5-0 of the first byte and the whole second represent the speed.
0	1	Same as above but the speed and should be divided by 10
1	0	Same as above but the speed and should be divided by 100
1	1	Not used.

An example of this can be seen below.

Watchdog speed = 6E (e.g. byte 3) & 1E (e.g. byte 2). The leftmost digit (6) = '0110' in binary which can be separated into '01' (bits 7 and 6) for speed scaling and '10' (bits 5 and 4) for the upper speed digit. If you strip off bits 7 and 6 you are left with a decoded value of 2E & 1E for the speed and '01' or divide by 10 for the scaling. The speed 2E1E converted to decimal = 11806 and then divided by 10 results in an actual speed of 1180.6. By default the Watchdog will display speed in pulses per minute but it can be scaled to display any value required, refer to the Watchdog manual for further detail.

The Watchdog status is encoded as described in the following manner.

Two data bytes are used to represent the status for the Watchdog. The first status byte (e.g. byte 5) is the status code and the second byte (e.g. byte 4) represents any data which is associated with the status code. All data is in hexadecimal.

Status Code (Byte 5)	Status Data (Byte 4)	What it means.
09	% Complete	Watchdog is calibrating (% complete).
0F	-	Elevator is stopped due to persistent belt slip.
10	-	Elevator is stopped due to persistent over calibration.
11	-	Misalignment detected on Top & Bottom sensors.
22	-	Elevator is stopped and is ready to run (Normal stop condition)
23	Start-up Delay In seconds	Elevator is accelerating. (xx seconds remain)
24	Speed %	Elevator running within programmed limits.
25	Speed %	Stop relay has been de-energised (Fault stop condition)
27	Time to alarm In seconds	Misalignment detected. (xx seconds to alarm)
2A	Time to alarm In seconds	Over speeding: Alarm relay about to de-energise (xx seconds to alarm)
2D	-	Misalignment detected at the top of the elevator.
2F	Time to stop	Over speeding: Stop relay about to de-energise (xx

	In seconds	seconds to stop)
31	-	Speed display is over range: check the scaling factor.
32	-	Start elevator to commence calibration procedure.
36	1-4	Watchdog has detected an internal fault.
39	Time to alarm In seconds	Belt slipping. (xx seconds to alarm)
3A	Time to stop In seconds	Belt slipping: Stop relay about to de-energise. (xx seconds to stop)
3B	-	Elevator stopped due to lack of acceleration.
3C	Time to stop In seconds	Persistent alarm. (xx seconds to alarm)
3D	-	Elevator stopped: Speed has exceeded over speed limit.
3E	-	Interlock signal off, waiting for zero speed.
3F	-	Elevator stopped: Persistent alarm condition.
40	-	Elevator stopped: Severe under speed.
41	-	Watchdog is not calibrated: Please see the manual.
42	-	Misalignment detected at the bottom of the elevator.
44	-	Wrong access code used when changing setup.
46	Speed %	Elevator speed less than alarm level (slipping)
47	Speed %	Elevator speed more than alarm level ( Over speeding)
49	-	Suspected open circuit or faulty PTC bearing temperature sensor.
4A	-	Suspected fault on one or more MAS. Could be mains pickup.
4E	-	Plug switch is open.
50	-	PTC Hot bearing at zone 1.
51	-	PTC Hot bearing at zone 2.
52	-	PTC Hot bearing at zone 3.
53	-	PTC Hot bearing at zone 4.
54	-	PTC Hot bearing at zone 5.
55	-	PTC Hot bearing at zone 6.
56	-	HBS is open circuit at zone 1
57	-	HBS is open circuit at zone 2
58	-	HBS is open circuit at zone 3
59	-	HBS is open circuit at zone 4
5A	-	HBS is open circuit at zone 5
5B	-	HBS is open circuit at zone 6

An example of the status code might be '2463'. The first status byte (byte 5) '24' show that the equipment is running within the specified alarm limits and the second status byte (byte 4) '63' indicate that the speed is 99% if it's calibrated value. Where a value is not shown or a '-' is used in the table, this indicates that any data present in this field should be ignored.

Several different conditions may occur at the same time whilst the Watchdog is operating. If the Watchdog is running within calibrated range but also detects a motion sensor fault then the information returned may look something like this.

'2463' Running at 99% of calibrated speed.

Followed three seconds later by

2D--' Misalignment detected at the top of the elevator.

Followed three seconds later by

'3CAA' Persistent alarm, 170 seconds to go.

The messages would then repeat with any new values in the status data field.

Due to some limitations in the speeds involved in updating the Watchdog information, rapid changed of data could be missed or be present for only a very short period of time.

If the Watchdog is placed in one of the two test modes, the messages below will be returned in the following order.

Bytes 3 and 2	Bytes 5 and 4	The first two bytes show the speed data and the second two bytes show the status and status data.
xx & xx	06 & xx	Over speed Stop as a percentage of calibrated speed.
xx & xx	05 & xx	Over speed Alarm as a percentage of calibrated speed.
xx & xx	02 & xx	The actual calibrated speed
xx & xx	03 & xx	Under speed Alarm as a percentage of calibrated speed.
xx & xx	04 & xx	Under speed Stop as a percentage of calibrated speed.
----	07 & --	Performing internal test.
----	4C & --	Testing the Alarm relay.
----	4D & --	Testing the Stop relay.

Codes 4C and 4D are only returned if the extended test is in operation.

#### **Under speed alarm and stop in % (Byte 7, 6)**

These two bytes show (in % of calibrated speed) the under speed alarm and stop levels. These represent the point at which the Watchdog will generate an alarm or stop condition. Example, if byte 7 is '0A' and byte 6 is '14' then this means that the Watchdog will generate an under speed alarm at 10% (0A) below calibrated speed and will generate a stop condition at 20% (14) below the calibrated speed.

#### **Over speed alarm and stop in % (Byte 9, 8)**

These two bytes show (in % of calibrated speed) the over speed alarm and stop levels. These represent the point at which the Watchdog will generate an alarm or stop condition. Example, if byte 9 is '0A' and byte 8 is '14' then this means that the Watchdog will generate an over speed alarm at 10% (0A) above calibrated speed and will generate a stop condition at 20% (14) above the calibrated speed.

### **Current calibration value in PPM (Byte 11, 10)**

These two bytes represent the current calibration speed value in Pulses Per Minute (Default). The representation can be changed to other scaled values by using the display scaling value below. Refer to the Watchdog manual for further details about display scaling.

### **Display scaling factor (Byte 13, 12)**

These two bytes contain a value which is used by the Watchdog to scale the information on the display into a format which represents more accurately what the elevator is doing. The default scaling factor (04B0) results in the display showing the current speed in PPM. Refer to the Watchdog manual for further details about display scaling.

### **NTC Temperature 1 and 2 (Byte 15, 14)**

These two bytes show the actual temperature of temperature sensors 1 & 2. The values are in Dec C or Deg F according to the settings on the Watchdog. Refer to the Watchdog manual NTC section for more detail.

### **NTC Temperature 3 and 4 (Byte 17, 16) & NTC Temperature 5 and 6 (Byte 19, 18)**

See the detail above for temperature sensors 1 and 2

### **NTC temperature sensor status 1 and 2 (Byte 21, 20)**

These two bytes show the current status of temperature sensors number 1 & 2.

If byte 21 is 0 then sensor 1 is NORMAL

If byte 21 is 1 then the temperature of sensor 1 is HIGH so an alarm has been generated.

If byte 21 is 2 then sensor 1 may be OPEN circuit

If byte 21 is 3 then sensor 1 may be SHORT circuit

**NTC temperature sensors 2 to 6 operate in an identical manner as described for sensor 1 above.**

### **Sensor 1 and sensor 2 alarm level (Byte 27,26)**

These two bytes represent the alarm value for the temperature sensor. The default values for this alarm level are '9E' (158) when measuring in Deg 'F' and '50' (80) when measuring in Deg 'C'. Refer to the Watchdog manual for further detail regarding this value.

**Sensor 3 and sensor 4 alarm level (Byte 29, 28) & Sensor 5 and sensor 6 alarm level (Byte 31, 30) operate in an identical manner as described above.**

### **Number of sensors in use (Byte 33)**

Byte 33 shows the total number of NTC temperature sensors that are currently being monitored by the Watchdog. This value ranges from 0 to 6. See the watchdog manual for further detail.

### Relay status (Byte 32)

This byte contains information relating to the status of the Watchdog LED's and Relays. Although the byte is represented in Hexadecimal converting it to binary helps to explain the contents a little better.

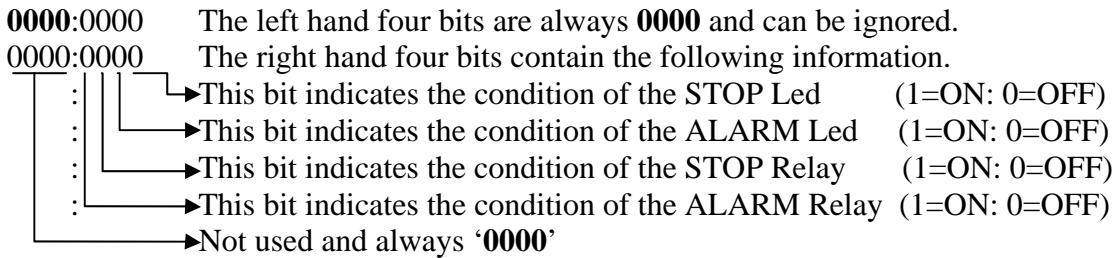

When a relay is considered to be 'ON' we mean energized and when 'OFF' we mean de-energized.

- 0000:0000 = 00 then no conditions exist
- 0000:0010 = 02 then the alarm Led is on
- 0000:1010 = 0A then the alarm Led and Alarm Relay are active
- 0000:0011 = 03 then both Led's are 'on' and both Relays are 'off' (de-energized)

### Persistent alarm value NTC only (Byte 35)

This is how long the temperature alarm will take in seconds before stopping the elevator. The default value is 'B4' 180 seconds. If this value reaches '0' then the elevator will be stopped.

### Update counter (Byte 34)

Every time the F500 successfully receives information from the chosen watchdog, then this counter value will be incremented by 1. The watchdog treats serial communications as low priority so occasionally requests for data can be ignored. It is advisable to keep checking this value so as to know when new data has arrived in the F500. The counter will increment from 0 to 255 and then return to 0 again in a continuous loop.

Below is an example of the data returned when the F500 is polling Watchdogs

	Alias	00000	Alias	00010	Alias	00020	Alias	00030	Alias	00040	Alias	00050
0	No. Of WD	0x0100	ST1/ST2	0x0000	USA/US5	0x0A14	ALM1/ALM2	0x9E9E	Scale Factor	0x04B0	NOS/REL	0x0103
1	WD1 Speed	0x0000	ST3/ST4	0x0000	OSA/OSS	0x0A14	ALM3/ALM4	0x9E9E	T1/T2	0x6C4F	PERALM/CNT	0x004B
2	Status	0x0000	ST5/ST6	0x0000	Calibration P...	0x0475	ALM5/ALM6	0x9E9E	T3/T4	0x42C2	WD4 Speed	0x0000
3	USA/US5	0x0000	ALM1/ALM2	0x0000	Scale Factor	0x04B0	NOS/REL	0x0208	T5/T6	0x11AA	Status	0x0000
4	OSA/OSS	0x0000	ALM3/ALM4	0x0000	T1/T2	0x4C50	PERALM/CNT	0x649C	ST1/ST2	0x0200	USA/US5	0x0000
5	Calibration PPM	0x0000	ALM5/ALM6	0x0000	T3/T4	0x3000	WD3 Speed	0x0000	ST3/ST4	0x0000	OSA/OSS	0x0000
6	Scale Factor	0x0000	NOS/REL	0x0000	T5/T6	0x4158	Status	0x4100	ST5/ST6	0x0000	Calibration PPM	0x0000
7	T1/T2	0x0000	PERALM/CNT	0x0000	ST1/ST2	0x0000	USA/US5	0x0A14	ALM1/ALM2	0x0045	Scale Factor	0x0000
8	T3/T4	0x0000	WD2 Speed	0x0484	ST3/ST4	0x0000	OSA/OSS	0x0A14	ALM3/ALM4	0x20D6	T1/T2	0x0000
9	T5/T6	0x0000	Status	0x2465	ST5/ST6	0x0000	Calibration PPM	0xFF19	ALM5/ALM6	0x8B4B	T3/T4	0x0000

Words 1 to 17 (pink) represent Watchdog 1. These are currently all 0 because watchdog 1 isn't present at this time. Words 18 to 34 (green) represent Watchdog 2. Word 18 which is 0484 HEX tells us that the Watchdog is currently running at 1156 pulses per minutes. Word 19 which is 2465 HEX tells us that the Watchdog is 'running (24) at 101% (65) of the calibrated speed. The remainder of the information in the example can be decoded using the information as previously described. Words 35 to 51 (blue) represent Watchdog 3. Word 35 which is 0000 HEX tells us that the Watchdog is currently NOT running. Word 36 which is 4100 HEX tells us that the Watchdog is in fact NOT calibrated (41), see the Watchdog manual for more detail about calibration.

### Diagnosics Display.

The F500 Elite is equipped with a simple RS232 serial interface. This interface can be used to monitor the communications with the Watchdog Elite. The information displayed contains diagnostic data about the Fieldbus module and Watchdog number 1. A VT100 or compatible display terminal should be used to display the information.

```

F500 Elite Communications Gateway - Watchdog NTC
Elite Software Version - 3.2.0

CUB Version= 1.00
API Version= 2.16
FBI Version= 1.05
ABI Version= 1.05
FieldBus Type = ModBus RTU
S2468E

DATA ARRAY FOR WATCHDOG NUMBER 1
  Speed 0423          ST1/ST2 0000
  Status 2464        ST3/ST4 0000
  USA/USS 0A14       ST5/ST6 0000
  OSA/OSS 0A14       ALM1/ALM2 9E9E
  Calib 0423         ALM3/ALM4 9E9E
  Scaling 04B0       ALM5/ALM6 9E9E
  T1/T2 605E         NOS/REL 022C
  T3/T4 3040        P-ALM/CNT 3CB1_
  T5/T6 A93A

Total Watchdogs Read = 1

```

Above is an *example* screen image from the diagnostics display. The information displayed will vary slightly dependent upon the fieldbus interface used.

- CBU Version = X.XX           – This is the control base unit software version.
- API Version = X.XX           – This is the application interface software version.
- FBI Version = X.XX           – This is the Fieldbus interface software version.
- ABI Version = X.XX           – This is the AnyBus interface software version.

Fieldbus type = Profibus DP – This describes the type of Fieldbus module which is installed in the F500 Elite. If the Fieldbus module is faulty some or all of this data will change to suggest which area may be at fault. For example, FBI version number might become 245.55. An unusually large number such as this is not usually associated with a normally functioning module and would suggest that the Fieldbus interface controller has failed. In the event of this or any other fault, contact your supplier.

The sequence S2468E indicated that the system has initialised correctly, a deviation from this indicates that one or more parts of the initialisation process has failed. If this is the case, recycle power and see if this clears the problem. If you still have problems with the initialisation of the unit contact your supplier and tell them what you see on the diagnostics display. The main area of the display shows the complete data from Watchdog address number 1 as described on pages 9 to 15 of this manual.

### **Diagnostics LED.**

Located on the main circuit board, just above the RS485 connections to the Watchdog you will find an LED indicator (usually RED). This indicator will flash every time the F500 attempts to communicate with the Watchdogs. The LED will normally flash at a consistent rate followed by a very short pause. The short pause indicates that the F500 is updating the information which it stores internally. A significant deviation from this sequence is an indication that there is a problem. If this happens, contact your supplier for further information.



**CHECK LIST**  
**For problems after initial start-up**

1. Is there excessive interference on the electrical power supply? Power conditioners and surge (spike) suppressor may have to be fitted.
2. Has the wiring for the Watchdog and Fieldbus been routed away from power cables?
3. Is the F500 Elite circuit properly grounded?
4. Is the Micro-processor control unit overheating, if so mount in temperature-controlled environment of maximum temperature 104°F (40°C).
5. Check that high powered 'Walkie Talkie' radios are not operated immediately near the control unit or Watchdogs as this will affect the performance.
6. Check that the communications/power cable is connected correctly and in accordance with DRG A,B,C and E.
7. Check that there is no exception status reported.
8. If only part of the diagnostics data is displayed on the terminal screen then turn the F500 Elite off then back on again without removing power to the display terminal.
9. If the Watchdogs are not responding or are intermittent, check that the termination resistors are correctly fitted.

**CONTACT INFORMATION**



**WWW.GO4B.COM**

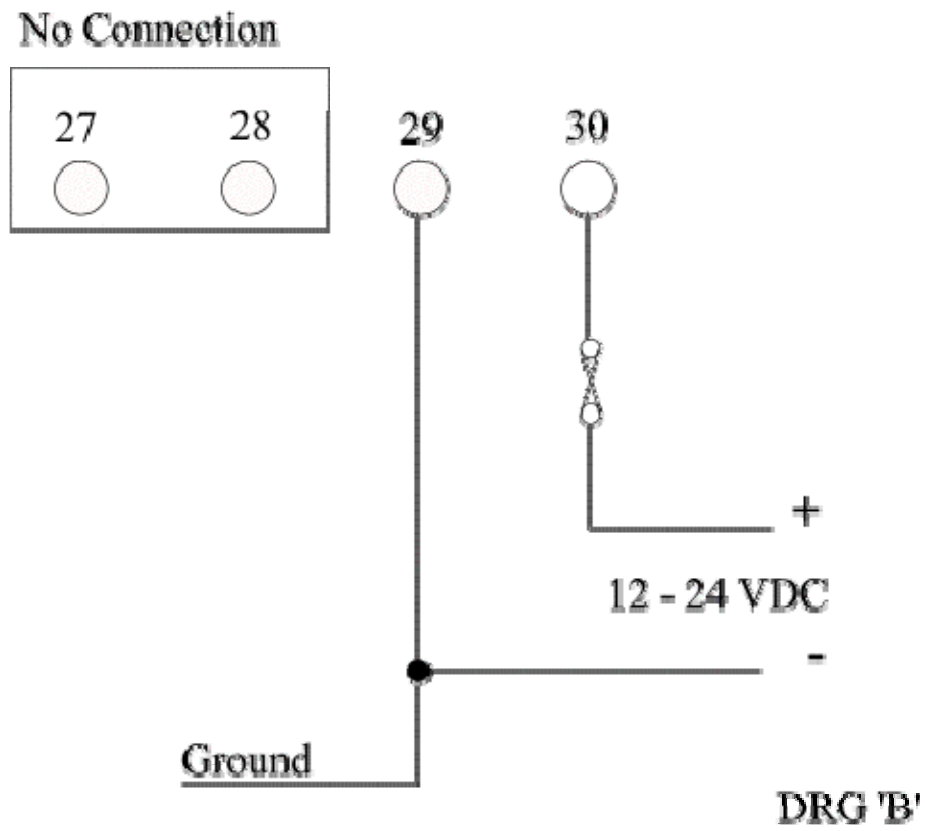
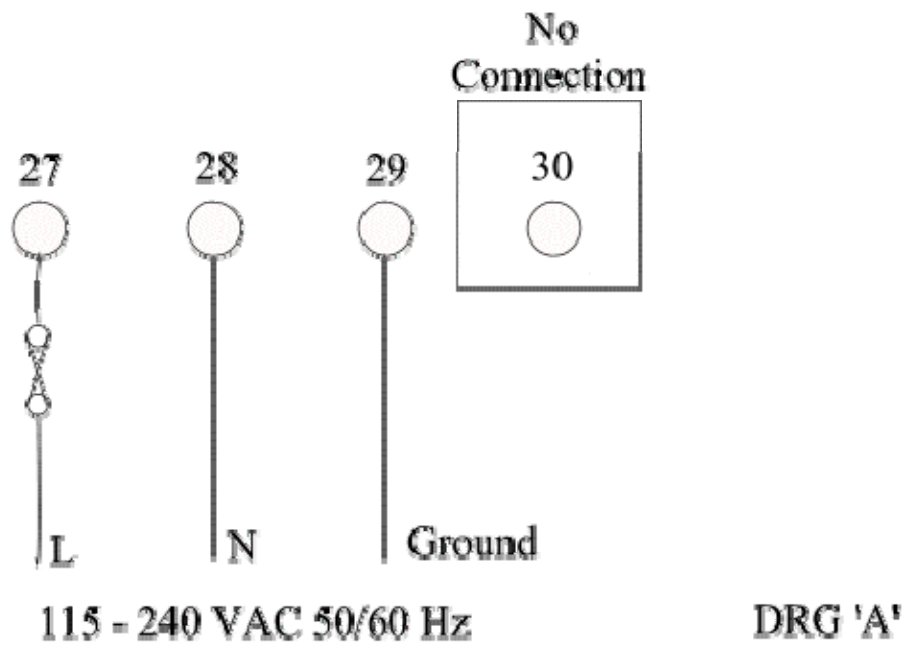

### F500 elite to Watchdog connections

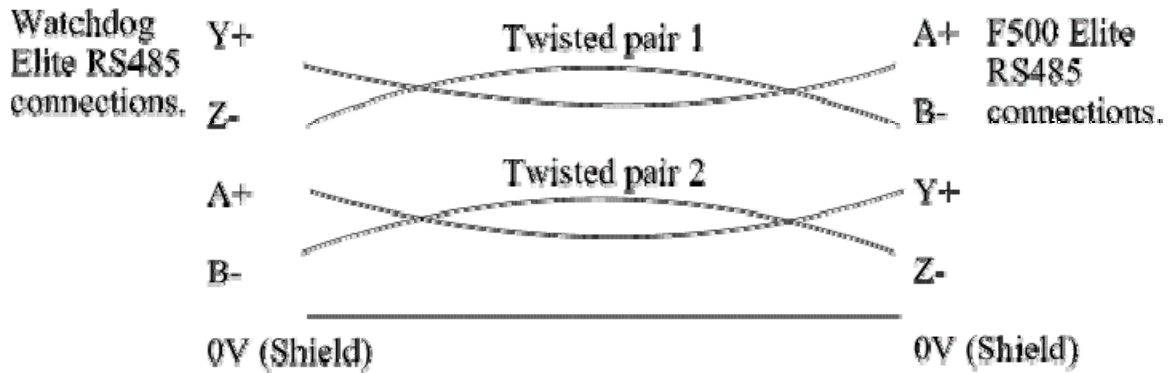
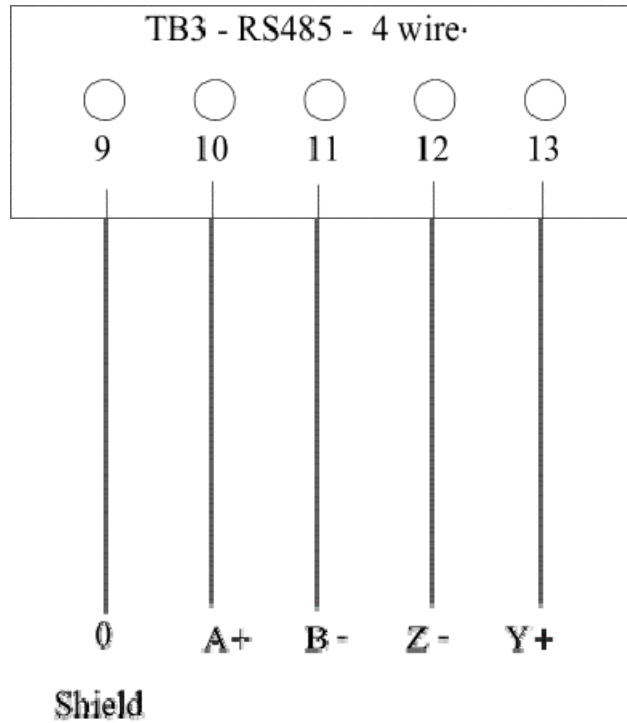

DRG 'C'

Connect 120 OHM ½ watt resistors between A+ and B- and between Y+ and Z- at both the F500 elite end and at the Watchdog which is furthest away from the F500 elite.

**F500 elite to VT100 terminal connections.**

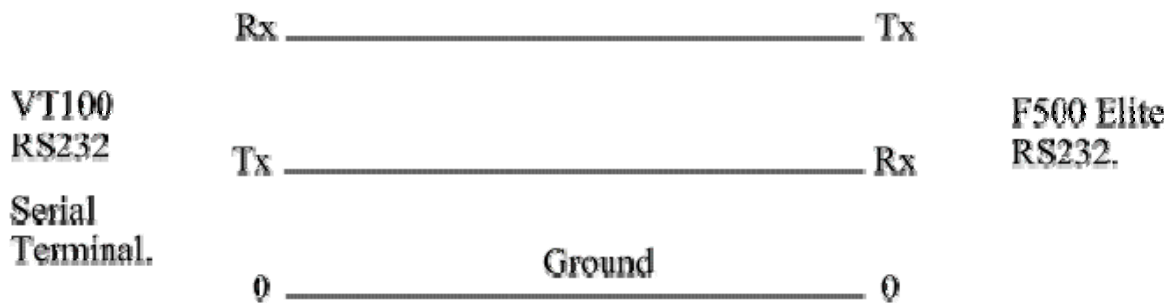
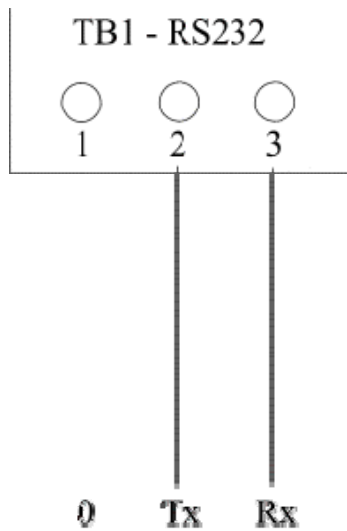

On more recent versions of the F500 TB1 may be a standard 9 pin Dee connector. This Dee connector is designed to work with a standard 9 pin to 9 pin serial lead for monitoring the F500

**DRG 'D'**

**General connection detail for the Watchdog to an F500 elite.**

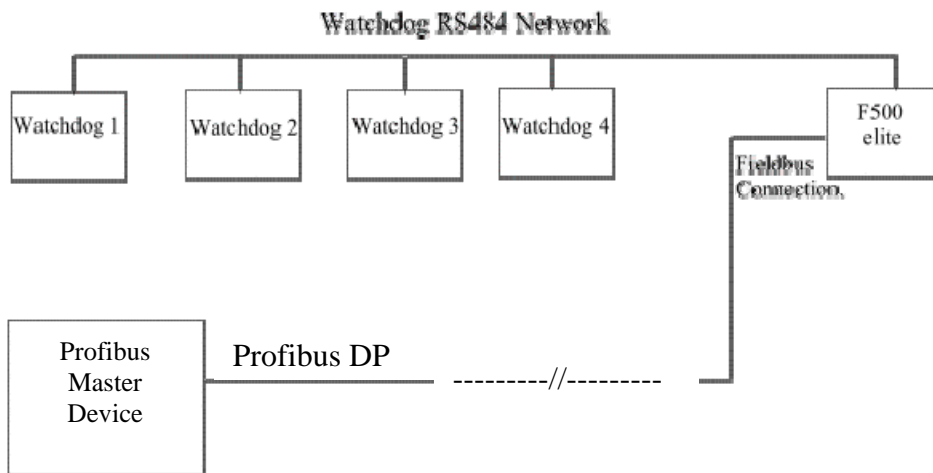
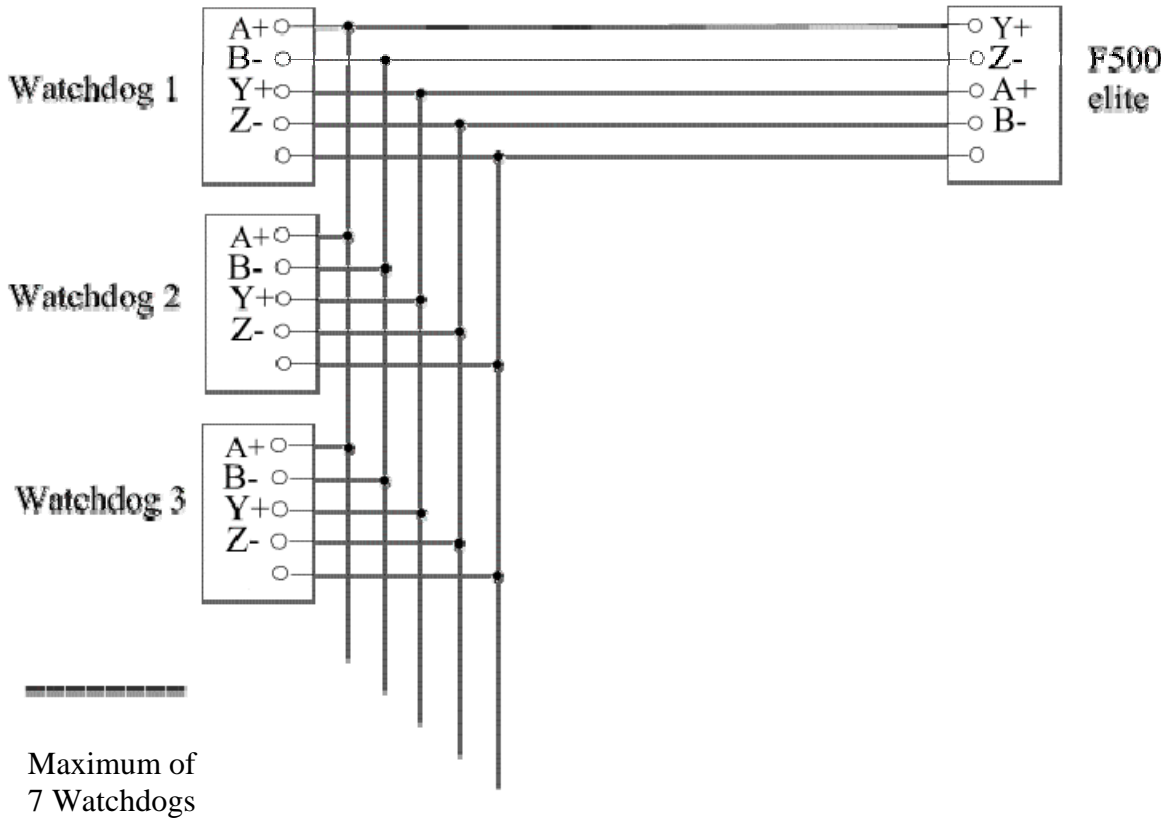

**DRG 'E'**

## APPENDIX 'A'

Master/Slave configuration.

The F500 when equipped with a Profibus interface is supplied with a GSD file on CD to aid with initial configuration if required. Should this file become corrupt or is lost then the following information can be used to recreate the file. The F500 does not require the use of the GSD file in order to operate correctly and this is only provided as a courtesy to the user. If you monitor 7 Watchdogs the interface will require 240 bytes of data storage in the Profibus interface. If you intend to use the GSD file then choose from the following options.

INPUT: 240 Bytes (120 words)

Or

INPUT: 64 Byte (32 word) + INPUT: 64 Byte (32 word) + INPUT: 64 Byte (32 word) +  
INPUT: 32 Byte (16 word) + INPUT: 16 Byte (8 word) = 240 bytes.

```
=====
; Profibus Device Database of HMS Industrial Networks.
; Model : ANYBUS-S PDP
; Description : ANYBUS-S Profibus DP slave
; Language : English
; Date : 12 March 2004
; Author : HMS Industrial Networks AB
;
=====
#Profibus_DP

; Device identification
Vendor_Name      = "HMS Industrial Networks AB"
Model_Name       = "ANYBUS-S PDP"
Revision         = "Version 1.5"
Ident_Number     = 0x1003
Protocol_Ident   = 0           ; DP protocol
Station_Type     = 0           ; Slave device
FMS_supp        = 0           ; FMS not supported
Hardware_Release = "Version 1.6"
Software_Release = "Version 1.2"

; Supported baudrates
9.6_supp        = 1
19.2_supp       = 1
45.45_supp      = 1
93.75_supp      = 1
187.5_supp      = 1
500_supp        = 1
1.5M_supp       = 1
```

3M\_supp = 1  
6M\_supp = 1  
12M\_supp = 1

; Maximum responder time for supported baud rates

MaxTsdr\_9.6 = 15  
MaxTsdr\_19.2 = 15  
MaxTsdr\_45.45 = 15  
MaxTsdr\_93.75 = 15  
MaxTsdr\_187.5 = 15  
MaxTsdr\_500 = 15  
MaxTsdr\_1.5M = 25  
MaxTsdr\_3M = 50  
MaxTsdr\_6M = 100  
MaxTsdr\_12M = 200

; Supported hardware features

Redundancy = 0 ; not supported  
Repeater\_Ctrl\_Sig = 2 ; TTL  
24V\_Pins = 0 ; not connected  
Implementation\_Type = "SPC3"

; Supported DP features

Freeze\_Mode\_supp = 1 ; supported  
Sync\_Mode\_supp = 1 ; supported  
Auto\_Baud\_supp = 1 ; supported  
Set\_Slave\_Add\_supp = 0 ; not supported

; Maximum polling frequency

Min\_Slave\_Intervall = 1 ; 100 us

; Maximum supported sizes

Modular\_Station = 1 ; modular  
Max\_Module = 24  
Max\_Input\_Len = 244  
Max\_Output\_Len = 244  
Max\_Data\_Len = 416  
Modul\_Offset = 1

Fail\_Safe = 0 ; Slave does not accept data frames with zero data length in state CLEAR.

Slave\_Family = 0  
Max\_Diag\_Data\_Len = 6

; Definition of modules

Module = "IN/OUT: 1 Byte" 0x30  
EndModule



```

;
Module = "IN/OUT: 2 Byte ( 1 word)" 0x70
EndModule
;
Module = "IN/OUT: 4 Byte ( 2 word)" 0x71
EndModule
;
Module = "IN/OUT: 8 Byte ( 4 word)" 0x73
EndModule
;
Module = "IN/OUT: 16 Byte ( 8 word)" 0x77
EndModule
;
Module = "IN/OUT: 32 Byte (16 word)" 0x7F
EndModule
;
Module = "IN/OUT: 64 Byte (32 word)" 0xC0,0x5F,0x5F
EndModule
;
Module = "IN/OUT: 128 Byte (64 word)" 0xC0,0x7F,0x7F
EndModule
;
Module = "INPUT: 1 Byte" 0x10
EndModule
;
Module = "INPUT: 2 Byte ( 1 word)" 0x50
EndModule
;
Module = "INPUT: 4 Byte ( 2 word)" 0x51
EndModule
;
Module = "INPUT: 8 Byte ( 4 word)" 0x53
EndModule
;
Module = "INPUT: 16 Byte ( 8 word)" 0x57
EndModule
;
Module = "INPUT: 32 Byte (16 word)" 0x5F
EndModule
;
Module = "INPUT: 64 Byte (32 word)" 0x40,0x5F
EndModule
;
Module = "INPUT: 128 Byte (64 word)" 0x40,0x7F
EndModule
;
Module = "OUTPUT: 1 Byte" 0x20
EndModule
;

```

```
Module = "OUTPUT: 2 Byte ( 1 word)" 0x60
EndModule
;
Module = "OUTPUT: 4 Byte ( 2 word)" 0x61
EndModule
;
Module = "OUTPUT: 8 Byte ( 4 word)" 0x63
EndModule
;
Module = "OUTPUT: 16 Byte ( 8 word)" 0x67
EndModule
;
Module = "OUTPUT: 32 Byte (16 word)" 0x6F
EndModule
;
Module = "OUTPUT: 64 Byte (32 word)" 0x80,0x5F
EndModule
;
Module = "OUTPUT: 128 Byte (64 word)" 0x80,0x7F
EndModule
```

## **WARRANTY INFORMATION**

### **1. EXCLUSIVE WRITTEN LIMITED WARRANTY**

ALL PRODUCTS SOLD ARE WARRANTED BY THE COMPANY (4B COMPONENTS LIMITED, (4B) BRAIME ELEVATOR COMPONENTS LIMITED, AND (4B) S.E.T.E.M. Sarl) HEREIN AFTER REFERRED TO AS 4B TO THE ORIGINAL PURCHASER AGAINST DEFECTS IN WORKMANSHIP OR MATERIALS UNDER NORMAL USE FOR ONE (1) YEAR AFTER DATE OF PURCHASE FROM 4B. ANY PRODUCT DETERMINED BY 4B AT ITS SOLE DISCRETION TO BE DEFECTIVE IN MATERIAL OR WORKMANSHIP AND RETURNED TO A 4B BRANCH OR AUTHORIZED SERVICE LOCATION, AS 4B DESIGNATES, SHIPPING COSTS PREPAID, WILL BE, AS THE EXCLUSIVE REMEDY, REPAIRED OR REPLACED AT 4B'S OPTION.

### **2. DISCLAIMER OF IMPLIED WARRANTY**

NO WARRANTY OR AFFIRMATION OF FACT, EXPRESSED OR IMPLIED, OTHER THAN AS SET FORTH IN THE EXCLUSIVE WRITTEN LIMITED WARRANTY STATEMENT ABOVE IS MADE OR AUTHORIZED BY 4B. 4B SPECIFICALLY DISCLAIMS ANY LIABILITY FOR PRODUCT DEFECT CLAIMS THAT ARE DUE TO PRODUCT MISUSE, ABUSE OR MISAPPLICATIONS, AS AUTHORIZED BY LAW, 4B SPECIFICALLY DISCLAIMS ALL WARRANTIES THAT THE PRODUCT IS FIT OR MERCHANTABLE FOR A PARTICULAR PURPOSE.

### **3. NO WARRANTY "BY SAMPLE OR EXAMPLE"**

ALTHOUGH 4B HAS USED REASONABLE EFFORTS TO ACCURATELY ILLUSTRATE AND DESCRIBE THE PRODUCTS IN ITS CATALOGS, LITERATURE, AND WEBSITES, SUCH ILLUSTRATIONS AND DESCRIPTIONS ARE FOR THE SOLE PURPOSE OF PRODUCT IDENTIFICATION AND DO NOT EXPRESS OR IMPLY A WARRANTY AFFIRMATION OF FACT, OF ANY KIND OR A WARRANTY OR AFFIRMATION OF FACT THAT THE PRODUCTS WILL CONFORM TO THEIR RESPECTIVE ILLUSTRATIONS OR DESCRIPTIONS. 4B EXPRESSLY DISCLAIMS ANY WARRANTY OR AFFIRMATION OF FACT, EXPRESSED OR IMPLIED, OTHER THAN AS SET FORTH IN THE EXCLUSIVE WRITTEN LIMITED WARRANTY STATEMENT ABOVE, INCLUDING, WITHOUT LIMITATION, THE IMPLIED WARRANTIES OF MERCHANTABILITY AND FITNESS FOR A PARTICULAR PURPOSE.

### **4. LIMITATION OF DAMAGES**

ANY LIABILITY FOR CONSEQUENTIAL, INCIDENTAL, SPECIAL, EXEMPLARY, OR PUNITIVE DAMAGES, OR FOR LOSS OF PROFIT WHETHER DIRECT OR INDIRECT, IS EXPRESSLY DISCLAIMED.