

## WARRANTY INFORMATION

### 1. EXCLUSIVE WRITTEN LIMITED WARRANTY

ALL PRODUCTS SOLD ARE WARRANTED BY THE COMPANY (4B COMPONENTS LIMITED, (4B) BRAIME ELEVATOR COMPONENTS LIMITED, AND (4B) S.E.T.E.M. Sarl) HEREIN AFTER REFERRED TO AS 4B TO THE ORIGINAL PURCHASER AGAINST DEFECTS IN WORKMANSHIP OR MATERIALS UNDER NORMAL USE FOR ONE (1) YEAR AFTER DATE OF PURCHASE FROM 4B. ANY PRODUCT DETERMINED BY 4B AT ITS SOLE DISCRETION TO BE DEFECTIVE IN MATERIAL OR WORKMANSHIP AND RETURNED TO A 4B BRANCH OR AUTHORIZED SERVICE LOCATION, AS 4B DESIGNATES, SHIPPING COSTS PREPAID, WILL BE, AS THE EXCLUSIVE REMEDY, REPAIRED OR REPLACED AT 4B'S OPTION.

### 2. DISCLAIMER OF IMPLIED WARRANTY

NO WARRANTY OR AFFIRMATION OF FACT, EXPRESSED OR IMPLIED, OTHER THAN AS SET FORTH IN THE EXCLUSIVE WRITTEN LIMITED WARRANTY STATEMENT ABOVE IS MADE OR AUTHORIZED BY 4B. 4B SPECIFICALLY DISCLAIMS ANY LIABILITY FOR PRODUCT DEFECT CLAIMS THAT ARE DUE TO PRODUCT MISUSE, ABUSE OR MISAPPLICATIONS, AS AUTHORIZED BY LAW, 4B SPECIFICALLY DISCLAIMS ALL WARRANTIES THAT THE PRODUCT IS FIT OR MERCHANTABLE FOR A PARTICULAR PURPOSE.

### 3. NO WARRANTY "BY SAMPLE OR EXAMPLE"

ALTHOUGH 4B HAS USED REASONABLE EFFORTS TO ACCURATELY ILLUSTRATE AND DESCRIBE THE PRODUCTS IN ITS CATALOGS, LITERATURE, AND WEBSITES, SUCH ILLUSTRATIONS AND DESCRIPTIONS ARE FOR THE SOLE PURPOSE OF PRODUCT IDENTIFICATION AND DO NOT EXPRESS OR IMPLY A WARRANTY AFFIRMATION OF FACT, OF ANY KIND OR A WARRANTY OR AFFIRMATION OF FACT THAT THE PRODUCTS WILL CONFORM TO THEIR RESPECTIVE ILLUSTRATIONS OR DESCRIPTIONS. 4B EXPRESSLY DISCLAIMS ANY WARRANTY OR AFFIRMATION OF FACT, EXPRESSED OR IMPLIED, OTHER THAN AS SET FORTH IN THE EXCLUSIVE WRITTEN LIMITED WARRANTY STATEMENT ABOVE, INCLUDING, WITHOUT LIMITATION, THE IMPLIED WARRANTIES OF MERCHANTABILITY AND FITNESS FOR A PARTICULAR PURPOSE.

### 4. LIMITATION OF DAMAGES

ANY LIABILITY FOR CONSEQUENTIAL, INCIDENTAL, SPECIAL, EXEMPLARY, OR PUNITIVE DAMAGES, OR FOR LOSS OF PROFIT WHETHER DIRECT OR INDIRECT, IS EXPRESSLY DISCLAIMED.



#### 4B COMPONENTS

729 Sabrina Drive  
East Peoria, Illinois 61611  
USA  
Tel: 309 -698 -5611  
Fax: 309-698-5615  
e-mail: 4b-usa@go4b.com  
Web: www.go4b.com

#### 4B BRAIME ELEVATOR COMPONENTS

Hunslett Road  
Leeds, LS10 1JZ  
England  
Tel: +44 (0) 113 246 1800  
Fax: +44 (0) 113 243 5021  
e-mail: 4b-uk@go4b.com  
Web: www.go4b.com

#### 4B SETEM

9 Route de Corbie  
80800 Lamotte Warfusée  
France  
Tel: +33 (0) 3 22 42 32 26  
Fax: +33 (0) 3 22 42 37 33  
e-mail: 4b-france@go4b.com  
Web: www.go4b.com



## SPEEDSWITCH M800 UNDERSPEED MONITOR



**WARNING:**  
*O.S.H.A. requires that all exposed rotating shafts are provided with a full guard. Therefore, this device and its target must be equipped with a guard.*

## INSTALLATION INSTRUCTIONS

## TECHNICAL INFORMATION

**UNDERSPEED MONITOR - PART Nos. 220V ac M8001V2FC  
110V ac M8001V1FC  
24V dc M8001V4FC**



**OUTPUT LED FAULT CODE:**

Orange: Programming not accepted, unit has defaulted back to previous programme settings and requires re-programming.

Red: Follow procedure "Recalibration for a different setting". If the output LED remains red, contact your supplier.

**BASIC FAULT FINDING**

- 1) Input light does not illuminate.  
Check that you have a supply of the correct value across the brown and blue wires. Slide a screwdriver blade across the face of the sensor, the input light should flicker. If not, contact your supplier. If it does, move the front face nearer the target and check target size is as specified under "Installation".
- 2) Input light stays on permanently.  
Either increase the gap between the target and the shaft, or between the target and the sensor face.

**ELECTRICAL SPECIFICATION**

- Supply** \_\_\_\_\_ 110V ac or 220V ac 50/60 Hz or 24V dc (specify when ordering).
- Fusing** \_\_\_\_\_ Unit should be wired to a supply rated at 5A maximum.
- Speed Range** \_\_\_\_\_ 10-3600 PPM. (Pulses Per Minute).
- Operating Range** — 9mm max. (ferrous) 6mm max. (non-ferrous)
- Operating Temp.** — -25°C to +70°C
- Target** \_\_\_\_\_ Ideally ferrous min. 20mm dia. Accessory M500 TG Target Disc Available.
- Start up Delay** \_\_\_\_\_ User Selectable 0-30 Seconds
- Calibration** \_\_\_\_\_ Unit is automatically calibrated by the application of a magnet. (Applied to CAL point on label when shaft is running at speed).
- Repeat Accuracy** \_\_\_\_\_ Better than 2%
- Enclosure** \_\_\_\_\_ Moulded PC/ABS.
- Protection** \_\_\_\_\_ IP67 dust & water tight.
- Trip Point** \_\_\_\_\_ Using Single Set Point either 10% or 20% underspeed. Using Dual Set Points both 10% and 20% underspeed.
- Output Relay** \_\_\_\_\_ First Relay Normally Open. Contact Closes at 10% speed. Second Relay Normally Closed. Opens at -20% speed. Rated 2.5A 240V AC.
- LED Display** \_\_\_\_\_ RED LED indicates input pulses. GREEN LED shows output at nominal speed and acts as calibration aid. It may flicker during normal operation.
- Weight** \_\_\_\_\_ 185 grams.
- Tacho Output** \_\_\_\_\_ Opto-isolated output provided, rated at 30V dc 100mA max, fully protected. To feed tachos and other electronic equipment.

**GUARANTEE**

The equipment is covered by a 12 months guarantee from the date of shipment. Any faults arising due to faulty materials or workmanship, within the guarantee period, will be corrected free of charge providing the equipment is returned to us carriage paid.

**Dear 4B Customer:**

Congratulations on your purchase. 4B appreciates your business and is pleased you have chosen our products to meet your needs.

Please read in its entirety and understand the literature accompanying the product before you place the product into service. Please read the safety precautions carefully before operating the product. With each product you purchase from 4B, there are some basic but important safety considerations you must follow to be sure your purchase is permitted to perform its design function and operate properly and safely, giving you many years of reliable service. Please read and understand the Customer Safety Responsibilities listed below. Failure to follow this safety directive and the Operation Manuals and other material furnished or referenced, may result in serious injury or death.

**SAFETY NOTICE TO OUR CUSTOMERS**

- A. In order to maximize efficiency and safety, selecting the right equipment for each operation is vital. The proper installation of the equipment, and regular maintenance and inspection is equally important in continuing the proper operation and safety of the product. The proper installation and maintenance of all our products is the responsibility of the user unless you have asked 4B to perform these tasks.
- B. All installation and wiring must be in accordance with Local and National Electrical Codes and other standards applicable to your industry. (Please see the article "Hazard Monitoring Equipment Selection, Installation and Maintenance" at [www.go4b.com](http://www.go4b.com).) The installation of the wiring should be undertaken by an experienced and qualified professional electrician. Failure to correctly wire any product and/or machinery can result in the product or machine failing to operate as intended, and can defeat its design function.
- C. Periodic inspection by a qualified person will help assure your 4B product is performing properly. 4B recommends a documented inspection at least annually and more frequently under high use conditions.
- D. Please see the last page of this manual for all warranty information regarding this product.

**CUSTOMER SAFETY RESPONSIBILITIES****1. READ ALL LITERATURE PROVIDED WITH YOUR PRODUCT**

Please read all user, instruction and safety manuals to ensure that you understand your product operation and are able to safely and effectively use this product.

**2. YOU BEST UNDERSTAND YOUR NEEDS**

Every customer and operation is unique, and only you best know the specific needs and capabilities of your operation. Please call the 24-hour hotline at 309-698-5611 for assistance with any questions about the performance of products purchased from 4B. 4B is happy to discuss product performance with you at any time.

**3. SELECT A QUALIFIED AND COMPETENT INSTALLER**

Correct installation of the product is important for safety and performance. If you have not asked 4B to perform the installation of the unit on your behalf, it is critical for the safety of your operation and those who may perform work on your operation that you select a qualified and competent electrical installer to undertake the installation. The product must be installed properly to perform its designed functions. The installer should be qualified, trained, and competent to perform the installation in accordance with Local and National Electrical Codes, all relevant OSHA Regulations, as well as any of your own standards and preventive maintenance requirements, and other product installation information supplied with the product. You should be prepared to provide the installer with all necessary installation information to assist in the installation.

**4. ESTABLISH AND FOLLOW A REGULAR MAINTENANCE AND INSPECTION SCHEDULE FOR YOUR 4B PRODUCTS**

You should develop a proper maintenance and inspection program to confirm that your system is in good working order at all times. You will be in the best position to determine the appropriate frequency for inspection. Many different factors known to the user will assist you in deciding the frequency of inspection. These factors may include but are not limited to weather conditions; construction work at the facility; hours of operation; animal or insect infestation; and the real-world experience of knowing how your employees perform their jobs. The personnel or person you select to install, operate, maintain, inspect or perform any work whatsoever, should be trained and qualified to perform these important functions. Complete and accurate records of the maintenance and inspection process should be created and retained by you at all times.

**5. RETAIN AND REFER TO THE OPERATION MANUAL FOR 4B'S SUGGESTED MAINTENANCE AND INSPECTION RECOMMENDATIONS**

As all operations are different, please understand that your specific operation may require additional adjustments in the maintenance and inspection process essential to permit the monitoring device to perform its intended function. Retain the Operation Manual and other important maintenance and service documents provided by 4B and have them readily available for people servicing your 4B equipment. Should you have any questions, please call the 4B location who supplied the product or the 24-hour hotline number in the USA -309-698-5611.

**6. SERVICE REQUEST AND ONLINE PRODUCT REGISTRATION**

If you have questions or comments about the operation of your unit or require the unit to be serviced please contact the 4B location who supplied the product or send your request via fax (309-698-5615), email ([4b-usa@go4b.com](mailto:4b-usa@go4b.com)), or call us via our 24-hour hotline number in the USA - 309-698-5611. Please have available product part numbers, serial numbers, and approximate date of installation. In order to assist you, after the product has been placed into service, complete the Online Product Registration section which is accessed via our website [www.go4b.com](http://www.go4b.com)

## GENERAL

The M800 motion monitor detects slip, low or zero speed on belt and bucket elevator legs, conveyors or rotating machinery.

The unit requires no contact with the shaft, is fully solid state, and has a virtually unlimited operating life. The M800 may be used either as a dual trip unit giving an alarm at 10% below set speed and a shutdown signal at 20% below set speed, or a single trip giving a shutdown signal at 20%. With the addition of an auxiliary relay, it can also give a shut down signal at 10% (see fig. 4).

An automatic calibration facility allows the unit to be programmed to give a start up delay of up to 30 seconds, whilst simultaneously calibrating for nominal speed.

An auxiliary pulse output is provided to feed suitable speed indicators.

## INSTALLATION

The inductive sensing device, located in the front of the M800 enclosure is designed to detect a metal target on a shaft. The target can be a bolt head or similar.

Ideally, the target should be a ferrous metal but non-ferrous metal will detect at a shorter range. Maximum range for a ferrous material is 11/32" (9mm) and for non-ferrous metal is 7/32" (6mm), assuming a 3/4" (19mm) diameter target. Smaller targets may be used but operating distance will be reduced.

The M800 should be mounted adjacent to the target, ensuring that the distance to the target does not exceed the stated maximum. Typical mounting methods are shown in fig 1.

When mounted against a solid steel shaft, the target or bolt head should protrude from the shaft about 3/8" (10mm). Otherwise the sensor will not be able to separate the target from the shaft and the red input light would stay on permanently (instead of flickering) and it would not be possible to calibrate the unit.

## TACHOOUTPUT

An opto-isolated output is provided, rated at 30V 100mA max. The output is on when the target is detected and off otherwise. This output pulse can be used to feed remote tachos or other electronic products.

### Mounting Procedure For Speedswitch M800 Motion Monitor

Fasten the Speedswitch to a suitable mounting bracket, with the nose of the switch within the sensing range of the target., as shown below, and then wire up and calibrate as described in Set-up procedure.

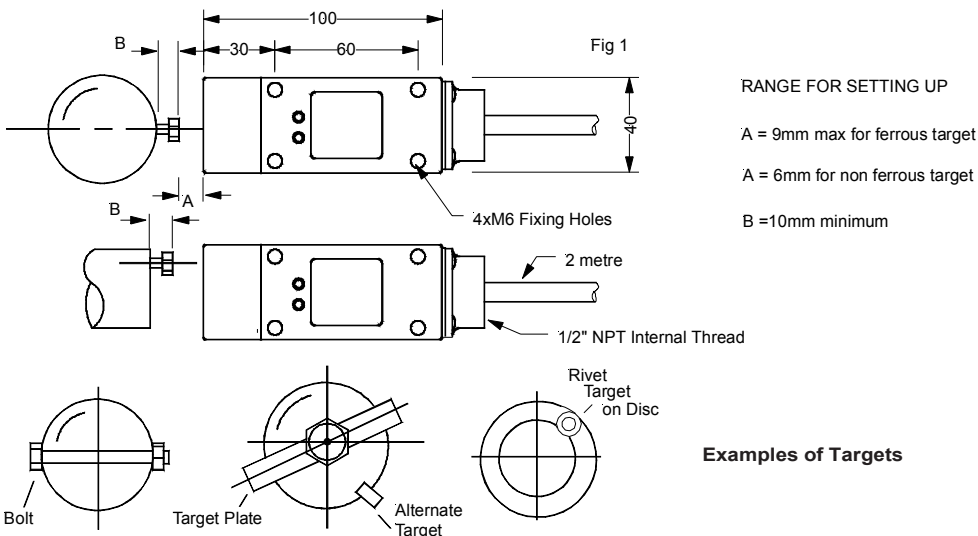

## WIRING

The unit connections and typical wiring diagrams are given in figs. 2,3 4 and 5. Note that contacts are voltage free and there is no connection between terminal 1 and the relay, until links are installed as required. See figs. 2,3 and 4. Note that the startup is initiated by applying power

## COMMISSIONING & AUTO-CALIBRATION

The M800 is factory calibrated at a set speed of 10 ppm and a start up delay of 5 seconds. For applications requiring a different speed or delay, see initial Setting up Operation. For future re-calibration see Re-Calibration for a Different Setting.

### INITIAL CALIBRATION

If the start up delay required is less than 5 seconds (if longer, see re-calibration below).

- 1) Ensure that all connections are correct.
- 2) Apply power to the M800 and start machinery.
- 3) Allow the machine to reach nominal speed and then hold either end of the magnet (supplied) on the CAL point on the label for the start up delay required then remove the magnet. The delay can be set by counting flashes on the output LED while the magnet is on the CAL point. Each flash represents 1 second.
- 4) The output LED will flash to 'echo' back the set time and will automatically calibrate to 10% and 20% below speed.

### RE-CALIBRATION FOR A DIFFERENT SETTING

If the unit is to be calibrated to a higher speed and shorter time delay, follow the initial procedure detailed above. If the speed is lower or the required delay longer, the M800 may cut out before the machine has reached speed, in this case follow the procedure below:-

- 5) Hold one end of the magnet on the CAL point.
- 6) Switch on the M800 and machinery.
- 7) Allow the machinery to reach speed and remove the magnet.
- 8) Wait until the output light stops flashing and then calibrate as detailed under Initial Calibration 3&4.

## Connections

