

# WATCH DOG



**elite**

BUCKET ELEVATOR  
& Belt Conveyor  
MONITORING SYSTEM

## INSTALLATION/OPERATION MANUAL

### WDC3V46C

Revision 1.5 (CSA) – January 2007

#### APPROVALS

The Watchdog Control Unit is approved for use in:

CSA CLII DIV1 GP's E, F & G (Canada)  
CSA CLII DIV2 GP's F & G (USA)

Hazardous locations – (see page 41)

**WARNING:** The Watchdog uses an LCD type display, therefore exposure to direct sunlight must be avoided.



[www.go4b.com](http://www.go4b.com)

US: 309-698-5611

UK: +44 (0) 113 246 1800

F: +33 (0) 3 22 42 32 26

D: +49 (0) 700 224 24091



Pulley  
Alignment

Bearing  
Temperature

Plug  
Condition

Belt Speed and  
Alignment  
(Head and Boot)

**WATCH DOG**  
**elite**

**1 SPECIFICATIONS 5**

1.1 Control Unit ..... 5  
 1.1.1 Electrical Ratings ..... 5  
 1.1.2 Dimensions ..... 5  
 1.1.3 LCD - Liquid Crystal Display ..... 5  
 1.1.4 Touch Buttons ..... 5  
 1.1.5 LED Status Lamps ..... 6  
 1.1.6 Communications Port ..... 6  
 1.1.7 System Parameters ..... 6  
 1.2 Elevator Motion Probe ..... 7  
 1.3 Bearing Temperature Sensor ..... 7  
 1.4 Bearing Temperature Sensor - Hazardous Locations ..... 8  
 1.5 NTC Bearing Temperature Sensor ..... 8  
 1.6 Plug Switch ..... 8  
 1.7 Head Pulley Alignment Sensors ..... 8

**2 WATCHDOG INSTALLATION INSTRUCTIONS 9**

2.1 Introduction ..... 9  
 2.2 Installation & Wiring - Non-Hazardous Areas ..... 17  
 2.3 Hazardous Locations ..... 17  
 2.4 Operation & Adjustment in Hazardous Locations ..... 17

**3 ELECTRICAL WIRING 19**

3.1.1 Block Diagram - Non - Hazardous Locations ..... 19  
 3.1.2 Block Diagram - Class II Hazardous Locations ..... 19  
 3.2 Wiring Requirements ..... 20  
 3.3 Wiring Details ..... 20  
 3.3.1 Control Wiring - Diagram 'I' ..... 20  
 3.3.2 Sensor Wiring - Diagram 'J' ..... 22  
 3.3.3 Multiple Control Units to a Single Alarm Device - Diagram 'K' ..... 24  
 3.4 Printed Circuit Board Details ..... 25

**4 OPERATING INSTRUCTIONS 26**

4.1 First time use & Initial Calibration ..... 26  
 4.2 Re-Calibration ..... 26  
 4.3 Wrong Calibration ..... 26  
 4.4 Setting the Watchdog Parameters ..... 27  
 4.4.1 'Engineer' Setup ..... 27  
 4.4.2 'Factory' Setup ..... 27

4.5	Engineer Adjustable Operating Parameters	27
4.5.1	Scale Factor	27
4.5.1.1	Example 1: Percentage	28
4.5.1.2	Example 2: Tons/Hour	28
4.5.1.3	Example 3: Feet/Minute	28
4.5.1.4	Example 4: Metres/Minute	28
4.5.1.5	Example 5: Cubic Metres/Hour	28
4.5.1.6	Example 6: Tones/Hour	29
4.5.1.7	Example 7: Bushels/Hour	29
4.5.1.8	Example 8: Cubic Feet/Hour	29
4.5.2	Underspeed Alarm	29
4.5.3	Underspeed Stop	30
4.5.4	Overspeed Alarm	30
4.5.5	Overspeed Stop	30
4.5.6	Startup Delay	30
4.5.7	Number of MAS	30
4.5.8	Misalignment Sensing	30
4.5.9	Number of HBS zones	30
4.5.10	Plug Switch	30
4.5.11	Head Pulley Alignment Sensor	30
4.5.12	Comms ID	30
4.6	Factory Adjustable Operating Parameters	31
4.6.1	Engineer Code	31
4.6.2	Acceleration Monitoring	31
4.6.3	Stop on Hot Bearing	31
4.6.4	Type of Thermistor	31
4.6.5	Speed Range	31
4.6.6	Smoothing Factor	31
4.6.7	Misalignment Delay	31
4.6.8	Misalignment Ratio	31
4.6.9	Persistent Alarm Delay	31
4.6.10	Relay Delay	31
4.6.11	Overspeed Alarm Delay	31
4.6.12	Overspeed Stop Delay	31
4.7	The 'Test' Function	32
4.7.1	Test Settings	32
4.7.2	Full Test	32
4.8	Normal Operation	32
4.8.1	Motion Probe Connections & Probe LEDS	32
4.8.2	Starting & Accelerating	33
4.8.3	Underspeed Detection	33
4.8.4	Overspeed Detection	33
4.8.5	Misalignment Detection	34
4.8.6	Bearing Over-Temperature Detection	34
4.8.7	Persistent Alarm Conditions	34
4.8.8	Stop (Shutdown) Conditions	35
4.8.9	Power-Fail Conditions	35

**5 CHECK LIST (For Problems after Initial Start-up) 36**

**6 FAULT FINDING CHART 37**

**7 WARNING MESSAGES 38**

**8 LIABILITY & WARRANTY 39**

**9 MOUNTING BLOCK TEMPLATE 40**

**10 HAZARD LOCATIONS 41**

---

# INTRODUCTION

## “Watchdog” Motion, Alignment and Temperature System

The ‘Watchdog’ system is a user-programmable, microprocessor controlled bucket elevator monitor. The control unit accepts signals of speed and alignment from elevator buckets or elevator bolts. Additional signals of bearing temperature, plugged chute and head pulley alignment are able to effect an alarm and provide shutdown control of the elevator, and of feeding system, when hazardous conditions are detected. Microprocessors and electronics are housed in a self-contained wall-mounting enclosure, and the motion/alignment sensors, temperature sensors, plugged chute sensors and pulley alignment sensors are separate items for mounting on the elevator.

### Abbreviations used in this manual:

PPM Pulses per Minute  
LCD Liquid Crystal Display  
BPH Bushels per Hour  
LED Light Emitting Diode  
HBS Hot Bearing Sensor  
MAS Motion Alignment sensor  
PLC Programmable Logic Controller  
HPAS Head Pulley Alignment Sensor

### Motion Sensing - General Features

The Watchdog accepts signals from between one and four probes mounted on the bucket elevator. A probe will provide one pulse for every ferrous object detected, (e.g. a bucket or bolt) which passes within its sensing range. The Watchdog compares the speed given by these input signals with a preset value, (the ‘calibrated speed’) and is able to affect an alarm or shutdown if there is a deviation from the Calibrated speed of more than the programmed percentage. These percentages are fully user-selectable. A digital display of speed is provided on the front panel of the Watchdog which can be scaled as required by a programmable Scale Factor. The Watchdog also accepts a signal from the motor starter which will initiate a programmable start-up timer. During this start-up time the speed is monitored and if insufficient acceleration is detected, (e.g. due to a blockage) a stop signal will be generated to shut down the elevator leg. A full test feature is also provided on the Watchdog Control Unit. This test feature displays the programmed percentages and actively tests the internal and external alarm and shutdown circuits.

### Alignment Sensing - General Features

Two probes mounted on the elevator will detect belt speed from the pulses generated by the passing buckets or bolts. If the elevator belt becomes misaligned, one of the probes will fail to detect the buckets or bolts. The control unit will recognise the absence of pulses as a misalignment condition, display the location of the misalignment and will affect an alarm signal, which can eventually result in shutdown of the elevator and other equipment.

Alignment can be detected by either one pair of probes mounted at the top OR bottom of the elevator, or by two pairs of probes, one set at the bottom AND one set at the top.

## Temperature Sensing - General Features

The Watchdog has inputs for up to six zones of temperature sensors. Each of the elevator shaft bearings can be fitted with a temperature sensor to detect overheating. Sensors can also be fitted to detect the temperature of oil in a gearbox, etc. The temperature sensors have a preset switching temperature, which if exceeded, causes an alarm followed by an elevator shutdown if the condition persists. Additionally, special NTC Thermistor Sensors are available which provide a linear output for the control unit to display the temperature of the bearings.

## Serial Communications - General Features

The Watchdog can be connected to a 'Host' computer or PLC via a serial link (RS422/485) which enables remote two-way communication with the Watchdog.

## Installation

When installing the 'Watchdog' system we strongly advise that you employ the services of a certified and licensed electrician, who is familiar with installation of electronic controls. If assistance is required in obtaining an installation electrician please contact us and we will recommend an electrical contractor.

## Control Unit Dimensions



# 1. SPECIFICATIONS

## 1.1 The Control Unit WDC3V46C

A polycarbonate enclosure houses the electronics, displays, and the terminal connectors. The watchdog contains two printed circuit boards. A lower board accommodates the power supply circuitry, output relays and opto-isolators for the input signals. The upper board is mounted in the hinged lid and houses the microprocessors and the circuitry associated with the display and touch buttons. The two boards are connected by a short ribbon cable. In normal use there are no adjustments required inside the case, all settings being performed via the front panel touch buttons.



**CAUTION**  
**DO NOT REMOVE COVER WHILE CIRCUITS ARE LIVE.**  
**REPLACE COVER AND TIGHTEN SCREWS**  
**BEFORE APPLYING POWER.**



### 1.1.1 Electrical Ratings

TABLE 1

Electrical Supply	- 24 VDC or 100 to 260 VAC WDC3V46C
Power Consumption	- 12 Watts maximum
Starter Interlock Input	- 24VDC OR 110V +/- 10% 50/60Hz 2.5mA or 220V +/- 10% 50/60Hz 5mA
Alarm Relay Contacts	- 1 Pole changeover 240V AC , 10 A max
Stop Relay Contacts	- 1 Pole changeover 240V AC , 10 A max
Additional relay contacts for under speed, misalignment, and bearing temperature are available with the optional PLC Interface Board.	
Probe Inputs	- 24V DC Approx.
Probe Supply	- 24V DC Approx. Current 1A available
Protection	- CSA CLII DIV1 GP's E,F & G (Canada) - CSA CLII DIV2 GP's F & G (USA)

### 1.1.2 Dimensions

TABLE 2

HEIGHT	12.1"	308mm
WIDTH	9.5"	241mm
DEPTH	5.4"	137mm
HOLE CENTRES	10.75" x 6"	273 mm x 153 mm
CABLE ENTRY	2 HOLES @ 3/4" CONDUIT	20mm
WEIGHT	6lbs	2.8 kg

### 1.1.3 LCD - Liquid crystal display

This is viewed through the front panel. It is used for displaying status messages, menu options and the values of preset parameters.

### 1.1.4 Touch buttons

The menu system is controlled by using the touch buttons on the front of the unit.

TABLE 3

Red	- Touch Pad 'A' - or UP
Yellow	- Touch Pad 'B' - or DOWN
Green	- Touch Pad 'C' - or ENTER

The Touch button pads use the very latest in touch switch technology. They are designed to work with the human finger. If dirt or moisture come in contact or build up on the touch sensor pads, then the electronics will self re-calibrate and remove the effects of the dirt/moisture resulting in normal operation once more.

## 1.1.5 LED Status Lamps - viewed through front panel

TABLE 4

Green	Top left probe	Green	Top right probe
Green	Lower left probe	Green	Lower right probe
Yellow	Alarm lamp		
Red	Stop lamp		

## 1.1.6 Communications Port

The Watchdog has a RS422/RS485 communications port for a serial connection to a host computer. The connections are shown below:

TABLE 5

Receive from host (Rx)	+A	-B
Transmit to host (Tx)	+Y	-Z

For further information on serial comms with the Watchdog, refer to data sheet WDD 1.1.6 (available from 4B).

## 1.1.7 System Parameters

The Watchdog is normally supplied with its programmable parameters preset to default values. Table 6 shows the available 'engineer' range of adjustment of each parameter. The range is selected through the main menu 'Setup' option. Each unit is supplied with an

'Engineer's' access code to enable on site programming. Special Customized on-site 'Factory' programming is available by calling 4B. (Phone numbers on front of manual).

TABLE 6

Parameter	Units	Default Settings	Engineer range	
			Min	Max
Scale Factor	-	12.00	0.01	99.99
Underspeed alarm	%	10	5	20
Underspeed stop	%	20	5	20
Over calibrated alarm speed	%	10	5	20
Over calibrated stop speed	%	20	5	20
Start up delay	Seconds	10	1	30
Number of MAS	-	2	1	4
Number of HBS zones	-	6	0	6
Comms ID	-	1	1	32
Speed Range	PPM	2000	-	-
Smoothing factor	-	10	-	-
Misalignment delay	Seconds	6	-	-
Acceleration Monitoring	-	Yes	Factory	
Stop on Hot Bearing (No Delay)	-	No	Adjustment	
Misalignment ratio	%	66	Only	-
Persistent Alarm delay	Seconds	180	-	-
Relay delay	Seconds	1.5	-	-
Overspeed alarm delay	Seconds	10	-	-
Overspeed stop delay	Seconds	20	-	-
Type of Thermistor	-	PTC	PTC	NTC
Plug Switch	-	No	Yes	No
Pulley Alignment	-	No	Yes	No



## 1.2 The Elevator Motion Probe - WDA3V34C

The probe is designed to detect moving ferrous targets which pass within its sensing range. It will not detect non-ferrous materials such as plastics, rubber, stainless steel, aluminium, etc., and it will not detect a stationary or slow moving object. It is designed to detect steel elevator buckets, from the side or front of the elevator leg steel bolts used to attach non-metallic buckets to the elevator belt, by sensing from the back of the belt. With two probes correctly mounted, belt misalignment can also be detected.

Contained within the probe is a powerful magnet and an electronic detector circuit. The enclosure is manufactured from stainless steel and all of the components are rigidly encapsulated in epoxy resin. A six conductor cable is attached to the outer end of the probe and a threaded conduit bushing is used to permit the use of flexible conduit systems for cable protection. An LED is moulded into the outer end of the probe and this is arranged to flash each time a target is detected; this LED enables easy adjustment of the probe, and an adjusting screw is provided to enable the sensitivity of the probe to be altered. The maximum and minimum limits of the adjusting screw can be felt by positive stops. A clamp block is provided to attach the probe to the elevator panels and to allow easy sliding adjustment of sensing distance. Performance details and dimensions are shown in Table 7.

TABLE 7 ELEVATOR MOTION PROBE

ELECTRICAL SUPPLY	-	12/24 V DC Approx. From Control Unit
SUPPLY CURRENT	-	65ma (max at 24 V)
OUTPUT SIGNAL	-	12/24 V DC Approx. Pulsed (dependent upon supply)
MIN. TARGET SIZE	-	1" Dia. (25mm Dia.)
MAX. TARGET DISTANCE-	-	3" [ 75mm Approx. (for 1" or 25mm Dia. Target) ]
MIN. TARGET SPEED	-	20 Ft/Min. (0-1 meters/second)
MAX. TARGET SPEED	-	2000 Ft/Min. (10 meters/second)
MAX. PULSE RATE	-	2000 Per Min. (High Speed Probes Available)
DIAMETER	-	2" (50 mm)
LENGTH	-	5 ¾" (150mm)
WEIGHT	-	24oz (0.7Kg)
CABLE	-	9ft Long (3m Long)
CONDUIT ENTRY	-	1/2" NPT thread, (1/2" NPT to 20 mm adapter available)
PROTECTION	-	CSA CL2 DIV1 GP's E, F & G

## 1.3 Bearing Temperature Sensor - WDB14V3C

The temperature Sensor is designed to screw into the bearing housing in a grease nipple hole or other tapped hole and will detect excessive temperature of the bearing housing. The sensor contains a positive temperature coefficient (PTC) Thermistor which has a fixed switching temperature. Below this switching temperature, the Thermistor has a low electrical resistance and above this temperature it has a very high resistance. The system fails to safe, as if the wire is broken at one of the sensors, an alarm signal is generated. A two conductors + screen PVC covered cable is permanently attached to the sensor body. A grease nipple is provided in the body of the sensor to allow greasing of the bearing in the normal manner.

TABLE 8 WDB14V3CA BEARING SENSORS

SWITCHING TEMPERATURE	-	176°F + 9°F (Others are available)
RESISTANCE AT (60°C) 140°F	-	-250 Ohms Max
RESISTANCE AT (100°C) 212°F	-	-2000 Ohms Min
SENSING VOLTAGE	-	12V DC Approx.
MAX. CURRENT	-	20ma
MOUNTING THREAD	-	1/8" NPTF
CABLE	-	2 Conductors + screen 10ft (3 Mtr.) Long
WEIGHT	-	7 oz. (0.2 Kg)
PROTECTION	-	CSA /cus Class 2 Div 1 Group E, F, and G

---

## 1.4 Bearing Temperature Sensor - WDB24V3C

The temperature sensor is designed to screw into the bearing housing in a grease nipple hole or other tapped hole and will detect excessive temperature of the bearing housing. The sensor contains a positive temperature coefficient (PTC) Thermistor which has a fixed switching temperature. Below this switching temperature, the Thermistor has a low electrical resistance and above this temperature it has a very high resistance. The system fails to safe, as if the wire is broken at one of the sensors, an alarm signal is generated. A two conductors + screen cable is permanently attached to the sensor body. The steel body is provided with a 1/2" NPT conduit entry for use with liquid tight flexible metal conduit. A grease nipple is provided in the body of the sensor to allow greasing of the bearing in the normal manner.

TABLE 9

SWITCHING TEMPERATURE	- 176°F + 9°F(Other Temperatures are available)
RESISTANCE AT (60°C) 140°F	- 250 Ohms Max
RESISTANCE AT (100°C) 212°F	- 2000 Ohms Min
SENSING VOLTAGE	- 12V DC Approx.
MAX. CURRENT	- 20ma
MOUNTING THREAD	- 1/8 " NPTF
CABLE	- 3 Conductor 6ft (2Mtr.) Long
CONDUIT ENTRY	- 1/2" NPTF
WEIGHT	- 7 oz. (0.2Kg)
PROTECTION	- CSA cus - Class II Division 1, Groups E, F and G

## 1.5 NTC — Bearing Temperature Sensor

Contact your supplier for the available options.

## 1.6 Plug Switch

The plug switch is designed to mount on the discharge or inlet spout of the elevator, and to warn of a plug condition. The switch uses a solid state capacitance circuit to detect when material surrounds the end of the polycarbonate housing. A signal is sent back to the control unit, which displays "plug condition" on the LCD display. Contact your supplier for the available options.

## 1.7 Head Pulley Alignment Sensors

Sensors for monitoring the head pulley alignment, contact your supplier for the available options.

---

## 2 WATCHDOG INSTALLATION INSTRUCTIONS

### 2.1 Introduction

To install the "Watchdog" first check that all of the parts of the system that were ordered have been received -  
Control Unit  
Motion / Alignment Sensors Bearing  
Temperature Sensors

#### CONTROL UNIT

The control unit should be installed in a suitable location away from excessive heat, moisture and vibration and mounted at an eye level position so that the display and warning lights can be easily seen. There should be sufficient space to open the hinged lid for wiring.



#### ATTENTION

The Control Unit can be susceptible to static voltage. Connection of a clean ground to terminal 16 is essential for optimum performance. Prior to this connection, static handling precautions should be taken.

**ALL WIRING MUST BE IN ACCORDANCE WITH LOCAL AND NATIONAL ELECTRICAL CODES AND SHOULD BE UNDERTAKEN BY AN EXPERIENCED AND PROFESSIONAL, QUALIFIED ELECTRICIAN.**

### **IMPORTANT**

**You must observe all warnings indicated in this manual. Failure to do so will void manufacturer's warranty and may cause serious injury or death.**

**The certification of this product does not permit the drilling/punching of additional cable entry holes into the body of the enclosure. To do so will void both certification and warranty and may cause serious injury or death.**

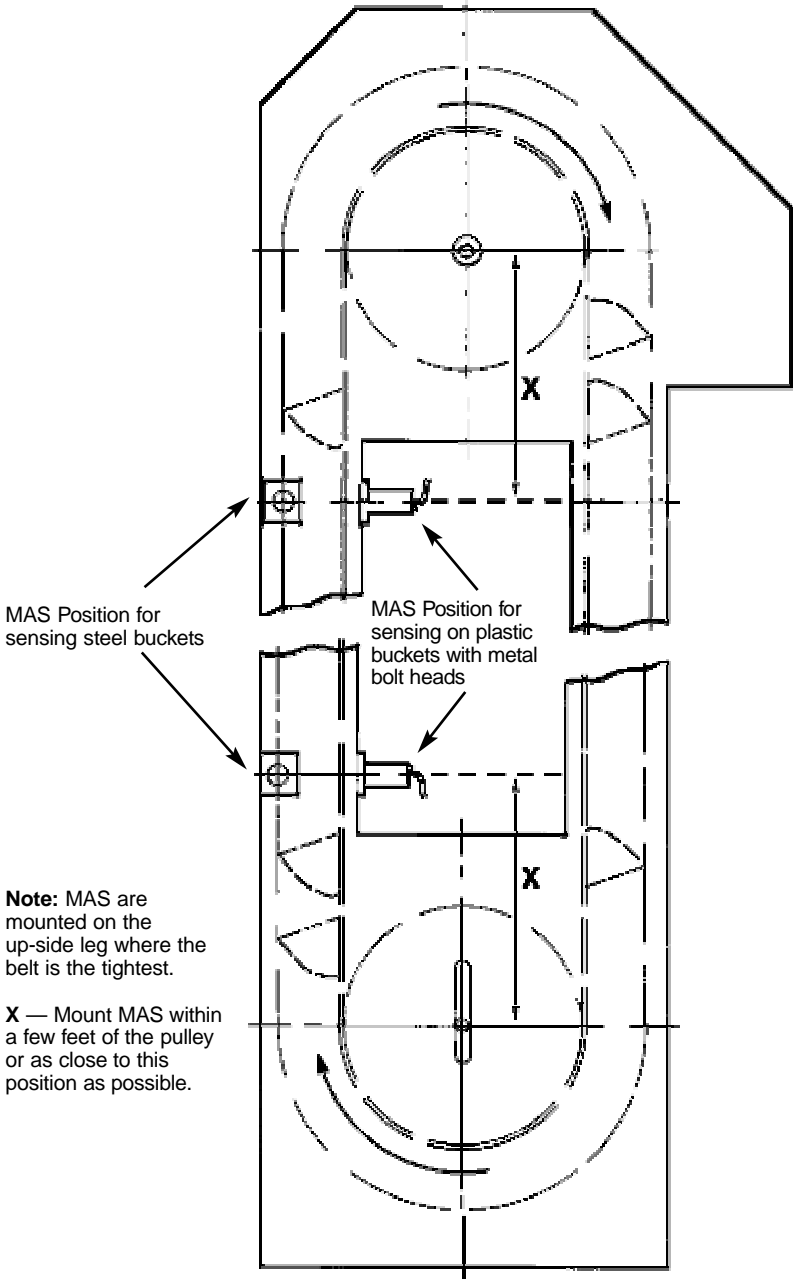

**TYPICAL PROBE SENSING POSITIONS  
ON UP LEG OF ELEVATOR**

**DRG. A**

**Steel Buckets**

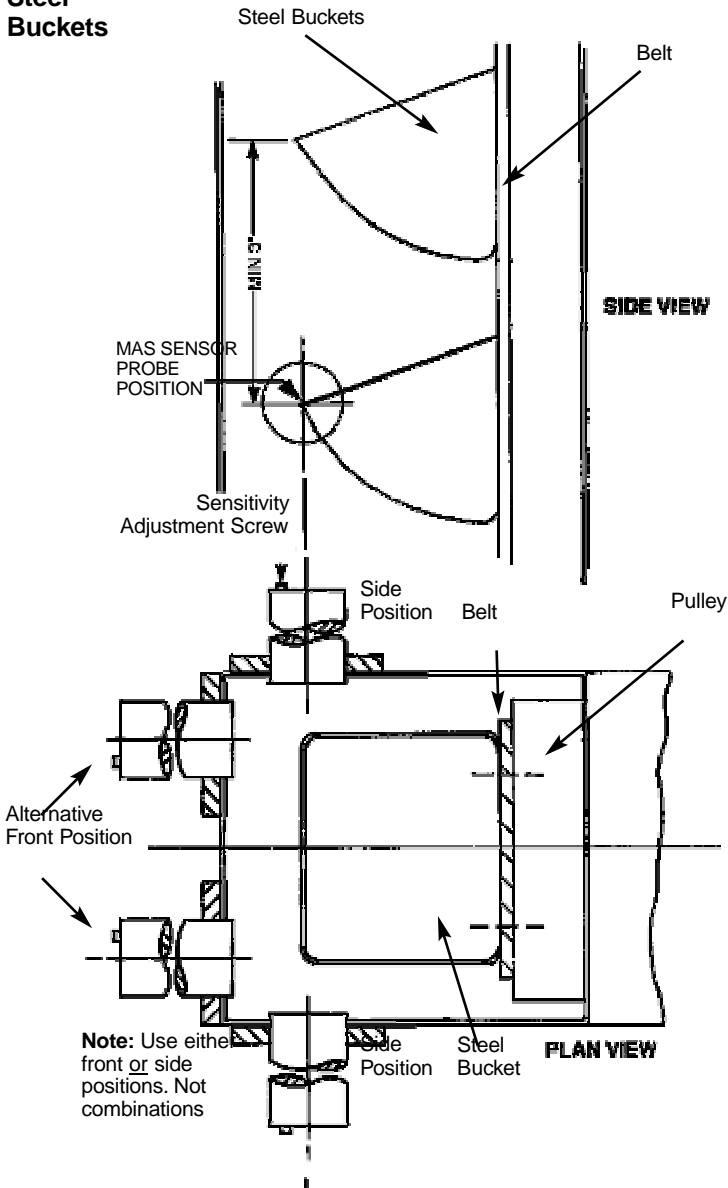

**MAS  
SENSOR POSITIONS  
FOR BELT ALIGNMENT AND  
BELT SLIP SENSING WITH ELEVATOR STEEL BUCKETS**

**DRG. B**

# Plastic Buckets

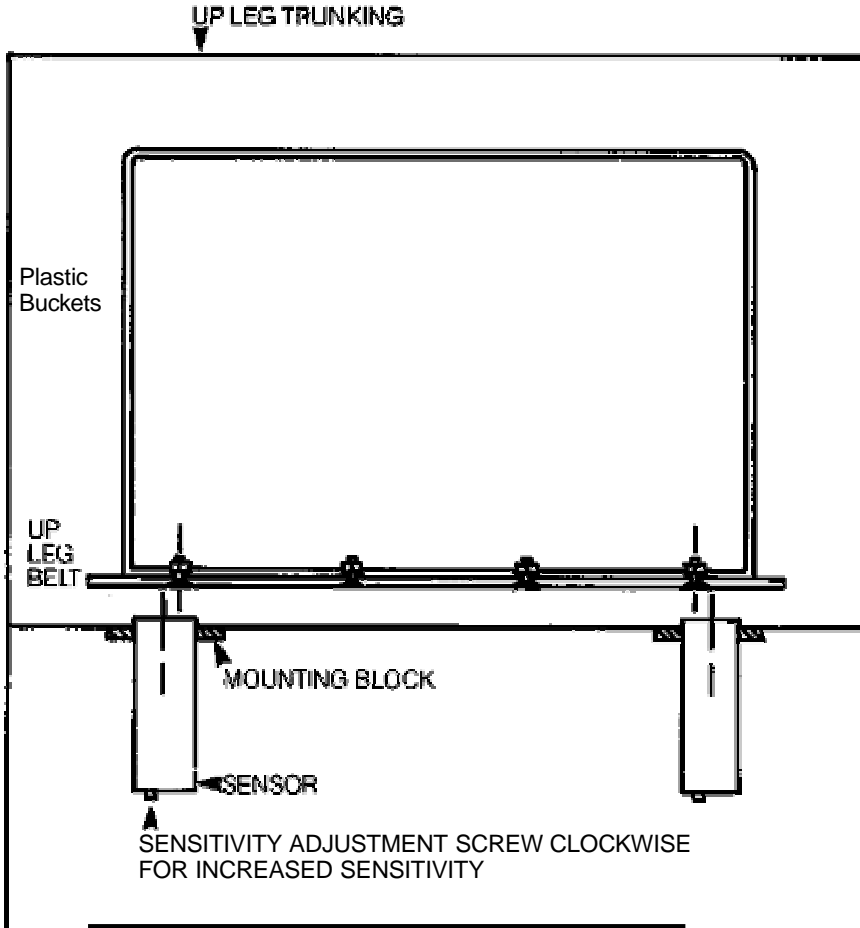

The green LED shows the state of the pulsed output and flashes once for each bucket (bolt) detected. The LED should be off when no buckets (bolts) are detected, if not, reduce the sensitivity.

PLAN VIEW

## MAS SENSOR POSITIONS FOR BELT ALIGNMENT AND BELT SLIP SENSING ON PLASTIC BUCKETS WITH STEEL BOLTS

DRG. D

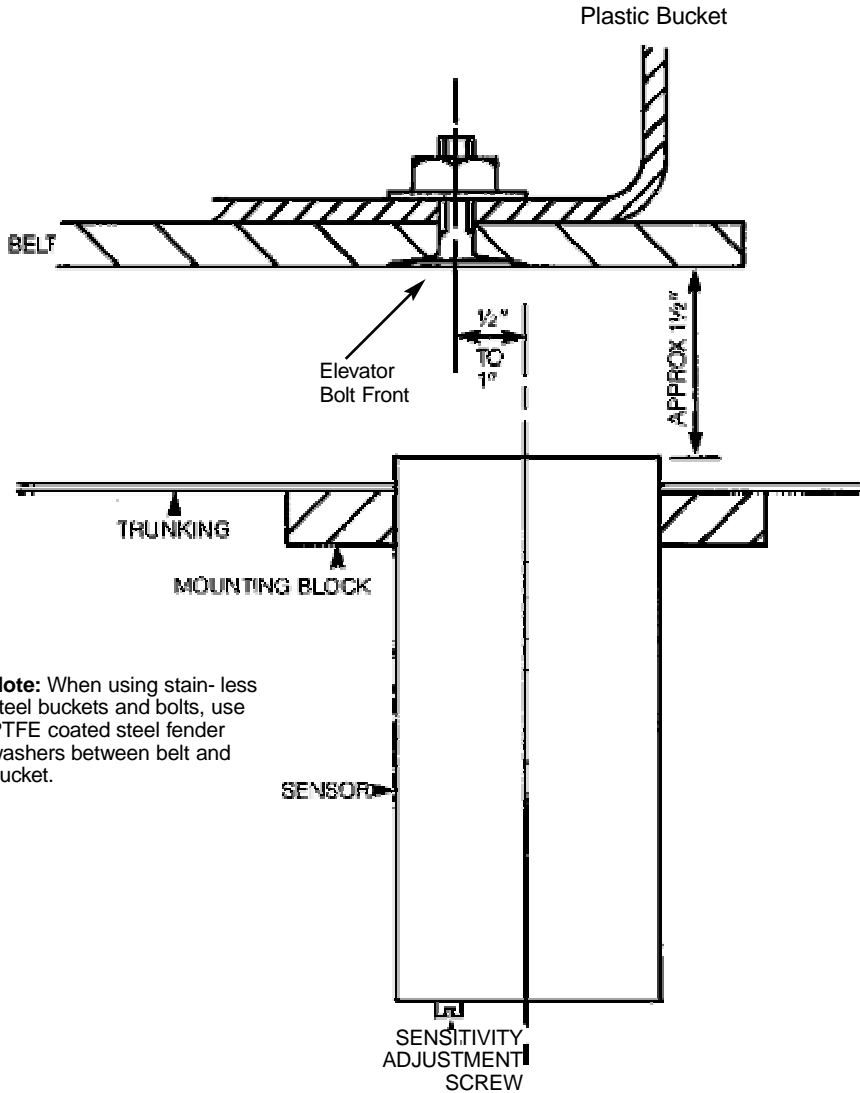

**Note:** When using stainless steel buckets and bolts, use PTFE coated steel fender washers between belt and bucket.

PLAN VIEW

**WATCHDOG ELITE MAS POSITION  
FOR BELT ALIGNMENT  
SENSING ON BOLTS**

DRG. E

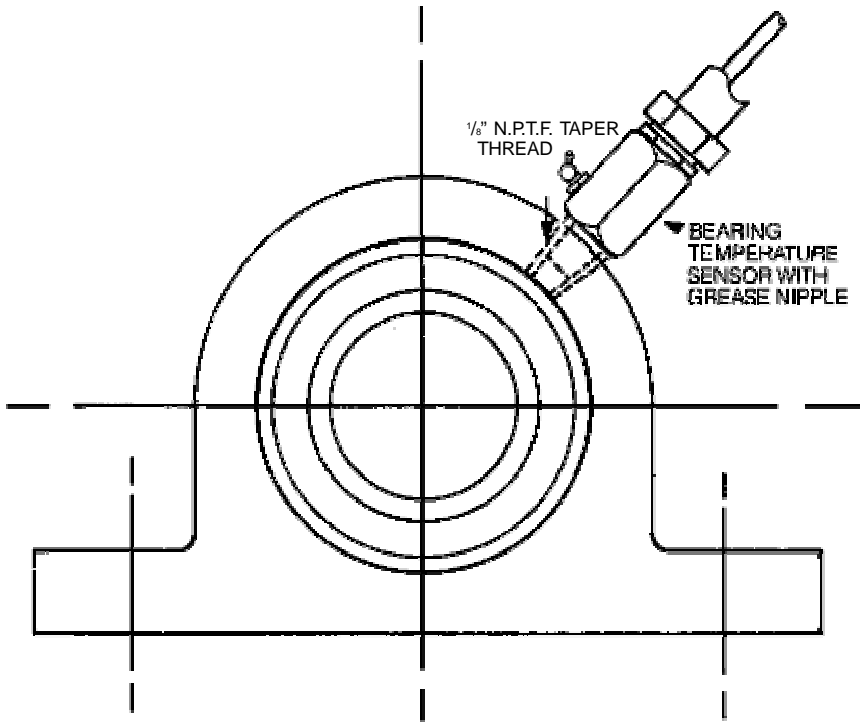

## INSTALLATION OF BEARING TEMPERATURE SENSOR

DRG. F

NOTE



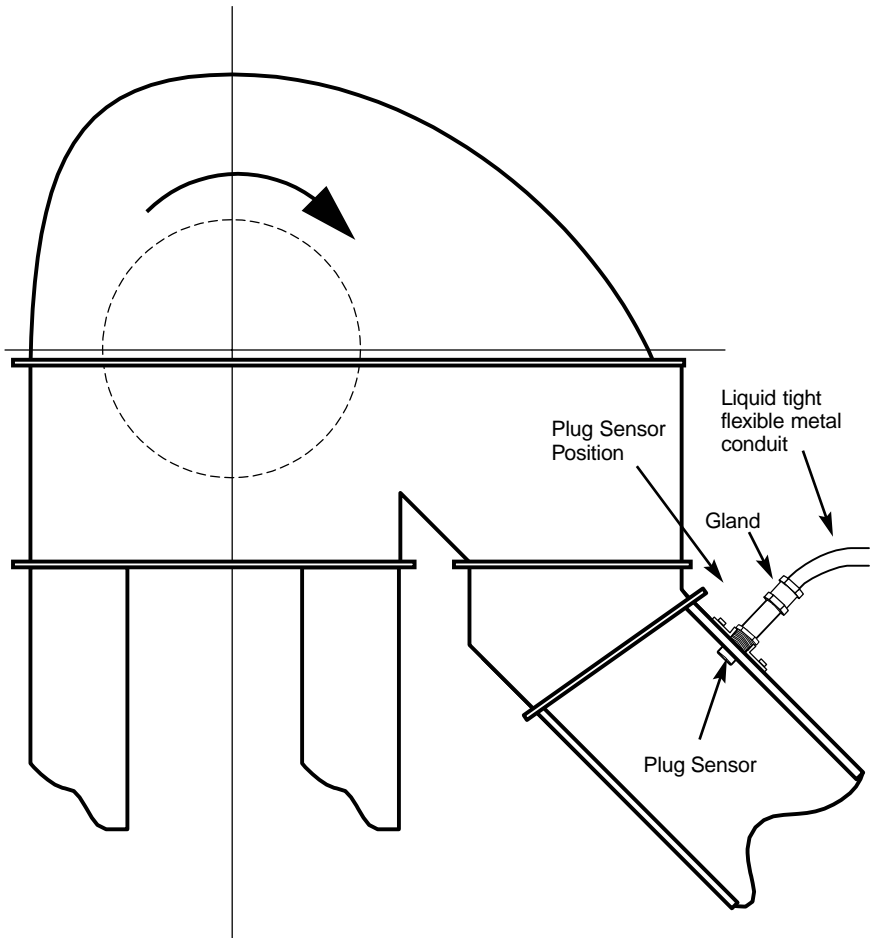

**ELEVATOR PLUG SENSOR**  
SHOWN AT ELEVATOR HEAD.

DRG. G

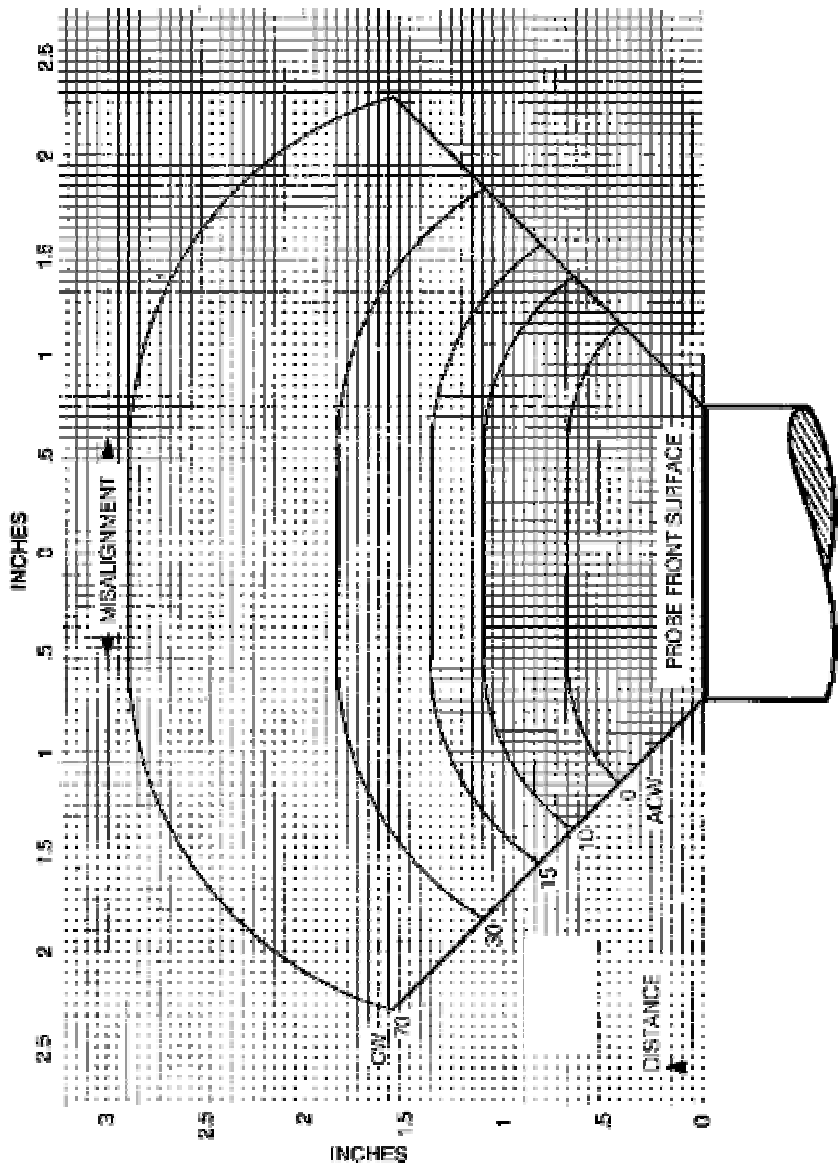

---

## 2.2. Installation and Wiring - Non Hazardous Areas

**MAS probes** should be mounted in a position which is accessible for adjustment, and protected from possible damage. As the probes may have to be moved slightly during adjustment, the wiring to them must be in flexible conduit. Mount a conduit junction box within 10ft (3 meters) of the motion probe - generally one junction box can be used for a pair of motion probes. Connect the probe(s) to the junction box using flexible conduit. Connect the junction box back to the control unit using either conduit or cable suitable for permanent wiring.

The **temperature probes** should be installed to the bearing housing in place of the bearing grease nipple. The sensor is grease-through to allow greasing of the bearing. Mount a junction box within 10 ft (3 metres) of each probe (or each pair of probes).

Connect the flexible cable from the temperature probe into the junction box using a strain relief cable gland. Connect the junction box back to the control unit using either rigid conduit or cable suitable for permanent wiring.

**Note:** The wiring between the motion probes, temperature sensors, and control unit has to be suitable for low level electrical signals (nominally 24 volts DC) and care should be taken to avoid electrical interference from other equipment. These wires should be run in either rigid steel conduit, without any other cables, or should be run with shielded wires, the shield being grounded at one end only. **We strongly recommend the use of shielded wires when wiring the motion probes to the microprocessor control unit.**

The **control unit** is designed for wall mounting either in a control room or near to the motor start equipment. However, as with all computerised systems care should be taken not to expose the microprocessor unit to excessive ambient temperatures, or potential electrical interferences. It should be located where it is readily accessible for set-up and adjustment. The two conduit entries are suitable for 3/4" conduit, but as the enclosure of the control unit is non-metallic, no ground continuity is provided through the enclosure. Each conduit must be terminated in a suitable bushing which provides ground continuity such as Allen-Bradley - 1490-N19.

## 2.3. Hazardous Locations

The Watchdog has been designed for use in certain hazardous locations, where the hazard is known to be Ignitable Dust.

If the Watchdog equipment is to be used on an elevator which will be handling grain or similar products, it is likely that the atmosphere inside the elevator leg during normal use will contain ignitable dust in suspension in the air. This area within the elevator leg is normally defined as a Category 1 hazardous location.

If the elevator is contained within a building where ignitable dust is not normally in suspension in the air but can accumulate normally on the surfaces of equipment, this can also be hazardous. This location is normally defined as a Category 2 hazardous location.

Watchdog Control Unit type WDC3V46C is approved for use in:  
CSA CLII DIV2 GP's E, F & G (Canada)  
CSA CLII DIV2 GP's F & G (USA)

The Watchdog MAS Probe is approved for use in:  
CSA CLII DIV1 GP's E, F & G

The Temperature Sensor Probe is approved for use in  
CSA CLII DIV1 GP's E, F & G

---

## Installation and Wiring - Hazardous Locations

**Consult the national electrical standards prior to installation.**

**MAS probes** should be mounted in a position which is accessible for adjustment, and protected from possible damage. As the probes may have to be moved slightly during adjustment, the wiring to them must be in liquid-tight flexible metal conduit with approved fittings. Mount a dust tight conduit junction box within 10ft (3 meters) of the motion probe generally one junction box can be used for a pair of motion probes. Connect the probe(s) to the junction box using liquid tight flexible metal conduit with approved fittings. Connect the junction box back to the control unit using either conduit or cable suitable for permanent wiring and ensure that dust tight seals are used.

**Temperature probes installation** into the bearing housings should be done generally as described in paragraph 2.1. Mount a dust tight conduit junction box within 10ft (3 meters) of each probe (or each pair of probes). Connect the flexible cable from the temperature probe into the conduit junction box using a strain relief cable gland (cord clamp) which meets dust tight requirements. Connect the junction box back to the control unit using either conduit or cable suitable for permanent wiring and ensure that dust tight seals are used. The installation of the Category 1 temperature sensor probes is identical to that on the standard temperature probe except that dust/liquid tight flexible metal conduit with approved fittings is required between the temperature probe(s) and the conduit junction box.

The wiring between the motion probes, temperature probes and control unit has to be suitable for low level electrical signals (nominally 24 volts DC), and care must be taken to avoid electrical interference from other equipment. If rigid steel conduit is used, do not run any other cables in the same conduit. Avoid running the signal wiring near any motor cables or other heavy power cables.

**We strongly recommend the use of shielded wires when wiring the motion probes to the microprocessor control unit.**

## 2.4 Operation and Adjustment in Hazardous Locations

The motion probes can be adjusted for physical position on the elevator leg, but great care must be taken to ensure that there is no possibility of the elevator belt or buckets striking and damaging the motion probes.

Due to electrical shock and dust hazards, the control unit must not be opened whilst power is applied. Before unfastening the main lid of the unit, switch off the power and wait for a few minutes. The lid can then be hinged to give access to the terminal connections.

With the control unit lid closed, set-up adjustments are made via the three front panel touch button pads.

The supply to the external sensors is protected by two fuses. F1 protects the motion probes and F2 protects the bearing temperature sensors. These fuses are rated as T5R(T) 1A and must only be replaced with identical devices.

### 3 ELECTRICAL WIRING

#### 3.1.1 Block Diagram

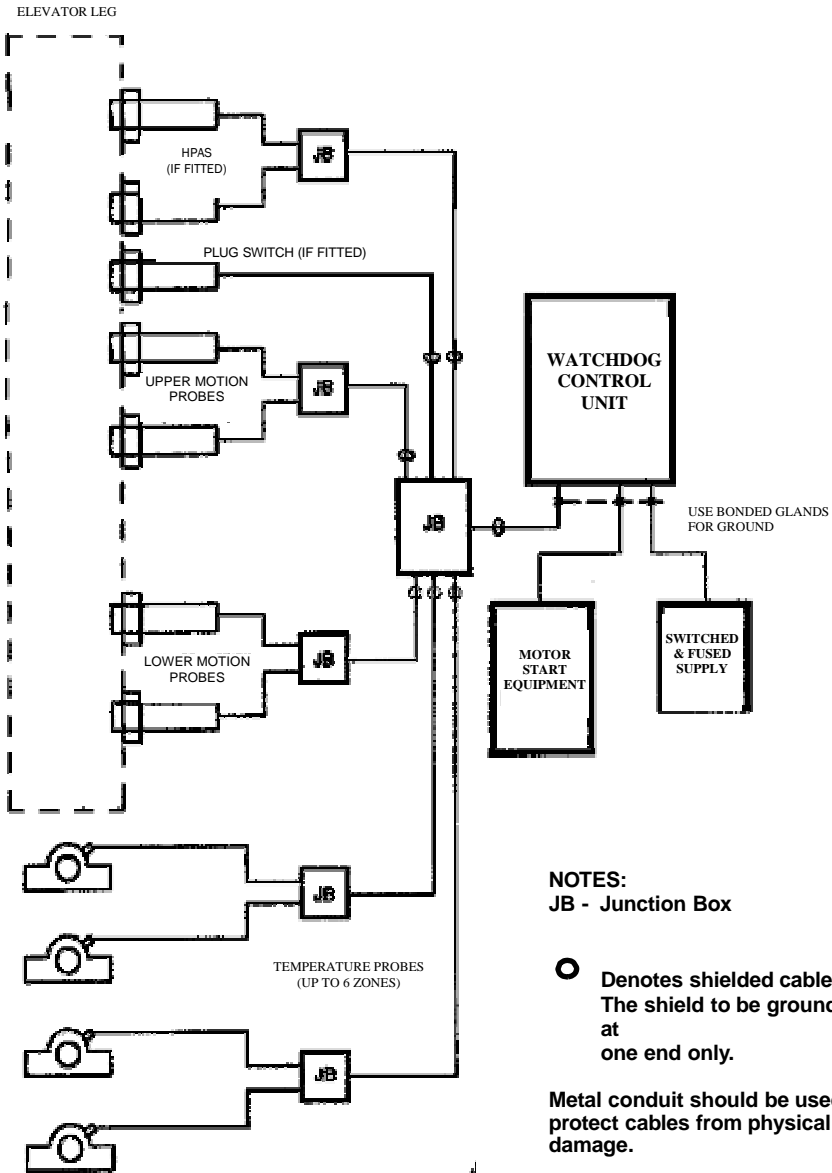

## 3.2 Wiring requirements

- (i) Voltage to Control Unit 100 to 240 VAC 50/60Hz 12 Watts
- (ii) Sensors to Control Unit  
24 Volts DC from Control Unit  
Supply Current 1 Amp MAX  
6-conductor wire shielded

Note: Avoid running cables near any motor wires as this could cause false signals.

## 3.3 Wiring details

### 1. NOTE: Starter Interlock:

In all cases a voltage must be applied across terminals 6 and 7 when the motor is running to establish the starter interlock. See table 1, Electrical ratings. This causes the alarm and stop relays to energise and activates the speed measuring circuit and the start-up delay. When the motor is stopped, the voltage across terminals 6 and 7 should not be present.

### 3.3.1 Diagram I: Control Wiring

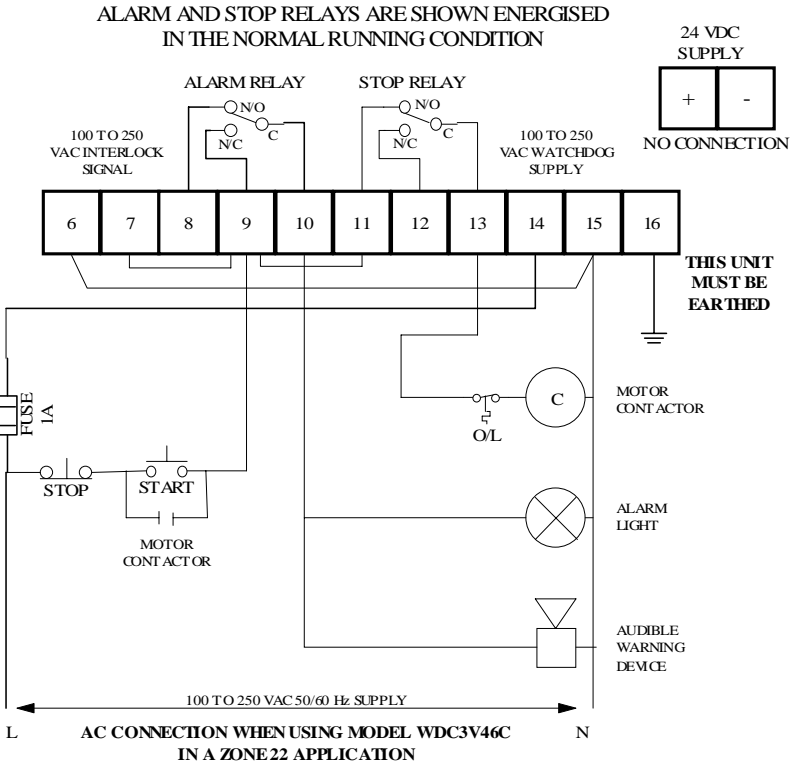



### 3.3.1 Diagram J1 and J2: Sensor Wiring CSA Class II Div 2 Groups E, F & G (Canada) CSA Class II Div 2 Groups F & G (USA)

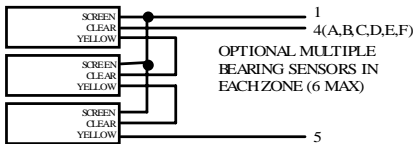
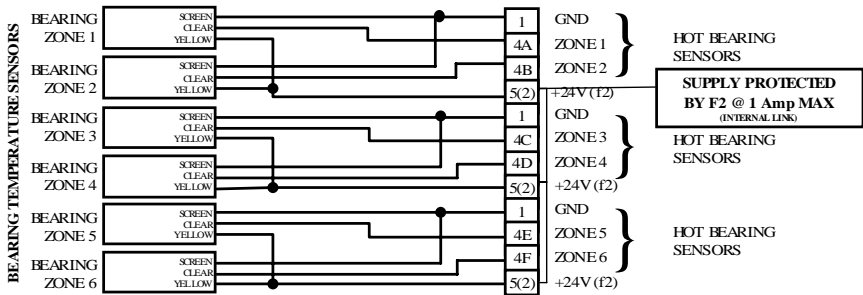
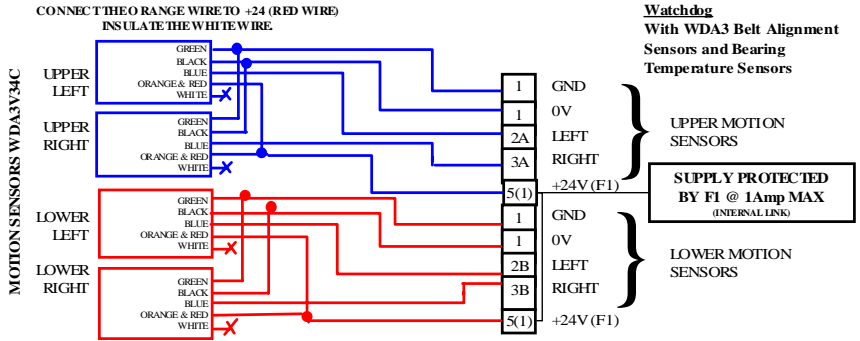

**WARNING:**  
The maximum permitted current for the Watchdog is 1 Amp. This is a requirement of the CSA standard under which the unit operates.

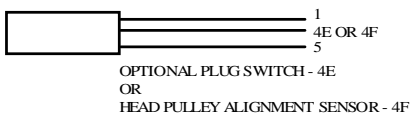

**MOTION SENSOR CURRENT**  
@ 24VDC IS TYPICALLY < 90 ma

**BEARING SENSOR CURRENT**  
@ 24VDC IS TYPICALLY < 8 ma

—X denotes core not connected and should be insulated.

The supply to the external sensors is protected by two fuses. F1 protects the motion sensors and F2 protects the bearing temperature sensors. These fuses are rated as T5R(T) 1 Amp and must only be replaced with identical devices.



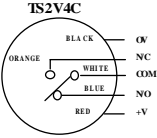

NOTE: THE TOUCHSWITCHES ARE SHOWN IN THE NORMALLY ENERGISED POSITION. WHEN THE BELT MOVES OVER AND ACTIVATES THE TOUCHSWITCH THE CONTACT DE-ENERGISES.

TOUCHSWITCH CURRENT @24 VDC IS TYPICALLY < 60ma

BEARING SENSOR CURRENT @24 VDC IS TYPICALLY < 8ma

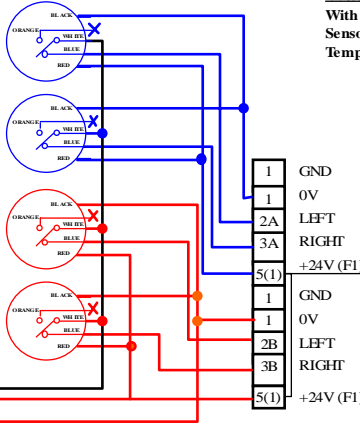
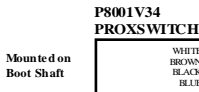

**Watchdog**

With TouchSwitch Belt Alignment Sensors, P800 ProxSwitch, & Bearing Temperature Sensors

HEAD ALIGNMENT SENSORS  
 SUPPLY PROTECTED BY F1 @ 1A (INTERNAL LINK)

TAIL ALIGNMENT SENSORS  
 SUPPLY PROTECTED BY F2 @ 1A (INTERNAL LINK)

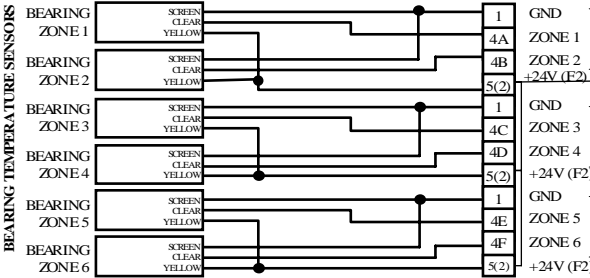

HOT BEARING SENSORS  
 SUPPLY PROTECTED BY F2 @ 1A (INTERNAL LINK)

HOT BEARING SENSORS  
 HOT BEARING SENSORS

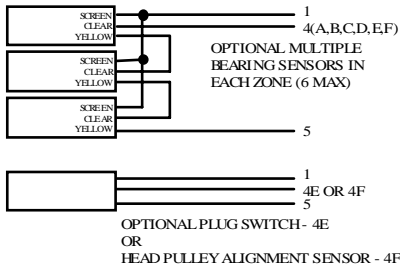

**WARNING:**  
 The maximum permitted current for the Watchdog is 1 Amp. This is a requirement of the CSA standards under which this unit operates.

denotes that this core is not connected and should be insulated

**WARNING:**  
 THE TOUCHSWITCH MISALIGNMENT SENSORS ARE DESIGNED TO IMMEDIATELY STOP THE BELT WHEN THEY ARE TOUCHED BY THE MISALIGNED BELT. THEREFORE THE MISALIGNMENT AND PERSISTENT ALARM DELAY SHOULD BE REDUCED TO ZERO.

**PROXSWITCH Note -**  
 Proxswitch used to generate pulses for speed, and misalignment, through the use of TouchSwitches.

### 3.3.2 Multiple Control Units to a Single Alarm Device

#### WATCHDOG #1

ALARM & STOP RELAYS SHOWN ENERGISED  
IN NORMAL RUNNING CONDITION

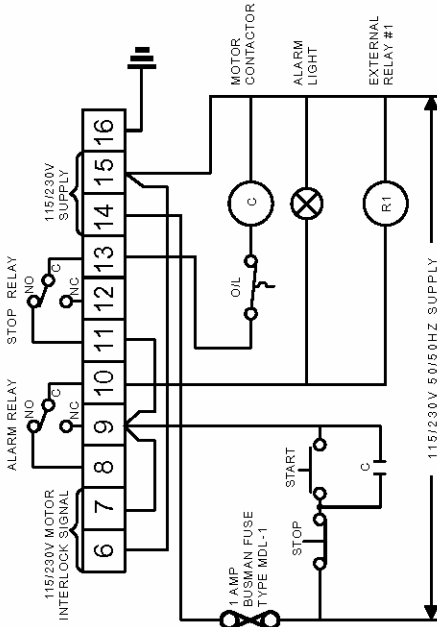

#### WATCHDOG #2

ALARM & STOP RELAYS SHOWN ENERGISED  
IN NORMAL RUNNING CONDITION

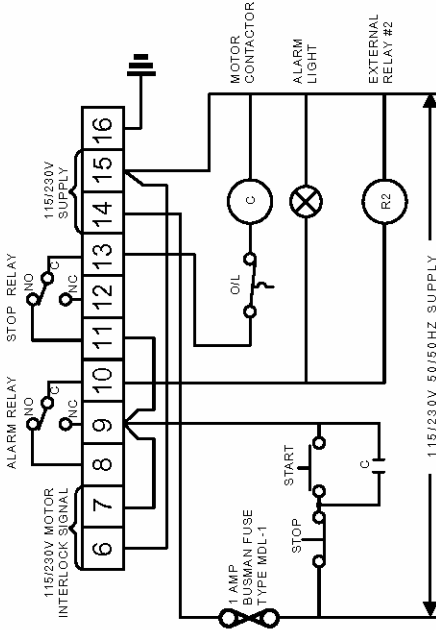

**Important Warning:** To prevent feedback and possible automatic start-up of elevators with Watchdogs connected to a single alarm device, the alarm (terminal #10) must be isolated using an external relay. The schematic wiring diagram on this page shows how these should be wired. (To prevent possible electromagnetic interference, the relays should be external to the control units, installed in a suitable control panel.)

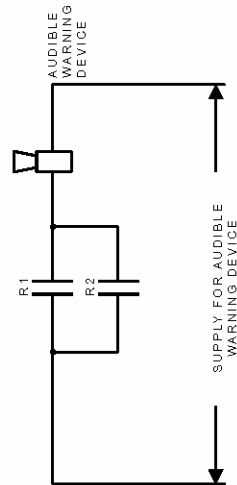

### 3.4 Printed Circuit Board Details

Drawing L

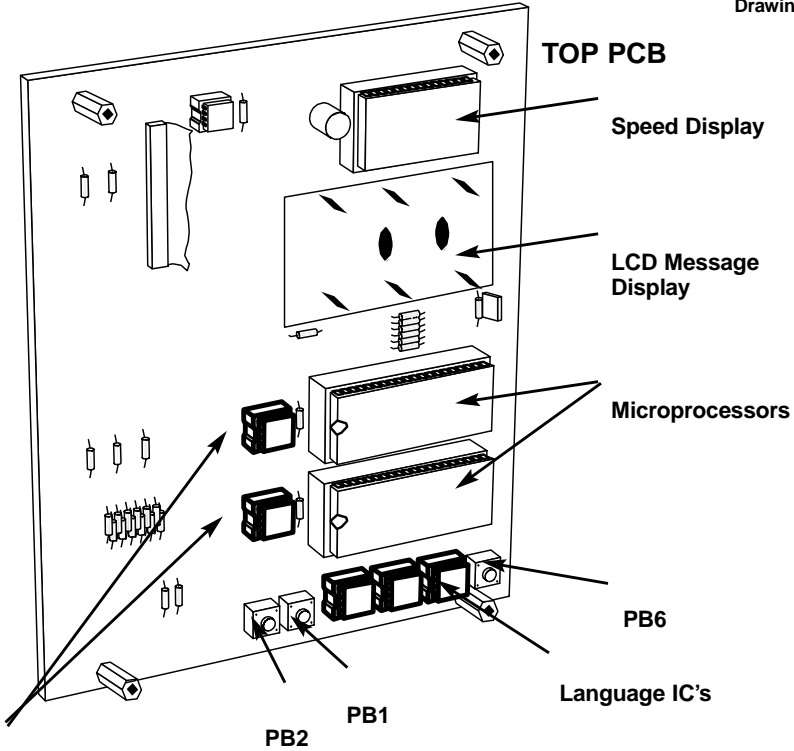

Memory IC's

### BOTTOM PCB

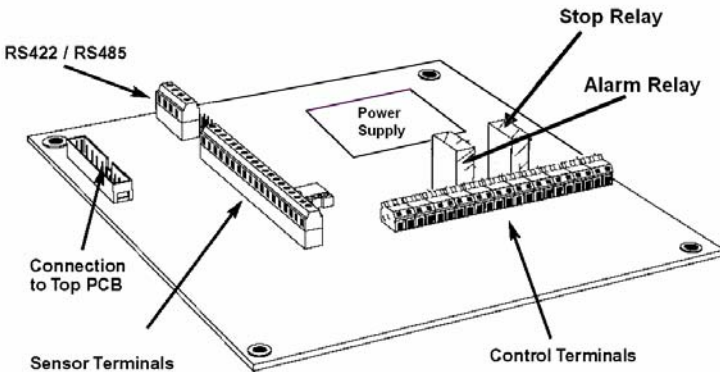

---

## 4 OPERATING INSTRUCTIONS

The equipment should have been installed and wired in accordance with the Installation Instructions (Chapter 2) and in accordance with National and Local Codes.

### 4.1 First time use & Initial Calibration

The Watchdog is normally supplied UNCALIBRATED. When the unit is first connected to its supply this is indicated by a message on the display, "Not Calibrated!... See Manual!" At this time the Alarm lamp should be flashing and the Alarm relay pulsing.

Proceed as follows:-

- (i) Go to the Main Menu by touching button C (green) once. Select the Calibration option by touching button B (yellow) to move the cursor to 'CALIB'.
- (ii) Select 'CALIB' by touching button C (green). Enter the 3-character Calibration access code (A,B,C) that was supplied with the unit. If the code is accepted the LCD will indicate 'Start Elevator to Calibrate'.
- (iii) Operate the START button on the motor starter. This provides an interlock signal to the Watchdog (terminals 6 and 7) which will cause the Alarm and Stop relays to be energised and allow the machine to start. Alarm lamp will continue flashing.
- (iv) The display will indicate the start up delay time. When the start up delay has expired the Alarm lamp will extinguish and the Calibration procedure will start.
- (v) The Calibration procedure takes about 16 seconds, the progress being indicated on the display as a percentage. The Watchdog will measure the rate of input signals from the probes and store an average value of speed (the Calibrated speed) in memory.
- (vi) When the Calibration procedure is complete the unit will go into normal operation. Any change of speed or misalignment or temperature beyond the preset levels will now cause the appropriate ALARM and STOP action. See section 4.4 if it is required to change the preset levels (Watchdog parameters).

**WARNING: A full system test should be undertaken (Section 4.7) before the elevator is used in normal operation.**

### 4.2 Re-calibration

You can re-calibrate the Watchdog at any time whilst the machine is running normally by selecting the 'CALIB' option from the Menu as described above and entering the access code. You are strongly advised against indiscriminate re-calibration, as you may be attempting to calibrate the unit whilst the machine is not running normally. If you have persistent alarm/stop conditions there is either something wrong with the machine or with the adjustment of the system.

If the STOP button is operated on the motor starter (interlock signal removed) during calibration, the Alarm and Stop relays will be de-energised and calibration will be aborted. Calibration will also be aborted if any fault conditions occur, ie the elevator fails to start, or stops during the procedure. To start calibration again if this happens, proceed from (i) above after rectifying the fault condition.

### 4.3 Wrong Calibration

If the unit was calibrated at less than normal speed, it will indicate over-calibration Alarm/Stop conditions and possibly stop the machine when running at normal speed. This indicates that the calibration is wrong and the belt tension should be checked and adjusted as required. The unit should then be re-calibrated (4.2).

If the Watchdog prevents the machine from starting because of wrong calibration, select 'CALIB' from the main menu and enter the CALIBRATION CODE as in 4.1. Wait until the display indicates 'START ELEVATOR TO CALIBRATE' and then start the machine. After a start-up delay the Calibration procedure will begin and when completed the Watchdog will go into normal operation mode. If the Start-up delay is not long enough for the machine to get up to speed then see section 4.4 on how to change it.

---

## 4.4 Setting the Watchdog parameters ('SETUP' mode)

Note that when the Watchdog is powered up it reads the stored 'Setup' parameters from its memory. These will be used during operation. If the Watchdog is new it will have been supplied with 'Default' values. The following paragraphs show how these parameters can be viewed or changed.

Touch buttons and an LCD menu display are provided on the front panel of the Watchdog for making adjustments to the system operating parameters. (See section 1.1)

Normally the LCD indicates the system status, eg. 'READY TO RUN'. Go to the Main Menu by touching button C (green). Move the cursor to 'SETUP' option by using touch button B (yellow). Enter 'SETUP' mode by touching button C (green). The menu will then give the options 'Engineer's setup' or 'Factory setup'

Generally whilst in 'SETUP' mode, touch buttons A & B are used to select an option or to change a value, and touch button C is used to accept or enter the choice. If more than about 30 seconds elapses without a button touch, the menu system will resume displaying status messages.

If the Main Menu is displayed it may be aborted by touching button A (Red).

### 4.4.1 'Engineer' Setup

If 'Engineer' setup mode is selected the Watchdog menu system requests an Engineer's access code: (B,B,B,B). If the correct code is entered then the first parameter (Scale Factor) will be displayed. Sequence through the Setup parameters by touching button C (green). Change values if required by touching buttons A or B and accept by touching button C. At the end of the Setup sequence the option to 'save settings' will be given.

### 4.4.2 'Factory' Setup

In 'Factory' Setup mode a wider range of parameters can be adjusted and generally through a wider range of values. In addition, the 'Engineer's' access code can be changed in this mode. When 'Factory' setup is selected the Watchdog menu system displays a code number. Take note of this number and contact your Supplier for a special access code. Enter this access code and the Watchdog will go to the 'Factory' setup sequence. Note that it will continue to accept the same access code until 'Yes' response is given to the 'Save settings?' request, after which a new code will be required. At the end of the 'Factory' Setup sequence the option to 'save settings' will be given.

## 4.5 Engineer adjustable operating parameters

### 4.5.1 Scale Factor (0.01-99.99) Default setting is "12"

The Watchdog is supplied with the Scale Factor set to 12.00. This value causes the 4 digit numerical display on the front panel to show the measured elevator speed in pulses per minute (PPM) or buckets per minute.

Other units for your installation may be displayed by calculating a new Scale Factor using the following equation:

$$\text{Display} = (\text{Input PPM} \times \text{Scale Factor}) / 12.00$$

$$\text{Therefore: Scale Factor} = (\text{Desired Display} \times 12.00) / \text{Input PPM}$$

The Scale Factor can be altered without affecting the speed calibration or speed trip settings, ie it only changes the numbers which are displayed and not the actual speed.

If at any time the display shows '- - -', this indicates an overrange condition ie greater than 9999. This usually means that the Scale Factor is incorrectly set.

---

There are two special cases for setting the Scale Factor which are useful to know.

- (i) With Scale Factor set at 12.00, the display will show the input Pulses per Minute directly.
- (ii) With Scale Factor set to bucket spacing in inches the display will show the belt speed in feet/minute.

## Worked Examples of using the Scale Factor:

---

### 4.5.1.1 Example 1 - Percentage

If the elevator normal speed is 850 pulses per minute (PPM) and the desired display is 100.0 (%), then Scale Factor =  $(100.0 \times 12.00) / 850 = 1.41$

---

### 4.5.1.2 Example 2 - Tons/Hour

If the elevator normal speed is 420 pulses per minute (PPM) and the desired display is 3000 TONS/HOUR, then Scale Factor =  $(3000 \times 12.00) / 420 = 85.71$

---

### 4.5.1.3 Example 3 - Feet/Min

If there are 9 inches between each bucket and you want to display speed in feet/minute then set the Scale Factor to 9.00

---

### 4.5.1.4 Example 4 - Meters/Min

Scale Factor =  $12.00 \times$  bucket pitch in meters .  
Eg. if the pitch is 23cm, (Scale Factor =  $12.00 \times 0.23$ ) = 2.76

---

### 4.5.1.5 Example 5 - Cubic Meters per Hour

First calculate the normal speed of the elevator in pulses per minute:

If the buckets have 2.9 litres capacity, the speed is 2.5 m/sec and the pitch is 9 per metre, then normal speed is  $2.5 \times 60 \times 9 = 1350$  pulses per minute.

The number of cubic metres per hour at this speed is:

$$2.9 \times 2.5 \times 9 \times 3600 \times 0.001 = 235 \text{ m}^3 / \text{hr} \quad \begin{array}{l} (3600 \text{ Seconds in 1 hour}) \\ (1 \text{ litre} = 0.001 \text{ m}^3) \end{array}$$

So we want the display to read 235 at the normal speed, therefore Scale Factor  
=  $(235 \times 12.00) / 1350$   
= 2.09

Now with Scale Factor set to 2.09, the rate of movement of material in cubic metres per hour can be read directly from the Watchdog speed display.

---

---

#### 4.5.1.6 Example 6 - Metric Tonnes/Hour

Assuming the same elevator as in the previous example, where the standard speed was calculated at 1350 PPM. If the density is 0.752 tonnes per cubic metre, then the number of Tonnes per Hour at this speed is

$$235 \text{ m}^3 / \text{hr} \times 0.752 = 177 \text{ Tonnes/hour approx.}$$

$$\begin{aligned} \text{We want it to read 177 at the normal speed, so Scale Factor} &= (177 \times 12.00) / 1350 \\ &= 1.57 \end{aligned}$$

---

#### 4.5.1.7 Example 7 - US Bushels per Hour (BPH)

The Elevator has one row of buckets each with a capacity of 377 cubic inches; at a 6 inch spacing and with a normal running speed of 600 feet/minute.

$$\text{There are } (600 \times 12) / 6 = 1200 \text{ Pulses per Minute}$$

Now, 1 cubic foot = 1728 cubic inches and 1 Bushel = 1.2445 cubic feet so,

the capacity of the elevator is (buckets/min x bucket capacity x minutes/hour) / (1728 x 1.2445)

$$= (1200 \times 377 \times 60) / 2150 = 12622 \text{ BPH}$$

Note that this is outside the range of the available display, so in this case the Scale Factor can be divided by 10 to give a display of BPH x 10

$$\text{Required Scale Factor} = (12622 \times 12.00) / 1200 \times 10 = 12.6$$

---

#### 4.5.1.8 Example 8 - Cubic Feet per Hour

The Elevator has 2 rows of buckets each with a capacity of 215 cubic inches at 8" spacing and running at 600 feet/second.

$$\text{There are } (660 \times 12) / 8 = 990 \text{ Pulses/minute}$$

$$\text{The capacity of the elevator is } (2 \times 215 \times 990 \times 60) / 1728 = 14781 \text{ cubic feet / hour}$$

$$\text{Again, required Scale Factor} = (14781 \times 12.00) / 990 \times 10 = 17.9$$

Remember that the display will be in  $\text{ft}^3 / \text{hour} \times 10$ .

---

---

#### 4.5.2 **Underspeed Alarm (5-20%) Default setting is 10%**

When the speed of the elevator falls to this value (calibrated speed - underspeed alarm%), the Alarm lamp will illuminate and the Alarm relay will de-energise.

#### 4.5.3 **Underspeed Stop (5-20%) Default setting is 20%**

When the speed of the elevator drops to this value [Calibrated speed - Underspeed stop%], the Stop lamp will illuminate and the Stop relay will de-energise.

#### 4.5.4 **Overspeed Alarm (5-20%) Default setting is 10%**

When the speed of the elevator rises to the value of [Calibrated Speed + 'Overspeed Alarm' %], the Alarm lamp will illuminate. After a delay set by Overspeed Alarm Delay (4.5.16) the Alarm relay will de-energise. This usually indicates wrong calibration (4.3).

#### 4.5.5 **Overspeed Stop (5-20%) Default setting is 20%**

When the speed of the elevator rises to the value of [Calibrated Speed + 'Overspeed Stop %] the Stop lamp will illuminate. After a delay set by Overspeed Stop Delay (4.5.17) the Stop relay will de-energise. This usually indicates wrong calibration (4.3).

#### 4.5.6 **Startup Delay (1-30 seconds) Default setting is 10 seconds**

This is the programmed time in seconds within which the elevator should attain full speed following Start.

#### 4.5.7 **Number of MAS (1, 2, 3, 4) Default setting is "2"**

The number of Motion Alignment Sensors in use on the elevator. (see section 4.8.1)

#### 4.5.8 **Misalignment Sensing (Top or Bottom)**

When "Number of MAS" is set to 3, the user must select where misalignment is to be measured (top or bottom pair of inputs).

#### 4.5.9 **Number of HBS zones (1-6) Default setting is "6"**

The number of Hot Bearing Sensor zones in use on the elevator. There must be a sensor fitted and connected for every zone selected, starting at zone 1.

**Important Note:**

**If this parameter is set to zero then the hot bearing monitoring feature is disabled.**

#### 4.5.10 **Plug Switch, (Yes/No) Default setting is "No"**

If this parameter is set to "yes" then a plug switch should be connected to Hot bearing sensor zone 5 (terminal 4E) this should be wired such that in the normal condition the voltage of this terminal is 24V, dropping to 0V when the plug condition occurs

#### 4.5.11 **Head Pulley Alignment Sensor (HPAS), (Yes/No) Default setting is "No"**

If this parameter is set to "yes" then a Head Pulley Alignment Sensor should be connected to hot bearing sensor zone 6 (terminal 4F) this should be wired such that in the normal condition the voltage at this terminal is 12V, dropping to 0V when the fault condition occurs.  
(See data sheet WDD 1.7)

#### 4.5.12 **Comms ID (RS422/RS485) (1-32) Default setting is "1"**

This is the identification number that will be used by a host computer when communicating with the Watchdog. If more than one unit is connected on a 'multidrop' serial link then they must each have a different value for this parameter. A maximum of 32 Watchdog units may be connected to a multidrop serial link.



---

## 4.6 Factory Adjustable Operating Parameters

(To access these parameters, see section 4.4.2.)

### 4.6.1 Engineer Code

The Engineers Code can be changed for safety/security reasons.

### 4.6.2 Acceleration Monitoring, (Yes/No) Default setting is "Yes"

This parameter allows Acceleration Monitoring to be "switched off." Whilst disabled in this way, the Watchdog will not respond to any type of underspeed condition during the start-up delay period.

### 4.6.3 Stop on Hot Bearing, (Yes/No) Default setting is "No"

If enabled, this parameter allows the Watchdog to stop the elevator almost immediately when a hot bearing condition is detected. If disabled the elevator will be stopped after "persistent alarm" seconds.

### 4.6.4 Type of Thermistor (PTC/NTC) Default setting is "PTC"

Analogue NTC Thermistors can be used to display the individual bearing temperature. (See data sheet WDD 4.6.4)

### 4.6.5 Speed Range (2000/4000) Default setting is 2000 ppm

For high speed elevators or very closely spaced buckets the speed range can be increased to 4000ppm.

### 4.6.6 Smoothing Factor (1-32) Default setting is 10

Increasing this parameter improves the Watchdog's immunity to instability of the measured speed and therefore lessens the possibility of false or nuisance alarms and shutdowns. It should be remembered that a high value of Smoothing Factor will tend to reduce the response time of the Watchdog to a sudden change in speed, which may be undesirable. If the elevator has unequally spaced or missing buckets the Smoothing Factor will have to be set to a higher value.

### 4.6.7 Misalignment Delay (1-30 seconds) Default setting is 6 seconds

This is the time in seconds following misalignment detection that the Alarm Relay will be de-energised. Note that the Alarm Lamp illuminates as soon as a misalignment is detected.

### 4.6.8 Misalignment Ratio (20-80%) Default setting is 66%

A misalignment condition exists if the speed measured from the probes on one side of the elevator is less than 'Misalignment Ratio' percent of the speed on the other side. Therefore increasing this value increases the magnitude of permissible misalignment.

### 4.6.9 Persistent Alarm Delay (0.1 - 240 seconds) Default setting is 180 seconds

If any alarm conditions exist, (ie the Alarm Lamp is on) for a period which accumulates to more than the 'Persistent Alarm Delay' seconds, then the Stop relay will be de-energised.

### 4.6.10 Relay Delay (0.1 - 10 seconds)

This is the time delay in seconds before the Alarm relay de-energises following :-

- (i) detection of a 'hot bearing' condition
- (ii) detection of a 'misalignment' condition.
- (iii) detection of speed less than the 'underspeed alarm' limit

It is also the delay in seconds before the Stop relay de-energises following:-

- (i) detection of speed less than the 'underspeed stop' limit

### 4.6.11 Overspeed Alarm Delay (1-10 seconds) Default setting is 10 seconds

This is the time delay in seconds before the Alarm relay de-energises following detection of an 'Overspeed alarm condition.'

### 4.6.12 Overspeed Stop Delay (1 - 30 seconds) Default setting is 20 seconds

This is the time delay in seconds before the Stop relay de-energises following detection of an 'overspeed stop condition.'

---

## 4.7 The Test Function

To perform a test, go to the main menu by touching the button "C" (red). Select "TEST" from the main menu. Two options will be displayed, "Test Settings" and "Full Test".

### 4.7.1 Test Settings

When selected, the test will show the value of the calibrated speed and the actual alarm and stop trip speed settings in pulses per minute on the speed display and the trip percent-ages on the message display. This test can be performed at any time whether the machine is running or stationary, as the relays do not operate from this test function and the normal running of the machine is unaffected.

### 4.7.2 Full Test

**WARNING: This test will deactivate the alarm and shut down relays which will shut down the elevator. The elevator must be empty and clear of all products when performing this test.** When the full test is selected, the engineer's access code will be requested. (see 4.4.1) When the access code is entered, the settings will be displayed as the "Test Settings", and in addition the alarm relay and then the alarm and stop relays will be de-activated, thus verifying the relays and external wiring. It is recommended that these tests are performed on a regular basis in order to verify correct working of the system, the external wiring, and related components. Abort test by touching button "A".

**WARNING: A full test should be performed on a regular basis and should be included in the preventative maintenance program for the elevator.**

## 4.8 Normal Operation

### 4.8.1 Motion Probe connections and Probe Led's

The Watchdog can be used with 1 to 4 motion probes (MAS). The number of MAS is a user selectable parameter in the 'SETUP' sequence. Diagram J shows which terminals are used for the motion probes. Each probe input has a corresponding green LED on the front panel of the Watchdog. The LED will flash when the probe connected to its input detects a bucket or bolt. For clearer indication of pulse consistency the flash rate of the Led's is limited to a maximum of 300PPM (or 5 per second), although the actual input pulse rate can be 4000 PPM.

#### 1 Probe System:

The probe can be connected to any input and the Watchdog will monitor speed only.

#### 2 Probe System:

The probes are connected to the top or bottom pair of inputs. The Watchdog indicates the highest speed measured at the two inputs. Belt misalignment is also detected.

#### 3 Probe System:

The user selects where misalignment is to be measured (top or bottom pair of inputs). The third probe is connected to one of the unused inputs and the Watchdog automatically uses this probe **only** for measuring speed.

#### 4 Probe System:

The probes are connected to all four inputs. Misalignment can be sensed at the top and/or bottom of the elevator. The Watchdog measures the speed at each probe and indicates the highest value found.

#### Summary of Motion/Misalignment sensing options

TABLE 11

No of MAS	Speed Sensing input	Misalignment Sensing input
0	Inactive	Inactive
1	Upper or Lower L or R	Inactive
2	Upper or Lower L & R	Upper or Lower L&R
3	Upper or Lower L or R	Upper or Lower L&R
4	Upper & Lower L & R	Upper & Lower L&R

---

## 4.8.2 Starting and Accelerating

As soon as the motor interlock input is energised to show that the elevator motor has started, the start up timer begins to time out. When this time has expired, the input speed is compared to the Calibrated Speed and if it is within the preset limits, no action is taken.

During start-up conditions the UNDERSPEED detector is inhibited but the ACCELERATION of the elevator leg is monitored to ensure that any belt slip is immediately detected.

The Watchdog uses the system parameter,- 'Start-up Delay' (seconds) to determine the expected speed at any time during the start-up period. If the elevator fails to move at all, or if the speed is less than expected at any time then the Watchdog will trip the STOP and ALARM relays and display 'STARTING FAULT'.

## 4.8.3 Underspeed Detection

If the belt speed falls below the Underspeed Alarm trip speed , the Alarm lamp will illuminate and a timeout counter will begin counting down from the value of 'Relay Delay' seconds. If the underspeed condition persists when this timer times out then the Alarm relay will de-energise to provide the appropriate warning.

The status message on the display will be 'BELT SLIPPING'. If the speed falls further, below the Underspeed Stop trip speed, the Stop lamp will illuminate; a timer will begin a countdown from 'Relay Delay' seconds; and again, if the underspeed condition persists when the timer times out then the Stop relay will de-energise to stop the motor.

Note that until the Stop relay has been de-energised, the system can recover from under-speeding conditions if the speed returns to a higher value.

When the motor stops the display will show 'STOP CONDITION' and 'UNDERSPEED FAULT' and the Stop lamp will remain lit

## 4.8.4 Overspeed Detection

The Watchdog overspeed function informs operators of an incorrectly calibrated unit. This could happen if a unit is calibrated whilst the belt is slipping.

When the belt speed rises above the Overspeed Alarm trip speed the Alarm lamp will illuminate; the Overspeed Alarm Delay timer will begin counting down and the status messages will reflect this. If the overspeed condition persists when the timer times out the Alarm relay de-energises, and the status message will be 'OVERCALIBRATION'.

If there is a further increase of speed to a level above the Overspeed Stop level then the Stop lamp will illuminate; the Overspeed Stop Delay timer will begin counting down; and the status message will show the timer value. If the Overspeed stop condition persists when the timer times out then the Stop relay will de-energise to stop the motor.

Note that until the Stop relay has been de-energised, the system can recover from over-speeding conditions if the speed returns to a lower value.

When the motor stops the display will show 'STOP CONDITION' and 'OVERCALIBRATION' and the Stop lamp will remain lit.

---

## 4.8.5 Misalignment Detection

The Watchdog senses misalignment conditions from a pair of motion probe inputs. In a system with two probes, either the upper or the lower inputs are used for sensing misalignment. In a four probe system the unit senses misalignment from both the upper and lower pair of probe inputs.

If the input signal rate from one of the probes should cease (or fall to less than 'Misalignment Ratio' percent of the rate of the other probe) this is treated as a mis-alignment condition. If this condition persists for more than about 2 seconds, the Alarm lamp will illuminate and a timer will begin counting down from 'Misalignment Delay' seconds. the display will show "MISALIGNMENT" and the location "TOP" or "BOTTOM". If the misalignment condition persists when the timer times out the Alarm relay will de-energise to provide the appropriate warning. The misalignment condition will also be indicated by the display. If the misalignment condition ceases the Alarm relay will energise and the Alarm lamp will be extinguished.

## 4.8.6 Bearing Over-Temperature Detection

Bearing temperature sensing is selected by setting the system parameter,- 'No of HBS zones' to a value between 1 and 6. A bearing sensor must be fitted for each of the zones selected and connected to the relevant HBS zone inputs on the Watchdog. If 'No of HBS zones' is set to zero then hot bearing sensing is inactive. If the temperature of a bearing sensor connected to one of the selected zones rises above its trip point, the Alarm lamp will illuminate. If this condition persists for more than about 2 seconds the Alarm relay will de-energise to provide the appropriate warning. If a hot bearing condition persists, the display will show 'HOT BEARING ZONE x'.

## 4.8.7 Persistent Alarm Conditions

If the Alarm lamp is illuminated because of UNDERSPEED, OVERSPEED, MISALIGNMENT or HOT BEARING conditions, and the condition has persisted for more than 'Persistent Alarm Trip' minutes, then the Stop lamp will illuminate and the Stop relay will de-energise to stop the elevator motor. If the alarm condition persists for less than 'Persistent Alarm Trip' minutes and is then cleared, the amount of alarm elapsed time is stored in memory. This elapsed time is cancelled after an equal time without any alarm condition. Consequently, if the alarm condition is intermittent, but no single interval of alarm exceeds persistent alarm trip, the persistence of the alarm can eventually result in a STOP condition.

If this happens, the display will show 'STOP CONDITION' PERSISTENT ALARM, (see section 4.8.8).

The following example will serve to illustrate this useful function as it shows how a STOP condition can be caused by a number of Alarm conditions existing over a period of time..

Example: 'Persistent Alarm Trip' is set to 3 minutes (see section 4.6.9) :-

Condition	Elapsed time	
Underspeed Alarm for 2 minutes	2 Mins	
No alarm for 0.5 minutes	1.5 Mins	
Misalignment Alarm for 1 minute	2.5 Mins	No
alarm for 1 minute	1.5 Mins	
Misalignment and Hot Bearing for 1.5 minutes	3 minutes	
	STOP!	

### NOTE:

**A SHUTDOWN will stop the elevator motor dependent upon the interlocking stopping circuit. When the motor is restarted, the Alarm elapsed time is cancelled. Short persistent alarm conditions will cause the relevant lamp to flicker on and off without de-energising the Alarm or Stop relays. This can serve as a warning that elevator maintenance may be required.**

---

## 4.8.8 Stop (Shutdown) Conditions

When the Watchdog is in a 'Stop' condition, the Relays are de-energised and the Stop lamp is illuminated. The alarm lamp will also be illuminated if a HOT BEARING condition persists. A status message will be indicated on the display which consists of 'STOP CONDITION' on the upper line and the following text on the lower line:-

Status	Description
STARTING FAULT	Elevator belt failed to maintain acceleration during start up or failed to move at all. Check that the system parameter,- 'Start-up Delay' is long enough and that there are no blockages in the elevator leg before attempting a re-start.
OVERCALIBRATION FAULT	i.) Speed exceeded 'Overspeed Stop' percentage increase on Calibrated speed for a duration longer than the 'Overspeed Stop Delay' seconds. ii.) Persistent 'Overspeeding' above Alarm percentage has occurred.
UNDERSPEED FAULT	i.) Speed was less than 'Underspeed Stop' percentage decrease on Calibrated speed (for a duration longer than 'Relay Delay' seconds.) ii.) Persistent 'Belt Slipping' has occurred, (speed is less than the underspeed alarm level). iii.) Check belt tension and recalibrate while the elevator is running empty.
PERSISTENT ALARM	Alarm conditions have accumulated for more than a duration set by 'Persistent Alarm Time' seconds. Can be caused by any combination of Over/Underspeed, Misalignment, Hot bearing, Plug Condition and Head Pulley Alignment alarm conditions.

If more than one condition caused the STOP, the status messages will be indicated in sequence.

## 4.8.9 Power-fail Conditions

If the power supply to the Watchdog is removed, the Stop and Alarm relays will de-energise. The Calibrated Speed and the setup parameters remain stored in memory.

---

## 5 QUICK CHECKLIST

### For problems after initial start-up

1. Are all the buckets in the elevator ferrous (steel) or non-ferrous (plastic, urethans or stainless steel)? If magnetic, ie steel, the motion probe should be directed at the bucket as in drawings 'B' and 'C'. If non-magnetic, the motion probe should be directed at the steel bolt heads as drawings 'D' and 'E'.
2. Are all the buckets present on the belt (none missing) and equally spaced?
3. Is there excessive interference on the electrical power supply? Power conditioners and surge (spike) suppressor may have to be fitted.
4. Is the motor interlock wired correctly and is the correct interlock voltage present when the motor is running? (Terminals 6 & 7)
5. Has the Watchdog been calibrated.
6. Has the wiring for the probes been routed away from power cables? See paragraph 2.2. & 2.3.
7. Are the probes mounted away from plastic abrasion liners (which could cause static interference), electric motors and other magnetic fields?
8. Is the Watchdog circuit properly grounded?
9. Is the elevator leg grounded to prevent static build-up?
10. Is the belt in good condition and running true?
11. Does the belt stay in alignment when material is fed into the elevator leg?
12. Is the elevator leg belt tensioned sufficiently to prevent belt slip?
13. Check that there is no tramp metal in the intake, no loose head pulley lagging, and no loose abrasion liners.
14. Have the probes been mounted properly, rigidly and free from vibration?
15. Check that the probes do not come in contact with the buckets or the bolts.
16. If sensing on the bolt heads, are the probes positioned on the outside of the bolt heads as drawing 'D' and 'E'?
17. Is the Micro-processor control unit overheating, if so mount in temperature-controlled environment of maximum ambient temperature 104°F (40°C).
18. If the elevator bucket bolts are non ferrous (stainless steel), insert mild steel fender washers between the belt and buckets as targets.
19. Check that high powered 'Walkie Talkie' radios are not operated near the Watchdog control unit or probes, as this may affect the performance.
20. If your bucket elevator has a weighted take up please contact '4B' to ensure sufficient weight is placed upon it (especially when changing from steel to plastic buckets).
21. If the "Watchdog" is used in conjunction with a PLC (programmable logic controller) it is possible for a residual voltage to appear across terminals 6 and 7. Contact '4B' if this occurs.
22. If after 5 seconds, the Watchdog display fails to power-up, then check the supply voltage and external fuse.

## 6 FAULT FINDING CHART

	SYMPTOM	CAUSE	REMEDIAL ACTION
1	LED on Motion Probe	Probe too far away from buckets Probe adjustment incorrect Wiring connection faulty	Move probe closer to bucket if possible does not flash Turn screw clockwise to increase sensitivity Check wiring
2	LED on motion probe excessively	Probe too close to buckets Probe adjustment incorrect Interference in wiring Probes require adjustment	Move probe away from buckets flashes Turn screw counter-clockwise Use shielded cable and rigid conduit See Section 1.2
3	Probe LED on Control unit does not flash	Elevator is not running. Motion probe not operating. Wiring Fault. Probes connected to-wrong terminals.	See section 1 above and Table 4  Check wiring
4	Wrong probe LED on unit flashes	Motion probe connected to wrong input.	See Section 4.8.1
5	Alarm LED on	Hot Bearing Belt Misaligned Belt Slipping Overspeeding Alarm trip settings incorrect	Check all bearings Check belt Check belt, tension Check calibration Refer to section 4.4 (setup procedure)
6	Stop LED on	Stop condition occurred settings incorrect	See section 4.7.8 (Stop conditions) Stop trip Refer to section 4.4 (setup procedure )
7	Speed display unstable	Probe adjustment required Missing buckets/bolts	See 1 & 2 above Replace
8	Speed display is ' - - - '	Overrange ie greater than 9999	Set Scale Factor (section 4.5.1)
9	Speed display incorrect	Scale factor incorrectly set	Set Scale Factor (section 4.5.1)
10	Elevator fails to start	Interlock faulty, Interlock supply remains on following Stop condition Watchdog unit not powered up.	Check wiring Press Stop button then Start button Power up Watchdog
11	Elevator starts but fails to keep running.	Start-up time too short Incorrect calibration. Motion probe not adjusted. Belt slipping	Increase Start up Delay (section 4.5.6) Check belt speed & re-calibrate See 1 & 2 above Check belt speed & re-calibrate
12	Alarm relay pulsing & Alarm lamp flashing	Watchdog uncalibrated or waiting to start calibration	See section 4.1 on Calibration procedure
13	Power on, but unit does not work	Microprocessor may be in wait condition. Fuse Blown	Switch off power for a short time then switch on Check Wiring and fuse
14	Calibration fails	Motor failed to start  Speed exceeded 2000 PPM with speed range set to 2000	Check connections to motor Check for blockages in elevator  Check required speed range

## 7. WARNING MESSAGES DISPLAYED ON LCD

TEXT ON LCD	CAUSE	ACTION (where required)
'Not Calibrated'	Watchdog Not calibrated	Calibrate (Section 4.1 – Page 26)
Start Elevator Calibrate	Calibrate option has been selected from menu	Start Elevator to
Hot Bearing	Bearing at Zone x has exceeded temperature	Check the bearing at Zone X Zone x Check wiring for fault
HBS open circuit Zone x	Bearing sensor faulty or wiring faulty	Check bearing sensor & wiring at Zone x
Misalignment Upper/Lower	Belt is misaligned at top or bottom	Check elevator belt Check MAS (Section 6 – Page 37)
Underspeed Alarm Delay in seconds Slipping'	Elevator belt is slipping Incorrect calibration	Check the belt tension Check the belt speed and re-calibrate or 'Belt
Overspeed Alarm Delay in seconds or Overspeeding	Incorrect Calibration	Check the belt speed and re-calibrate
Plug Condition Pulley Misalignment Denied Manual !	Spout is Plugged Head Pulley is Misaligned Wrong Setup access code was entered. Wrong Calibration access code was entered.	Check for blockage in spout Head Check head pulley alignment Access Try again or consult supplier See
Internal Fault Code n	Watchdog internal fault	Contact supplier
Power_Fail	Supply voltage out of limits	Check supply voltage See Table 1 - Electrical ratings
MAS Fault /Lower	Mains Interference on MAS Probe signals. Cal speed is more than 2000PPM and Speed Range = 2000.	Use shielded cable & Upper rigid conduit Set Speed Range to 4000
Stop Condition Fault	Elevator failed to accelerate	Check elevator leg. Starting  Check motor starting circuitry Check condition of "soft start" system
Stop Condition Underspeed Fault	Elevator speed was below preset value	Check belt tension Check belt speed
Stop Condition Overcalibration Fault	Elevator speed was above preset value	Check belt tension Check belt speed and recalibrate
Stop Condition Persistent Alarm	One or more alarm conditions have persisted	Check and remedy problem.
Stop Relay Open Speed n	Waiting for motor to stop	None
Motor Running Speed n	Normal Running	None

**Note:** In all cases, immediately stop the elevator before investigating any problem. Ensures that all lock-out and tag-out procedures are adhered to.



---

## 8 LIABILITY AND INDEMNITY

- 1) In respect of installation or applications of the goods as parts or components of other goods or machinery the buyer shall be solely responsible for the compliance and the installation with safety regulations issued by competent authorities and in force at the place of operation and / or for its compliance with any terms of insurance notified by the Buyer's insurance for personal injury or damage to property or loss of profit through fire, explosion, gas or otherwise.
- 2) Neither the Company nor its suppliers shall in any circumstances whatsoever be liable for any loss or damage suffered by the Buyer or by any third party howsoever caused involving any person, property or interest, suffered by the Buyer or any third party directly or indirectly in connection with the use, functioning or state of the goods, unless the same shall arise out of the Company's negligence.
- 3) The Buyer shall indemnify the Company against all actions, claims or demands by third parties, whether in tort or otherwise, howsoever arising, directly or indirectly, in connection with the use, functioning or state of the goods or inconnection with the performance of service.

### Limitation of Liability

Without prejudice to the foregoing, the Company shall in no circumstances be liable:-

- 1) For any incidental or consequential loss or damage suffered by the buyer, including, with- out limitation, delay, detention, loss of production, loss of profit or liability to third parties except liability for personal injury or death arising out of negligence by the Company.
- 2) For any loss or damage covered by insurance or which would ordinarily be covered by insurance.

### Warranty

The equipment is covered by 24 months warranty from the date of despatch. Any faults arising due to faulty materials or workmanship in the original equipment within the warranty period will be corrected free of charge providing the equipment is returned to us freight paid.

## Watchdog Elite - M/A PROBE MOUNTING BLOCK TEMPLATE

Photocopy this template and use for marking out holes for the mounting blocks.

The mounting block is made from 1" thick high-density polyethylene and is supplied with a 5/16" x 4 1/2" long zinc-plated clamping bolt and lock nut

**PLEASE REFER TO THE TEMPLATE ADDENDUM FOR  
THE MOUNTING TEMPLATE.**

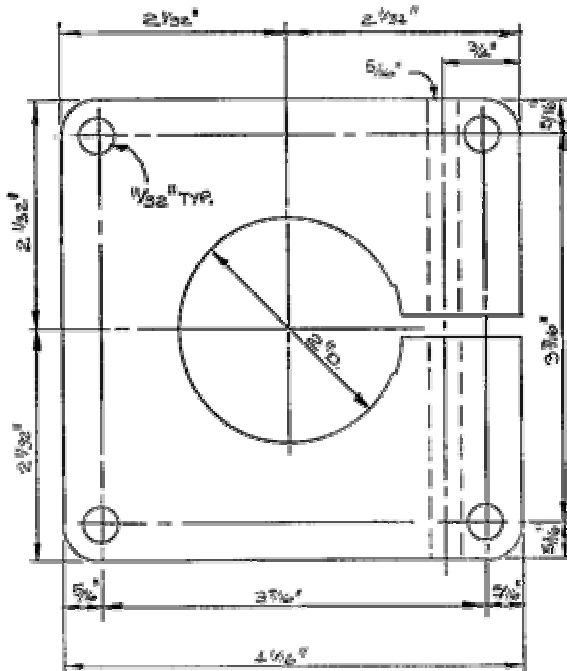

**NOT TO SCALE  
PLEASE USE SEPARATE TEMPLATE**

## Zones of use of WDC3V46C Watchdog Elite:

CSA(cus) for use in Zone 22

### Certification Markings:



CLASS II, DIVISION 1, GROUPS E, F, & G (CANADA ONLY)



CLASS II, DIVISION 2, GROUPS F & G (USA ONLY)

### To Open the Lid:

1. Disconnect power (isolate ALL circuits)
2. Untighten the lid securing screws
3. Carefully open the lid ensuring that the gasket is not damaged and remains in place

### To Close the Lid:

1. Check that the gasket is correctly fitted into the box groove and is undamaged.
2. Tighten the lid screws.
3. Check that the lid and box are correctly mated.

### Enclosure Installation:

- a. The IP66 rating of the enclosure must be maintained when used in Zone 20 and 21 dust environment. You must use the correct cable, glands and sealing arrangement and in accordance with the installation codes detailed in the appropriate standards.
- b. Where other certified components are used as part of the assembly or installation procedure, the user must take in to account any limitations which might be listed on the relevant certificates.
- c. The box is supplied with 2 pre drilled holes in the bottom face. All unused entry apertures must be sealed using component certified stopping plugs as recommended under the standard. The end user must install component or apparatus certified stopping plugs and cable glands in strict accordance with the manufacturer's instructions.
- d. The enclosure must not be modified in any way without reference to the manufacturer, as this will invalidate the certification.
- e. All wiring must be carried out in accordance with relevant national electrical codes or instructions.
- f. The voltage and current and maximum power dissipation shown on the box label must not be exceeded.
- g. The wiring insulation must extend to within 1 mm of the metal face of the terminal.
- h. All leads must be insulated for the appropriate voltage.
- i. Not more than 1 single or multiple strand cable is to be connected to any terminal unless multiple conductors have previously been joined in a suitable manner (e.g. boot lace ferrule) such that they present a single connection point to the terminal.
- j. A parallel shaft screwdriver of the correct size should always be used when tightening terminals.