

Information Guide & Tips for the Installation of a T500 Hotbus Elite Communications System



The communications system used on the T500 Elite and the TN4/TN4e sensor nodes is known as Hotbus. The system is based upon a 2 wire RS485 serial communications interface. The purpose of this document is to provide information and tips to assist in a simple and easy error free installation of the system. However it is not intended as a substitute for the installation and set-up instructions provided with the system.

Hotbus is known as a linear topology bus, this simply means that the communications must effectively be in a straight line and only have two ends (Fig 1). The cable doesn't literally have to be in a straight line but more like a coiled piece of wire which can be unraveled into a straight line and only has two ends (Fig 2). Branches and tees are not normally allowed as part of the installation (Fig 3). It is good practice to plan your cable route before beginning the installation. Fig 5 shows how the cable is daisy chain connected between the nodes. The nodes can be connected in any order and the T500 can be connected at any point on the network, this also applies to the optional R500 relay interface units. Refer to the unit manuals for further connection details.

The maximum cable length on the Hotbus system is 3000 ft without repeaters. To achieve these lengths, good installation practice is required and the correct cable must be used. Below are a few areas of advice to help achieve optimum system performance.

- Plan the cable route in advance of the installation. If possible, include termination boxes where the communication cable can be easily accessed for any future expansion of the system.
- You **MUST** use the correct communications cable type Belden 9841 (Twisted pair, 24 AWG, shielded, industrial RS-485) or equivalent. Two standard **14 AWG** stranded copper cables can be used for the 24 VDC node/sensor power.
- For the communications to work correctly the communications cable requires two 120 OHM $\frac{1}{2}$ watt termination resistors (included). These resistors should be connected across A and B on the communications cable terminals. If the T500 control unit is installed at the start or end of the communications cable then connect one resistor across A and B in the T500 and the other resistor across A and B in the last node. If the T500 is not at the start or end of the communications cable then connect one resistor across A and B in the first node and the other resistor across A and B in the last node. Failure to install termination resistors correctly can result in poor communications.

Professional Tip # 1 ✓

The resistance of each node across A and B terminals is 265K-Ohm approx. So when all nodes are connected to the communication cable, all their resistances are in parallel. So total resistance in K Ohms is 265/total number of nodes.

Example: The total resistance across A and B on a network with 28 nodes is:

$$265/28 = 9.46 \text{ K Ohms}$$

IMPORTANT: This test is done without the two 120-Ohm termination resistors connected. But remember to install the resistors when the test is complete.

- You will need to use a separate 24Vdc power supply to meet your power needs for sensors and nodes. This power supply should be correctly rated and must have its output protected by a separate fuse link, which is correctly rated for the system. Most power supplies today have inbuilt protection but they are rated at the full power rating so an external fuse will provide better protection for the system.
- The Hotbus communications and power cables should be installed in a conduit or cable tray without other cables. The twisted pair communications cable is effective at eliminating interference from external sources but as the cable length increases so does the effects of interference. If it is not possible to install the cable in this way you should ensure that the cable is not installed in an area where electrical interference can be a problem. High voltage cables, high current cables, high frequency cables such as Variable Frequency Drives and microwave driers are all potential sources of interference for the Hotbus system and you should avoid using existing cabling routes if they contain any of the above.
- Do not install the Hotbus cables, the T500 Control Unit, or any of the Nodes near radio transmitter aerials or cellular telephone repeaters.
- You CAN install the Hotbus cables along with other communications cables such as Ethernet.
- Conduits, cable tray and trunking should be correctly bonded and grounded.
- The communications cable carries a foil and trace/drain wire shield. **The trace/drain wire should be separated from the foil twisted with the trace/drain wire on the adjacent communications cable, and taped off to insulate it from touching any other conductors. The foil should be cut back and insulated.** It is important to ensure that the shield connection is maintained throughout the installation. Connect the shield wire to ground at the T500 only. You must not allow the shield wire to come in contact with a ground source at any other point as this could significantly increase electrical noise by inducing ground currents.

*Note: The 0V connection on the T500, R500, & F500 control units are internally linked to the ground terminal. The shield should **not** be connected to the 0V terminal at the R500 or F500.*

Professional Tip # 2 ✓

When installation is complete, but before connecting the shield to ground at the T500 control unit, there should be an open circuit/infinite resistance measured between the shield and ground.

- The ground used for the system must be a clean ground. Avoid using the same ground as high power cables or those belonging to a VFD or similar high frequency device. An instrument grade ground connection is preferred.
- When connecting the wires to the node connectors ensure that there are no loose wire ends, which could cause a short between connections or between a connection and ground.
- The power supply to the T500 must be 115 VAC/230 VAC $\pm 10\%$ or 24VDC $\pm 10\%$ and a good ground connection must also be used. If the power is fed from an electrically noisy supply you must install additional noise filters or power conditioning components.
- Before applying power to the system check that the connections are ok. It is cheaper and quicker to check for faults now than to repair or replace faulty TN4 nodes because of a wiring error. A common fault is to cross over power and communications wires resulting in the failure in one or ALL of the nodes on the system.

Quick Tip # 1

When entering node addresses in the T500 control unit, it is usually easier to enter them one by one and check that there is communication on the most recent node entered. The Green LED on the node should be flashing when the node is communicating.

Most common problems experienced on installations can be avoided by using good wiring practices. Keep connections neat; observe correct shielding and grounding practice and choose the cable route carefully.

Quick Tip # 2

It is important to keep track of the node addresses on all systems and completing a table similar to the “Sensor Name Chart” shown on the last page will help.

Quick Tip # 3

One of the common problems with conduit systems is the ingress of water. Many electricians understand that no matter how well a conduit system is installed, at some stage a cover could be left loose or condensation can accumulate. This moisture can be channeled to sensors and over time can accumulate and eventually damage the wires or sensor. As such, low conduit drains, approved for the location should be installed and sensor wiring should be “Teed” with an adequate wiring loop so that water following the wires is not channeled to the sensor (Figure 8). Part of the regular system maintenance should include the cleaning of any accumulated debris from around the conduit drains and the inspection of conduit systems for water ingress.

Quick Tip #4

We recommend scheduling your annual inspection / testing with 4B beginning with the commissioning of the system. Contact our office to request a quotation or learn more information about this important service.

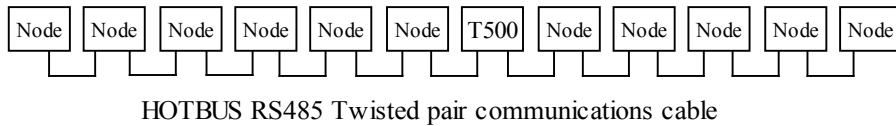

FIG.1 (This is equivalent to fig.2)

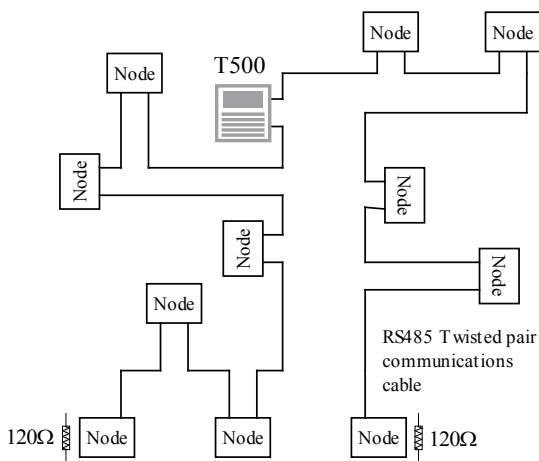

Fig 2
Correct

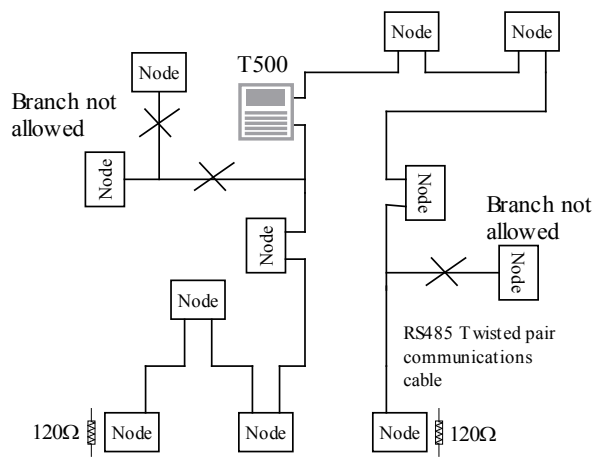

Fig 3
Wrong

Recommended External Power Supply Fusing

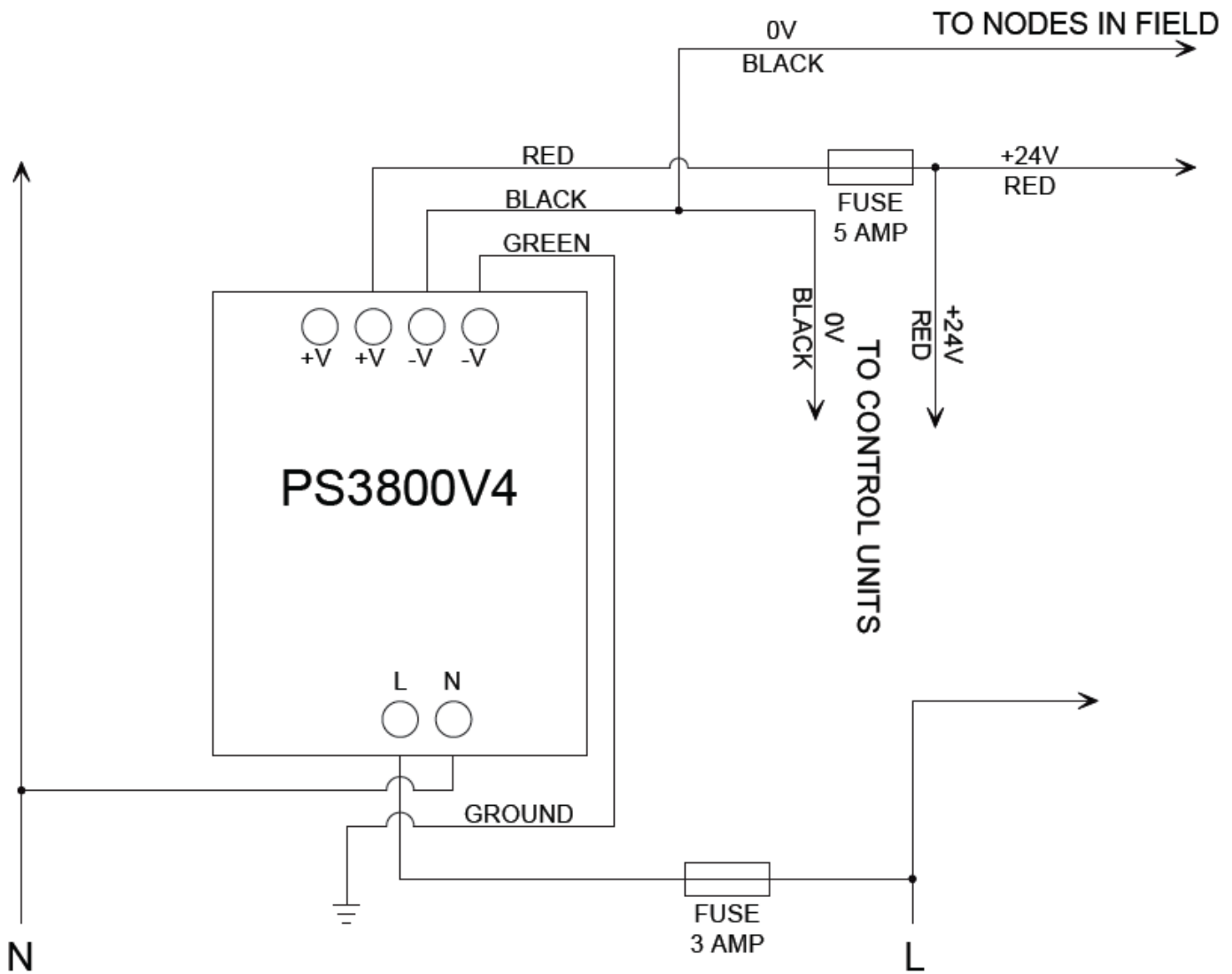
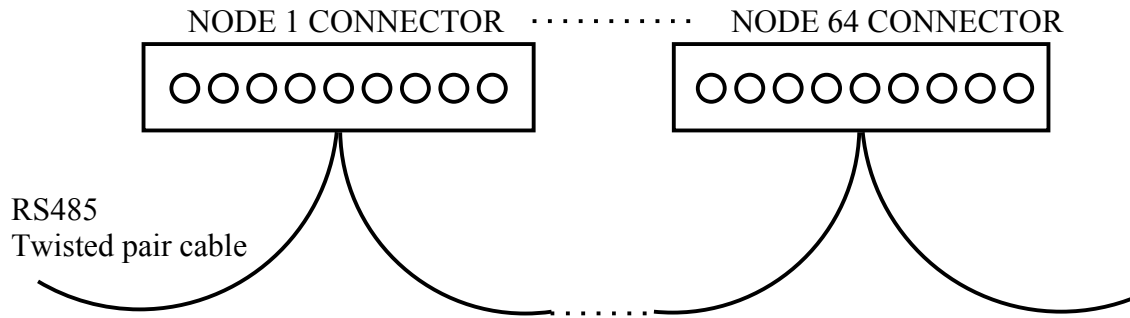
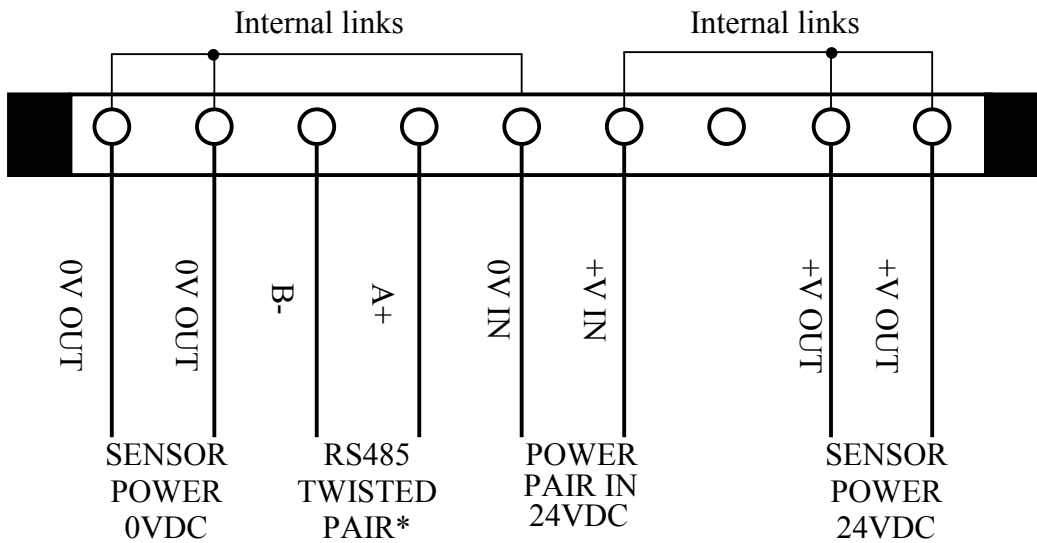

FIG 4



* Use Belden 9841 (or equivalent) RS485 communications cable



TN4 / TN4e CONNECTOR

FIG 5

HOTBUS-TN4 Sample Wiring Diagram

Notes

1. All shields should be insulated and should not be grounded to the enclosure or conduit. The shields should be continuous and should be connected to ground at one end of the network only.
2. All "S" Shield Terminals are internally connected inside the node and should not be used.
3. We recommend sensor cables be extended no more than 100 ft. Extending beyond that can affect the sensor readings.
4. Connect 120 Ohm termination resistors across the "A" and "B" terminals at each end of the network. There should only be two resistors per network.

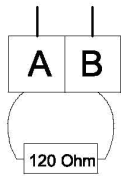

5. The dipswitch on each node should match the baudrate of the system.
 Setting 1 – T500 v 3.0.9 or earlier
 Setting 2 – T500 v 7.0.0 or later

Denotes core not connected and should be insulated

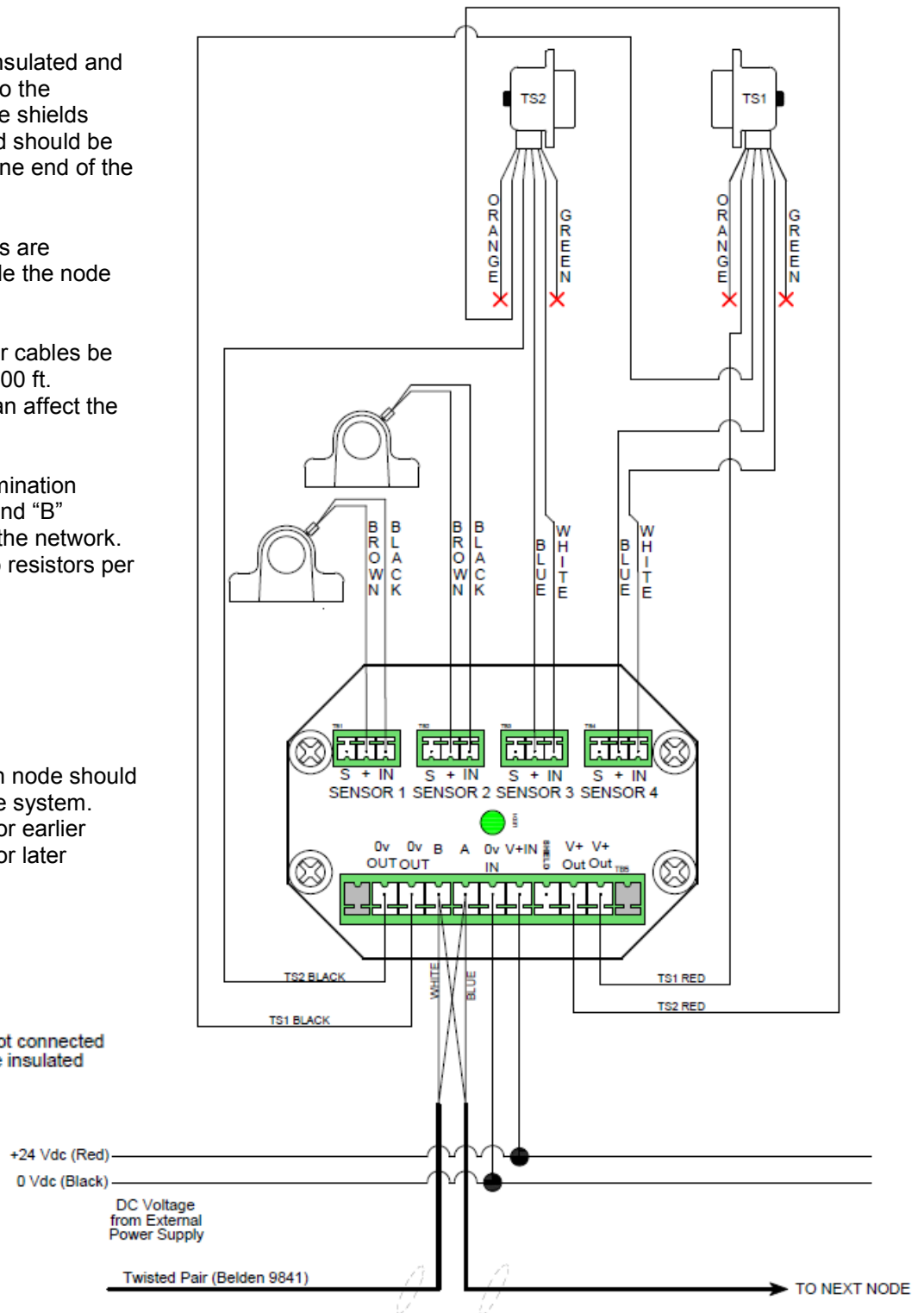

FIG 6

HOTBUS-SN2 Sample Wiring Diagram

Notes

1. All shields should be insulated and should not be grounded to the enclosure or conduit. The shields should be continuous and should be connected to ground at one end of the network only.

2. We recommend sensor cables be extended no more than 100 ft. Extending beyond that can affect the sensor readings.

3. Connect 120 Ohm termination resistors across the "A" and "B" terminals at each end of the network. There should only be two resistors per network.

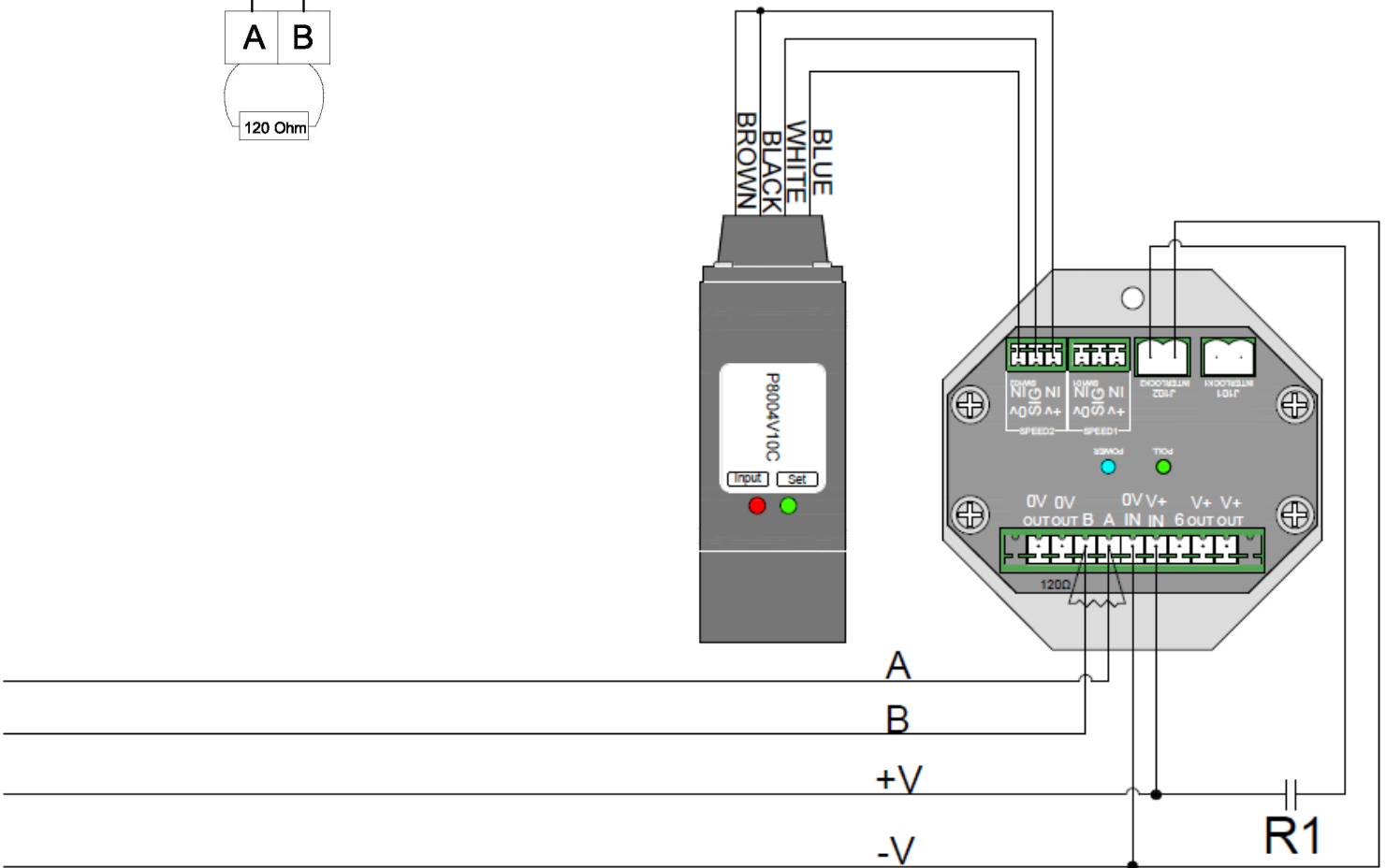
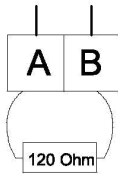
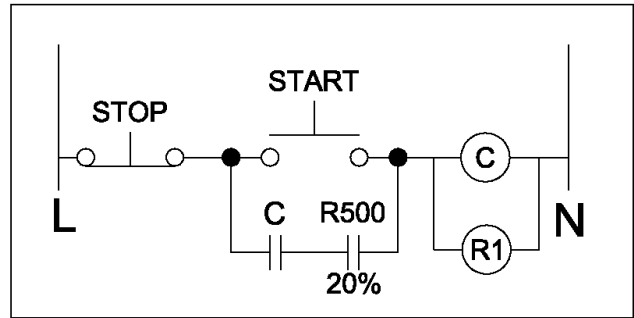

FIG 7

T500 Communications Error Messages Explained

Communications error C1 (SYNC error)

Error C1 occurs when the T500 has received information from a node but the information does not begin with the expected synchronization character.

Communications error C2 (HDB2 error)

Error C2 occurs when the T500 has received information from a node, the synchronization character is correct but the first part of the data header information is incorrect.

Communications error C3 (HDB1 error)

Error C3 occurs when the T500 has received information from a node the synchronization character is correct, the first part of the data header is correct but the second part of the data header information is incorrect.

Communications error C4 (CRC error)

Error C4 occurs when the T500 has received information from a node, the information structure is correct but a data corruption has been detected in the information.

Possible cause: C1 to C4

- > Poor cable connection
- > Connection A+ and B- crossed at the T500 or at the node if just 1 node shows the fault
- > Shield connection incorrectly terminated or terminated at both ends of the cable rather than just at the T500
- > No or incorrectly installed termination resistors
- > Possible interference from other electrical equipment or 'Walkie Talkie' type devices

Troubleshooting C1-C4 errors (typically effects multiple nodes):

- Check for nodes with abnormally flashing LEDs. The LED should flash whenever the node responds to the T500 (approximately 1 to 8 seconds). Try removing nodes which are flashing abnormally to see if the rest of the network begins working again.
- Check if the shield is touching conduit or any sensor wires in any of the junction boxes. Multiple ground connections on the shield can cause noise on the communications wires. Make sure that the shield only has a path to ground at the T500 (you should read an open circuit with your multi-meter between shield and ground when the Hotbus terminal is unplugged from the T500 and a short circuit when it is plugged in).
- Check that the A & B wires are terminated at every node and at the T500. Verify that the A & B wires are not disconnected or reversed anywhere.
- Note the time of day and what equipment is running if the communication errors are intermittent. This may help determine the cause. Ensure that the communications cable is only run in conduit with low voltage wires.
- Verify that the termination resistors are installed at both ends of the network.
- Check for water in the node enclosures.

Communications error C5 (Lost communications error)

Error C5 occurs when the T500 has not received information from a programmed node even after trying 6 times.

Possible cause: C5

- > Poor/no cable connection
- > Connection A+ and B- crossed at the T500 or at the node if just 1 node shows the fault
- > Shield connection shorted to A+ or B-
- > Faulty node
- > No power to the node
- > Wire broken at the node
- > Node connector missing or unplugged
- > Incorrect node programming in the T500 (wrong node address used)

Troubleshooting C5 Errors (Can effect 1 or more nodes)

- Verify that all node and T500 terminals are plugged in all the way.
- Are the nodes receiving 24Vdc power?
- Make sure that all A & B communications wires are landed properly.
- Try to replace one of the nodes with a known working node, program the new address into the T500 and see if it communicates.
- Verify that the entire network is less than 3,000 ft. If it extends farther, repeaters will be needed.
- Check that the node address in the T500 matches the address printed on the node.
- Check for water in the node enclosures.

Communications errors C1 to C5 are helpful in diagnosing simple wiring errors. If having checked through and corrected any of the possible causes the fault persists, please contact 4B for more information.

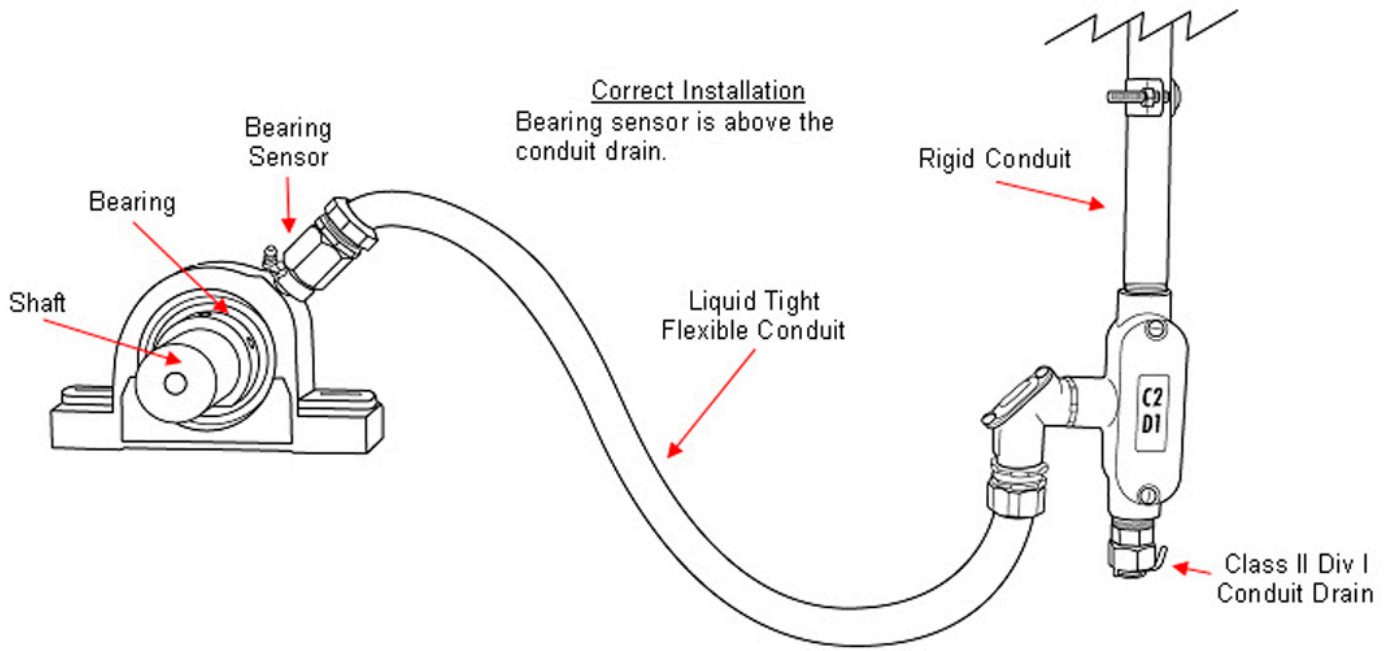

FIG 8

Hotbus Sensor Name Chart

Network 1 (Example shown with 2 bearing sensors and 2 belt alignment sensors per node)

ID	Machine Name	Machine Type	Sensor Type	Node Physical Order	Node Address	Sensor #	Sensor Name 20 Characters Maximum (including spaces)	Trip Point above Ambient
A			Bearing Sensor			1	XXXXXXXXXXXXXXXXXXXXXX	30
			Bearing Sensor			2		30
			TouchSwitch			3		N/A
			TouchSwitch			4		N/A
			Bearing Sensor			5		30
			Bearing sensor			6		30
			TouchSwitch			7		N/A
			TouchSwitch			8		N/A
B			Bearing Sensor			9		30
			Bearing Sensor			10		30
			TouchSwitch			11		N/A
			TouchSwitch			12		N/A
			Bearing Sensor			13		30
			Bearing sensor			14		30
			TouchSwitch			15		N/A
			TouchSwitch			16		N/A
C			Bearing Sensor			17		30
			Bearing Sensor			18		30
			TouchSwitch			19		N/A
			TouchSwitch			20		N/A
			Bearing Sensor			21		30
			Bearing sensor			22		30
			TouchSwitch			23		N/A
			TouchSwitch			24		N/A
D			Bearing Sensor			25		30
			Bearing Sensor			26		30
			TouchSwitch			27		N/A
			TouchSwitch			28		N/A
			Bearing Sensor			29		30
			Bearing sensor			30		30
			TouchSwitch			31		N/A
			TouchSwitch			32		N/A
E			Bearing Sensor			33		30
			Bearing Sensor			34		30
			TouchSwitch			35		N/A
			TouchSwitch			36		N/A
			Bearing Sensor			37		30
			Bearing sensor			38		30
			TouchSwitch			39		N/A
			TouchSwitch			40		N/A