

Watchdog™ Super Elite

BUCKET ELEVATOR & BELT CONVEYOR

HAZARD MONITORING SYSTEM



INSTALLATION INSTRUCTIONS

OPERATION MANUAL

Part No.'s - WDC4V4C, WDC4V46C
Hardware Version R4 - Software Version 4.7.X

www.go4b.com/usa

TABLE OF CONTENTS

1. CUSTOMER SAFETY RESPONSIBILITIES	Page 6 - 7
2. PRODUCT OVERVIEW	Page 8
3. SPECIFICATIONS	Page 8
4. FEATURES	Page 9 - 10
5. DIMENSIONS	Page 11
6. INSTALLATION	Page 11
7. SENSOR PLACEMENT DIAGRAMS	Page 12
8. ELECTRICAL CONNECTION	Page 13 -14
9. WIRING DIAGRAMS	Page 15 - 25
9.1 Wiring Block Diagram for Bucket Elevator & Belt Conveyor	Page 15
9.2 Control Wiring Diagram (120 - 240 VAC)	Page 16
9.3 Control Wiring Diagram (24 VDC)	Page 17
9.4 Control Wiring Diagram for Multiple Units	Page 18 - 19
9.5 Select New Profile	Page 20
9.6 WDC3 to WDC4 Sensor Wiring Diagram	Page 21
9.7 Sensor Wiring Diagram Profile with Touchswitches	Page 22
9.8 Sensor Wiring Diagram Profile with Rub Blocks	Page 23
9.9 Sensor Wiring Diagram Profile with Motion Alignment Sensors	Page 24
9.10 Sensor Wiring Diagram Profile with Knee or Idler Pulleys	Page 25
10. WATCHDOG MAIN LCD SCREEN	Page 26 - 31
10.1 Start Up Screen (Initial Power Up)	Page 26
10.2 Main LCD Screen & Sensor LEDs	Page 27
10.3 Alarm Log Button	Page 28
10.4 Menu Button	Page 28
10.5 System Info Button	Page 28
10.6 Speed Info (1 of 7)	Page 28
10.7 Head Align Info (2 of 7)	Page 29
10.8 Tail Align Info (3 of 7)	Page 29
10.9 HBS Info (4 of 7)	Page 30
10.10 Aux Sensor Info (5 of 7)	Page 30
10.11 System Info (6 of 7)	Page 31
10.12 Network Info (7 of 7)	Page 31
11. VIEW SETTINGS	Page 32
12. SETUP	Page 33
12.1 Password	Page 33
13. RESET ENGINEERING PASSWORD	Page 34
14. PROFILE	Page 35 - 52
14.1 Edit Selected Profile	Page 35

TABLE OF CONTENTS



14.2 Calibrate System	Page 36
14.2.A - System Recalibration	Page 36
14.2.B - Incorrect Calibration	Page 36
14.2.C - Start Up Timer	Page 36
14.3 Full System Setup	Page 37
14.4 System	Page 37
14.4.A - Temperature Units	Page 37
14.4.B - Pre Abs Alarm	Page 37
14.4.C - Negative Differential Alarm	Page 37
14.4.D - Rate of Rise Start Up Delay	Page 37
14.4.E - Expansion 1 - Optional Expansion Board	Page 38
14.4.F - Expansion 2 - Optional Expansion Board	Page 38
14.5 Speed	Page 39
14.5.A -Speed Monitoring	Page 39
14.5.B - Scaling Units	Page 39
14.5.C - Scaling Factor	Page 39
14.5.D - Speed Detection Source	Page 39 - 41
14.5.E - Acceleration Monitoring Level	Page 41
14.5.F - Number of Starts / Minute	Page 42
14.5.G - Start Up Delay	Page 42
14.5.H - Underspeed Alarm	Page 42
14.5.I - Severe Underspeed	Page 42
14.5.J - Underspeed Alarm Delay	Page 42
14.5.K - Underspeed Stop Delay	Page 42
14.5.L - Overspeed	Page 43
14.5.M - Severe Overspeed	Page 43
14.5.N - Overspeed Alarm Delay	Page 43
14.5.O - Overspeed Stop Delay	Page 43
14.6 Alignment (Head)	Page 43
14.6.A - Head Sensor Pair	Page 44
14.6.B - Head Trigger Alarm	Page 44
14.6.C - Absolute Alarm	Page 44
14.6.D - Relative Alarm Source	Page 44
14.6.E - Relative Alarm	Page 44
14.6.F - Head: Rate of Rise	Page 44
14.6.G - Head Alarm Delay	Page 45
14.6.H - Head Stop Delay	Page 45
14.7 Alignment (Tail)	Page 46

TABLE OF CONTENTS

14.7.A - Tail Sensor Pair	Page 46
14.7.B - Tail Trigger Alarm	Page 36
14.7.C - Absolute Alarm	Page 36
14.7.D - Relative Alarm Source	Page 36
14.7.E - Relative Alarm	Page 46
14.7.F - Tail: Rate of Rise	Page 47
14.7.G - Tail Alarm Delay	Page 47
14.7.H - Tail Stop Delay	Page 47
14.8 Temperature	Page 48
14.8.A - HBS	Page 48
14.8.B - HBS: Absolute Alarm	Page 48
14.8.C - HBS: Relative Alarm Source	Page 48
14.8.D - HBS: Relative Alarm	Page 48
14.8.E - HBS: Rate of Rise	Page 49
14.8.F - HBS: Alarm Delay	Page 49
14.8.G - HBS: Stop Delay	Page 49
14.8.H - AMB	Page 49
14.8.I - AMB: Absolute Alarm	Page 49
14.8.J - AMB: Rate of Rise	Page 49
14.8.K - AMB: Alarm Delay	Page 50
14.8.L - AMB: Stop Delay	Page 50
14.9 Auxiliary	Page 50
14.9.A - Plug Enabled	Page 50
14.9.B - Plug Trigger Alarm When	Page 50
14.9.C - Plug Alarm Delay	Page 50
14.9.D - Plug Stop Delay	Page 51
14.9.E - Pulley Enabled	Page 51
14.9.F - Pulley Trigger Alarm When	Page 51
14.9.G - Pulley Alarm Delay	Page 51
14.9.H - Pulley Stop Delay	Page 51
14.10 Restore Defaults	Page 52
14.11 Select New Profile	Page 52
15. TEST	Page 53 - 54
15.1 Alarm Relay	Page 53
15.2 Alignment	Page 53
15.3 Over Speed	Page 53
15.4 Under Speed	Page 54
15.5 Hot Bearing Sensor	Page 54

TABLE OF CONTENTS

16. FACTORY SETTINGS	Page 54 - 55
16.1 Edit Selected Profile	Page 55
16.2 Restore Defaults	Page 55
16.3 Select New Profile	Page 55
17. SD CARD	Page 56
18. TIME & DATE	Page 57
19. CHANGE PASSWORD	Page 57
20. NETWORK	Page 58
21. TROUBLESHOOTING GUIDE	Page 59
22. APPENDIX A - MENU TREE	Page 60
23. APPENDIX B - FACTORY DEFAULT SETTINGS	Page 61 - 62
24. APPENDIX C - WDC4 CONFIGURATOR SOFTWARE	Page 63
25. APPENDIX D - WDC4 SOFTWARE UPDATE	Page 64
26. PRODUCT WARRANTY	Page 65





 **WARNING**

Rotating parts can crush, cut and entangle.

Do NOT operate with guard removed.

Lockout power before removing guard or servicing.

 **DANGER**



Exposed buckets and moving parts will cause severe injury or death.

Lockout power before removing cover or inspection door.

 **DANGER**



Exposed moving parts will cause severe injury or death.

Lockout power before removing cover or inspection door.

Dear 4B Customer:

Congratulations on your purchase. 4B appreciates your business and is pleased you have chosen our products to meet your needs.

Please read in its entirety and understand the literature accompanying the product before you place the product into service. Please read the safety precautions carefully before operating the product. With each product you purchase from 4B, there are some basic but important safety considerations you must follow to be sure your purchase is permitted to perform its design function and operate properly and safely, giving you many years of reliable service. Please read and understand the Customer Safety Responsibilities listed below. Failure to follow this safety directive and the Operation Manuals and other material furnished or referenced, may result in serious injury or death.

SAFETY NOTICE TO OUR CUSTOMERS

- A. In order to maximize efficiency and safety, selecting the right equipment for each operation is vital. The proper installation of the equipment, and regular maintenance and inspection is equally important in continuing the proper operation and safety of the product. The proper installation and maintenance of all our products is the responsibility of the user unless you have asked 4B to perform these tasks.
- B. All installation and wiring must be in accordance with Local and National Electrical Codes and other standards applicable to your industry. (Please see the article “Hazard Monitoring Equipment Selection, Installation and Maintenance” at www.go4b.com.) The installation of the wiring should be undertaken by an experienced and qualified professional electrician. Failure to correctly wire any product and/or machinery can result in the product or machine failing to operate as intended, and can defeat its design function.
- C. Periodic inspection by a qualified person will help assure your 4B product is performing properly. 4B recommends a documented inspection at least annually and more frequently under high use conditions.
- D. Please see the last page of this manual for all warranty information regarding this product.

CUSTOMER SAFETY RESPONSIBILITIES

1. READ ALL LITERATURE PROVIDED WITH YOUR PRODUCT

Please read all user, instruction and safety manuals to ensure that you understand your product operation and are able to safely and effectively use this product.

2. YOU BEST UNDERSTAND YOUR NEEDS

Every customer and operation is unique, and only you best know the specific needs and capabilities of your operation. Please call the 24-hour hotline at 309-698-5611 for assistance with any questions about the performance of products purchased from 4B. 4B is happy to discuss product performance with you at any time.

3. SELECT A QUALIFIED AND COMPETENT INSTALLER

Correct installation of the product is important for safety and performance. If you have not asked 4B to perform the installation of the unit on your behalf, it is critical for the safety of your operation and those who may perform work on your operation that you select a qualified and competent electrical installer to undertake the installation. The product must be installed properly to perform its designed functions. The installer should be qualified, trained, and competent to perform the installation in accordance with Local and National Electrical Codes, all relevant OSHA Regulations, as well as any of your own standards and preventive maintenance requirements, and other product installation information supplied with the product. You should be prepared to provide the installer with all necessary installation information to assist in the installation.

4. ESTABLISH AND FOLLOW A REGULAR MAINTENANCE AND INSPECTION SCHEDULE FOR YOUR 4B PRODUCTS

You should develop a proper maintenance and inspection program to confirm that your system is in good working order at all times. You will be in the best position to determine the appropriate frequency for inspection. Many different factors known to the user will assist you in deciding the frequency of inspection. These factors may include but are not limited to weather conditions; construction work at the facility; hours of operation; animal or insect infestation; and the real-world experience of knowing how your employees perform their jobs. The personnel or person you select to install, operate, maintain, inspect or perform any work whatsoever, should be trained and qualified to perform these important functions. Complete and accurate records of the maintenance and inspection process should be created and retained by you at all times.

5. RETAIN AND REFER TO THE OPERATION MANUAL FOR 4B'S SUGGESTED MAINTENANCE AND INSPECTION RECOMMENDATIONS

As all operations are different, please understand that your specific operation may require additional adjustments in the maintenance and inspection process essential to permit the monitoring device to perform its intended function. Retain the Operation Manual and other important maintenance and service documents provided by 4B and have them readily available for people servicing your 4B equipment. Should you have any questions, please call the free 24-hour hotline number (309-698-5611).

6. SERVICE REQUEST

If you have questions or comments about the operation of your unit or require the unit to be serviced please contact the 4B location who supplied the product or send your request via fax (309-698-5615) or call us via our 24-hour hotline number in the USA (309-698-5611). Please have available product part numbers, serial numbers, and approximate date of installation. In order to assist you, after the product has been placed into service, complete the online product registration section which is accessed via our website www.go4b.com/usa.

WARNING

- Rotating machinery can cause serious injury or death
- Always lockout and tagout the machine prior to installation

2. PRODUCT OVERVIEW

The Watchdog Super Elite (WDC4) is a user-programmable, microprocessor controlled bucket elevator and belt conveyor monitor. The control unit accepts signals from sensors for belt misalignment, belt speed & slip, continuous bearing temperature, pulley misalignment and plug condition monitoring. The unit is able to sound an alarm and provide shutdown control of the elevator or conveyor, and feeding system, when a potentially hazardous condition is detected.

Microprocessors and electronics are housed in a self-contained wall mounted control unit. An LCD screen on the front of the unit displays system status. Calibration and set-up parameters are accessed via a password and front panel touch buttons.

The Watchdog Super Elite can also integrate into [HazardMon.com®](https://www.hazardmon.com), which is a secure cloud based hazard monitoring solution providing status notifications and data logging for bucket elevators and conveyors. Live system status, graphs and historical data can be viewed on any web-enabled device (smartphone, tablet PC, desktop or laptop computer). Emails can be sent to notify users whenever a change in the system's health is detected. An automated maintenance feature allows site operators to verify that all sensors on the system are operational and working correctly.

3. SPECIFICATIONS

Supply Voltage -	120 to 240 VAC or 24 VDC (WDC4V46C) 24 VDC (WDC4V4C)
Power Consumption (Max.) -	12 Watts
Power Terminals -	14 AWG / 4 mm ²
Signal Terminals -	16 AWG / 2.5 mm ²
Alarm Relay Contacts -	1 Pole Normally Open - 8A @ 250 VAC Voltage Free Changeover
Stop Relay Contacts -	1 Pole Normally Open - 8A @ 250 VAC Voltage Free Changeover
Sensor Supply -	24 VDC @ 800 mA (Across F1, F2 and F3)
Sensor Inputs -	15 (Expandable to 27 with Auxiliary Boards)
Interlock Input -	24 VDC or 120 to 240 VAC
Dimensions (H x W x D) -	11-3/4 x 9-1/2 x 5-1/4 (inches) / 298 x 241 x 133 (mm)
Fixing Centers (H x W) -	10-7/8 x 6 (inches) / 276 x 152 (mm)
Cable Entry -	2 Holes 1-1/8 in. Diameter (28 mm)
Weight -	3 lbs / 1.3 kg
Protection -	IP66
Approvals -	<ul style="list-style-type: none">• CSA Class II Div 2 Groups F & G (WDC4V46C)• CSA Class II Div 1 Groups E, F & G (WDC4V4C - When Powered with a Class 2 Power Supply)• ATEX & CE (Versions Available)
PLC Communications -	<ul style="list-style-type: none">• Modbus TCP/IP (Standard)• ControlLogix® (See ProSoft® Technical Note - Available Online)

4. FEATURES

BELT MISALIGNMENT DETECTION -

The Watchdog Super Elite offers greater flexibility for belt misalignment monitoring. The supported methods are:

METHOD	DESCRIPTION	APPLICATION
Contact	Force activated contact signal. When contact from the belt occurs an alarm is generated.	Standard method, most reliable for misalignment detection.
Pulse	Continuous pulses are generated by detecting a ferrous metal source (bolts, buckets, chain). Absence of pulses generates an alarm condition.	Used for applications requiring non-contact sensors.
Rub Block	Processes temperature information from brass blocks to detect belt misalignment. When the belt rubs against the brass block heat from friction is generated.	Alternative detection method, not recommended due to unreliability.

BELT SPEED / SLIP DETECTION -

The Watchdog Super Elite also offers greater flexibility for belt speed / slip monitoring. The supported methods are:

METHOD	DESCRIPTION	APPLICATION
Dedicated Speed	Shaft rotation speed measurement.	Standard method, most commonly used.
Highest Pulse Rate	Speed determined by the detection of ferrous metal (bolts, buckets, chain) passing by the alignment sensors.	Used for applications requiring non-contact belt alignment sensors.
Differential Speed	A combination of both methods listed above.	Used with variable speed drives (VSD).

HOT BEARING DETECTION -

The Watchdog Super Elite can monitor up to 8 NTC type temperature sensors (standard). This can be expanded to a total of 20 NTC sensors with optional auxiliary boards. The supported alarm methods are:

METHOD	DESCRIPTION	APPLICATION
Absolute Temperature (ABS)	An alarm is raised if the sensed temperature exceeds the pre-set trip point.	Simple bearing detection for over heating, most commonly used.
Relative Temperature (REL)	An alarm is raised if the difference between the sensed temperature and the selected relative or ambient source temperature is greater than the pre-set trip point.	Used in addition to the first method and provides much earlier fault detection. Especially useful in cold weather as it is no longer necessary to wait until the bearing gets to a very high temperature before a failure detected.
Rate of Rise (dR - delta R)	An alarm is detected if the bearing starts to heat up at a rate higher than the pre-set value in degrees per minute.	Used in addition to the two methods above, and provides for an alternative fault detection for a failing bearing.

AUXILIARY INPUTS -

The Watchdog Super Elite also has auxiliary inputs for pulley misalignment, plug condition or blocked chute monitoring. These offer additional protection and prevent unnecessary costly downtime.

SETTINGS BACKUP & TRANSFER -

The controller is equipped with an SD card slot, and supports the ability to save and restore the system settings from the memory card. This also allows system settings from one unit to be copied to another, which is especially useful to duplicate settings on multiple controllers at the same location.

WDC4 CONFIGURATOR SOFTWARE -

The Watchdog Super Elite can be programmed directly through the controller's LCD menu screen, or by using the WDC4 Configurator Software (Appendix C). The software tool makes programming the Watchdog easier by providing all the system settings for each profile menu into one screen. Once a profile setup file has been created, it can be saved to an SD card and then uploaded to the Watchdog. For remote sites, the file can be emailed to an on-site technician, who can upload the file.

EVENT & ALARM LOGGING -

The last 40 events and alarms are logged, and can be viewed directly from the Watchdog's main LCD screen. If an SD card is installed, all events and alarms (not just the last 40) are saved on the card. The file can be imported into a spread sheet program to create more detailed logging and trending reports.

HAZARDMON.COM CONNECTIVITY -

The Watchdog Super Elite has in-built network support for Hazardmon.com service connectivity. HazardMon is a secure cloud based hazard monitoring solution providing status notifications and data logging for bucket elevators and conveyors. Live system status, graphs and historical data can be viewed on any web-enabled device (smartphone, tablet PC, desktop or laptop computer). Emails can be sent to notify users whenever a change in the system's health is detected. An automated maintenance feature allows site operators to verify that all sensors on the system are operational and working correctly.

To review of all the available features, and to see how the systems works for yourself register for a free demo account at: www.hazardmon.com.

5. DIMENSIONS

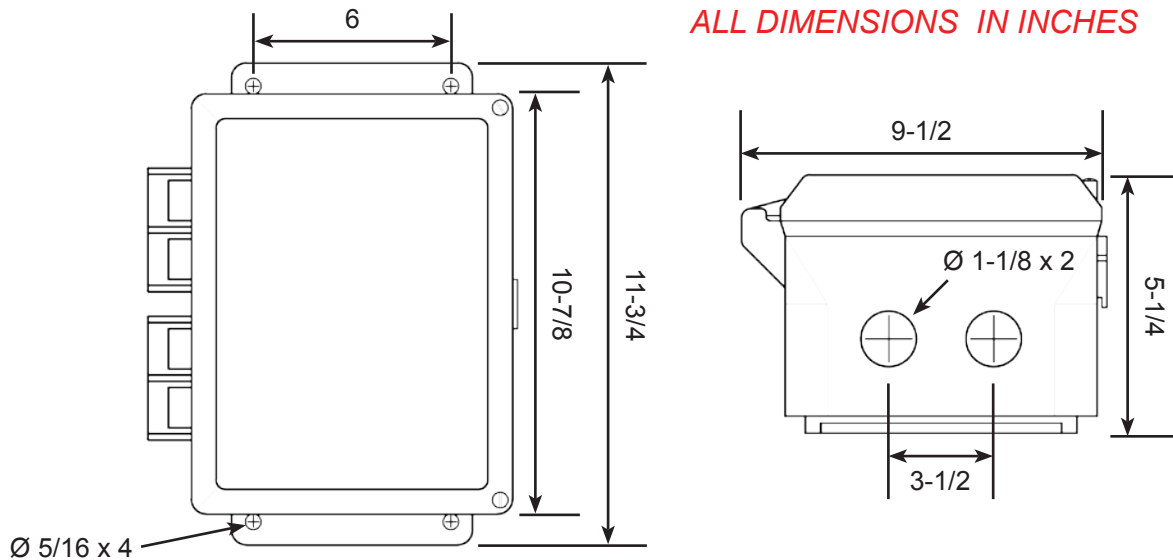

6. INSTALLATION

The WDC4 should be installed in a suitable control or switch room, and mounted at an eye level so that the warning lights and LED screen can be readily seen.

ENCLOSURE INSTALLATION -

1. Use the correct cable, glands and sealing arrangement in accordance with all installation codes.
2. Where other certified components are used as part of the assembly or installation procedure, the user must take in to account any limitations which might be listed on the relevant certificates.
3. The box is supplied with 2 x 1-1/8 inch (28.5 mm) pre drilled holes in the bottom face. All unused entry apertures must be sealed using component certified stopping plugs. The end user must install component or apparatus certified stopping plugs and cable glands/conduit in strict accordance with the manufacturer's instructions. In order to connect conduit to the control unit enclosure, use a CSA and/or UL certified Class II conduit hub (for example, a Myers™ hub) with a suitable bonding (grounding) connection that is rated for the installation environment.
4. The enclosure must not be modified in any way, as this will invalidate the certification.
5. All wiring must be carried out in accordance with relevant codes of practice and / or instructions.
6. The voltage, current and maximum power dissipation shown on the label must not be exceeded.
7. The wiring installation must extend to within 1 mm of the metal face of the terminal.
8. All leads must be insulated for the appropriate voltage.
9. Not more than 1 single or multiple strand cable is to be connected to any terminal unless multiple conductors have previously been joined in a suitable manner (e.g. boot lace ferrule) such that they present a single connection point to the terminal.
10. A flat-head or straight screwdriver of the correct size should be used to tighten terminals.

SENSOR INSTALLATION -

Follow the installation instructions for each sensor as provided in each individual product manual.



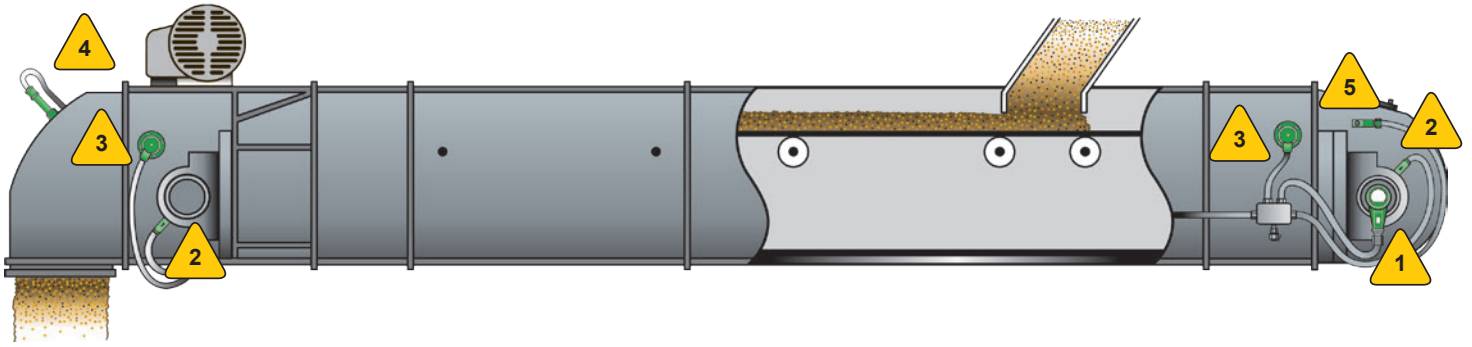

WARNING

The Control Unit is susceptible to static voltage, static handling precautions should be taken. Connection of a clean ground to terminal 16 is essential for optimum performance. Since the enclosure is a static hazard, it should only be cleaned with a damp cloth.

7. SENSOR PLACEMENT DIAGRAMS



TYPICAL SENSOR PLACEMENT FOR BUCKET ELEVATORS & ENCLOSED BELT CONVEYORS

-  **1** SPEED MONITORING
Qty. 1 - One sensor located on either side of the tail or boot shaft.
-  **2** BEARING TEMPERATURE
Qty. 4 - One sensor for the bearings at each end of the drive and tail or head and boot shafts.
-  **3** BELT MISALIGNMENT
Qty. 4 - Sensors work in pairs, one for each side of the belt on the drive and tail or head and boot sections.
-  **4** PLUG INDICATION
Qty. 1 - One sensor located near the top of the drive section or spouting by the discharge.
-  **5** TAIL PULLEY MISALIGNMENT (Enclosed Belt Conveyor)
Qty. 2 - One sensor located on each side of the housing on the conveyor tail section.

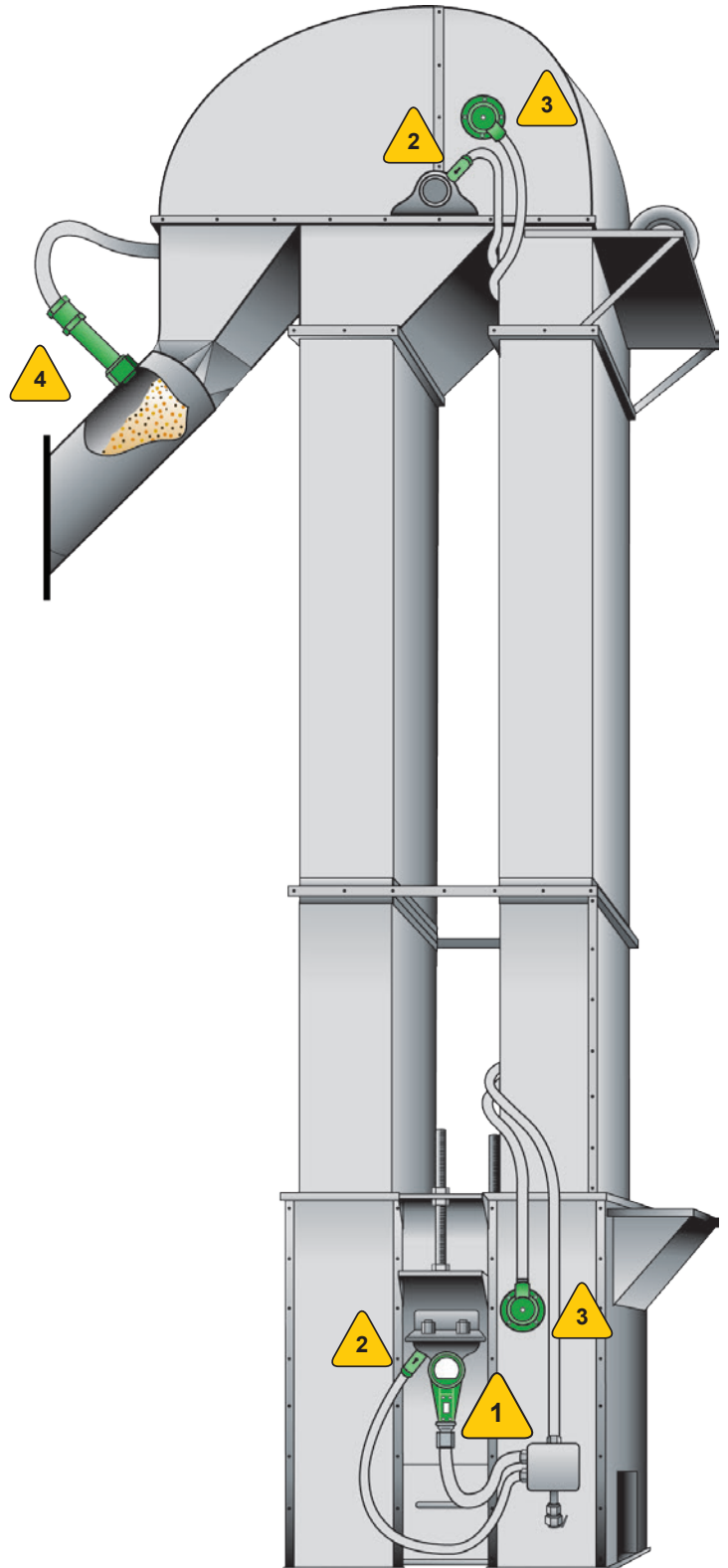

8. ELECTRICAL CONNECTION

All wiring must be in accordance with local and national electrical codes and should be undertaken by an experienced and qualified electrician.

Always use dust/liquid tight flexible metal conduit with approved fittings to protect the sensor cables. Use rigid metal conduit to protect the cables from the sensors to the control unit. Conduit systems can channel water due to ingress and condensation directly to sensors and sensor connections which over time will adversely affect the performance of the system. As such, the installation of low point conduit drains is recommended for all sensors.

All electrical connections are made via 3 sets of terminals provided as shown in image 1.

FUSE RATINGS -

In order to maintain the product certification, all fuses **MUST** be replaced with equivalent fuses at the same rating. Failure to do so will invalidate the certification and any warranties which may exist.

Model WDC4V4C -

- F1, F2, F3, F5 200 mA maximum.
- F1 to F3 are used to limit the current available to the sensor inputs.
- F5 is used to limit the current available to the internal electronics.
- F6 is not used.

Model WDC4V46C -

- F1 to F3 2 amp maximum, used to limit the current available to the sensor inputs.
- F5 200 mA, used to limit the current available to the internal electronics.
- F6 2 amp maximum, used to protect the AC power supply.

NOTE

To calibrate speed and utilize the Watchdog's built-in alarm and shut-down capabilities, a motor interlock (run) signal is required. For typical motor interlock wiring examples, review the wiring diagrams for terminals 6 & 7.

NOTE

Recommended cable type is Belden 5508FE with 10 conductors each 22 AWG, shielded. Overall outer diameter is 0.23 inches. Belden 5508FE wire colors are used in all of the sensor wiring diagrams in section 9.

⚠ WARNING

The unit should ONLY be powered with either a main supply (WDC4V46C model) OR a 24 VDC (WDC4V4C and WDC4V46C models) NOT BOTH (see specifications).

FIELD WIRING CONNECTIONS

- 44 - 0 VDC
- 43 - Speed Sensor
- 42 - Pulley Sensor
- 41 - Plug Sensor
- 40 - Head Rub - Right
- 39 - Head Rub - Left
- 38 - Head Align - Right
- 37 - Head Align - Left
- 36 - 24 VDC (Fuse F1)
- 35 - 0 VDC
- 34 - Tail Rub - Right
- 33 - Tail Rub - Left
- 32 - Tail Align - Right
- 31 - Tail Align - Left
- 30 - 24 VDC (Fuse F2)
- 29 - 0 VDC
- 28 - Bearing Sensor 6
- 27 - Bearing Sensor 5
- 26 - Bearing Sensor 4
- 25 - Bearing Sensor 3
- 24 - Bearing Sensor 2
- 23 - Bearing Sensor 1
- 22 - Ambient Sensor 2
- 21 - Ambient Sensor 1
- 20 - 24 VDC (Fuse F3)

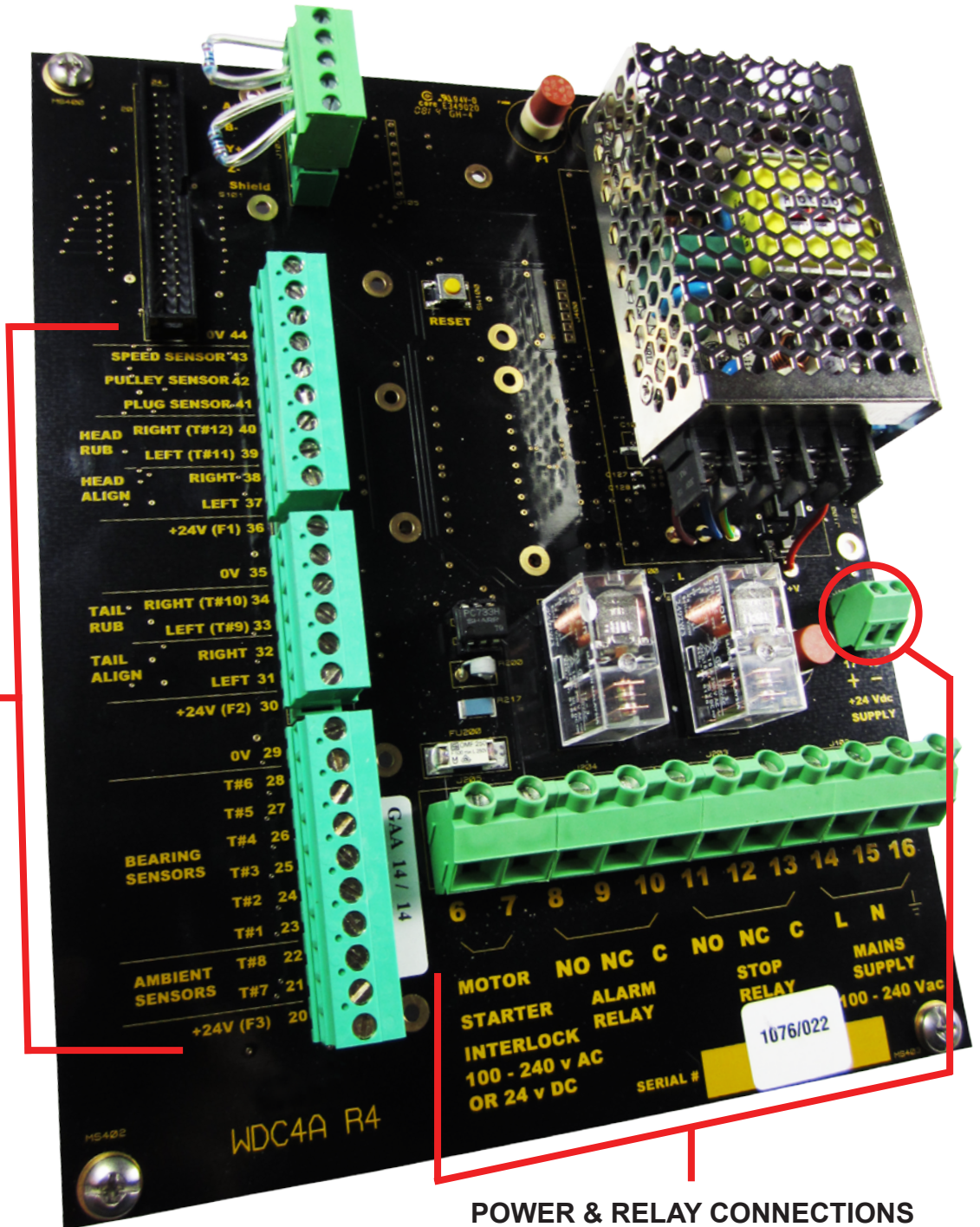

POWER & RELAY CONNECTIONS

- 06 - Motor Starter Interlock (-)
- 07 - Motor Starter Interlock (+)
- 08 - Alarm Relay Normally Open
- 09 - Alarm Relay Normally Closed
- 10 - Alarm Relay Common
- 11 - Stop Relay Normally Open
- 12 - Stop Relay Normally Closed
- 13 - Stop Relay Common
- 14 - 120 to 240 VAC Connection
- 15 - VAC Neutral Connection
- 16 - Ground or 0 Volt Connection
- 17 - 24 VDC Connection (+)
- 18 - 24 VDC Connection (-)

**Image 1 -
Inside View - Bottom Board
WDC4 Wiring Connections**

9. WIRING DIAGRAMS

9.1 WIRING BLOCK DIAGRAM FOR BUCKET ELEVATOR & BELT CONVEYOR -

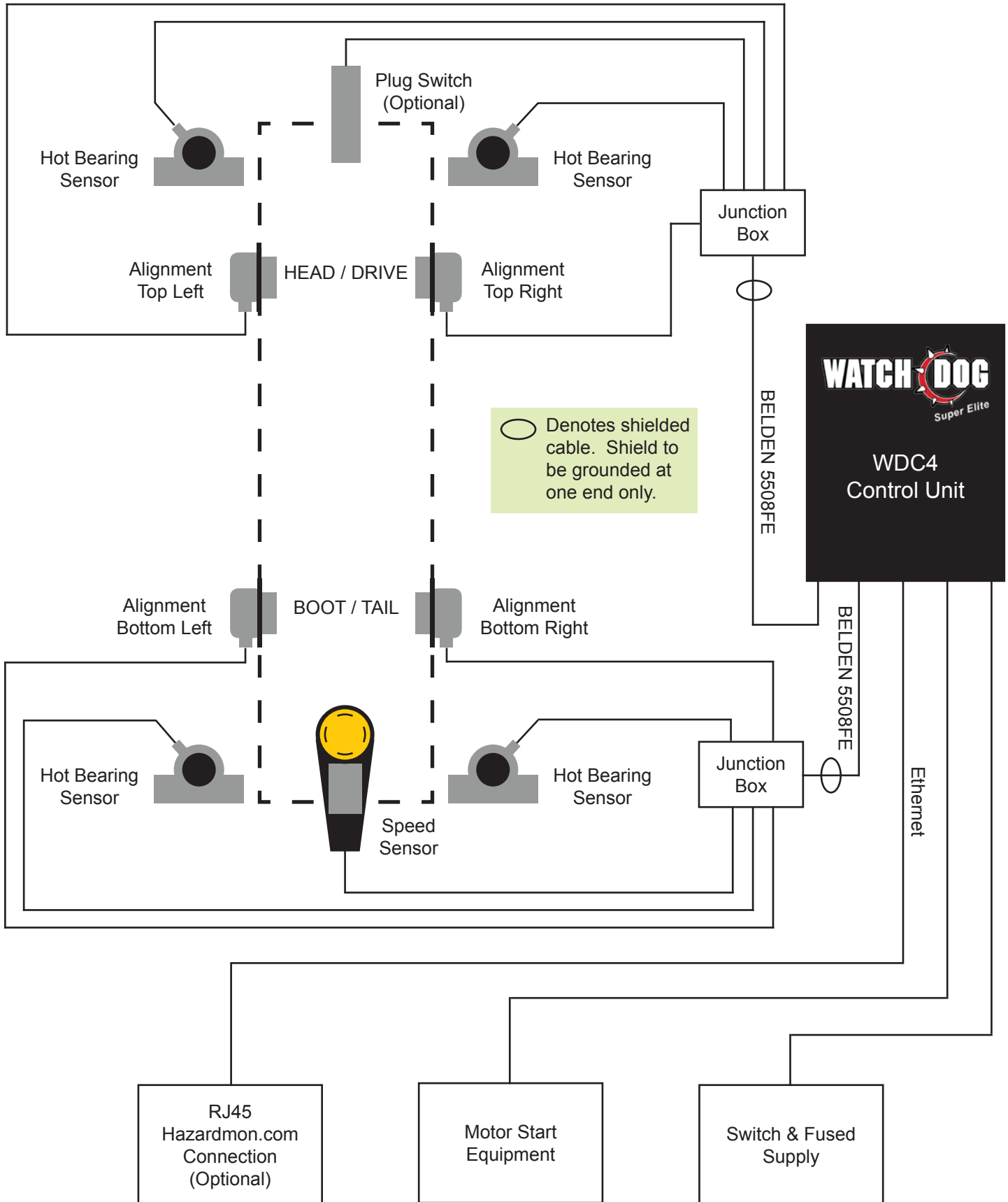

NOTE

- Metal conduit and liquid tight should be used to protect the cables from physical damage.
- Left and right are determined when facing the direction the bucket elevator discharges.

9.2 CONTROL WIRING DIAGRAM FOR WDC4V46C (120 to 240 VAC) -

Alarm and Stop Relays are Shown Energized in the Normal Running Condition

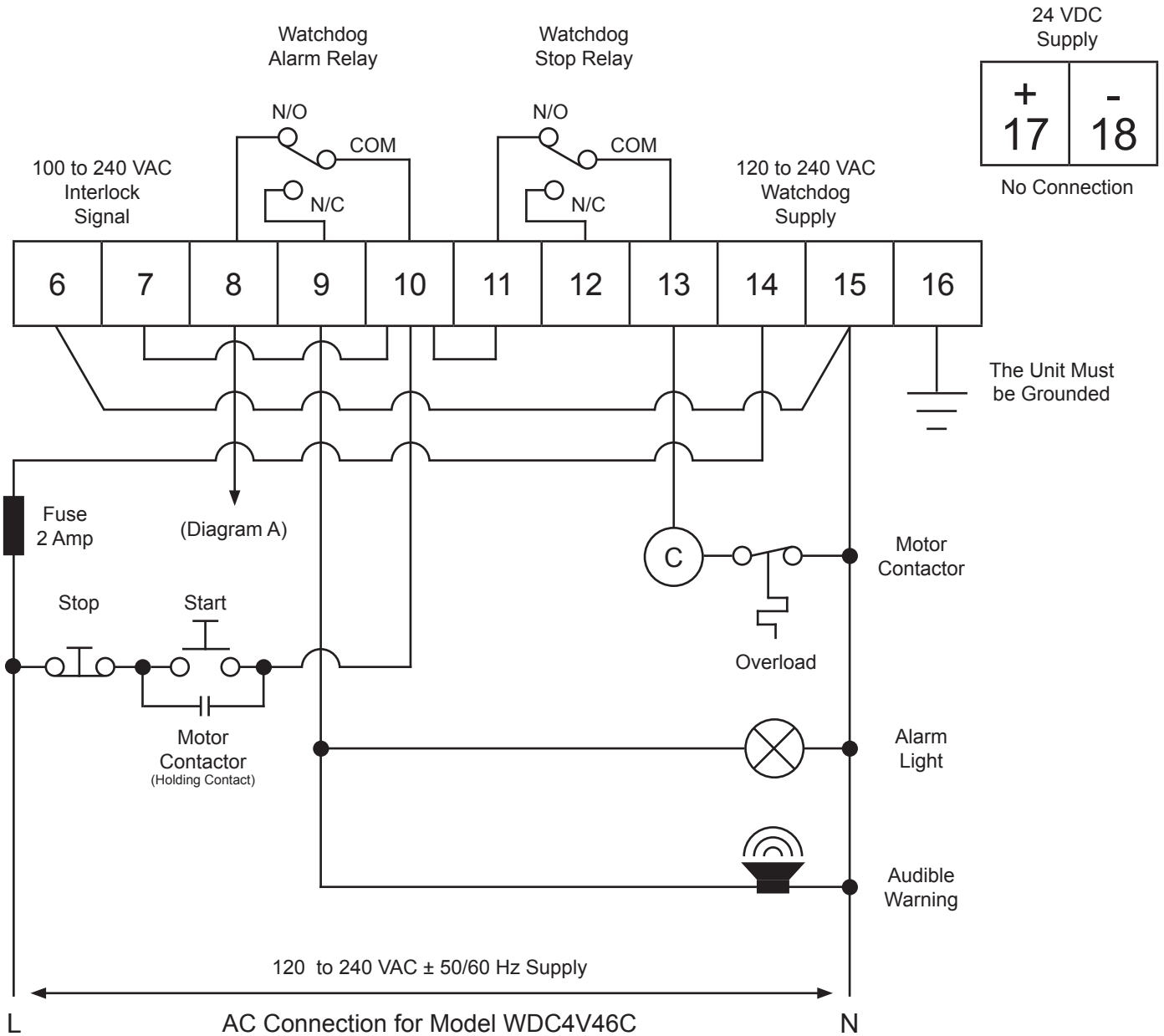
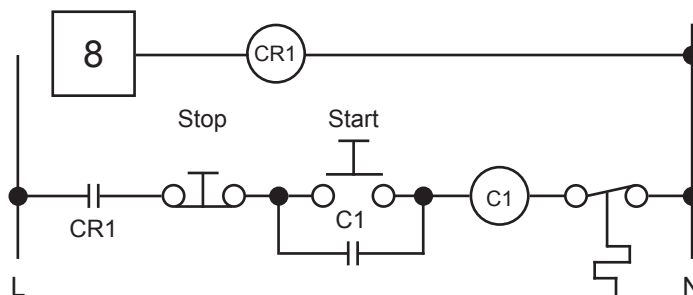

Diagram A: Automatic Shutdown Control Signal to Feed Equipment



NOTE

To calibrate speed and utilize the Watchdog's built-in alarm and shut-down capabilities, a motor interlock (run) signal is required. For typical motor interlock wiring examples, review the wiring diagrams for terminals 6 & 7.

9.3 CONTROL WIRING DIAGRAM FOR WDC4V4C (24 VDC) -

Alarm and Stop Relays are Shown Energized in the Normal Running Condition

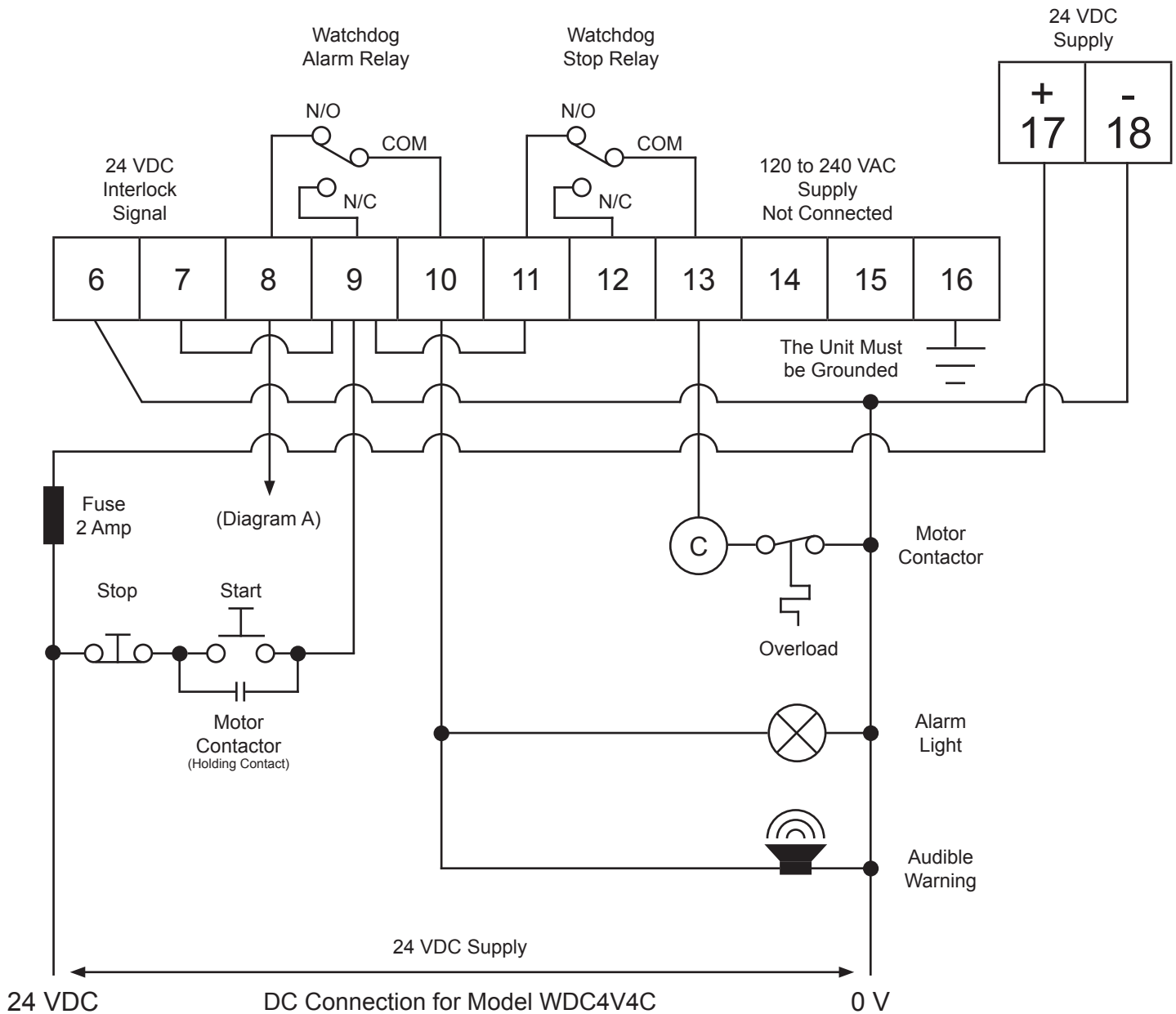
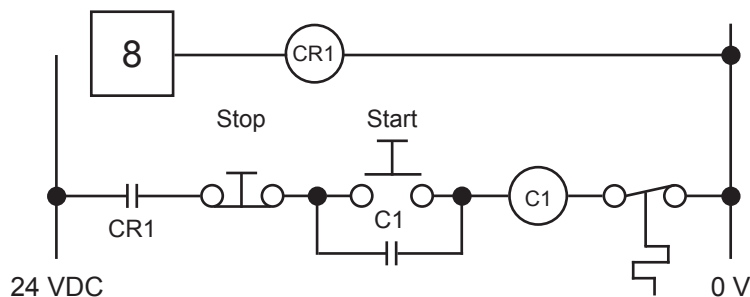

Diagram A: Automatic Shutdown Control Signal to Feed Equipment



NOTE

To calibrate speed and utilize the Watchdog's built-in alarm and shut-down capabilities, a motor interlock (run) signal is required. For typical motor interlock wiring examples, review the wiring diagrams for terminals 6 & 7.

9.4 CONTROL WIRING DIAGRAM FOR MULTIPLE UNITS WIRED TO THE SAME ALARM -

WATCHDOG CONTROL UNIT #1

Alarm and Stop Relays are Shown Energized in the Normal Running Condition

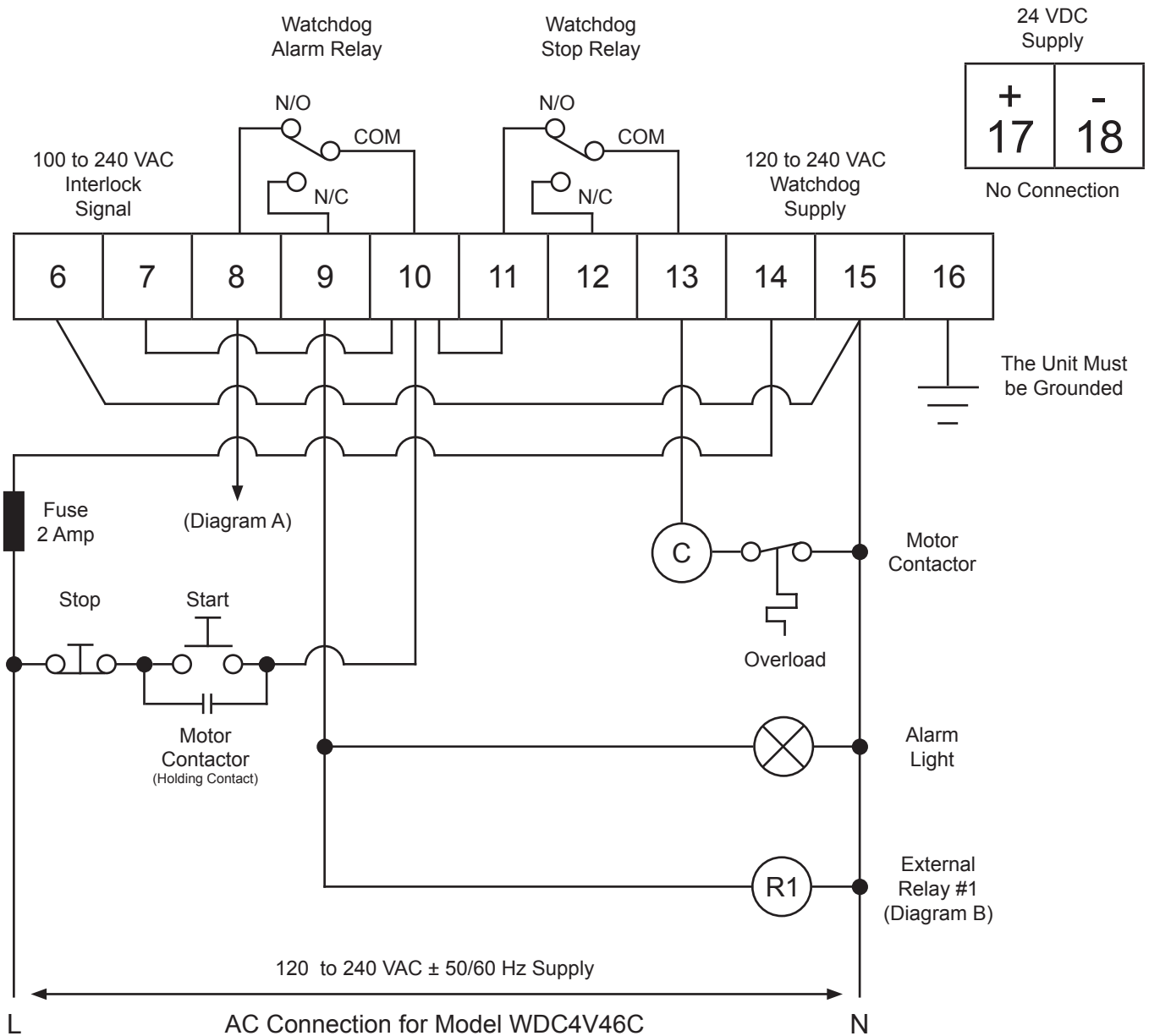
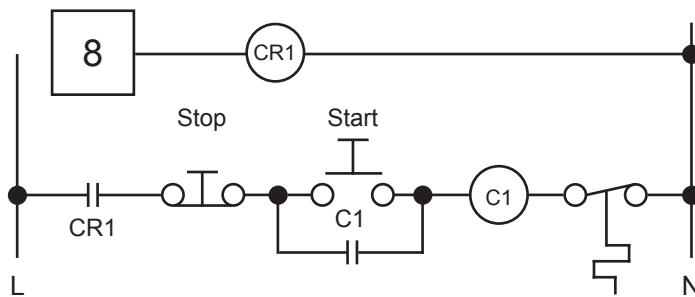

Diagram A: Automatic Shutdown Control Signal to Feed Equipment



NOTE

To calibrate speed and utilize the Watchdog's built-in alarm and shut-down capabilities, a motor interlock (run) signal is required. For typical motor interlock wiring examples, review the wiring diagrams for terminals 6 & 7.

WATCHDOG CONTROL UNIT #2

Alarm and Stop Relays are Shown Energized in the Normal Running Condition

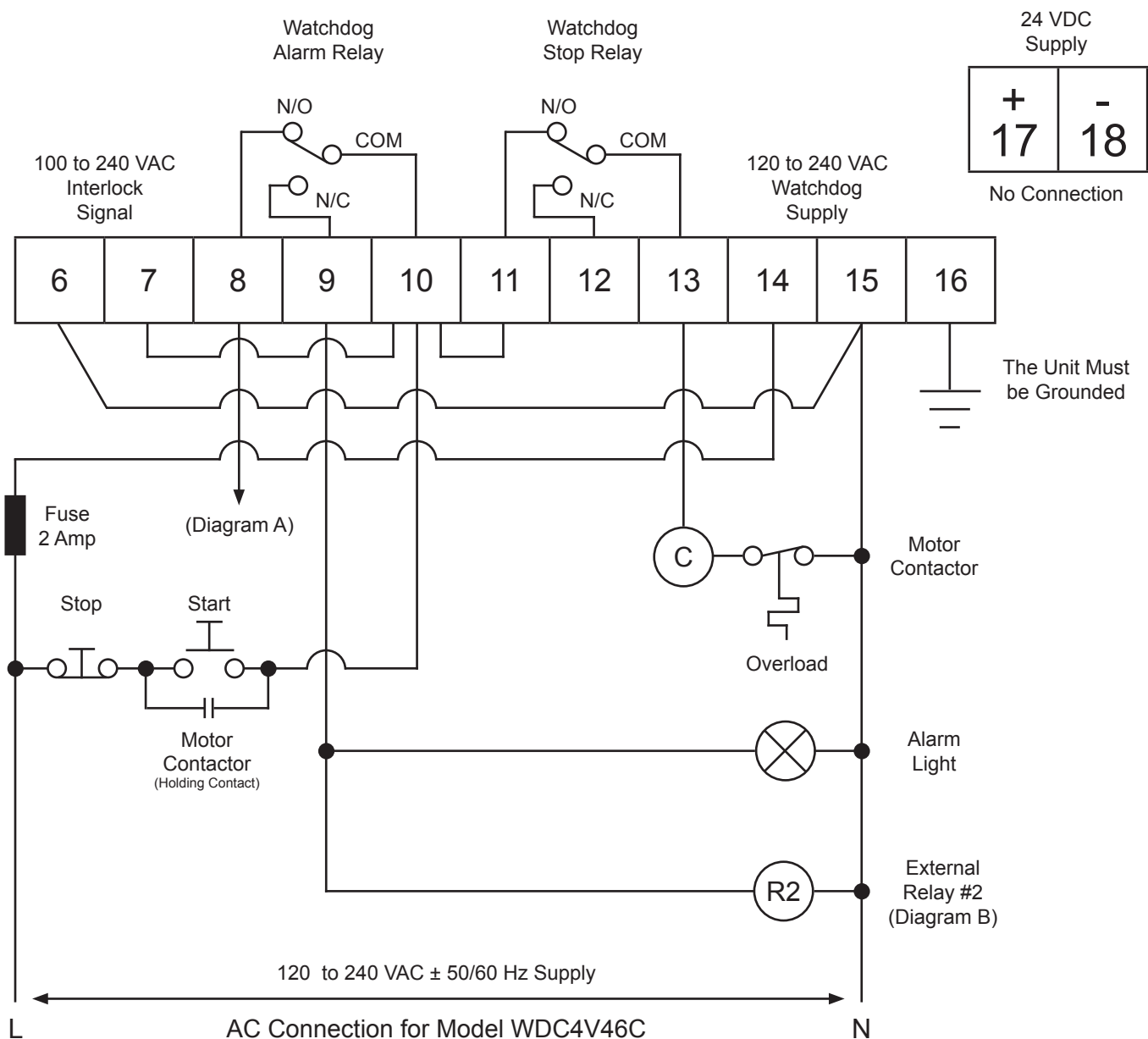
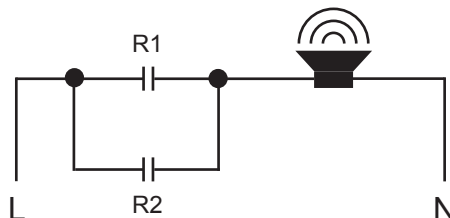

Diagram B: Multiple Watchdog Relays Linked to Audible Warning



NOTE

Recommended cable type is Belden 5508FE with 10 conductors each 22 AWG, shielded. Overall outer diameter is 0.23 inches. The shield is to be connected to ground at the Watchdog only.

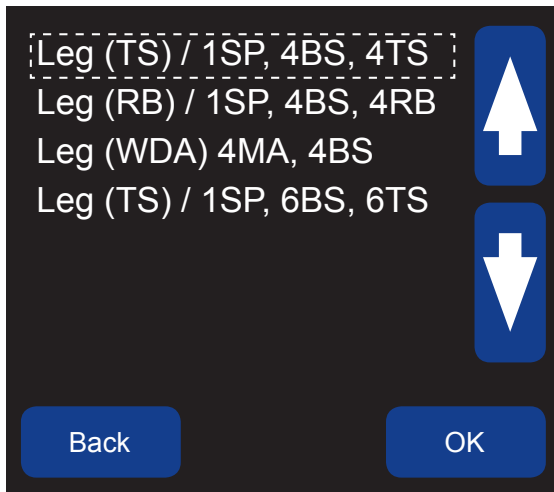

Image 2
Profile - Select New Profile

9.5 SELECT NEW PROFILE -

MENU > SETUP (PASSWORD) > PROFILE > SELECT NEW PROFILE

To help make the set up process easier for bucket elevator legs, four pre-set program profiles are available to choose from (Image 2). All four profiles are highlighted in RED at the top of each wiring diagram (9.7 - 9.10). Refer to section 14 for more information regarding sensor settings.

- | | |
|---|---|
| <ol style="list-style-type: none"> 1. LEG (TS) / 1 SP, 4BS, 4TS <ul style="list-style-type: none"> • 1 Speed Sensor • 4 Bearing Temperature Sensors • 4 Touchswitch Sensors (Alignment) 2. LEG (RB) / 1SP, 4BS, 4RB <ul style="list-style-type: none"> • 1 Speed Sensor • 4 Bearing Temperature Sensors • 4 Rub Block Sensors (Alignment) | <ol style="list-style-type: none"> 3. LEG (WDA) 4MA, 4BS <ul style="list-style-type: none"> • 4 Motion Alignment Sensors • 4 Bearing Temperature Sensors 4. LEG (TS) / 1SP, 6BS, 6TS <ul style="list-style-type: none"> • 1 Speed Sensor • 6 Bearing Temperature Sensors • 6 Touchswitch Sensors (Alignment) |
|---|---|

NOTE

All pre-set program profiles default to the factory settings. To modify settings from the factory defaults, go to the EDIT SELECTED PROFILE menu.

Wiring diagrams for the four pre-programmed profiles are shown in sections 9.6 - 9.9. More wiring diagrams are available online, please refer to the WATCHDOG SUPER ELITE SENSOR WIRING DIAGRAMS manual that can be found at www.go4b.com/usa. This online manual will continue to be updated as new wiring diagrams are completed and added.

9.6 WDC3 (RETIRED MODEL) TO WDC4 SENSOR WIRING DIAGRAM

MENU > SETUP (PASSWORD) > PROFILE > SELECT NEW PROFILE > LEG (WDA) 4MA, 4BS

NOTE

Wiring diagram 9.5 is for end users upgrading their WDC3 Watchdog to the WDC4 Watchdog Super Elite. This basic diagram provides a quick terminal reference between the two models.

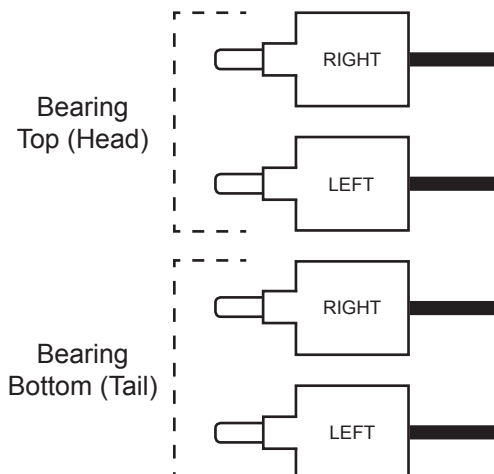
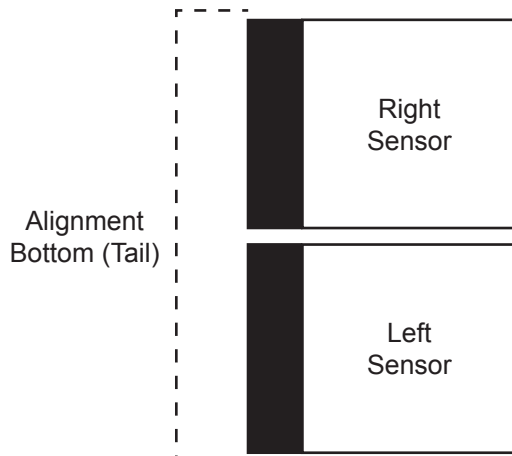
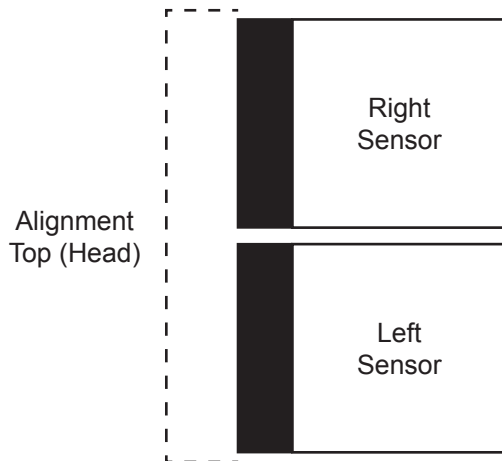

WDC3	WDC4	WDC4 Terminal
1	44	0 VDC
----	43	Speed Sensor
----	42	Pulley Sensor
----	41	Plug Sensor
----	40	Head Rub - Right (T#12)
----	39	Head Rub - Left (T#11)
3A	38	Head Align - Right
2A	37	Head Align - Left
5 (1)	36	+24 VDC (F1)

WDC3	WDC4	WDC4 Terminal
1	35	0 VDC
----	34	Tail Rub - Right (T#10)
----	33	Tail Rub - Left (T#9)
3B	32	Tail Align - Right
2B	31	Tail Align - Left
5 (1)	30	+24 VDC (F2)

WDC3	WDC4	WDC4 Terminal
----	29	0 VDC
----	28	Bearing Temp Sensor (T#6)
----	27	Bearing Temp Sensor (T#5)
4D	26	Bearing Temp Sensor (T#4)
4C	25	Bearing Temp Sensor (T#3)
4B	24	Bearing Temp Sensor (T#2)
4A	23	Bearing Temp Sensor (T#1)
----	22	Ambient Sensor 2 (T#8)
----	21	Ambient Sensor 1 (T#7)
----	20	+24 VDC (F3)

9.7 SENSOR WIRING DIAGRAM PROFILE WITH TOUCHSWITCHES -

MENU > SETUP (PASSWORD) > PROFILE > SELECT NEW PROFILE > LEG (TS)/ 1SP, 4BS, 4TS

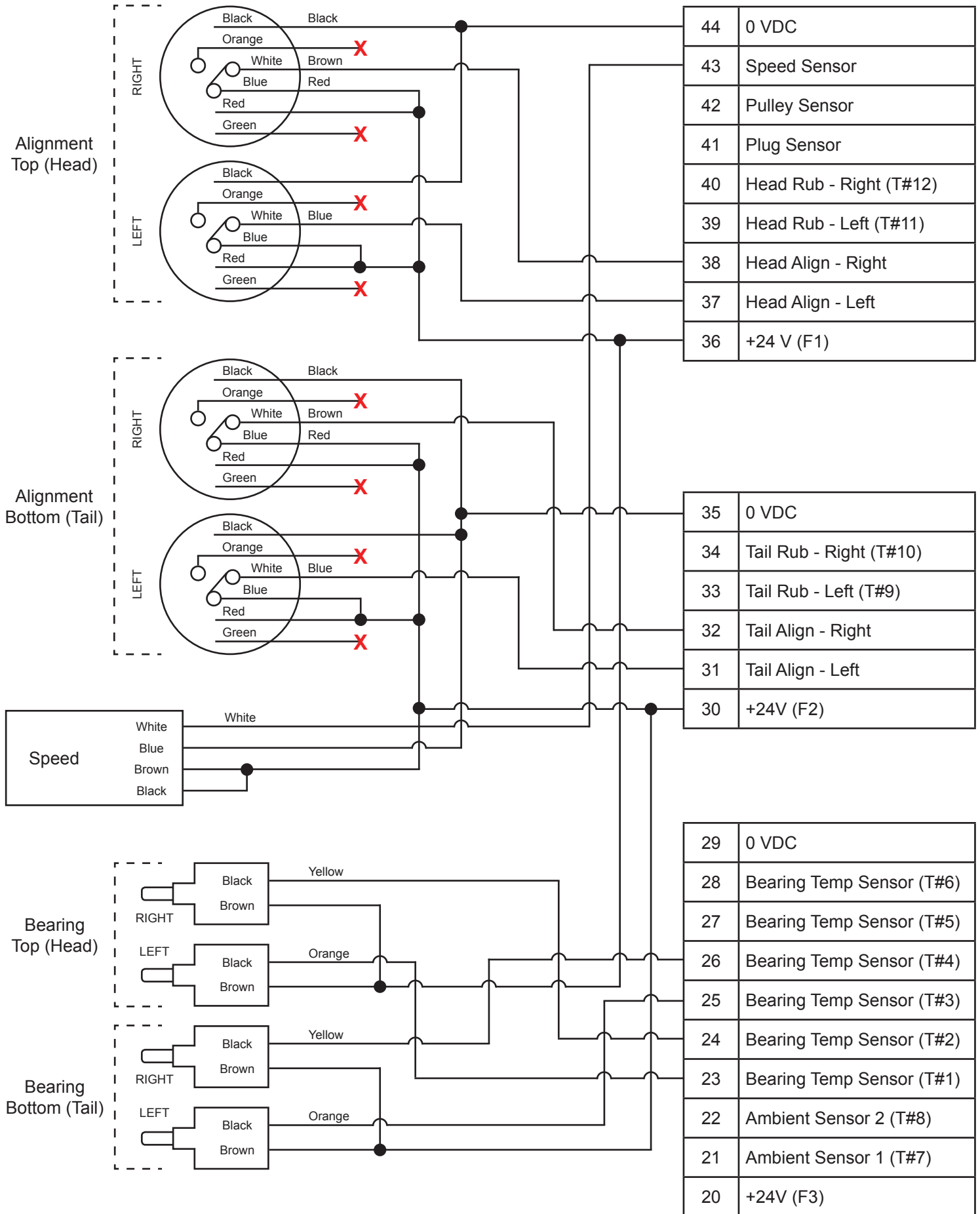

9.8 SENSOR WIRING DIAGRAM PROFILE WITH RUB BLOCKS -

MENU > SETUP (PASSWORD) > PROFILE > SELECT NEW PROFILE > LEG (RB)/ 1SP, 4BS, 4RB

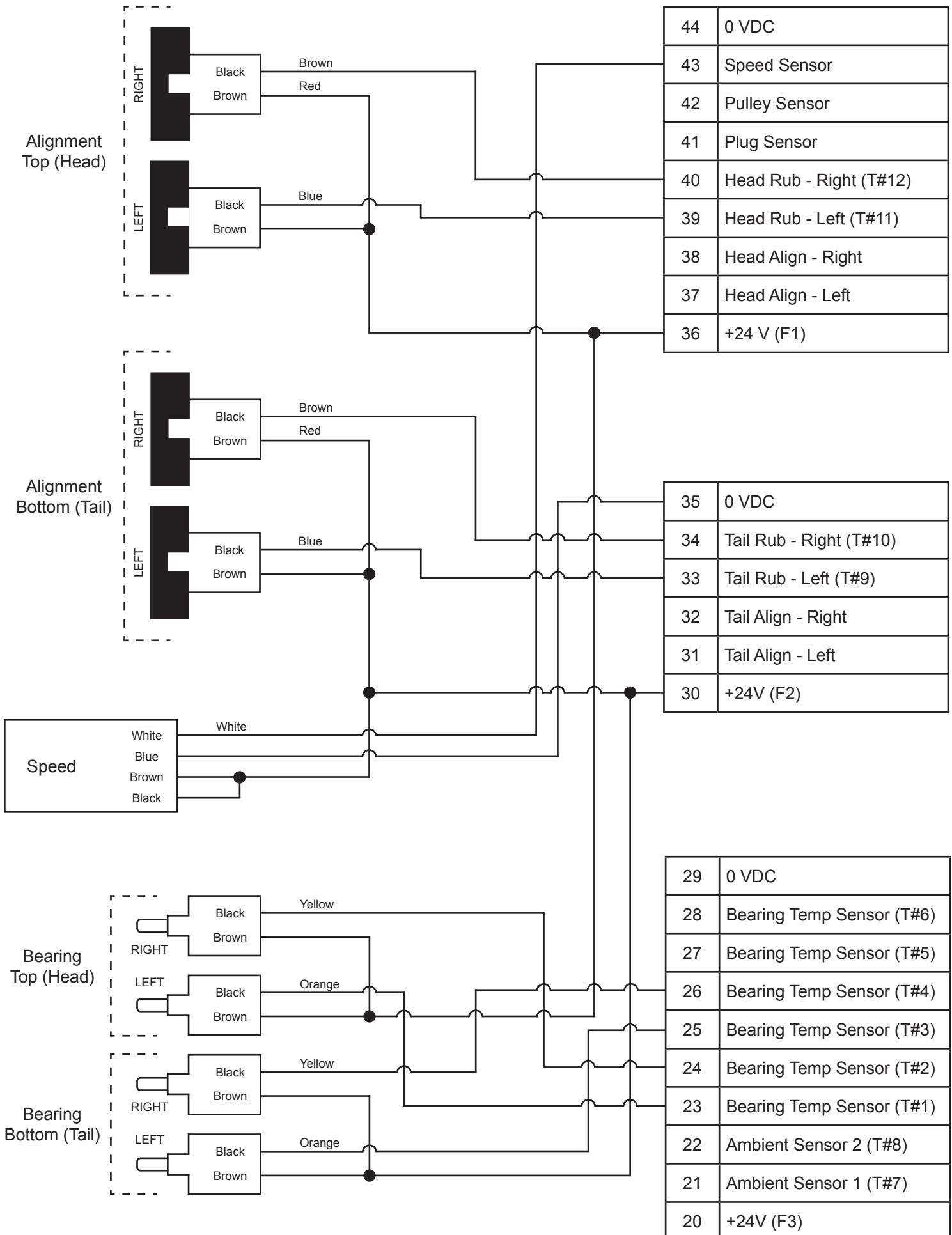

9.9 SENSOR WIRING DIAGRAM PROFILE WITH MOTION ALIGNMENT SENSORS -

MENU > SETUP (PASSWORD) > PROFILE > SELECT NEW PROFILE > LEG (WDA) 4MA, 4BS

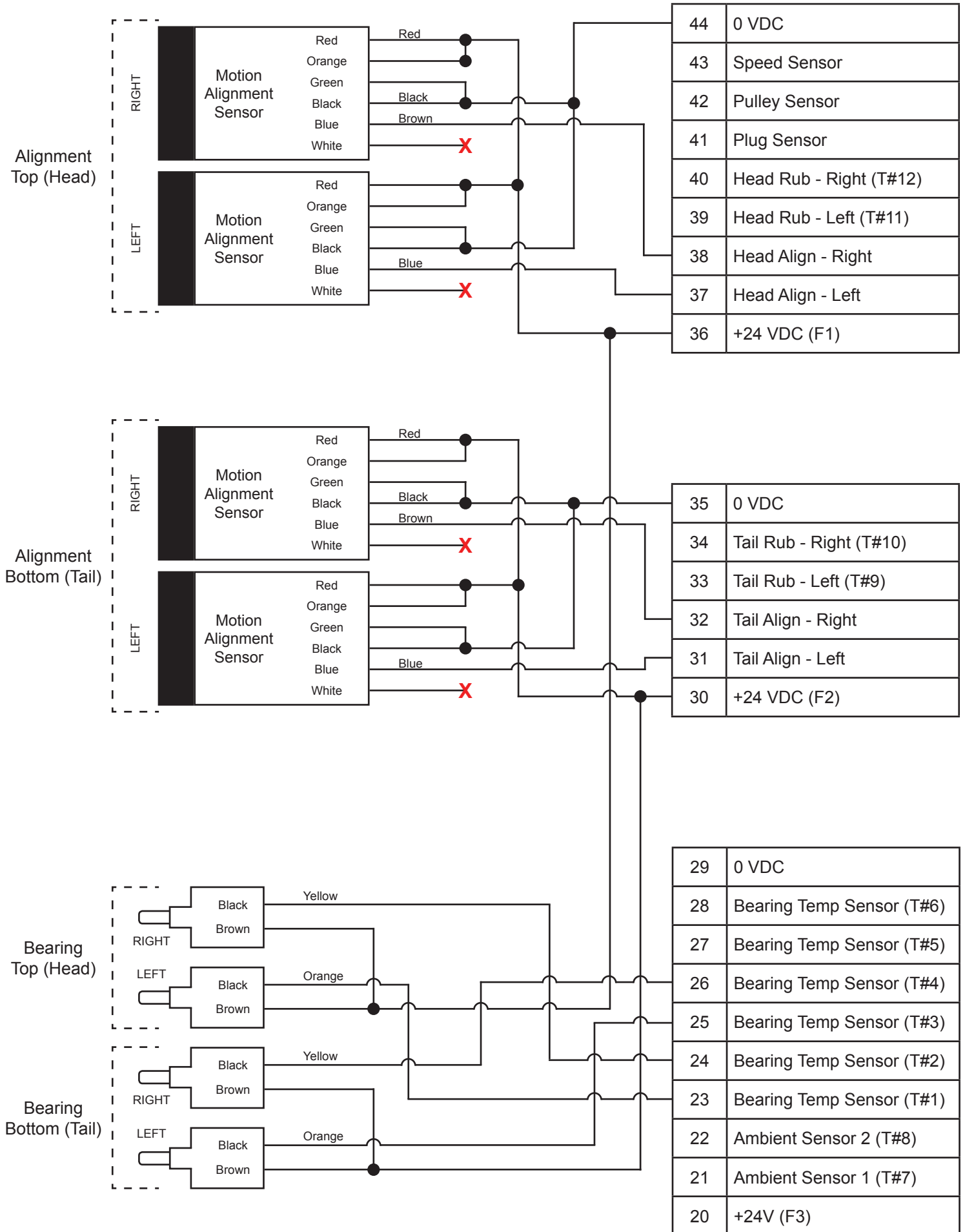

9.10 SENSOR WIRING DIAGRAM PROFILE WITH KNEE OR IDLER PULLEYS -

MENU > SETUP (PASSWORD) > PROFILE > SELECT NEW PROFILE > LEG (TS)/ 1SP, 6BS, 6TS

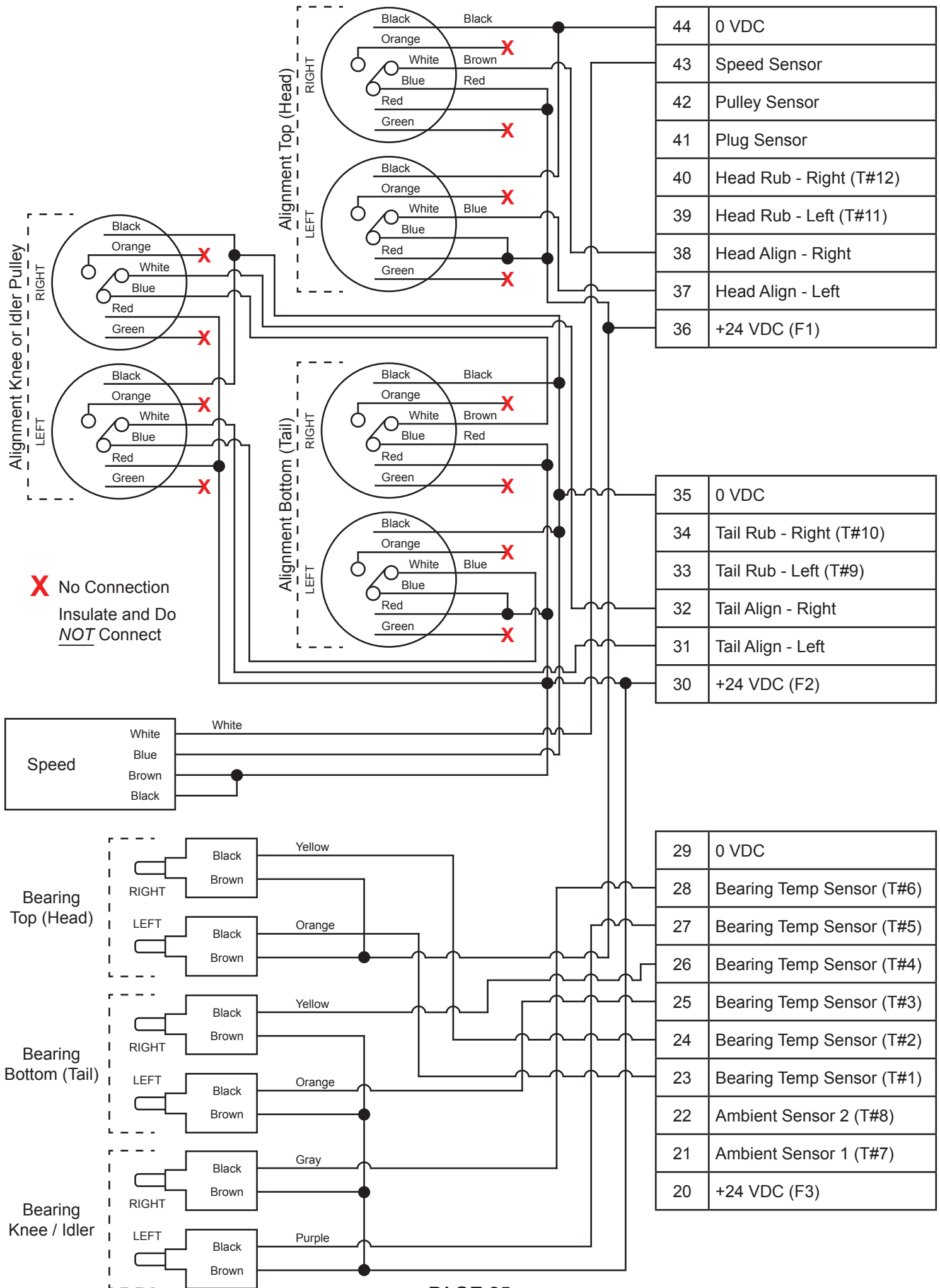

WARNING

For any new installation go through a FULL SYSTEM SETUP or select a pre-installed NEW PROFILE, and then choose CALIBRATE SYSTEM before using the Watchdog for the first time.

NOTE

Appendix A provides a menu tree to help guide you through all of the Watchdog's available menu screens and settings.

All new Watchdogs are pre-set to the factory default values (Appendix B).

10. WATCHDOG MAIN LCD SCREEN



Image 3
Initial Power Up Screen

10.1 START UP SCREEN (INITIAL POWER UP) -

When power is first applied to the Watchdog WDC4, an opening start-up screen will be displayed for around 5 seconds (Image 3). The software version (Main IC) for the Watchdog will be listed during start-up, this will be required should you need to contact 4B for technical support.

The WDC4 is normally supplied with its programmable parameters preset to factory default settings. Appendix B consists of a number of tables giving all the allowable values. The adjustment of each parameter is accessed through the EDIT SELECTED PROFILE menu. This menu requires an engineering password to access and change any system settings.

NOTE

Image 3 shows generic firmware versions and database sizes for illustration purposes, actual screen information will vary.

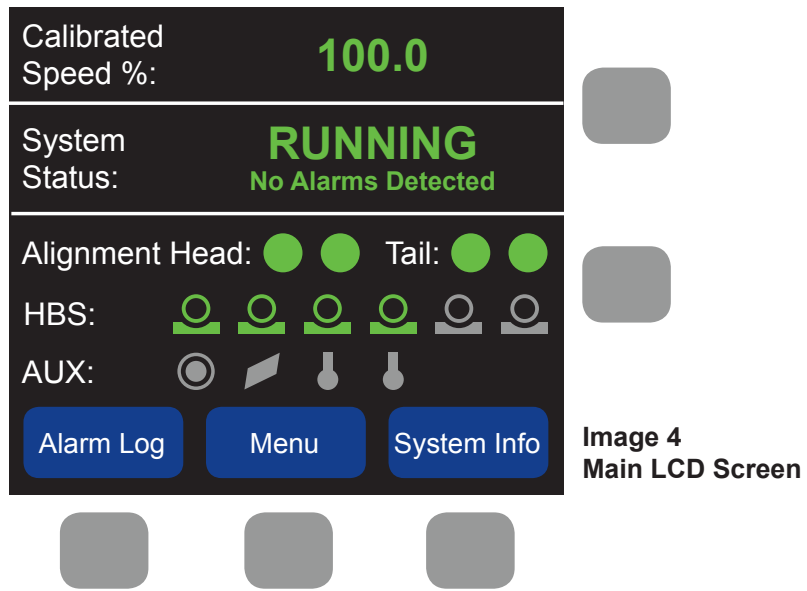

10.2 MAIN LCD SCREEN & SENSOR LEDES -

The Watchdog's LCD screen is not touch sensitive, do not confuse the blue text menus on the LCD with the actual push buttons (shown in grey). The function of a button is indicated by the blue text menu displayed on the LCD screen immediately above or to the left of each button and varies according to the screen being displayed.

The main LCD screen (Image 4) shows the overall status of the Watchdog. The top line shows the running speed. In this instance it shows the speed of the elevator or conveyor as a percentage of the total calibrated speed. The next line shows the system status and any current faults or alarm conditions. Under system status you can see the status for all of the sensors: alignment, bearing temperature and auxiliary sensors. Disabled sensors are grey, if a sensor is enabled it becomes highlighted in red, green or amber. Green signifies the sensor is in a normal state. Red indicated the sensor is in Alarm. Amber relates to the temperature sensors and indicates a fault with the sensor or the sensor wiring.



The sensor LEDs provide a quick view status of the head and tail alignment sensors (top left, top right, bottom left, bottom right), along with pulse indication and alarm and stop status (Image 5).

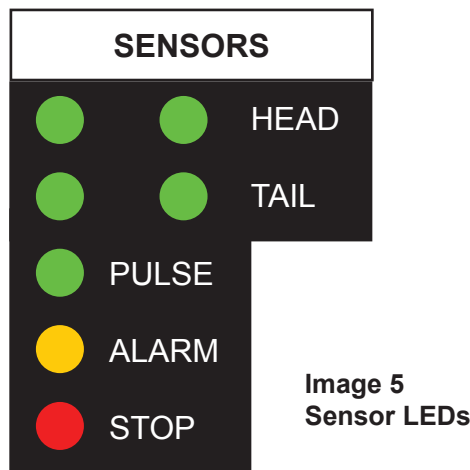

10.3 ALARM LOG BUTTON -

To view the last 40 events and alarms, press the ALARM LOG button on the main screen (Image 3). The alarm log screen should now appear (Image 5). Pressing the UP and DOWN arrows allows you to scroll through the alarms. Pressing the MORE INFO button gives details of the highlighted alarm. Cleared alarm conditions are also logged. If an SD card is installed, all alarm details (not just the last 40) will be stored on the card.

⚠ WARNING

If the SD card is removed and more alarms occur, they will not be logged when the SD card is re-inserted. For uninterrupted historical data logging, 4B recommends using HazardMon.com.

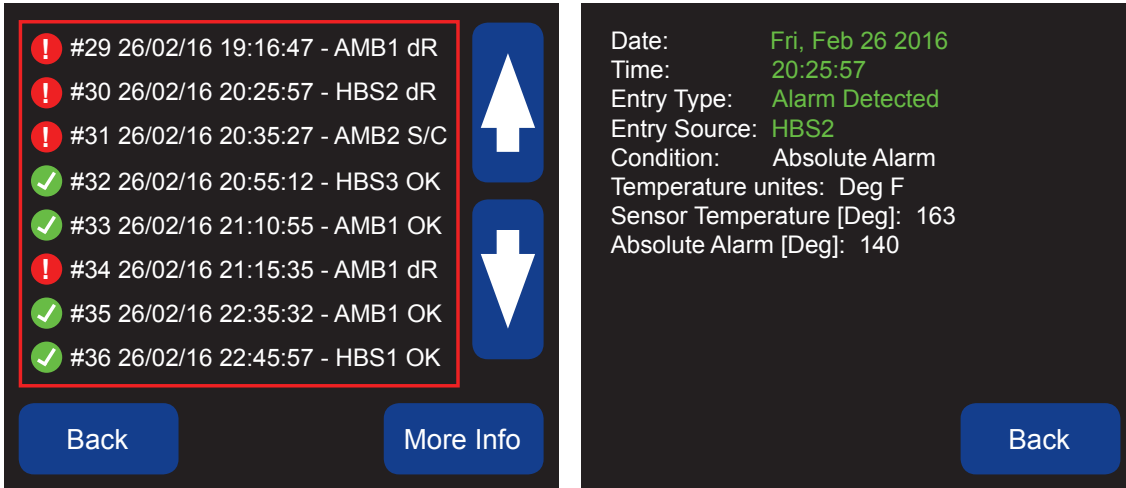

Image 6
Alarm Log / More Info

10.4 MENU BUTTON -

The MENU button allows access to all of the sub menu functions. Most of the sub menu areas require the entry of a password. Please refer to section 12.1 for information about the password.

10.5 SYSTEM INFO BUTTON -

The SYSTEM INFO button allows the viewing of the system information screens (1 - 9). No password is required to enter these screens. Press NEXT or PREVIOUS to scroll forward or backward through the each of the screens. The EXIT button terminates the function and returns you back to the main screen. See pages 28 - 31 for screen images for each of the seven system info screens.

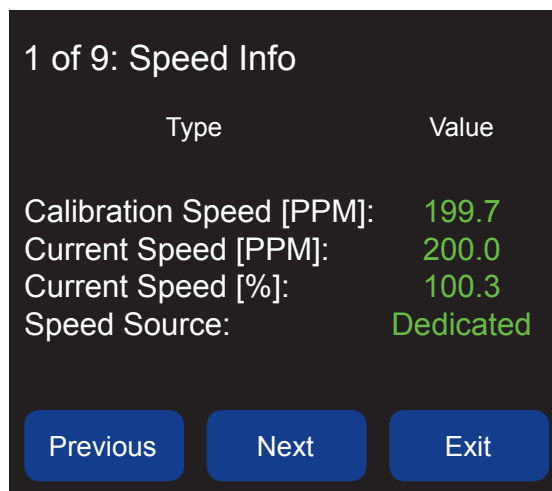

Image 7
Speed Info

10.6 SPEED INFO (1 OF 9) -

The speed info screen (Image 7) shows information regarding the calibrated speed (PPM - pulses per minute), current speed (PPM - pulses per minute), current speed (percentage) and the speed source (detection method). Refer to 14.5 for more detail about speed settings.

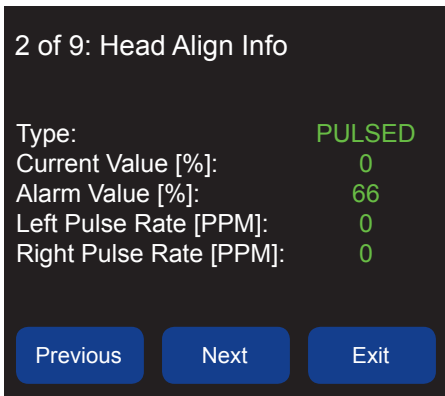

Image 8-A
Head Align Info - Pulsed Sensor

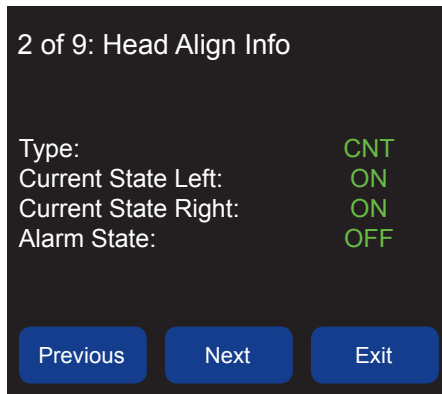

Image 8-B
Head Align Info - Contact Sensor

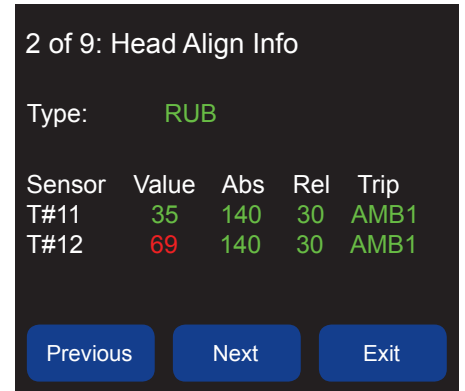

Image 8-C
Head Align Info - Rub Block Sensor

10.7 HEAD ALIGN INFO (2 OF 9) -

The head align info screen shows the head alignment sensor type and the current values for the sensor. The sensor type can be off, pulsed, contact (CNT) or rub block (RUB). The display will vary depending upon the sensor type (Image 8 A-C). Refer to section 14.6 for more information about head alignment settings.

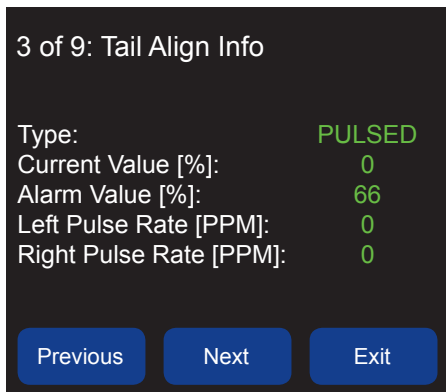

Image 9-A
Tail Align Info - Pulsed Sensor



Image 9-B
Tail Align Info - Contact Sensor

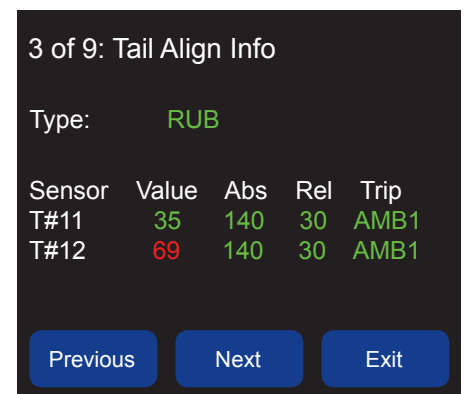

Image 9-C
Tail Align Info - Rub Block Sensor

10.8 TAIL ALIGN INFO (3 OF 9) -

The tail align info screen shows the tail alignment sensor type and the current values for the sensor. The sensor type can be off, pulsed, contact (CNT) or rub block (RUB). The display will vary depending upon the sensor type (Image 9 A-C). Refer to section 14.7 for more information about tail alignment settings.

4 of 9: HBS Info				
			AMB 1:	86.4
			AMB 2:	87.6
Sensor	Value	Abs.	Rel.	Trip
HBS#1	112	140	30	N/A
HBS#2	102	140	30	N/A
HBS#3	112	140	30	N/A
HBS#4	163	140	30	N/A
HBS#5	OFF	N/A	N/A	N/A
HBS#6	OFF	N/A	N/A	N/A

Previous Next Exit

Image 10
HBS Info
Temperature Sensors

10.9 HBS INFO (4 OF 9) THRU (6 of 9) -

The hot bearing sensor (HBS) screens show the actual temperature value (Value) of all the enabled bearing sensors and any selected absolute (Abs.) and relative (Rel.) alarm trip points. Where bearing sensors are not selected, the value will show OFF and the remaining information will be displayed in grey. Normal temperature values are displayed in green, and will change to red when the sensor value is in an alarm state.

- Screen 4 shows information for sensors HBS#1 - HBS#6
- Screen 5 shows information for sensors HBS#7 - HBS#12 (NTC expansion board required)
- Screen 6 shows information for sensors HBS#13 - HBS #18 (NTC expansion board required)

Refer to section 14.8 for more information regarding temperature settings.

NOTE

HBS INFO can refer to any NTC type temperature sensor. While originally developed for displaying hot bearing sensors (HBS), these menus can refer to any NTC type temperature sensor such as those used with brass rub blocks (ADB Series) or surface temperature sensors (WDB7 Series).

7 of 9: AUX Sensor Info	
Plug	
Current State:	-
Alarm State:	-
Pulley	
Current State:	-
Alarm State:	-

Previous Next Exit

Image 11
AUX Sensor Info

10.10 AUX SENSOR INFO (7 OF 9) -

The Watchdog supports two auxiliary sensors, pulley alignment “Pulley” and plug condition “Plug”. The AUX Sensor Info screen (Image 11) shows the current enabled and alarm state for these sensors. Refer to section 14.9 for more information regarding the auxiliary sensors.

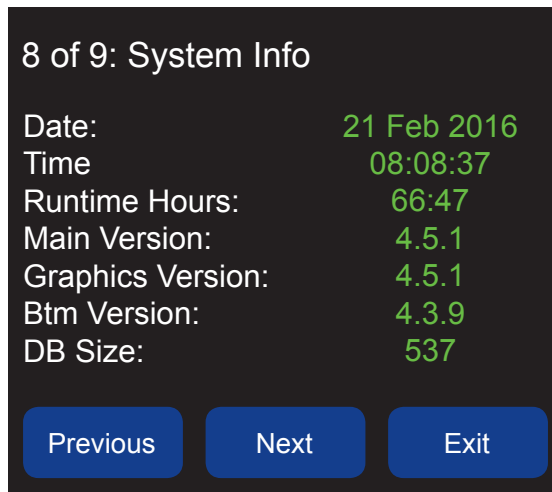

Image 12
System Info

10.11 SYSTEM INFO (8 OF 9) -

The system info screen (Image 12) shows the time and date along with the number of runtime hours elapsed. The runtime is the actual number of run hours that the equipment has been running and not how long the Watchdog has been switched on. Refer to section 18 for more information about setting the time and date. This screen also shows the software versions and database size.

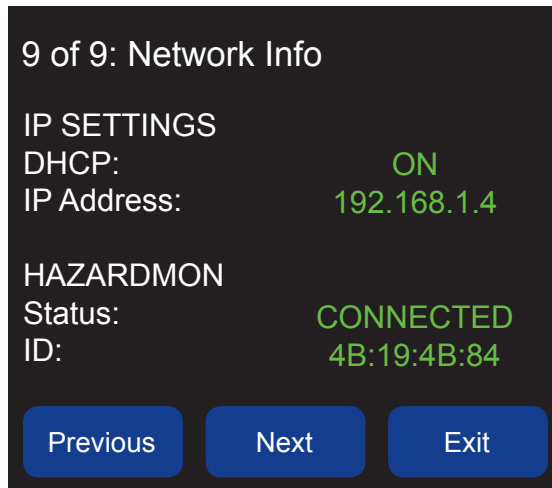

Image 13
Network Info

10.12 NETWORK INFO (9 OF 9) -

The Watchdog has an advanced interface to allow the remote monitoring of data through an Ethernet connection. This cloud based monitoring system is known as HazardMon.com, and the network info screen (Image 13) shows the settings required to use HazardMon.com. These settings are adjustable and the information is made available for the purposes of diagnostics.

HazardMon.com network settings can be found in the Network Settings Menu (Section 20).

For more information about HazardMon.com, contact 4B or visit us on the web at www.go4b.com/usa.

11. VIEW SETTINGS

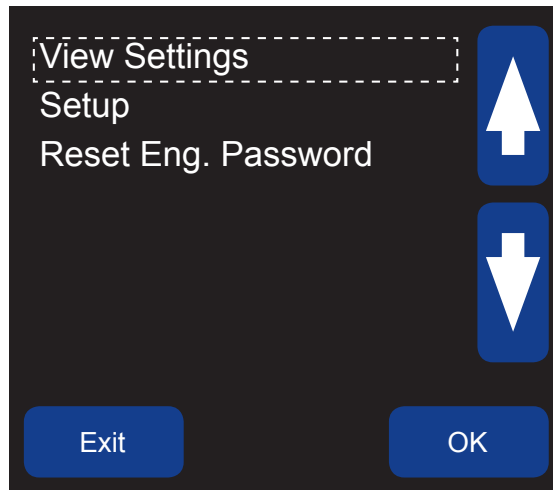

Image 14
View Settings

11. VIEW SETTINGS -

MENU > VIEW SETTINGS

Due to the total number of screens used within the view settings menu, not all will be illustrated.

You can view the system settings on the Watchdog without a password by choosing VIEW SETTINGS from the menu (Image 14). This will allow you to scroll through all of the current settings for the SYSTEM, SPEED, ALIGNMENT, TEMPERATURE and AUXILIARY menus.

The number of pages and information in each section will vary depending upon what settings are chosen for each section. For example, in the TEMPERATURE menu, if HBS1 (hot bearing sensor) is not enabled, then the setting details for HBS1 will not be displayed.

This is a read only area, no changes can be made within the VIEW SETTINGS menu. Changes can only be made under SETUP or FACTORY SETTINGS, which are password protected menus.

NOTE

Settings shown in yellow text indicate that the value is locked. The value can only be modified within the FACTORY SETTINGS menu, which requires an administrator password.

12. SETUP

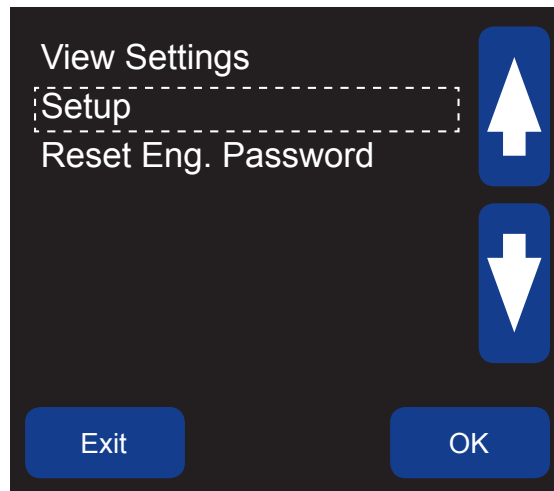

Image 15
Setup

12. SETUP -

MENU > SETUP (PASSWORD)

There are seven password protected settings within the setup menu (Image 15): PROFILE, TEST, FACTORY SETTINGS, SD CARD, TIME & DATE, CHANGE PASSWORD and NETWORK. All of these settings are explained in detail within individual sections of this manual.

12.1 PASSWORD -

In order to make any system changes to the Watchdog, an engineering password is required. The default engineering password set at the factory is BBBB.

You can change the password from the factory setting within this menu by choosing CHANGE PASSWORD. The password is from 1 to 8 characters long, and can be any combination of the letters A, B and C. If you change the password from the factory default, make a note of your new password.

NOTE

If the engineering password has been changed from the factory default and you have forgotten your new password, contact 4B for assistance.

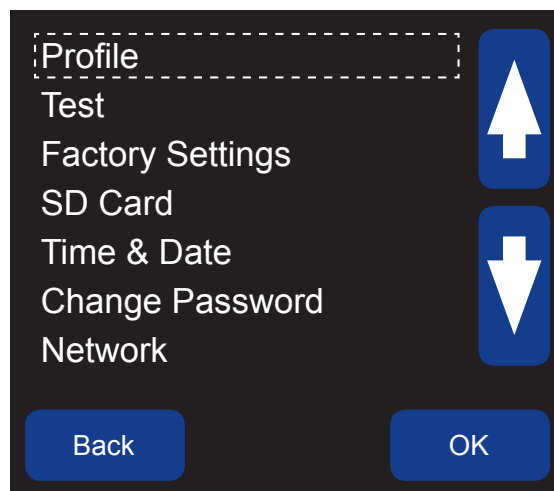

Image 16
Setup Menu

NOTE

Settings shown in yellow text indicate that the value is locked. The value can only be modified within the FACTORY SETTINGS menu, which requires an administrator password.

13. RESET ENGINEERING PASSWORD

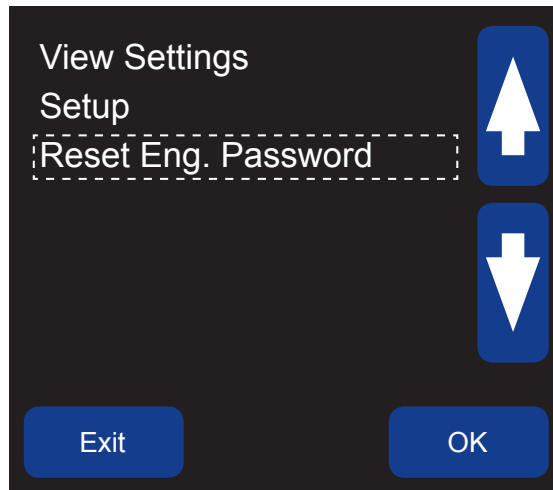

Image 17
Reset Engineering Password

13. RESET ENGINEERING PASSWORD -

MENU > RESET ENG. PASSWORD

If the engineering password has been changed from the factory default and you have forgotten your new password, it can be reset. In order to perform a password reset, you will need to contact 4B technical support and supply them with the four digit code displayed on the RESET ENG. PASSWORD screen (Image 18). Once your code has been verified by the 4B technician, they will provide a secondary code to enter into your unit which will reset the engineering password back to the factory default of BBBB).

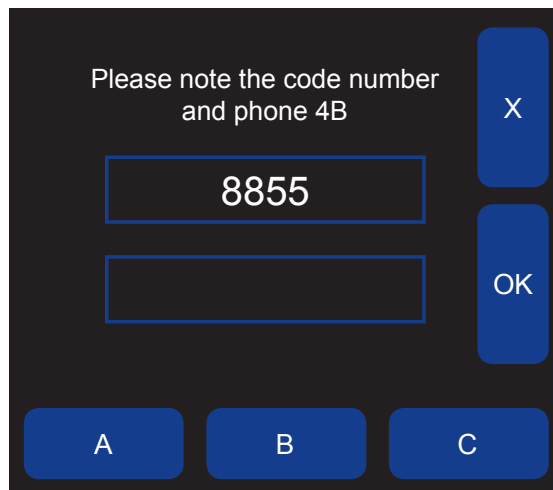

Image 18
Reset Engineering
Password Screen

14. PROFILE

14. PROFILE -

MENU > SETUP (PASSWORD) > PROFILE

The first choice under the SETUP menu is PROFILE (Image 16), which allows you to edit individual section settings without having to go through the entire FULL SYSTEM SETUP. Once PROFILE has been selected, you will see the next sub-menu (Image 19) where you can EDIT SELECTED PROFILE, RESTORE DEFAULTS or SELECT NEW PROFILE.

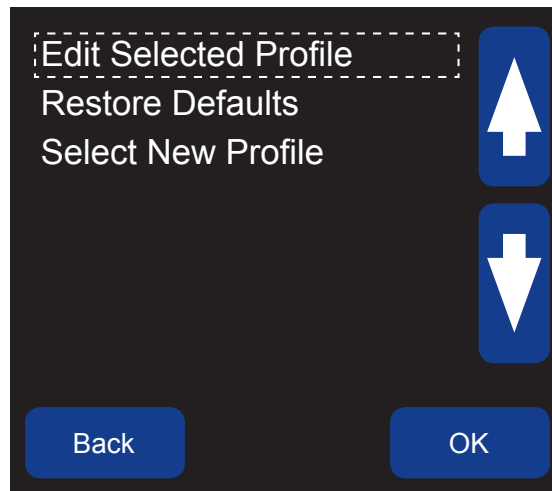

Image 19
Profile Menu

14.1 EDIT SELECTED PROFILE -

MENU > SETUP (PASSWORD) > PROFILE > EDIT SELECTED PROFILE

Menu choices in this sub-menu (Image 20) include: CALIBRATE SYSTEM, FULL SYSTEM SETUP, SYSTEM, SPEED, ALIGNMENT, TEMPERATURE and AUXILIARY.

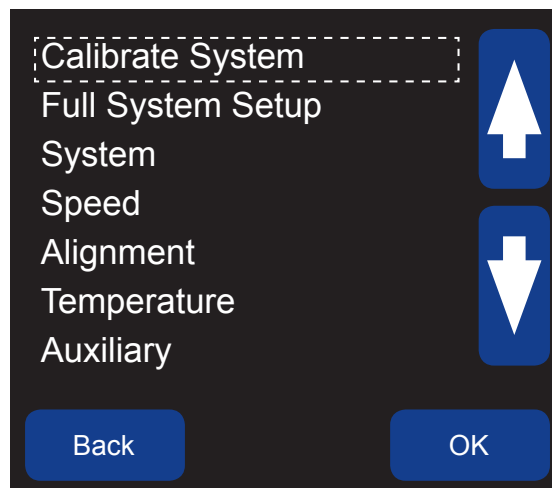

Image 20
Edit Selected Profile Menu

NOTE

Settings shown in yellow text indicate that the value is locked. The value can only be modified within the FACTORY SETTINGS menu, which requires an administrator password.

WARNING

When you have completed making changes to the Watchdog profile setup, you will be prompted to save your changes. You must enter YES, or your changes will not go into effect.

NOTE

When the Watchdog is powered up it reads the stored setup parameters from its memory. These will be used during operation. New Watchdogs are set to the factory default values (Appendix B).

14.2 CALIBRATE SYSTEM -

MENU > SETUP (PASSWORD) > PROFILE > EDIT SELECTED PROFILE > CALIBRATE SYSTEM

The Watchdog must be calibrated to correctly monitor the speed of an elevator or conveyor belt.

Select CALIBRATE SYSTEM in the menu section (Image 20). Press the CALIBRATE button, you will then be asked to start the elevator or conveyor. A progress bar will display the calibration percentage (Image 21). After calibration is complete, the screen will display CALIBRATION SUCCESSFUL and the LCD will return to the main screen. If the calibration procedure fails, the screen will display NOT CALIBRATED CALIBRATION FAILED! If this occurs, follow the SYSTEM RECALIBRATION instructions below.

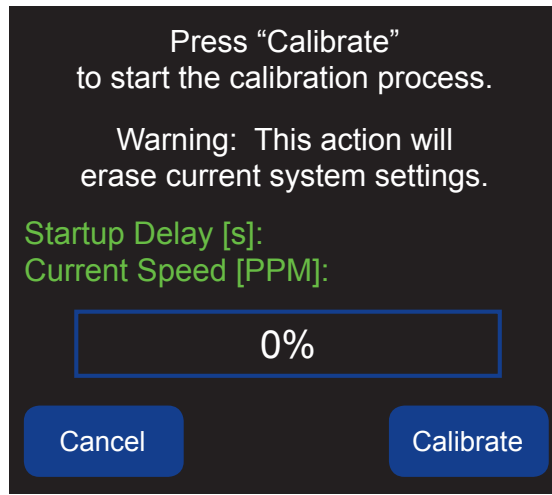

Image 21
Edit Selected Profile -
Calibrate System

- **14.2.A SYSTEM RECALIBRATION** - The Watchdog can be re-calibrated at any time while the machine is running normally by selecting the CALIBRATE SYSTEM option as described above. You are strongly advised against indiscriminate re-calibration, as you may be attempting to calibrate the unit when the machine is not running normally. If you have persistent alarm/stop conditions there is something wrong with the machine or with the adjustment of the system.

If the STOP button is operated on the motor starter (interlock signal removed) during calibration, the Alarm and Stop relays will be de-energized and calibration will be aborted. Calibration will also be aborted if any fault conditions occur, i.e. the elevator fails to start, or stops during the procedure. Start calibration again if this happens, proceed from section 14.2 above, after rectifying the fault condition.

- **14.2.B INCORRECT CALIBRATION** - If the unit was calibrated at less than normal speed, it will display an over speed alarm / stop condition and possibly stop the machine when running at normal speed. This indicates that the calibration is incorrect and the belt tension should be checked and adjusted as required. The unit should then be re-calibrated (see section 14.2.A).
- **14.2.C START UP TIMER** - When the equipment being monitored starts, the Watchdog's motor interlock input is energized and a start-up timer begins to time out. When the start-up timer expires, the input speed is compared to the calibrated speed. If the input speed is within the preset limits no action is taken, however if it is not an alarm will occur.

NOTE

If you proceed with the calibration cycle, the current calibration settings will be erased. If you do not wish to continue with the calibration cycle press the CANCEL button.

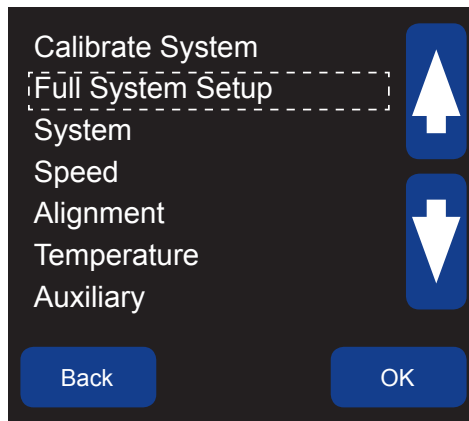

Image 22
Edit Selected Profile -
Full System Setup

14.3 FULL SYSTEM SETUP -

MENU > SETUP (PASSWORD) > PROFILE > EDIT SELECTED PROFILE > FULL SYSTEM SETUP

Watchdog control units are preset with factory default values (Appendix B). All new installations should go through either a FULL SYSTEM SETUP or use one of the pre-installed profiles available under SELECT NEW PROFILE (section 14.11) before using the Watchdog for the first time.

FULL SYSTEM SETUP will guide you through each of the five sections: SYSTEM, SPEED, ALIGNMENT, TEMPERATURE, and AUXILIARY. These can also be accessed individually as outlined below.

After the Watchdog has been setup, all settings will be stored within the controller's memory.

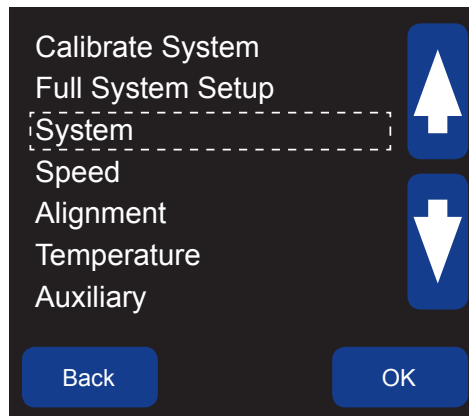

Image 23
Edit Selected Profile -
System

14.4 SYSTEM -

MENU > SETUP (PASSWORD) > PROFILE > EDIT SELECTED PROFILE > SYSTEM

- **14.4.A TEMPERATURE UNITS (1 of 6)** - Fahrenheit (°F) or Celsius (°C) can be selected. The default is Fahrenheit. The Watchdog will reset temperatures to the factory default settings if the temperature unit is changed, be sure to check all settings if this occurs to ensure proper operation.
- **14.4.B PRE ABS ALARM (2 of 6)** - Can be turned ON or OFF (default). If turned ON, and the bearing temperature increases to within 10° F (5° C) of either the RUB BLOCK ABSOLUTE ALARM (section 14.6.C), the HBS ABSOLUTE ALARM (section 14.8.B), or the AMB ABSOLUTE ALARM (section 14.8.I) an alarm will occur. The system will not shut down due to this alarm, however if the equipment is stopped it can not be re-started until this alarm has been cleared. The alarm event is also logged in the ALARM LOG.
- **14.4.C NEGATIVE DIFFERENTIAL ALARM (3 of 6)** - Can be turned ON or OFF (default), and is used when monitoring temperature using a relative ambient temperature alarm source. During normal operation, it would be unusual for the bearing temperature value to be below that of the ambient temperature source (default OFF). If turned ON, and a bearing temperature value drops below the value of the ambient source by an amount greater than the relative alarm value, an alarm will occur. The alarm is logged in the ALARM LOG.
- **14.4.D RATE OF RISE START UP DELAY [MIN] (4 of 6)** - Allows a delay when the system is started before any rate of rise in temperature is monitored. This allows the system to reach a steady state before alarming. This level setting can be set from 0 - 5 minutes, the default is 5.

Additional expansion boards can be installed inside the Watchdog WDC4 in positions EXP1 and EXP2.

1. NTC expansion board (WDC4-AUXI-6NTC) provides the ability to connect 6 additional NTC temperature sensors to the WDC4. A maximum of two can be installed, providing a total of 12 additional NTC inputs.
2. PLC expansion board (WDC4-AUXO-4SSR) provides the ability to connect additional signals from the WDC4 to a PLC. The board has 4 Solid State Relays that can be used to indicate alarm conditions related to speed, alignment, temperature and auxiliary alarms as four separate signals. A maximum of two can be installed, providing a total of 8 separate alarm signals.

Board types can be installed in pairs as describe above, or mixed (1 NTC and 1 PLC). Boards can be pre-installed at the factory when ordering a new Watchdog WDC4, or installed into existing control units already in the field. For installation instructions and board specifications, refer to either the NTC or PLC expansion board manual.

- **14.4.E EXPANSION 1 (5 of 6)** - Choices are NTC BOARD, RELAY BOARD or OFF (default) as shown in the system settings screen (Image 24). If NTC BOARD or RELAY BOARD are selected, you will need to confirm your selection by choosing YES to save the new setting (Image 25).
- **14.4.F EXPANSION 2 (6 of 6)** - Choices for expansion board 2 are the same as expansion board 1 above (14.4.E).

NOTE

For NTC expansion boards, you will need to edit the profile settings for temperature sensors (14.8).
MENU > SETUP (PASSWORD) > PROFILE > EDIT SELECTED PROFILE > TEMPERATURE

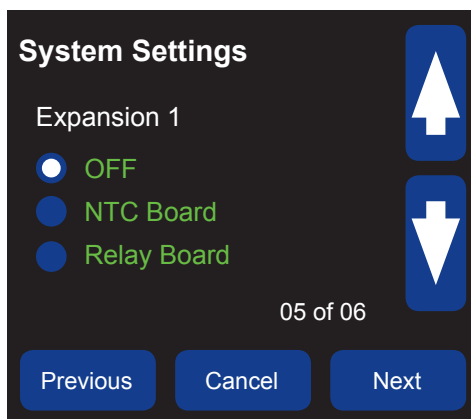

Image 24
Expansion Boards (1 of 2 Shown)

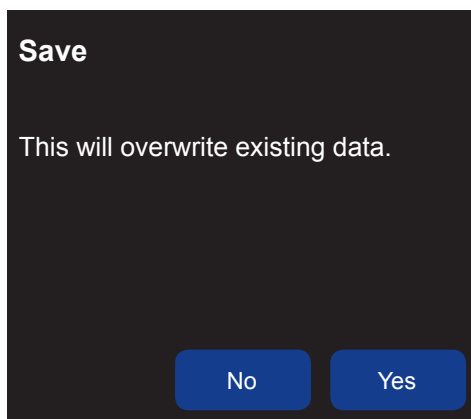

Image 25
Expansion Board Confirmation

WARNING

Expansion boards are NOT suitable for HOT INSTALL. Expansion boards should NOT be installed while the WDC4 is powered. Refer to the board's manual for installation information or contact 4B.

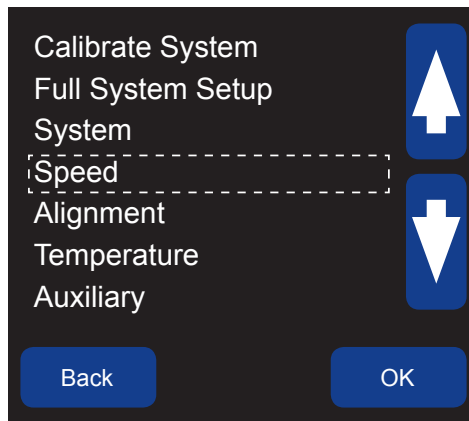

Image 26
Edit Selected Profile -
Speed

14.5 SPEED -

MENU > SETUP (PASSWORD) > PROFILE > EDIT SELECTED PROFILE > SPEED

- **14.5.A SPEED MONITORING** - This section allows you to enable or disable speed monitoring. The default setting is ON, but it can only be disabled by selecting OFF in the FACTORY SETTINGS menu (Section 16).
- **14.5.B SCALING UNITS** - Allows the selection of the main screen speed units. Four options are available:
 1. PPM - Pulses Per Minute
 2. RPM - Revolutions Per Minute
 3. USR - User Defined
 4. % - Percentage of Calibrated Speed (Default)
- **14.5.C SCALING FACTOR** - If either RPM or USR is selected then a scaling factor must be entered. The default value is 20.

PPM and % are automatically calculated. $\text{Display} = (\text{Input PPM} \times \text{Scale factor}) / 12$.

1. Example: Tons / Hour -
If the elevator normal speed is 420 pulses per minute (PPM) and the desired display is 3000 tons /hour then the scale factor = $(3000 \times 12) / 420 = 85.71$.
 2. Example: Feet / Min -
If there are 9 inches between each bucket and you wish to display speed in feet / minute then set the scale factor to 9. This is a special case of when the scale factor is set to the bucket spacing in inches then the display will show belt speed in feet / minute.
 3. Example: Meters / Min -
Scale factor = $12 \times \text{bucket pitch in meters}$. If the pitch is 23 cm, then the scale factor = $(12 \times 0.23) = 2.76$.
- **14.5.D SPEED DETECTION SOURCE** - Three options determine the different ways to measure speed.

1. MAS SPEED INPUT -

This option is selected when you intend to use multiple speed detectors such as WDA. MAS (Motion and Alignment Sensor) detectors are usually used to detect the passage of buckets when the elevator belt is in motion. As each bucket passes the sensors a pulse is generated and the Watchdog uses these pulses to measure speed and the alignment of belt between the sensors.

2. DEDICATED SPEED INPUT (Default) -

The dedicated speed input is selected when a single speed sensor is to be used. Usually this sensor is used with a Whirligig and is connected to the boot / tail end of the elevator or conveyor belt. The Watchdog uses the pulses from the sensor to determine speed.

3. DIFFERENTIAL SPEED -

Differential speed monitoring is selected when you intend to monitor an elevator or conveyor belt that may intentionally vary in speed as part of the process or when that belt is driven by a variable speed controller.

The monitoring of differential speeds usually takes place between the top of the elevator (the drive end) and the bottom (the driven end). This allows the varying speed to be monitored while comparing the drive speed with the driven speed, differences between the two being the result of belt slippage.

Once differential speed is enabled the Watchdog expects 2 independent signals by which to measure the speed of an elevator or conveyor belt. This method allows the monitoring of both fixed and variable speed elevators.

The 2 speed inputs are connected in the following manner.

Speed 1 is connected to the dedicated speed input. The source for the pulses is usually a Whirligig mounted on the head (or main) drive assembly.

Speed 2 can be derived from a number of different sources but will usually be connected to either the head alignment sensor inputs, tail alignment sensor inputs or both head and tail together.

The source for the speed can also be derived from a Whirligig connected to the tail shaft (or driven), the pulsed output being passed through the Touchswitch alignment sensor pairs into the Watchdog alignment inputs.

An alternative speed source could be from WDA alignment sensors (MAS) installed to detect buckets on the elevator belt. When MAS are used the Watchdog always uses the highest speed input for speed 2.

For the differential speed option to work correctly it is necessary to enable alignment monitoring on either the tail and/or head and for them to be set as "Pulsed" inputs.

The speed monitoring is performed by comparing the two different speed sources. They do not need to be the same speed since the speed is determined by checking the difference between the two speeds or rather the ratio of one speed to the other. Because speed 2 is connected to 2 or 4 inputs, the highest measured speed is always used.

Although calibration is not required in the usual way on a variable speed elevator it is used to determine the ratio of speed 1 to speed 2. This approach allows two completely different pulse rates to be compared and if either changes in relationship to the other action can be taken.

During the calibration cycle the Watchdog checks the two different speeds and calculates the RATIO of one to the other. After the calibration cycle is complete this ratio is used to determine if there is any difference in relationship between the speeds. If this difference is sufficient then the Watchdog reacts in the usual manner and will generate an alarm or stop action depending upon the outcome of the compare.

Because the relationship between the two speeds determines the action to be taken the speed of the elevator can rise and fall (variable speed) and as long as the two speeds are in the same relationship (ratio) to each other, the Watchdog will not generate a fault condition.

The permitted ratio is 0.1 to 10.0, values outside this range will result in a calibration failure.

WARNING

When you have completed making changes to the Watchdog profile setup, you will be prompted to save your changes. You must enter YES, or your changes will not go into effect.

Below are examples of how the Watchdog sees the two speeds:

- Example 1:

Speed 1 - 426 PPM

Speed 2 - 987 PPM

Ratio of speed 2 to speed 1 = 2.316 (987/426)

If the elevator was to increase in speed so that speed 1 was now 556 PPM then speed 2 should be speed (556 X 2.316) or 1288 PPM (these figures are rounded).

Speed 1 at 426 PPM and speed 2 at 987 PPM has the same relationship as speed 1 at 556 PPM and speed 2 is 1288 PPM. In both cases the elevator is running at 100% or the relationship of the two speeds is 100% of the expected ratio.

- Example 2:

Speed 1 - 583 PPM

Speed 2 - 416 PPM

Ratio of speed 2 to speed 1 = 0.713 (416/583)

If the elevator was to decrease in speed so that speed 1 was now 480 PPM then speed 2 should be speed (480 X 0.713) or 342 PPM (these figures are rounded).

Speed 1 at 583 PPM and speed 2 at 416 PPM has the same relationship as speed 1 at 480 PPM and speed 2 as 342 PPM. In both cases the elevator is running at 100% or the relationship of the two speeds is 100% of the expected ratio.

Once the ratio between speed 1 and 2 is established then it is possible to determine if the belt is slipping. Because speed 1 is derived from the head pulley drive it can be considered a reference because it will only normally vary as a result of deliberate action to speed up or slow down the elevator belt. Speed 2 can vary either because of a variation in speed 1 or if the belt begins to slip for any reason. Because we know the ratio of speed 1 to speed 2 then we can check to see the amount of belt slip.

- Example 3:

Speed 1 is 350 PPM. The ratio after calibration is 1.256 therefore speed 2 should be 440 but it is currently 405. This means that the belt is running at 92% of the expected speed (or slipping by 8% (405/440 X 100)). The default alarm level for under-speed is 10% so as yet the slip isn't a problem. If speed 2 was to drop to 390 then the error is 88% of the expected speed (or slipping by 12%) therefore the Watchdog will generate an under speed alarm.

The same principle applies no matter what the elevator speed is providing that the values measured for speed 1 and speed 2 remain within the maximum and minimum speed limits of the Watchdog.

- **14.5.E ACCELERATION MONITORING LEVEL** - When disabled (0), the Watchdog will not monitor speed during the start-up delay. When enabled, the Watchdog will monitor the speed during start-up delay and initiate a stop condition if the system speed is not increasing according to the set acceleration value.

Level settings range from 0 - 9, the default is 5. See below for more information on acceleration monitoring values:

0 - Off, no monitoring will take place.

1 - System speed should reach at least 10% of calibrated speed by 90% of start-up delay.

5 - Default setting, system speed should reach 10% of calibrated speed by 10% of start-up delay, 20% by 20% of start-up delay, etc.

9 - System speed should reach at least 90% of calibrated speed by 10% of start-up delay.

- **14.5.F NUMBER OF STARTS / MINUTE** - This function is used to prevent damage to the motor and motor start circuitry by limiting the number of times in a minute the system can be started. This setting can range from 1 to 10, the default is 3.

When the Watchdog is started and a shutdown fault occurs, a jog delay is introduced. For example, if the “Number of Starts / Minute” is set to 4, then a delay of 15 seconds before restarting would be introduced (60 seconds / 4 starts per minutes = 15 seconds between starts).

The jog countdown is shown under SYSTEM STATUS on the Watchdog’s main screen.

- **14.5.G START UP DELAY [S]** - The delay in seconds before the system starts to fully monitor the system for possible alarm conditions. This setting can range from 1 to 15 seconds, the default is 5. A countdown is shown on the status screen.

This delay allows elevator or conveyor belts to start-up and achieve a correct running state before the general alarm conditions are monitored. The exceptions to this are acceleration monitoring, bearing temperature and plug condition.

If acceleration monitoring is enabled (a value other than 0), and the acceleration speed is outside of the permitted parameters, the Watchdog will stop the elevator or conveyor in accordance with the acceleration monitoring level.

- **14.5.H UNDERSPEED ALARM [%]** - The percentage of underspeed at which the system will cause an alarm. The percentage can be set from 1% to 10%, the default is 10%.

If the measured speed falls below the calibrated speed by this preset percentage, the Watchdog will generate an underspeed alarm condition. If this alarm persists longer than the underspeed stop delay, then the Watchdog will stop the elevator or conveyor.

- **14.5.I SEVERE UNDERSPEED [%]** - The percentage of severe under speed at which the system will shut down. The percentage can be set from 1% to 20%, the default is 20%.

If the measured speed falls below the calibrated speed by this preset percentage, the Watchdog will generate a severe underspeed condition and stop the elevator or conveyor.

- **14.5.J UNDERSPEED ALARM DELAY [S]** - The delay in seconds before the system alarms after a sensor trips. The delay can be set from 0 to 10 seconds, the default is 1. Configuring the delay above zero can help prevent nuisance alarms.

When a sensors trips, a cumulative alarm delay counter starts to count down. If the alarm condition ends before the delay counter reaches zero, the delay counter starts to count back up to the original alarm delay value and the Watchdog will not alarm.

If the system reaches the UNDERSPEED ALARM DELAY time, the alarm relay is de-energized, the ALARM LED on the Watchdog lights up amber, and a warning showing the source of the alarm is displayed in red on the main LCD screen. The alarm event is also logged in the ALARM LOG.

- **14.5.K UNDERSPEED STOP DELAY [S]** - The delay in seconds before the system shuts down. The delay can be set from 0 to 60 seconds, the default is 60.

A cumulative stop delay counter starts to count down simultaneously with the alarm delay. If the alarm condition ends before the delay counter reaches zero, the counter starts to count back up to the original stop delay value and the Watchdog will not stop the system.

After the alarm delay time has elapsed and the alarm has been triggered, the stop delay timer will be displayed on the main LCD. If the Watchdog reaches the UNDERSPEED STOP DELAY time, the stop relay is de-energized, the STOP LED on the Watchdog lights up red, and a warning showing the source of the stop condition is displayed in red on the main LCD screen. The stop event is also logged in the ALARM LOG.

The stop delay does not apply to SEVERE UNDERSPEED[%] conditions. If equipment reaches the set severe percentage, it will stop immediately without any delay.

- **14.5.L OVERSPEED [%]** - The percentage of over speed at which the system will cause an alarm. The percentage can be set from 1% to 10%, the default is 10%.

If the measured speed rises above the calibrated speed by this preset percentage, the Watchdog will generate an overspeed alarm. If this alarm persists longer than the “Overspeed Stop Delay” time, then the Watchdog will stop the elevator or conveyor.

- **14.5.M SEVERE OVERSPEED [%]** - The percentage of severe overspeed at which the system will shut down. The percentage can be set from 1% to 20%, the default is 20%.

If the measured speed rises above the calibrated speed by this preset percentage, the Watchdog will generate a severe overspeed stop condition. This condition results in an immediate stop of the elevator or conveyor.

- **14.5.N OVERSPEED ALARM DELAY [S]** - The delay in seconds before the system alarms after a sensor trips. The delay can be set from 0 to 10 seconds, the default is 1. Configuring the delay above zero can help prevent nuisance alarms.

When a sensors trips, a cumulative alarm delay counter starts to count down. If the alarm condition ends before the delay counter reaches zero, the delay counter starts to count back up to the original alarm delay value and the Watchdog will not alarm.

If the system reaches the OVERSPEED ALARM DELAY time, the alarm relay is de-energized, the ALARM LED on the Watchdog lights up amber, and a warning showing the source of the alarm is displayed in red on the main LCD screen. The alarm event is also logged in the ALARM LOG.

- **14.5.O OVERSPEED STOP DELAY [S]** - The delay in seconds before the system shuts down. The delay can be set from 0 to 60 seconds, the default is 60.

A cumulative stop delay counter starts to count down simultaneously with the alarm delay. If the alarm condition ends before the delay counter reaches zero, the counter starts to count back up to the original stop delay value and the Watchdog will not stop the system.

After the alarm delay time has elapsed and the alarm has been triggered, the stop delay timer will be displayed on the main LCD. If the Watchdog reaches the OVERSPEED STOP DELAY time, the stop relay is de-energized, the STOP LED on the Watchdog lights up red, and a warning showing the source of the stop condition is displayed in red on the main LCD screen. The stop event is also logged in the ALARM LOG.

The stop delay does not apply to SEVERE OVERSPEED[%] conditions. If equipment reaches the set severe percentage, it will stop immediately without any delay.

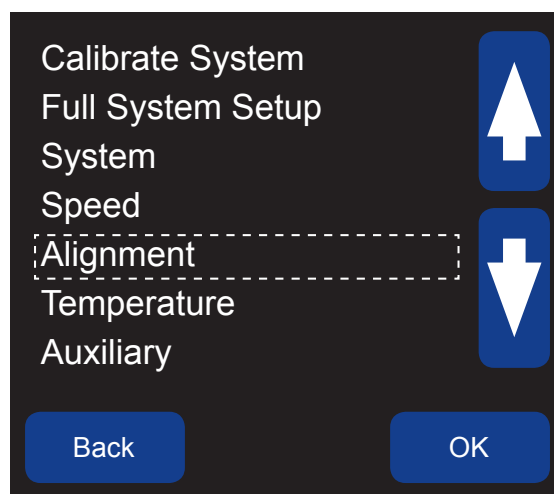

Image 27
Edit Selected Profile - Alignment

14.6 ALIGNMENT (HEAD) -

MENU > SETUP (PASSWORD) > PROFILE > EDIT SELECTED PROFILE > ALIGNMENT

Settings in this menu allow you to monitor alignment at the head and/or tail sections of your equipment. Sensors are installed in pairs (left side - right side) at the head and/or tail sections.

- **14.6.A HEAD SENSOR PAIR** - This section allows you to enable or disable head alignment monitoring. Four options are available:

1. OFF
2. Pulsed
3. Contact (Default Setting)
4. Rub Block

PULSED - Choose this option if using 4B WDA Motion Alignment Sensors, or Touchswitches that are receiving pulses from a P800. The number of pulses detected between the sensors from the right and left sides are compared, if the ratio between the two is less than 66% an alarm condition is generated. The value of 66% is fixed and cannot be altered by the user.

CONTACT (Default) - Choose this option if using 4B Touchswitch sensors (not receiving pulses from a P800). In this mode, the Watchdog looks for a change in signal level representing the belt alignment condition.

- *ON: +24V into the terminal is seen as Normal (no belt misalignment).*
- *OFF: 0V into the terminal is seen as a belt misalignment condition.*

RUB BLOCK - Choose this option if using rub blocks to detect belt misalignment. A rub block is basically a temperature sensor mounted to a special block (usually brass). If the belt rubs constantly against the rub block, heat from friction will cause the rub block's temperature to rise. If the temperature rises above the pre-set limit, a misalignment alarm will be generated. There are a number of settings available for use with the rub block.

- **14.6.B HEAD TRIGGER ALARM** - If CONTACT is selected within the HEAD SENSOR PAIR menu, a trigger alarm must be selected. The default is OFF, meaning that an alarm will be triggered when the contact is off (0V). If ON is selected, the alarm will be triggered when the contact is on (+24V), this option (ON) is only available under FACTORY SETTINGS.
- **14.6.C ABSOLUTE ALARM [DEG]** - If RUB BLOCK is selected within the HEAD SENSOR PAIR menu, an absolute temperature value must be selected. If the measured temperature of the rub block exceeds this value, an alarm is generated. This level setting ranges from 32° to 230° F (1° to 110° C), the default is 140° F (60° C). For PRE ABS ALARM information, refer to section 14.4.B.
- **14.6.D RELATIVE ALARM SOURCE** - If RUB BLOCK is selected within the HEAD SENSOR PAIR menu, a relative alarm source must be selected. Choices are OFF, AMB1, AMB2 or OPPOSITE, the default is OFF.

If either AMB1 or AMB2 are selected, the relative alarm temperature is relative to the ambient temperature. If OPPOSITE is selected, then the relative alarm for each sensor is relative to the opposite sensor's temperature.

- **14.6.E RELATIVE ALARM** - If RUB BLOCK is selected within the HEAD SENSOR PAIR menu and RELATIVE ALARM SOURCE is set to AMB1, AMB2 or OPPOSITE, a relative alarm must be selected.

If the measured temperature of the rub block exceeds the relative temperature value, an alarm is generated. This level setting ranges from 2° to 90° F (1° to 50° C), the default is 30° F (15° C).

- **14.6.F HEAD: RATE OF RISE [DEG/MIN]** - If RUB BLOCK is selected within the HEAD SENSOR PAIR menu and RELATIVE ALARM SOURCE is set to AMB1, AMB2 or OPPOSITE, you can choose to turn the rate of rise ON (default) or OFF. If RELATIVE ALARM SOURCE is set to OFF, you will not be able to choose RATE OF RISE.

If turned ON, this setting monitors the rub block's rate of rise of temperature in degrees per minutes. If a rate of rise is detected equal to or greater than this value, an alarm will be generated and the alarm relay being de-energized. This level setting ranges from 2.0 to 5.0, the default is 3.0.

NOTE

The temperature setting can be set to either Fahrenheit or Celsius, see FULL SYSTEM SETUP.

NOTE

On the HEAD ALIGN INFO screen (Image 28), T#11 is the sensor on the head left and T#12 is head right.

Sensor	Value	Abs	Rel	Trip
T#11	35	140	30	AMB1
T#12	78	140	30	AMB1

Image 28
System Info Screen
Head Align Info - AMB1

Image 28 shows the SYSTEM INFO screen for HEAD ALIGN INFO when AMB1 has been selected.

In the example above, an alarm will be generated when the rub block's temperature is equal to or greater than AMB1 +30°, or if the value exceeds the absolute value of 140°. T#12 is shown in red since it is in an alarm state.

- **14.6.G HEAD ALARM DELAY [S]** - The delay in seconds before the system alarms after a sensor trips. The delay can be set from 0 to 10 seconds, the default is 1. Configuring the delay above zero can help prevent nuisance alarms.

When a sensors trips, a cumulative alarm delay counter starts to count down. If the alarm condition ends before the delay counter reaches zero, the delay counter starts to count back up to the original alarm delay value and the Watchdog will not alarm.

If the system reaches the HEAD ALARM DELAY time, the alarm relay is de-energized, the ALARM LED on the Watchdog lights up amber, and a warning showing the source of the alarm is displayed in red on the main LCD screen. The alarm event is also logged in the ALARM LOG.

- **14.6.H HEAD STOP DELAY [S]** - The delay in seconds before the system shuts down. The delay can be set from 0 to 60 seconds, the default is 60.

A cumulative stop delay counter starts to count down simultaneously with the alarm delay. If the alarm condition ends before the delay counter reaches zero, the counter starts to count back up to the original stop delay value and the Watchdog will not stop the system.

After the alarm delay time has elapsed and the alarm has been triggered, the stop delay timer will be displayed on the main LCD. If the Watchdog reaches the HEAD STOP DELAY time, the stop relay is de-energized, the STOP LED on the Watchdog lights up red, and a warning showing the source of the stop condition is displayed in red on the main LCD screen. The stop event is also logged in the ALARM LOG.

WARNING

When you have completed making changes to the Watchdog profile setup, you will be prompted to save your changes. You must enter YES, or your changes will not go into effect.

14.7 ALIGNMENT (TAIL) -

MENU > SETUP (PASSWORD) > PROFILE > EDIT SELECTED PROFILE > ALIGNMENT

Settings in this menu allow you to monitor alignment at the head and/or tail sections of your equipment. Sensors are installed in pairs (left side - right side) at the head and/or tail sections.

- **14.7.A TAIL SENSOR PAIR** - This section allows you to enable or disable tail alignment monitoring. Four options are available:
 1. OFF
 2. Pulsed
 3. Contact (Default Setting)
 4. Rub Block

PULSED - Choose this option if using either 4B's WDA Motion Alignment Sensors, or Touchswitches that are receiving pulses from a P800. The number of pulses detected between the sensors from the right and left sides are compared, if the difference between the two exceeds 66% an alarm condition is generated. The value of 66% is fixed and cannot be altered by the user.

CONTACT (Default) - Choose this option if using 4B Touchswitch sensors (not receiving pulses from a P800). In this mode, the Watchdog looks for a change in signal level representing the belt alignment condition.

- *ON: +24V into the terminal is seen as normal (no belt misalignment).*
- *OFF: 0V into the terminal is seen as a belt misalignment condition.*

RUB BLOCK - Choose this option if using rub blocks to detect belt misalignment. A rub block is basically a temperature sensor mounted to a special block (usually brass). If the belt rubs constantly against the rub block, heat from friction will cause the rub block's temperature to rise. If the temperature rises above the pre-set limit, a misalignment alarm will be generated. There are a number of settings available for use with the rub block.

- **14.7.B TAIL TRIGGER ALARM** - If CONTACT is selected within the TAIL SENSOR PAIR menu, a trigger alarm must be selected. The default is OFF, meaning that an alarm will be triggered when the contact is off (0V). If ON is selected, the alarm will be triggered when the contact is on (+24V), this option (ON) is only available under FACTORY SETTINGS.
- **14.7.C ABSOLUTE ALARM [DEG]** - If RUB BLOCK is selected within the TAIL SENSOR PAIR menu, a absolute temperature value must be selected.

If the measured temperature of the rub block exceeds this value, an alarm is generated. This level setting ranges from 32° to 230° F (1° to 110° C), the default is 140° F (60° C).

- **14.7.D RELATIVE ALARM SOURCE** - If RUB BLOCK is selected within the TAIL SENSOR PAIR menu, a relative alarm source must be selected. Choices are OFF, AMB1, AMB2 or OPPOSITE, the default is OFF.

If either AMB1 or AMB2 are selected, the relative alarm temperature is relative to the ambient temperature. If OPPOSITE is selected, then the relative alarm for each sensor is relative to the opposite sensor's temperature.

- **14.7.E RELATIVE ALARM** - If RUB BLOCK is selected within the TAIL SENSOR PAIR menu and RELATIVE ALARM SOURCE is set to AMB1, AMB2 or OPPOSITE, a relative alarm must be selected.

If the measured temperature of the rub block exceeds the relative temperature value, an alarm is generated. This level setting ranges from 2° to 90° F (1° to 50° C), the default is 30° F (15° C).

- **14.7.F TAIL: RATE OF RISE [DEG/MIN]** - If RUB BLOCK is selected within the TAIL SENSOR PAIR menu and RELATIVE ALARM SOURCE is set to AMB1, AMB2 or OPPOSITE, you can choose to turn the rate of rise ON (default) or OFF. If RELATIVE ALARM SOURCE is set to OFF, you will not be able to choose RATE OF RISE.

If turned ON, this setting monitors the rub block's rate of rise of temperature in degrees per minutes. If a rate of rise is detected equal to or greater than this value, an alarm will be generated and the alarm relay being de-energized. This level setting ranges from 2.0 to 5.0, the default is 3.0.

NOTE

The temperature setting can be set to either Fahrenheit or Celsius, see FULL SYSTEM SETUP.

NOTE

On the TAIL ALIGN INFO screen (Image 29), T#9 is the sensor on the tail left and T#10 is tail right.

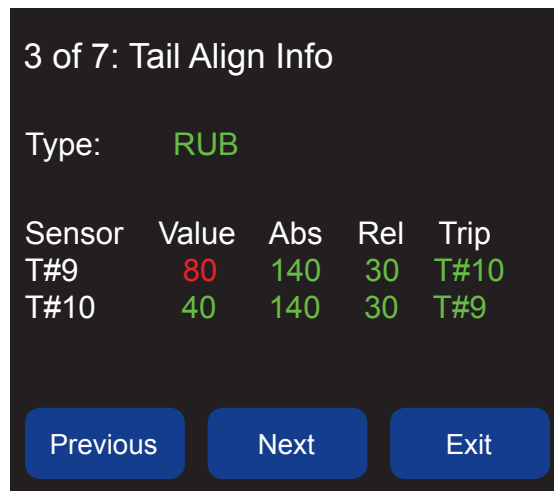

Image 29
System Info Screen
Tail Align Info - Opposite

Image 29 shows the SYSTEM INFO screen for TAIL ALGIN INFO when OPPOSITE has been selected, meaning that the relative alarm temperature for sensor T#9 is T#10 and vice versa. For instance, an alarm will be generated when the actual temperature of T#9 exceeds the temperature of T#10 by +30°. T#9 is shown in red since it is in an alarm state.

- **14.7.G TAIL ALARM DELAY [S]** - The delay in seconds before the system alarms after a sensor trips. The delay can be set from 0 to 10 seconds, the default is 1. Configuring the delay above zero can help prevent nuisance alarms.

When a sensors trips, a cumulative alarm delay counter starts to count down. If the alarm condition ends before the delay counter reaches zero, the delay counter starts to count back up to the original alarm delay value and the Watchdog will not alarm.

If the system reaches the TAIL ALARM DELAY time, the alarm relay is de-energized, the ALARM LED on the Watchdog lights up amber, and a warning showing the source of the alarm is displayed in red on the main LCD screen. The alarm event is also logged in the ALARM LOG.

- **14.7.H TAIL STOP DELAY [S]** - The delay in seconds before the system shuts down. The delay can be set from 0 to 60 seconds, the default is 60.

A cumulative stop delay counter starts to count down simultaneously with the alarm delay. If the alarm condition ends before the delay counter reaches zero, the counter starts to count back up to the original stop delay value and the Watchdog will not stop the system.

After the alarm delay time has elapsed and the alarm has been triggered, the stop delay timer will be displayed on the main LCD. If the Watchdog reaches the TAIL STOP DELAY time, the stop relay is de-energized, the STOP LED on the Watchdog lights up red, and a warning showing the source of the stop condition is displayed in red on the main LCD screen. The stop event is also logged in the ALARM LOG.

14.8 TEMPERATURE -

MENU > SETUP (PASSWORD) > PROFILE > EDIT SELECTED PROFILE > TEMPERATURE

The Watchdog can monitor up to 8 NTC type temperature sensors (standard) or up to 20 with additional NTC expansion boards. In the Watchdog system, 6 of these sensors are referred to as hot bearing sensor 1 (HBS1) through hot bearing sensor 6 (HBS6). The other 2 sensors are referred to as ambient sensor 1 (AMB1) and ambient sensor 2 (AMB2). Each sensor can be switched ON or OFF as required and they can be used in any combination.

If NTC expansion boards have been installed (see 14.4.E & 14.4.F), an expanded menu will be available to configure up to 12 additional temperature inputs.

- If expansion board 1 (EXP1) has been installed, then HBS7 - HBS12 will be available.
- If expansion board 2 (EXP2) has been installed, then HBS13 - HBS18 will be available.

NOTE

While originally developed for displaying hot bearing sensors (HBS), menus displaying HBS can refer to any NTC type temperature sensor such as those used with brass rub blocks (ADB Series) or surface temperature sensors (WDB7 Series).

Since the menus are the same for each NTC sensor, HBS1 will be used as a template for all HBS sensors in this manual.

- **14.8.A HBS1** - Choices are OFF or NTC. Select OFF to disable the sensor or NTC to enable the sensor. The default setting for HBS1 through HBS4 is NTC, while the default for HBS5 and HBS6 is OFF.
- **14.8.B HBS1: ABSOLUTE ALARM [DEG]** - This is the absolute maximum temperature at which the Watchdog will generate an alarm. If an alarm is generated, the effected bearing sensor icon will change from green to red on the main LCD screen. The alarm condition is also logged in the ALARM LOG. This level setting ranges from 32° to 230° F (1° to 110° C), the default is 140° F (60° C). For PRE ABS ALARM information, refer to section 14.4.B.
- **14.8.C HBS1: RELATIVE ALARM SOURCE** - Allows you to select a relative alarm source. Choices are OFF, AMB1 or AMB2, the default is OFF. This option creates a relationship between two different temperature sensors. When using the setup screen on the Watchdog, HBS1 - HBS6 can only be related to ambient sensor 1 (AMB1) or ambient sensor 2 (AMB2). By using the advanced setup features within the WDC4 Configurator Software, any hot bearing sensor can alarm relative to any other.

For example - If you use the configuration software, you can set a RELATIVE ALARM SOURCE between HBS1 and HBS4. Once the relationship is set you can specify a RELATIVE ALARM value. This value is used to set the alarm level of one temperature to another. If HBS1 is related to HBS4 and the RELATIVE ALARM value is set to 15° F, then a temperature alarm would be generated when the temperature of HBS1 exceeded the temperature of HBS4 by 15° F.

When you select a RELATIVE ALARM SOURCE, the appropriate sensor is automatically enabled. Setting HBS4 as the RELATIVE ALARM SOURCE for HBS1 will automatically enable HBS4. When a sensor is automatically enabled, the default values are used for that sensor, so make sure that the settings are appropriate for your intended use.

- **14.8.D HBS1: RELATIVE ALARM [DEG]** - If AMB1 OR AMB2 is selected within the RELATIVE ALARM SOURCE menu, a relative temperature value must be selected.

If the measured temperature of the bearing sensor exceeds the relative temperature value, an alarm is generated. This level setting ranges from 2° to 90° F (1° to 50° C), the default is 30° F (15° C).

- **14.8.E HBS1: RATE OF RISE [DEG/MIN]** - You can choose to turn the rate of rise ON (default) or OFF. If turned OFF, the rate of rise is ignored and no alarm will be generated.

If turned ON, this setting monitors the rate of rise of the bearing sensor temperatures. It is designed to detect when temperature rises are in excess of what might be considered normal. If the sensor temperature rises more than 3 degrees (default) per minute, then a RATE OF RISE alarm will be generated. If an alarm is detected, the alarm relay will be de-energized until the rate of rise drops below the set target. The process of monitoring the rate of rise can be delayed at start-up by setting the RATE OF RISE START UP DELAY in the SYSTEM SETTINGS menu. This level setting ranges from 2.0 to 5.0, the default is 3.0.

- **14.8.F HBS1 ALARM DELAY [S]** - The delay in seconds before the system alarms after a sensor trips. The delay can be set from 0 to 10 seconds, the default is 1. Configuring the delay above zero can help prevent nuisance alarms.

When a sensors trips, a cumulative alarm delay counter starts to count down. If the alarm condition ends before the delay counter reaches zero, the delay counter starts to count back up to the original alarm delay value and the Watchdog will not alarm.

If the system reaches the ALARM DELAY time, the alarm relay is de-energized, the ALARM LED on the Watchdog lights up amber, and a warning showing the source of the alarm is displayed in red on the main LCD screen. The alarm event is also logged in the ALARM LOG.

- **14.8.G HBS1 STOP DELAY [S]** - The delay in seconds before the system shuts down. The delay can be set from 0 to 60 seconds, the default is 60.

A cumulative stop delay counter starts to count down simultaneously with the alarm delay. If the alarm condition ends before the delay counter reaches zero, the counter starts to count back up to the original stop delay value and the Watchdog will not stop the system.

After the alarm delay time has elapsed and the alarm has been triggered, the stop delay timer will be displayed on the main LCD. If the Watchdog reaches the STOP DELAY time, the stop relay is de-energized, the STOP LED on the Watchdog lights up red, and a warning showing the source of the stop condition is displayed in red on the main LCD screen. The stop event is also logged in the ALARM LOG.

Since the menus are the same for both AMB1 and AMB2, AMB1 will be used as a template in this manual.

- **14.8.H AMB1** - Up to 2 ambient temperature sensors may be used with the Watchdog. These can be used to monitor the temperature of additional bearings, motors or gearboxes. These sensors are referred to as AMB1 and AMB2. Each sensor can be switched OFF (default) or NTC as required and they can be used in any combination.

- **14.8.I AMB1: ABSOLUTE ALARM [DEG]** - This is the absolute maximum temperature at which the Watchdog will generate an alarm. The appropriate ambient sensor icon will change from green to red on the main LCD screen, and the alarm condition will be logged in the ALARM LOG. This level setting ranges from 32° to 230° F (1° to 110° C), the default is 140° F (60° C). For PRE ABS ALARM information, refer to section 14.4.B.

- **14.8.J AMB1: RATE OF RISE [DEG/MIN]** - You can choose to turn the rate of rise ON (default) or OFF. If turned OFF, the rate of rise is ignored and no alarm will be generated.

If turned ON, this setting monitors the rate of rise of the ambient sensor temperatures. It is designed to detect when temperature rises are in excess of what might be considered normal. If the sensor temperature rises more than 3 degrees (default) per minute, then a RATE OF RISE alarm will be generated. If an alarm is detected, the alarm relay will be de-energized until the rate of rise drops below the set target. The process of monitoring the rate of rise can be delayed at start-up by setting the RATE OF RISE START UP DELAY in the SYSTEM SETTINGS menu. This level setting ranges from 2.0 to 5.0, the default is 3.0.

- **14.8.K AMB1: ALARM DELAY [S]** - The delay in seconds before the system alarms after a sensor trips. The delay can be set from 0 to 10 seconds, the default is 1. Configuring the delay above zero can help prevent nuisance alarms.

When a sensors trips, a cumulative alarm delay counter starts to count down. If the alarm condition ends before the delay counter reaches zero, the delay counter starts to count back up to the original alarm delay value and the Watchdog will not alarm.

If the system reaches the ALARM DELAY time, the alarm relay is de-energized, the ALARM LED on the Watchdog lights up amber, and a warning showing the source of the alarm is displayed in red on the main LCD screen. The alarm event is also logged in the ALARM LOG.

- **14.8.L AMB1: STOP DELAY [S]** - The delay in seconds before the system shuts down. The delay can be set from 0 to 60 seconds, the default is 60.

A cumulative stop delay counter starts to count down simultaneously with the alarm delay. If the alarm condition ends before the delay counter reaches zero, the counter starts to count back up to the original stop delay value and the Watchdog will not stop the system.

After the alarm delay time has elapsed and the alarm has been triggered, the stop delay timer will be displayed on the main LCD. If the Watchdog reaches the STOP DELAY time, the stop relay is de-energized, the STOP LED on the Watchdog lights up red, and a warning showing the source of the stop condition is displayed in red on the main LCD screen. The stop event is also logged in the ALARM LOG.

14.9 AUXILIARY -

MENU > SETUP (PASSWORD) > PROFILE > EDIT SELECTED PROFILE > AUXILIARY

The Watchdog is capable of monitoring for plug conditions (PLUG) and pulley misalignment (PULLEY). To enable these functions, sensors must be installed and turned on within the AUXILIARY menu.

- **14.9.A PLUG ENABLED** - Choices are YES or NO (default). A plug or choke sensor is usually used for blocked chute detection. A Binswitch Elite is most commonly used, however an Auto-Set™ flush probe can also be installed depending on the application.

When a plug sensor is installed and PLUG ENABLED is YES, the Watchdog looks for a change in signal level representing the plug condition.

- ON: +24V into the terminal is seen as normal (no plug detected).
- OFF: 0V into the terminal is seen as blockage (plug) detected condition.

- **14.9.B PLUG TRIGGER ALARM WHEN** - Choices are ON or OFF (default). Allows you to choose to trigger an alarm when the sensor contact is on, or trigger an alarm when the sensor contact is off. The default is OFF, in order to switch this setting to ON, you must go to the FACTORY SETTINGS menu.

- **14.9.C PLUG ALARM DELAY [S]** - The delay in seconds before the system alarms after a sensor trips. The delay can be set from 0 to 10 seconds, the default is 1. Configuring the delay above zero can help prevent nuisance alarms.

When a sensors trips, a cumulative alarm delay counter starts to count down. If the alarm condition ends before the delay counter reaches zero, the delay counter starts to count back up to the original alarm delay value and the Watchdog will not alarm.

If the system reaches the ALARM DELAY time, the alarm relay is de-energized, the ALARM LED on the Watchdog lights up amber, and a warning showing the source of the alarm is displayed in red on the main LCD screen. The alarm event is also logged in the ALARM LOG.

- **14.9.D PLUG STOP DELAY [S]** - The delay in seconds before the system shuts down. The delay can be set from 0 to 60 seconds, the default is 3.

A cumulative stop delay counter starts to count down simultaneously with the alarm delay. If the alarm condition ends before the delay counter reaches zero, the counter starts to count back up to the original stop delay value and the Watchdog will not stop the system.

After the alarm delay time has elapsed and the alarm has been triggered, the stop delay timer will be displayed on the main LCD. If the Watchdog reaches the STOP DELAY time, the stop relay is de-energized, the STOP LED on the Watchdog lights up red, and a warning showing the source of the stop condition is displayed in red on the main LCD screen. The stop event is also logged in the ALARM LOG.

- **14.9.E PULLEY ENABLED** - Choices are YES or NO (default). The pulley sensor is usually used to detect if the drive pulley has moved position (misaligned). Typically a Touchswitch contact sensor would be used for application.

When a pulley sensor is installed and PULLEY ENABLED is YES, the Watchdog looks for a change in signal level representing the misaligned pulley condition.

- *ON: +24V into the terminal is seen as normal (no pulley movement).*
- *OFF: 0V into the terminal is seen when pulley movement has been detected.*

- **14.9.F PULLEY TRIGGER ALARM WHEN** - Choices are ON or OFF (default). Allows you to choose to trigger an alarm when the sensor contact is on, or trigger an alarm when the sensor contact is off. The default is OFF, in order to switch this setting to ON, you must go to the FACTORY SETTINGS menu.

- **14.9.G PULLEY ALARM DELAY [S]** - The delay in seconds before the system alarms after a sensor trips. The delay can be set from 0 to 10 seconds, the default is 1. Configuring the delay above zero can help prevent nuisance alarms.

When a sensors trips, a cumulative alarm delay counter starts to count down. If the alarm condition ends before the delay counter reaches zero, the delay counter starts to count back up to the original alarm delay value and the Watchdog will not alarm.

If the system reaches the ALARM DELAY time, the alarm relay is de-energized, the ALARM LED on the Watchdog lights up amber, and a warning showing the source of the alarm is displayed in red on the main LCD screen. The alarm event is also logged in the ALARM LOG.

- **14.9.H PULLEY STOP DELAY [S]** - The delay in seconds before the system shuts down. The delay can be set from 0 to 60 seconds, the default is 5.

A cumulative stop delay counter starts to count down simultaneously with the alarm delay. If the alarm condition ends before the delay counter reaches zero, the counter starts to count back up to the original stop delay value and the Watchdog will not stop the system.

After the alarm delay time has elapsed and the alarm has been triggered, the stop delay timer will be displayed on the main LCD. If the Watchdog reaches the STOP DELAY time, the stop relay is de-energized, the STOP LED on the Watchdog lights up red, and a warning showing the source of the stop condition is displayed in red on the main LCD screen. The stop event is also logged in the ALARM LOG.

WARNING

When you have completed making changes to the Watchdog profile setup, you will be prompted to save your changes. You must enter YES, or your changes will not go into effect.

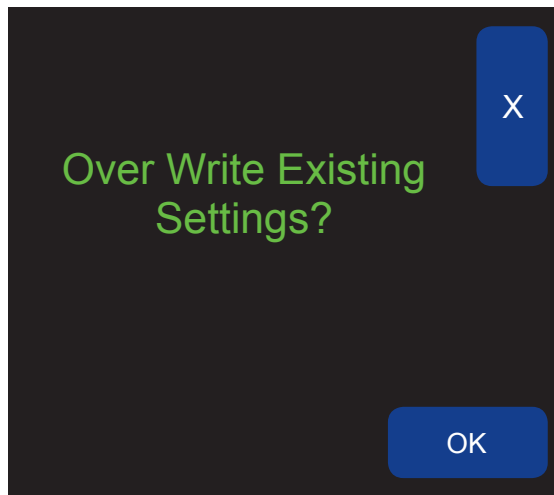

Image 30
Profile - Restore Defaults

14.10 RESTORE DEFAULTS -

MENU > SETUP (PASSWORD) > PROFILE > RESTORE DEFAULTS (PASSWORD)

All settings in the Watchdog can be restored to the factory default settings as described in Appendix B. Before allowing the settings to be reset, the user is prompted to enter the engineering password again and a final confirmation screen to confirm the action is displayed (Image 30). The menu choices are: X (No) terminate without taking action, or OK (Yes), restore the factory defaults.

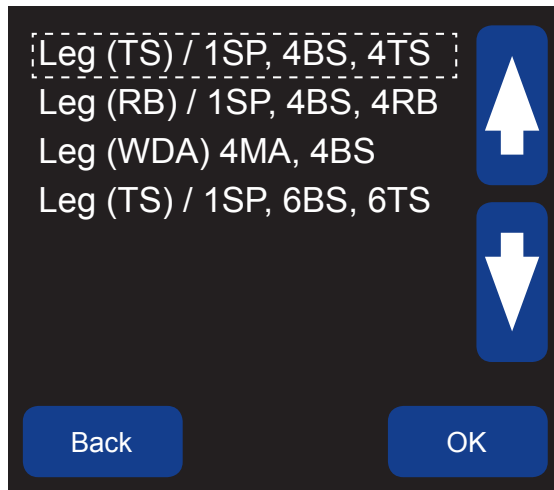

Image 31
Profile - Select New Profile

14.11 SELECT NEW PROFILE -

MENU > SETUP (PASSWORD) > PROFILE > SELECT NEW PROFILE

To help make the set up process easier for bucket elevator legs, four pre-set program profiles are available to choose from (Image 31). All four profiles are also listed in the WIRING DIAGRAMS section.

- | | |
|--|---|
| <p>1. LEG (TS) / 1 SP, 4BS, 4TS</p> <ul style="list-style-type: none"> • 1 Speed Sensor • 4 Bearing Temperature Sensors • 4 Touchswitch Sensors (Alignment) | <p>3. LEG (WDA) 4MA, 4BS</p> <ul style="list-style-type: none"> • 4 Motion Alignment Sensors • 4 Bearing Temperature Sensors |
| <p>2. LEG (RB) / 1SP, 4BS, 4RB</p> <ul style="list-style-type: none"> • 1 Speed Sensor • 4 Bearing Temperature Sensors • 4 Rub Block Sensors (Alignment) | <p>4. LEG (TS) / 1SP, 6BS, 6TS</p> <ul style="list-style-type: none"> • 1 Speed Sensor • 6 Bearing Temperature Sensors • 6 Touchswitch Sensors (Alignment) |

NOTE

All pre-set program profiles default to the factory settings. To modify settings from the factory defaults, go to the EDIT SELECTED PROFILE menu.

15. TEST

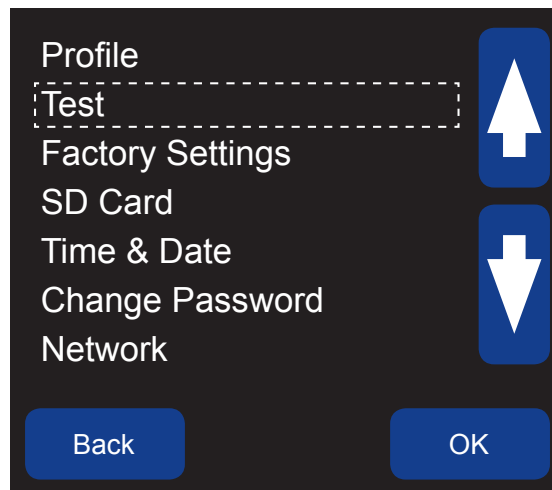

Image 32
Setup Menu - Test

15. TEST -

MENU > SETUP (PASSWORD) > TEST

A number of test functions are available to simulate various fault conditions to validate the functionality of the alarm and stop relays (Image 32). The testing function is not designed to test the sensors on the equipment, it allows you to insure that your control wiring, PLC or HazardMon.com connectivity are functioning. None of the tests will function if the Watchdog is in an alarm condition, or if the system has not been calibrated. Testing can be run for the following: ALARM RELAY, ALIGNMENT, OVER SPEED, UNDER SPEED and HOT BEARING SENSOR.

NOTE

Only the ALARM RELAY test can be started while the equipment is running. All of the other tests require the equipment to be stopped prior to testing.

- **15.1 ALARM RELAY** - Toggles the alarm relay 5 times at a rate of once per second. The display prompts you to “Press OK to Start the Test and Then Start the Elevator”. If the elevator is already running, the test will begin immediately. If the elevator is stopped, the test will begin the next time the elevator is started. When testing begins, “ALARM TEST” will appear under SYSTEM STATUS on the main LCD screen. The elevator will remain running after the test is concluded.
- **15.2 ALIGNMENT** - Simulates an alignment fault condition by introducing a head alignment fault. The values used for alarm and stop delays will be the current settings. The display prompts you to “Press OK to Start the Test and Then Start the Elevator”. The test will begin the next time the elevator is started. When testing begins, “ALIGN. TEST” will appear under SYSTEM STATUS on the main LCD screen. The elevator will be in the stopped condition after the test is concluded. If the alarm and stop delays are excessive, then it will take a long time to perform the test.
- **15.3 OVER SPEED** - Simulates an over speed fault condition by simulating an increase in speed by 15%, introducing an over-speed condition. The values used for alarm and stop delays will be the current settings. The display prompts you to “Press OK to Start the Test and Then Start the Elevator”. The test will begin the next time the elevator is started. When testing begins, “O/S TEST” will appear under SYSTEM STATUS on the main LCD screen. The elevator will be in the stopped condition after the test is concluded. If the alarm and stop delays are excessive, then it will take a long time to perform the test.

- **15.4 UNDER SPEED** - Simulates an under speed fault condition by simulating a decrease in speed by 15%, introducing an under speed condition. The values used for alarm and stop delays will be the current settings. The display prompts you to “Press OK to Start the Test and Then Start the Elevator”. The test will begin the next time the elevator is started. When testing begins, “U/S TEST” will appear under SYSTEM STATUS on the main LCD screen. The elevator will be in the stopped condition after the test is concluded. If the alarm and stop delays are excessive, then it will take a long time to perform the test.
- **15.5 HOT BEARING SENSOR** - Simulates a hot bearing sensor exceeding the trip value. The test is always on HBS1. If HBS1 is not enabled, the firmware will enable it for the duration of the test and then switch it back off when the testing has been completed. The values used for alarm and stop delays will be the current settings. The display prompts you to “Press OK to Start the Test and Then Start the Elevator”. The test will begin the next time the elevator is started. When testing begins, “HBS TEST” will appear under SYSTEM STATUS on the main LCD screen. The elevator will be in the stopped condition after the test is concluded. If the alarm and stop delays are excessive, then it will take a long time to perform the test.

16. FACTORY SETTINGS

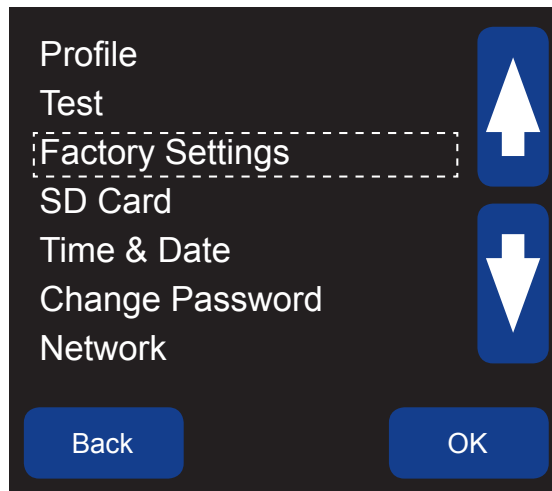

Image 33
Factory Settings Menu

16. FACTORY SETTINGS -

MENU > SETUP (PASSWORD) > FACTORY SETTINGS (PASSWORD)

The changes that can be made through the PROFILE menu have been deliberately limited to safe values. The FACTORY SETTINGS option allows a wider range of adjustments to be made, and should be used with extreme caution.

The FACTORY SETTINGS menu can only be accessed by calling 4B technical support and getting an administrator password. When this menu is selected, the screen will display a 4 digit number generated by the Watchdog (Image 33). You must give this code to a 4B technical support representative, and after they verify that the changes you intend to make will leave the Watchdog in a safe working condition will in return give you a 4 digit administrator password. The password expires after one use.

Once saved, any changes will become the new set limits and you will automatically exit the FACTORY SETTINGS menu and be taken back to the PROFILE menu. Since only one setting can be changed per access within FACTORY SETTINGS, you may need to contact 4B on more than one occasion. This may seem to be a nuisance, but the intention is to reduce the risk that some incorrect adjustment may cause the Watchdog to function in an undesirable and potentially unsafe way.

DANGER

Improper changes made to the Watchdog’s FACTORY SETTINGS menus can be potentially unsafe. Always consult with 4B technical support to confirm any change prior to implementation.

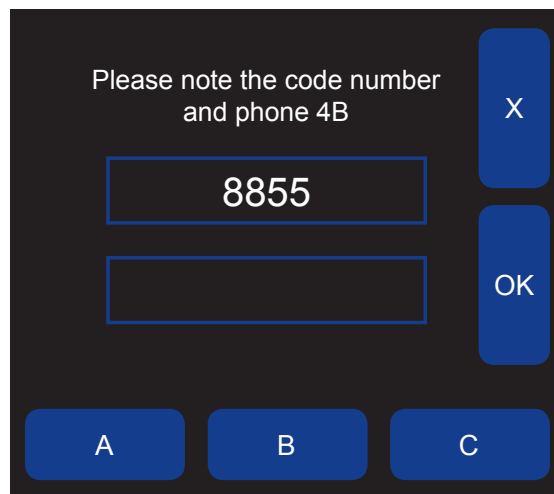

Image 34
Factory Settings -
Password Screen

16.1 EDIT SELECTED PROFILE -

MENU > SETUP (PASSWORD) > FACTORY SETTINGS (PASSWORD) > EDIT SELECTED PROFILE

The EDIT SELECTED PROFILE menu within FACTORY SETTINGS is almost an exact duplicate of the menus found under PROFILE. FACTORY SETTINGS allow for a wider range of system adjustments which should only be changed by advanced users. 4B recommends using the standard settings found within the PROFILE menu. Refer back PROFILE for more details.

16.2 RESTORE DEFAULTS -

MENU > SETUP (PASSWORD) > FACTORY SETTINGS (PASSWORD) > RESTORE DEFAULTS

The RESTORE DEFAULTS menu within FACTORY SETTINGS is an exact duplicate of the same menu found under PROFILE. Refer back PROFILE for more details.

16.3 SELECT NEW PROFILE -

MENU > SETUP (PASSWORD) > FACTORY SETTINGS (PASSWORD) > SELECT NEW PROFILE

The SELECT NEW PROFILE menu within FACTORY SETTINGS is an exact duplicate of the same menu found under PROFILE. Refer back PROFILE for more details.

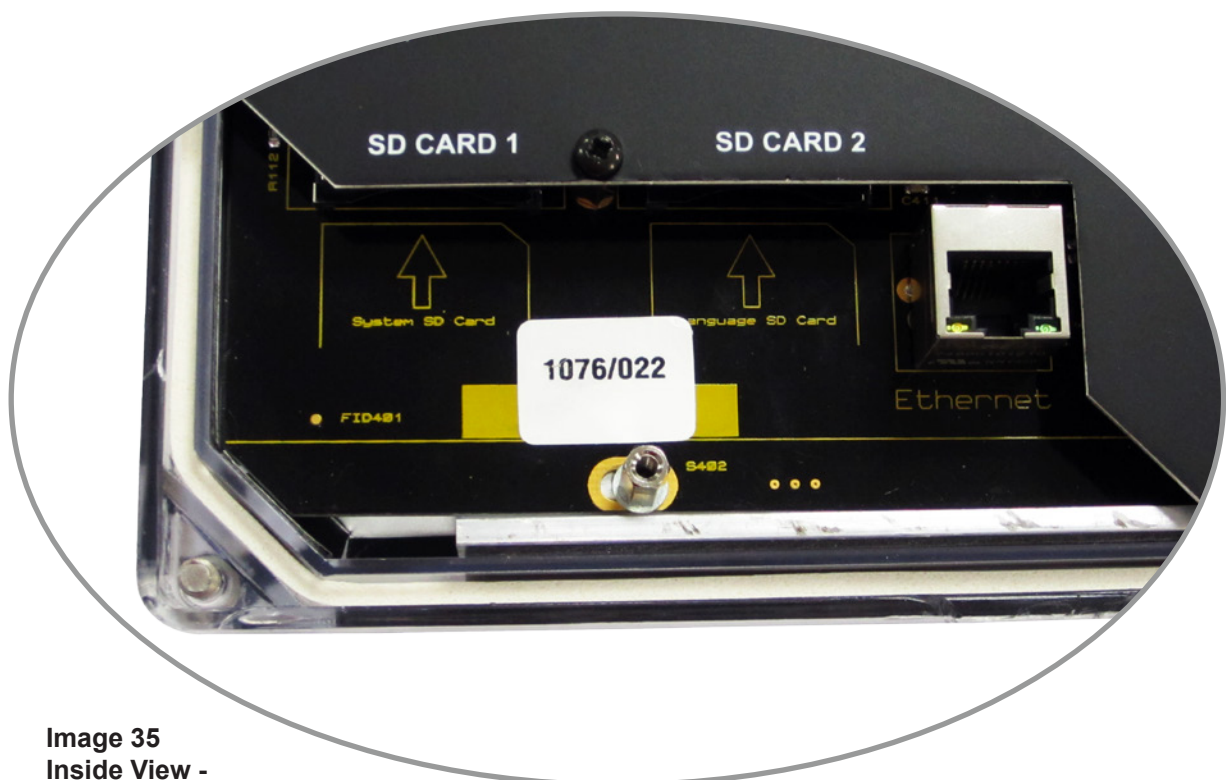

Image 35
Inside View -
SD Cards (2) & Ethernet Port

17. SD CARD

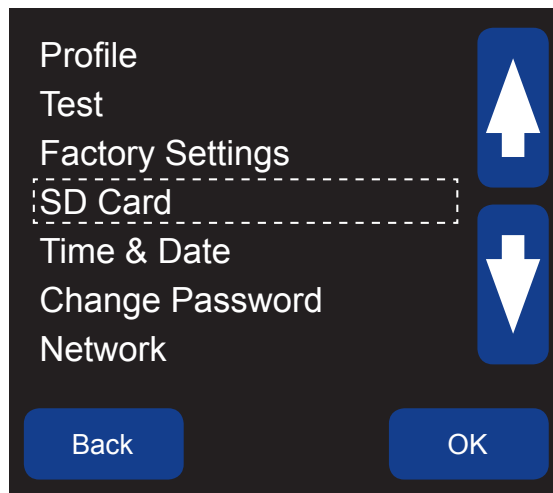

Image 36
Setup Menu - SD Card

17. SD CARD -

MENU > SETUP (PASSWORD) > SD CARD

All of the settings in the Watchdog can be saved to and loaded from an SD card inserted into the System Card / SD Card 1 slot (Image 35) inside the control unit. The setup file will have an extension of .wd4. An SD card will be required if you are using the WDC4 Configurator software to setup the Watchdog (Appendix C).

The SD CARD menu has two options -

- **LOAD FILE .WD4** - If loading the file is successful an entry will be made in the ALARM LOG “Settings<-SD” (indicating that data was loaded from the SD card). Along with the date and time the load was performed. If the SD card is missing or an error occurred it will be recorded in the alarm log as “SD No Media”. Before loading the settings you will be given a warning stating that all your current settings will be overwritten. You can then continue with the load or cancel.
- **SAVE FILE .WD4** - Any existing file with the .wd4 extension will be destroyed and replaced. If saving the file is successful an entry will be made in the ALARM LOG “Settings>-SD” (indicating that data was saved to the SD card). Along with the date and time the save was performed. If the SD card is missing or an error occurred it will be recorded in the alarm log as “SD No Media”.

If an SD card is present, a file named WDC4.csv will be created. This file will contain all the logging information regarding the status of the Watchdog. Any run / stop request and alarm / stop conditions are logged. If a WDC4.csv file already exists on the SD card, the data will be appended to the existing data in the file.

If the file size of WDC4.csv exceeds 10 MB, a warning will be reported in the ALARM LOG. If using a program such as Microsoft Excel, the file size is important since versions before 2008 can have issues importing large file sizes.

WARNING

Power down the Watchdog before inserting or removing the SD card from either the SD CARD 1 or SD CARD 2 slots to prevent system errors.

18. TIME & DATE

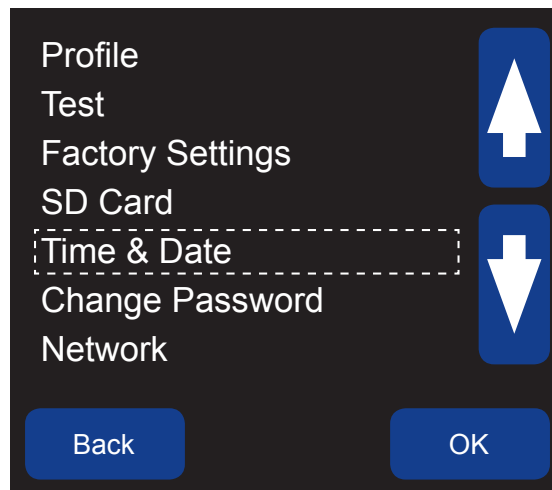

Image 37
Setup Menu - Time & Date

18. TIME & DATE -

MENU > SETUP (PASSWORD) > TIME & DATE

The time can be set by pressing the HRS, MIN or SEC keys at the bottom of the screen. One press will increment the chosen value by one count. When you have completed the time settings press the “OK” button to save the changes. Pressing the “X” button will exit the setting mode without saving the changes.

The date can be set by pressing the DAY, MONTH or YEAR keys at the bottom of the screen. One press will increment the chosen value by one count. When you have completed the date settings press the “OK” button to save the changes. Pressing the “X” button will exit the setting mode without saving the changes.

19. CHANGE PASSWORD

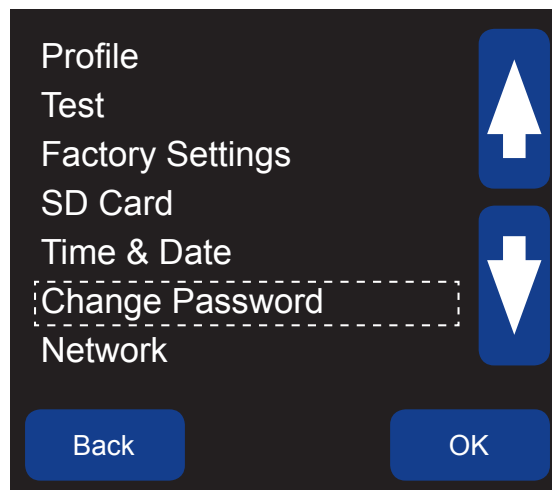

Image 38
Setup Menu - Change Password

19. CHANGE PASSWORD -

MENU > SETUP (PASSWORD) > CHANGE PASSWORD

In order to make any system changes to the Watchdog, an engineering password is required. This is to ensure that only authorized people can change important settings that may lead to inappropriate operation of the Watchdog. The default engineering password set at the factory is BBBB.

You can change the password from the factory setting within this menu by choosing CHANGE PASSWORD. The password is from 1 to 8 characters long, and can be any combination of the letters A, B and C. If you change the password from the factory default, make a note of your new password because if you lose it you will not be able to make changes to the Watchdog. If you do lose the password, contact 4B technical support.

20. NETWORK

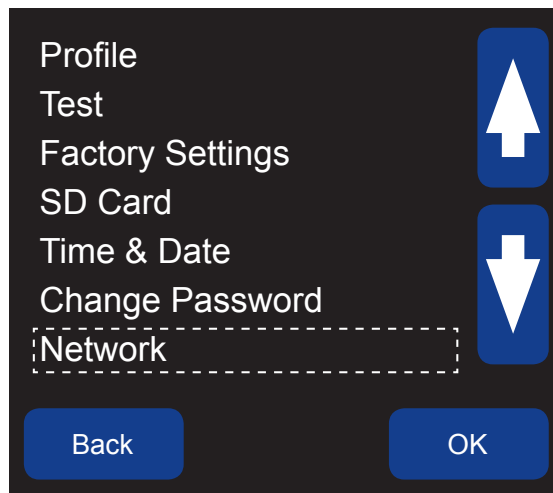

Image 39
Setup Menu - Network

20. NETWORK -

MENU > SETUP (PASSWORD) > NETWORK

- **Hazardmon** - The Watchdog Super Elite can be integrated into HazardMon.com®, which is a secure cloud based hazard monitoring solution providing status notifications and data logging for bucket elevators and conveyors. Live system status, graphs and historical data can be viewed on any web-enabled device (smartphone, tablet PC, desktop or laptop computer). Emails can be sent to notify users whenever a change in the system's health is detected. An automated maintenance feature allows site operators to verify that all sensors on the system are operational and working correctly.

You can choose to turn Hazardmon ON (default) or OFF. In order to establish a connection to HazardMon.com, you will need to configure a network connection. Contact 4B technical support prior to turning on this feature, 4B will work with your internal IT department to properly configure the required network settings.

- **DHCP (Dynamic Host Configuration Protocol)** - A network protocol that enables a server to automatically assign an IP address and other related configuration information to a computer from a defined range of numbers configured for a given network.

You can choose to turn DHCP ON or OFF (default). If you choose ON, the network settings will be automatic. If you choose OFF, you will need to manually enter all of the network settings.

- **Ethernet IP** - Is the numerical address of a device on the local computer network.
- **Gateway** - Is a node (router) on a network that serves as an access point to give entry into different networks to send email, view web pages, etc.
- **Subnet Mask** - The subnet mask is a network generated number that identifies the network to which an IP address belongs. This allows your computer to determine if it is speaking with another computer within the same network or on a remote network and dictates how your computer communicates with other computers it encounters. Subnetting is used to improve network security and performance.
- **DNS1** - A domain name server (DNS) is the Internet's equivalent of a phone book. They maintain a directory of domain names (URL) and translate them to Internet Protocol (IP) addresses. DNS is required for translation of hostnames to IP addresses and vice versa; this translation is what makes sending and receiving email, browsing the web, and numerous other network services work.
- **DNS2** - A backup server to DNS1 just in case it were to become unavailable for whatever reason.

21. TROUBLESHOOTING GUIDE

For details on specific alarms, go to the ALARM LOG and choose MORE INFO. This will provide you with details on the alarm such as: date, time, entry type, entry source, condition and data that is alarm dependent by type.



Head & Tail Alignment



Bearing Temperature



Pulley Alignment



Plug Sensor



Ambient Temperature

LCD Icon	LCD Status	FAULT	CAUSE / REMEDY
	Alarm: HBS(1) ABS (Could be HBS 1-6)	Hot bearing sensor 1 trip exceeded	Excessive temperature, check bearing
	Alarm: HBS(1) O/C (Could be HBS 1-6)	Hot bearing sensor 1 open circuit	Faulty sensor or wiring
	Alarm: HBS(1) S/C (Could be HBS 1-6)	Hot bearing sensor 1 short circuit	Faulty sensor or wiring
	Alarm: AMB(1) (Could Be AMB1 or 2)	Ambient sensor trip exceeded	Excessive temperature, check bearing
	Alarm: PLUG	Plug sensor has been activated	Blocked chute
	Alarm: PULLEY	Pulley sensor has been activated	Pulley has misaligned, repair before running.
	Alarm: MIS HEAD	Head misalignment condition	Belt slippage, check belt tension
	Alarm: MIS TAIL	Tail misalignment condition	Belt slippage, check belt tension
	Shutdown: Jog Event or Jog Delay	Too many equipment start attempts during a short period of time	Jog delay timer has activated to keep motor starter from overheating. Wait for jog delay timer to expire before restarting equipment
	Shutdown: SPEED SOS	Severe overspeed condition	Equipment is running at excessively high speeds, check belt tension and calibration
	Shutdown: SPEED OS	Overspeed condition	Equipment is running faster than the set limit, check belt tension and calibration
	Shutdown: SPEED SUS	Severe underspeed condition	Equipment is running at excessively low speeds, check belt tension and load
	Shutdown: SPEED US	Underspeed condition	Equipment is running slower than the set limit, check belt tension and load

22. APPENDIX A - MENU TREE

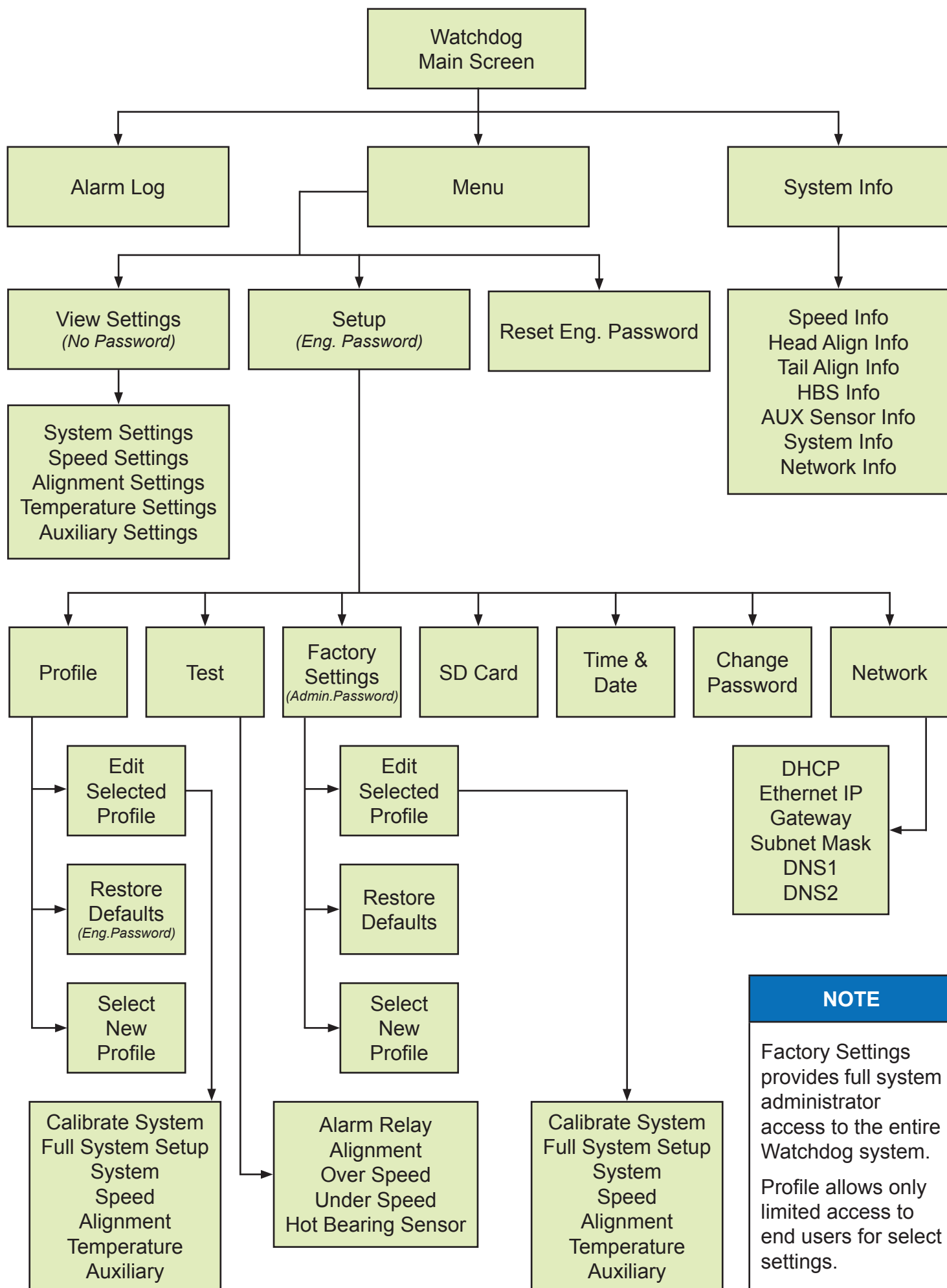

23. APPENDIX B - FACTORY DEFAULT SETTINGS

Some settings are dependent on others, so not all may be displayed or available to select.

SYSTEM	DEFAULT	OPTIONS
• Temperature Units	°F	°F / °C
• Negative Differential Alarm	Off	On / Off
• Rate of Rise Start Up Delay [Min]	3	0 - 5

SPEED	DEFAULT	OPTIONS
• Speed Monitoring	On	On / Off
• Scaling Units	%	PPM / RPM / USR / %
• Scaling Factor	20	User Defined
• Speed detection Source	Dedicated	MAS / Dedicated / Differential
• Acceleration Monitoring Level	5	0 - 9
• Number of Starts / Minute	3	1 - 10
• Start Up Delay [S]	5	1 - 15
• Underspeed Alarm [%]	10	1 - 10
• Severe Underspeed [%]	20	1 - 20
• Underspeed Alarm Delay [S]	1	0 - 10
• Underspeed Stop Delay [S]	60	0 - 60
• Overspeed [%]	10	1 - 10
• Severe Overspeed [%]	20	1 - 20
• Overspeed Alarm Delay [S]	1	0 - 10
• Overspeed Stop delay [S]	60	0 - 60

ALIGNMENT (HEAD & TAIL)	DEFAULT	OPTIONS
• Sensor Pair	Contact	Off / Pulsed / Contact / Rub Block
• Trigger Alarm	Off	On / Off
• Absolute Alarm [Deg]	140 °F	32 - 230 °F
• Relative alarm Source	Off	Off / AMB1 / AMB2 / Opposite
• Relative Alarm [Deg]	30 °F	2 - 90 °F
• Rate of Rise [Deg / Min]	3.0	2.0 - 5.0
• Alarm Delay [S]	1	0 - 10
• Stop Delay [S]	60	0 - 60

Some settings are dependent on others, so not all may be displayed or available to select.

TEMPERATURE	DEFAULT	OPTIONS
• HBS1 - HBS4 (Sensors 1 - 4)	NTC	Off / NTC
• HBS5 - HBS6 (Sensors 5 - 6)	OFF	Off / NTC
• HBS7 - HBS12 (Sensors 7 - 12)*	OFF	Off / NTC Board / PLC Board
• HBS13 - HBS18 (Sensors 13 - 18)*	OFF	Off / NTC Board / PLC Board
• HBS Absolute Alarm [Deg]	140 °F	32 - 230 °F
• HBS Relative Alarm Source	Off	Off / AMB1 / AMB2
• HBS Relative Alarm [Deg]	30 °F	2 - 90 °F
• HBS Rate of Rise [Deg / Min]	3.0	2.0 - 5.0
• HBS Alarm Delay [S]	1	0 - 10
• HBS Stop Delay [S]	60	0 - 60
• AMB1 & AMB2	Off	On / Off
• AMB Absolute Alarm [Deg]	140 °F	32 - 230 °F
• AMB Rate of Rise [Deg / Min]	3.0	2.0 - 5.0
• AMB Alarm Delay [S]	1	0 - 10
• AMB Stop Delay [S]	60	0 - 60

* HBS7 - HBS18 (Sensors 7 - 18) require optional NTC expansion boards to be installed.

AUXILIARY	DEFAULT	OPTIONS
• Plug Enabled	No	Yes / No
• Plug Trigger Alarm When	Off	On / Off
• Plug Alarm Delay [S]	1	0 - 10
• Plug Stop Delay [S]	3	0 - 60
• Pulley Enabled	No	Yes / No
• Pulley Trigger Alarm When	Off	On / Off
• Pulley Alarm Delay [S]	1	0 - 10
• Pulley Stop Delay [S]	5	0 - 60

NOTE

If SELECT NEW PROFILE has been chosen under the PROFILE menu, factory defaults may change depending on the profile selected.

24. APPENDIX C - WDC4 CONFIGURATOR SOFTWARE

The Watchdog Super Elite can be programmed directly through the controller's LCD menu screen, or by using the WDC4 Configurator Software. The software tool makes programming the Watchdog easier by providing all the system settings for each profile menu into one screen (Image 40).

Once a profile setup file has been created, it can be saved to an SD card and then uploaded to the Watchdog by inserting the card into the System Card / SD Card 1 slot (Image 41) inside the control unit. For remote sites, the file can be emailed to an on-site technician, who can upload the file.

The software does not ship with the Watchdog, it is available as a free download at: www.go4b.com/software.

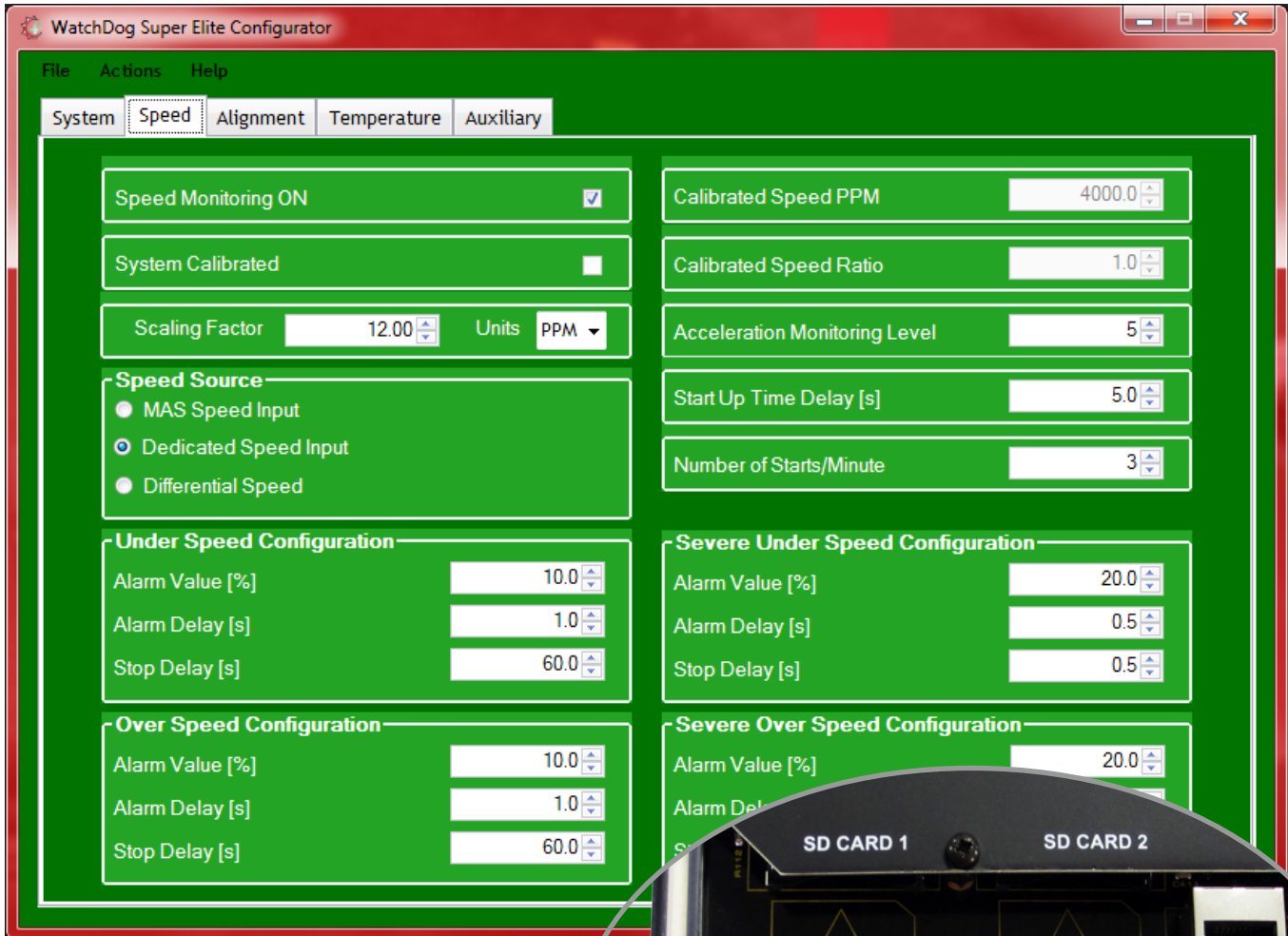

Image 40
WDC4 Configurator Screen Shot



Image 41
Inside View -
SD Card 1 & 2

WARNING

Power down the Watchdog before inserting or removing the SD card from either the SD CARD 1 or SD CARD 2 slots to prevent system errors.

25. APPENDIX D - WDC4 SOFTWARE UPDATE

In order to receive software update notifications by email, please be sure to register your Watchdog Super Elite online at: <http://www.go4b.com/usa> and choose the “Product Registration” link.

BEFORE YOU START -

Make sure to backup the system configuration settings currently installed on your Watchdog by following these steps:

1. Install an SD card into the SD CARD 1 slot (Image 41).
2. From the Watchdog’s main LCD screen, choose **MENU > SETUP (PASSWORD) > SD CARD**.
3. Select SAVE FILE .WD4.
4. Remove the SD card when the file has been saved, and keep it in a safe place.

HOW TO UPDATE -

Download the latest software version to your PC, there will be two files: U102.hex and U201.hex. To install the update to the Watchdog, follow these steps:

1. Load the software onto an SD card, make sure it is not the same card that contains the backup copy.
2. Open the lid of the Watchdog by loosening the two outside screws on the right hand side. Be careful not to touch any of internal wiring, especially the power supply.
3. Place the SD card into the LANGUAGE / SD CARD 2 slot (Image 41) located on the inside lid and press the RESET button on the circuit board (Image 42).
4. Wait for the unit to power up and display the main LCD screen.
5. Place the SD card into the SYSTEM / SD CARD 1 slot and press the RESET button again.
6. During the initial power up (Image 43) check that the new software version has been successfully loaded (Main IC).
7. After the update has successfully loaded, remove the SD card.
8. Secure the lid of the unit by re-tightening the screws.

If the new software did not install, repeat the software update process. If the upload continues to fail, contact 4B.

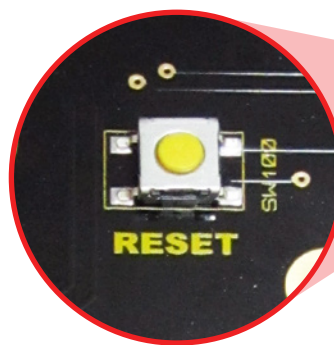

Image 42
Reset Button

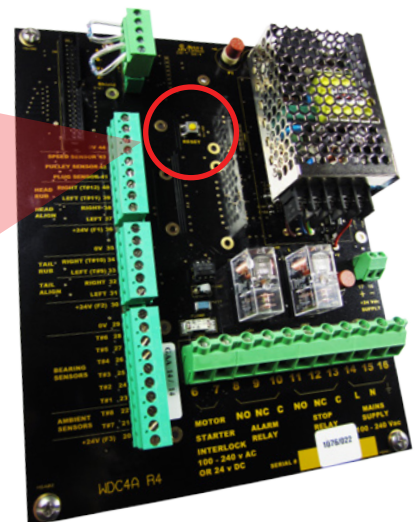

Image 43
Initial Power Up Screen

⚠ WARNING

Power down the Watchdog before inserting or removing the SD card from either the SD CARD 1 or SD CARD 2 slots to prevent system errors.

26. PRODUCT WARRANTY

1. EXCLUSIVE WRITTEN LIMITED WARRANTY

ALL PRODUCTS SOLD ARE WARRANTED BY THE COMPANY 4B COMPONENTS LIMITED AND 4B BRAIME COMPONENTS LIMITED HEREIN AFTER REFERRED TO AS 4B TO THE ORIGINAL PURCHASER AGAINST DEFECTS IN WORKMANSHIP OR MATERIALS UNDER NORMAL USE FOR ONE (1) YEAR AFTER DATE OF PURCHASE FROM 4B. ANY PRODUCT DETERMINED BY 4B AT ITS SOLE DISCRETION TO BE DEFECTIVE IN MATERIAL OR WORKMANSHIP AND RETURNED TO A 4B BRANCH OR AUTHORIZED SERVICE LOCATION, AS 4B DESIGNATES, SHIPPING COSTS PREPAID, WILL BE, AS THE EXCLUSIVE REMEDY, REPAIRED OR REPLACED AT 4B'S OPTION.

2. DISCLAIMER OF IMPLIED WARRANTY

NO WARRANTY OR AFFIRMATION OF FACT, EXPRESSED OR IMPLIED, OTHER THAN AS SET FORTH IN THE EXCLUSIVE WRITTEN LIMITED WARRANTY STATEMENT ABOVE IS MADE OR AUTHORIZED BY 4B. 4B SPECIFICALLY DISCLAIMS ANY LIABILITY FOR PRODUCT DEFECT CLAIMS THAT ARE DUE TO PRODUCT MISUSE, ABUSE OR MISAPPLICATIONS, AS AUTHORIZED BY LAW, 4B SPECIFICALLY DISCLAIMS ALL WARRANTIES THAT THE PRODUCT IS FIT OR MERCHANTABLE FOR A PARTICULAR PURPOSE.

3. NO WARRANTY "BY SAMPLE OR EXAMPLE"

ALTHOUGH 4B HAS USED REASONABLE EFFORTS TO ACCURATELY ILLUSTRATE AND DESCRIBE THE PRODUCTS IN ITS CATALOGS, LITERATURE, AND WEBSITES, SUCH ILLUSTRATIONS AND DESCRIPTIONS ARE FOR THE SOLE PURPOSE OF PRODUCT IDENTIFICATION AND DO NOT EXPRESS OR IMPLY A WARRANTY AFFIRMATION OF FACT, OF ANY KIND OR A WARRANTY OR AFFIRMATION OF FACT THAT THE PRODUCTS WILL CONFORM TO THEIR RESPECTIVE ILLUSTRATIONS OR DESCRIPTIONS. 4B EXPRESSLY DISCLAIMS ANY WARRANTY OR AFFIRMATION OF FACT, EXPRESSED OR IMPLIED, OTHER THAN AS SET FORTH IN THE EXCLUSIVE WRITTEN LIMITED WARRANTY STATEMENT ABOVE, INCLUDING, WITHOUT LIMITATION, THE IMPLIED WARRANTIES OF MERCHANTABILITY AND FITNESS FOR A PARTICULAR PURPOSE.

4. LIMITATION OF DAMAGES

ANY LIABILITY FOR CONSEQUENTIAL, INCIDENTAL, SPECIAL, EXEMPLARY, OR PUNITIVE DAMAGES, OR FOR LOSS OF PROFIT WHETHER DIRECT OR INDIRECT, IS EXPRESSLY DISCLAIMED.

With subsidiaries in North America, Europe, Asia, Africa and Australia along with a worldwide network of distributors, 4B can provide practical solutions for all your applications no matter the location.



**4B BRAIME
COMPONENTS LTD.**

Hunslet Road
Leeds
LS10 1JZ
United Kingdom
Tel: +44 (0) 113 246 1800
Fax: +44 (0) 113 243 5021

4B DEUTSCHLAND

9 Route de Corbie
Lamotte Warfusée
F-80800
France
Tel: +49 (0) 700 2242 4091
Fax: +49 (0) 700 2242 3733

4B ASIA PACIFIC

Build No. 899/1 Moo 20
Soi Chongsiri, Bangplee-Tam Ru Road,
Tanbon Bangpleeyai, Amphur Bangplee,
Samutprakarn 10540
Thailand
Tel: +66 (0) 2 173-4339
Fax: +66 (0) 2 173-4338

4B COMPONENTS LTD.

625 Erie Avenue
Morton, IL 61550
USA
Tel: 309-698-5611
Fax: 309-698-5615

4B FRANCE

9 Route de Corbie
80800 Lamotte Warfusée
France
Tel: +33 (0) 3 22 42 32 26
Fax: +33 (0) 3 22 42 37 33

4B AFRICA

14 Newport Business Park
Mica Drive, Kya Sand
2163 Johannesburg
South Africa
Tel: +27 (0) 11 708 6114
Fax: +27 (0) 11 708 1654

4B AUSTRALIA

Unit 1/18 Overlord Place
Acacia Ridge
Queensland 4110
Australia
Tel: +61 (0) 7 3711 2565
Fax: +61 (0) 7 3711 2574

www.go4b.com