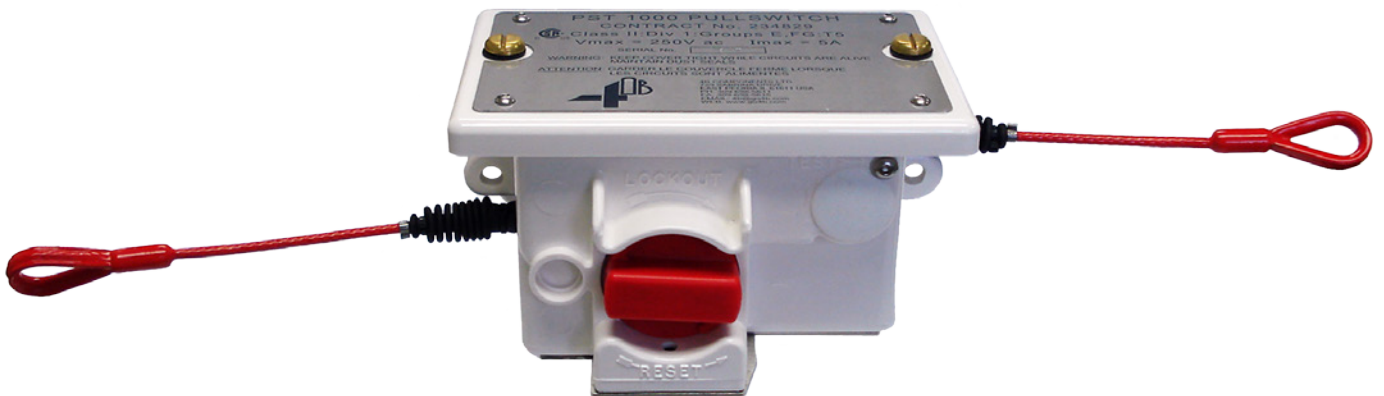




# Pullswitch

OPEN CONVEYOR EMERGENCY  
PULL CORD SAFETY STOP SWITCH

  
C <sup>®</sup> US  
APPROVED  
Class II Div. 1



**INSTALLATION INSTRUCTIONS**

# OPERATION MANUAL


Part No. PST1000C



[www.go4b.com/usa](http://www.go4b.com/usa)



# TABLE OF CONTENTS

CUSTOMER SAFETY RESPONSIBILITIES	Page 4 - 5
PRODUCT OVERVIEW	Page 6
SPECIFICATIONS	Page 6
DIMENSIONS	Page 7
TYPICAL CONFIGURATIONS	Page 8 - 9
STANDARD WIRING DIAGRAM	Page 10
INSTALLATION	Page 11
TESTING & COMMISSIONING	Page 11
TROUBLESHOOTING GUIDE	Page 12
PARTS & ACCESSORIES	Page 12
INSTALLATION IMAGES	Page 13
PRODUCT WARRANTY	Page 15

 **WARNING**

**Moving parts can crush and cut.**  
**Lockout power before removing guard or servicing.**  
**Do NOT operate with guard removed**

 **DANGER**

**Exposed moving parts will cause severe injury or death.**  
**Lockout power before removing cover or inspection door.**

Dear 4B Customer:

Congratulations on your purchase. 4B appreciates your business and is pleased you have chosen our products to meet your needs.

Please read in its entirety and understand the literature accompanying the product before you place the product into service. Please read the safety precautions carefully before operating the product. With each product you purchase from 4B, there are some basic but important safety considerations you must follow to be sure your purchase is permitted to perform its design function and operate properly and safely, giving you many years of reliable service. Please read and understand the Customer Safety Responsibilities listed below. Failure to follow this safety directive and the Operation Manuals and other material furnished or referenced, may result in serious injury or death.

### ***SAFETY NOTICE TO OUR CUSTOMERS***

- A. In order to maximize efficiency and safety, selecting the right equipment for each operation is vital. The proper installation of the equipment, and regular maintenance and inspection is equally important in continuing the proper operation and safety of the product. The proper installation and maintenance of all our products is the responsibility of the user unless you have asked 4B to perform these tasks.
- B. All installation and wiring must be in accordance with Local and National Electrical Codes and other standards applicable to your industry. (Please see the article “Hazard Monitoring Equipment Selection, Installation and Maintenance” at [www.go4b.com](http://www.go4b.com).) The installation of the wiring should be undertaken by an experienced and qualified professional electrician. Failure to correctly wire any product and/or machinery can result in the product or machine failing to operate as intended, and can defeat its design function.
- C. Periodic inspection by a qualified person will help assure your 4B product is performing properly. 4B recommends a documented inspection at least annually and more frequently under high use conditions.
- D. Please see the last page of this manual for all warranty information regarding this product.

### ***CUSTOMER SAFETY RESPONSIBILITIES***

#### **1. READ ALL LITERATURE PROVIDED WITH YOUR PRODUCT**

Please read all user, instruction and safety manuals to ensure that you understand your product operation and are able to safely and effectively use this product.

#### **2. YOU BEST UNDERSTAND YOUR NEEDS**

Every customer and operation is unique, and only you best know the specific needs and capabilities of your operation. Please call the 24-hour hotline at 309-698-5611 for assistance with any questions about the performance of products purchased from 4B. 4B is happy to discuss product performance with you at any time.

### **3. SELECT A QUALIFIED AND COMPETENT INSTALLER**

Correct installation of the product is important for safety and performance. If you have not asked 4B to perform the installation of the unit on your behalf, it is critical for the safety of your operation and those who may perform work on your operation that you select a qualified and competent electrical installer to undertake the installation. The product must be installed properly to perform its designed functions. The installer should be qualified, trained, and competent to perform the installation in accordance with Local and National Electrical Codes, all relevant OSHA Regulations, as well as any of your own standards and preventive maintenance requirements, and other product installation information supplied with the product. You should be prepared to provide the installer with all necessary installation information to assist in the installation.

### **4. ESTABLISH AND FOLLOW A REGULAR MAINTENANCE AND INSPECTION SCHEDULE FOR YOUR 4B PRODUCTS**

You should develop a proper maintenance and inspection program to confirm that your system is in good working order at all times. You will be in the best position to determine the appropriate frequency for inspection. Many different factors known to the user will assist you in deciding the frequency of inspection. These factors may include but are not limited to weather conditions; construction work at the facility; hours of operation; animal or insect infestation; and the real-world experience of knowing how your employees perform their jobs. The personnel or person you select to install, operate, maintain, inspect or perform any work whatsoever, should be trained and qualified to perform these important functions. Complete and accurate records of the maintenance and inspection process should be created and retained by you at all times.

### **5. RETAIN AND REFER TO THE OPERATION MANUAL FOR 4B'S SUGGESTED MAINTENANCE AND INSPECTION RECOMMENDATIONS**

As all operations are different, please understand that your specific operation may require additional adjustments in the maintenance and inspection process essential to permit the monitoring device to perform its intended function. Retain the Operation Manual and other important maintenance and service documents provided by 4B and have them readily available for people servicing your 4B equipment. Should you have any questions, please call the free 24-hour hotline number (309-698-5611).

### **6. SERVICE REQUEST**

If you have questions or comments about the operation of your unit or require the unit to be serviced please contact the 4B location who supplied the product or send your request via fax (309-698-5615) or call us via our 24-hour hotline number in the USA (309-698-5611). Please have available product part numbers, serial numbers, and approximate date of installation. In order to assist you, after the product has been placed into service, complete the online product registration section which is accessed via our website [www.go4b.com/usa](http://www.go4b.com/usa).

## **! WARNING**

Always lockout and tagout the machine prior to installation, and follow all other safety procedures.

## **PRODUCT OVERVIEW**

The Pullswitch is a fail-safe taut wire emergency pull cord safety stop switch for open conveyors.

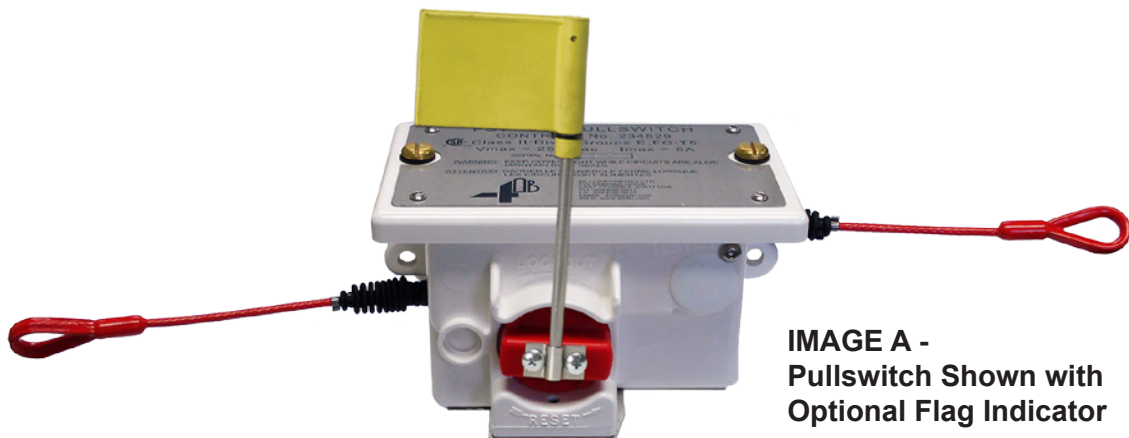
PVC coated steel pull wire and pigtailed connect between the switches to provide easy installation and continuous emergency stop access along the length of the entire conveyor. The unique open curled design of the pigtail allows the pull wire to be installed or removed without disconnecting the entire assembly. Pullswitches can be installed at 200 ft. intervals, reducing overall system cost. Quick location of a tripped switch is provided by a cat's eye reflector or optional flag indicator, and the tripped signal can be wired back to the motor starter and an alarm panel or PLC.

The Pullswitch is a taut wire device, so if wire tension is lost the unit will trip. This design provides a secondary level of safety protection if the pull wire is damaged, or becomes slack.

The Pullswitch has an IP65 / NEMA 4, 4X, 9 rated enclosure made from polycarbonate with stainless steel plates, making the housing corrosion resistant and weatherproof. A total of six independent changeover contacts inside the Pullswitch offer flexible operation and control. Two independent cam operated switches with snap action mechanical operation are provided for conveyor shutdown, and four additional micro-switches signal a slack wire alarm.

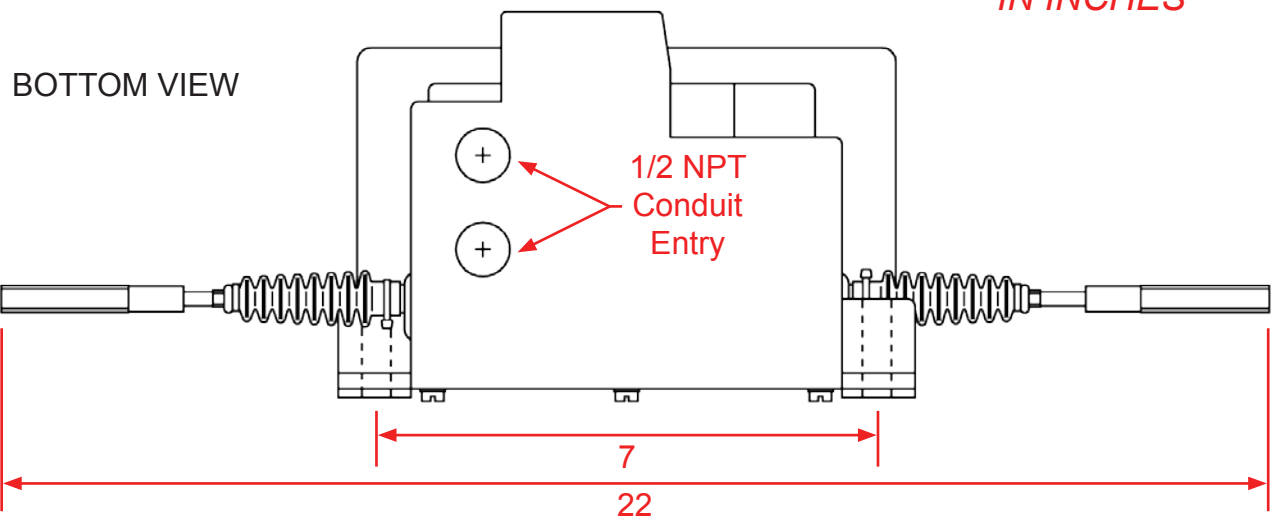
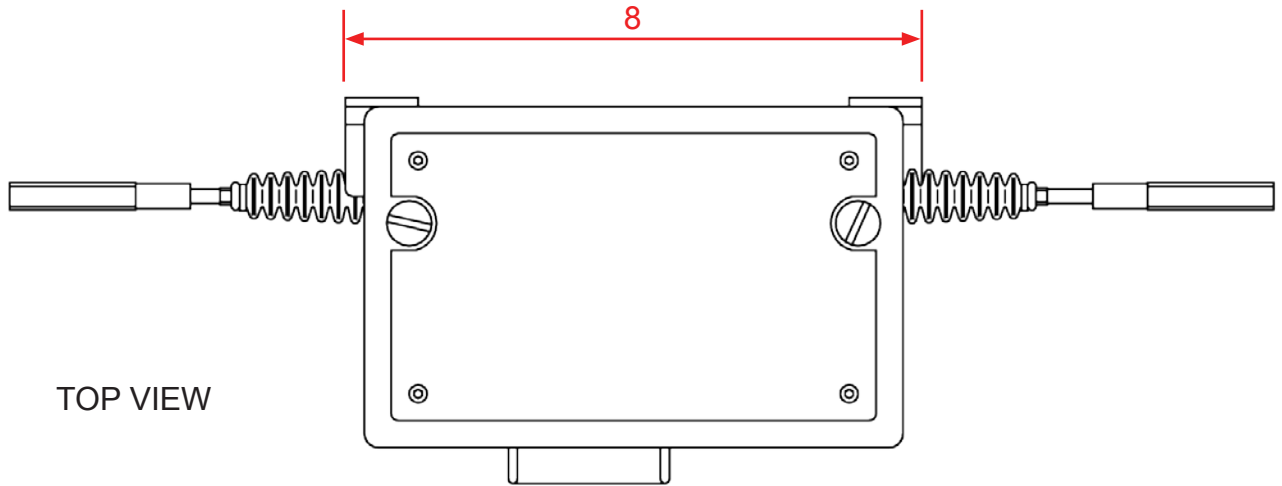
## **SPECIFICATIONS**

Enclosure -	UV Protected Polycarbonate with Protective 304 Stainless Steel Plates (Top, Back and Bottom)
Mechanism -	Double Ended Taut Wire
Activation Pull Force -	15.5 lbs. / 69 Newtons (Calculated Average)
Pull Wire Deflection -	9.8 in / 250 mm (Calculated Average)
Contacts -	5 Amps (240 VAC)
Conduit Entries -	Two - 1/2" NPT
Operating Temperature -	- 4°F to 131°F (-20°C to 55°C)
Weight -	4 lb. (1.8 kg)
Protection -	IP65 / NEMA 4, 4X, 9
Approvals -	CSA Class II Div 1 Groups E, F and G (USA and Canada)

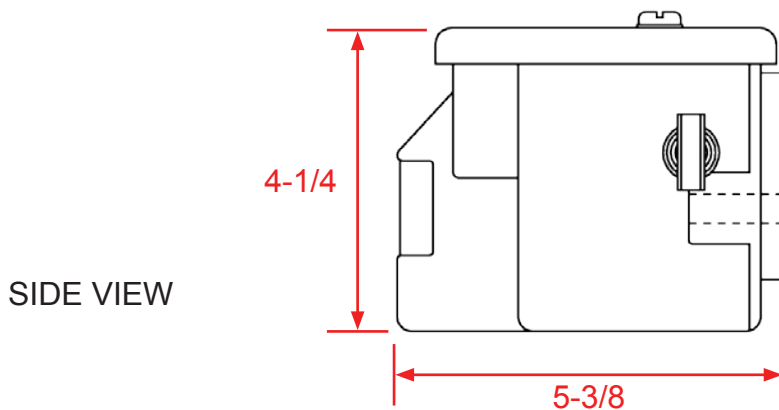
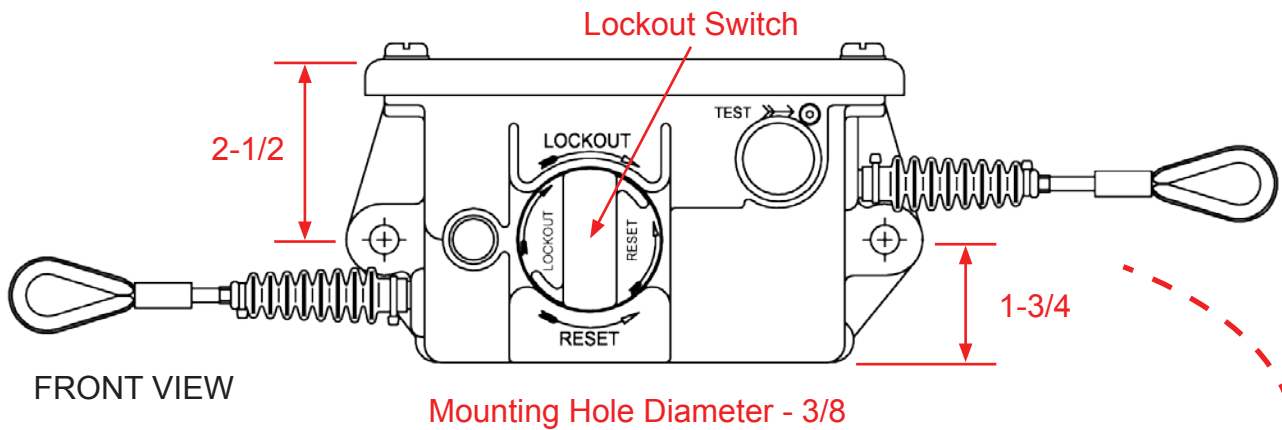


**IMAGE A -  
Pullswitch Shown with  
Optional Flag Indicator**

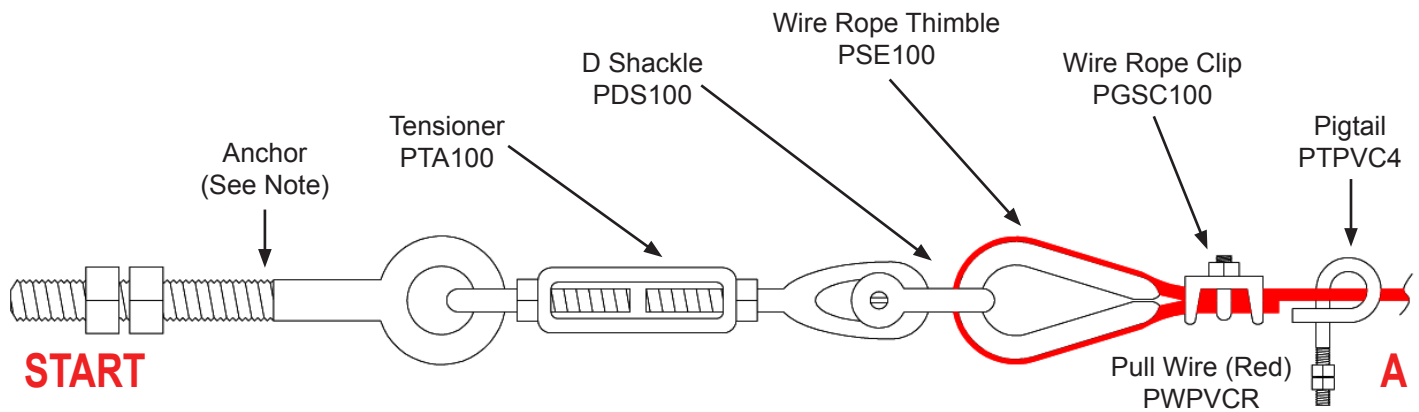
# DIMENSIONS



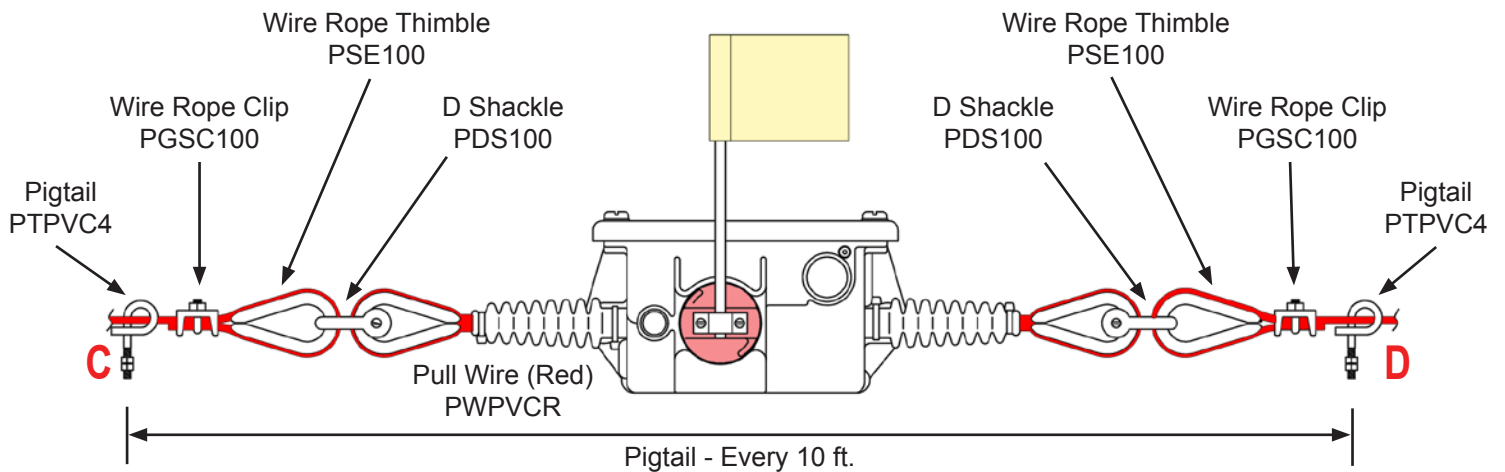
ALL DIMENSIONS  
IN INCHES



# TYPICAL CONFIGURATIONS



**ILLUSTRATION 1 - Start of Pull Wire Configuration**



**ILLUSTRATION 3 - Configuration for Single Pullswitch**

The need for single or double sided installations will depend on your specific application. Some conveyors are not accessible on both sides, so only a one sided installation is needed. However, if your conveyor is accessible on both sides, a two sided installation is required. For double sided installations, 4B recommends mirroring Pullswitch installations on both sides of the conveyor.

Use the illustrations 1 - 4 above as a reference for the installation configurations listed below -

1. Single Pullswitch Installation -  
START - A - C - D - B - END
2. Multiple Pullswitch Installation (2 Pullswitch Configuration) -  
START - A - C - D - E - F - B - END
3. Multiple Pullswitch Installation (3 Pullswitch Configuration) -  
START - A - C - D - E - F - E - F - B - END  
E - F may need to be repeated depending on the length of the conveyor.

For conveyor lengths of 200 feet and under, a single Pullswitch (per side) can be used. For conveyor lengths over 200 feet, multiple Pullswitches will be required.

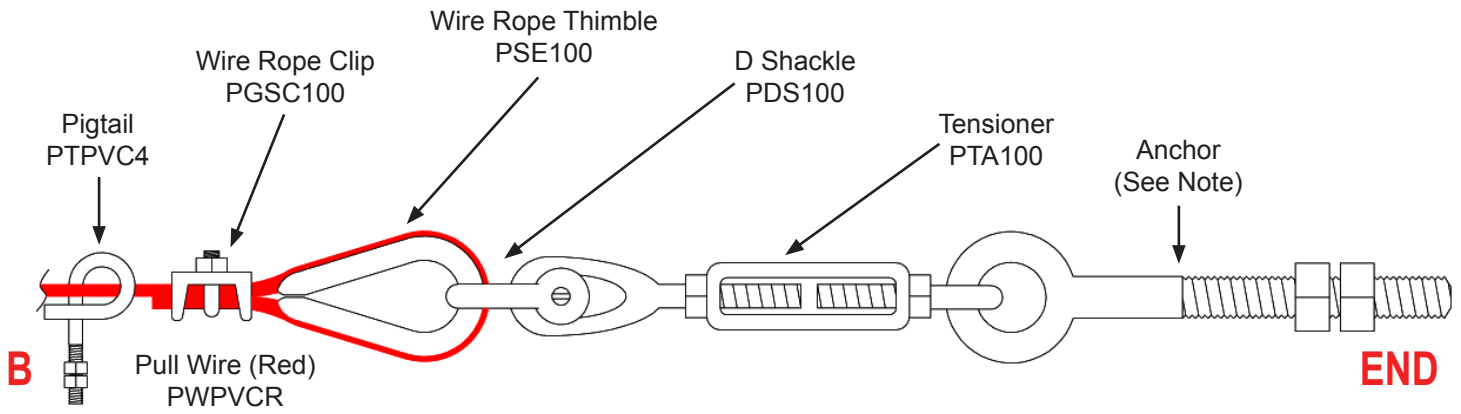
Illustrations 5 and 6 outline the maximum recommended distances for single and multiple installation configurations. Maximum distances of pull wire start and end points to the Pullswitch is 100 feet. Maximum distance between multiple Pullswitches is 200 feet.

## NOTE

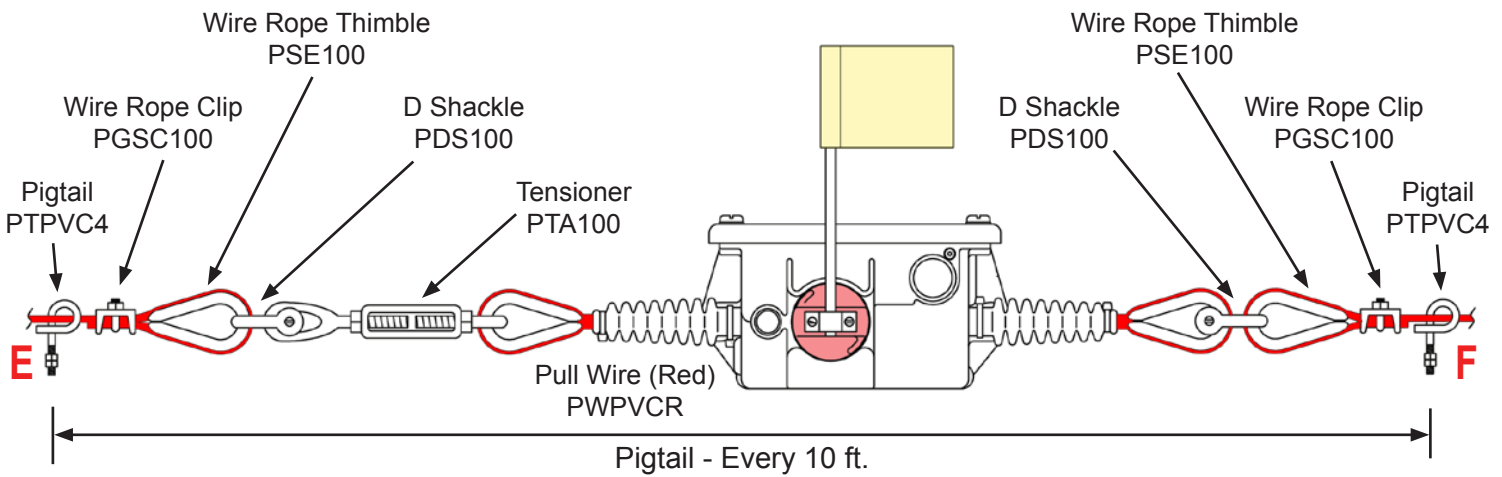
More Pullswitch installation diagrams available at - [www.go4b.com/pullswitch](http://www.go4b.com/pullswitch).



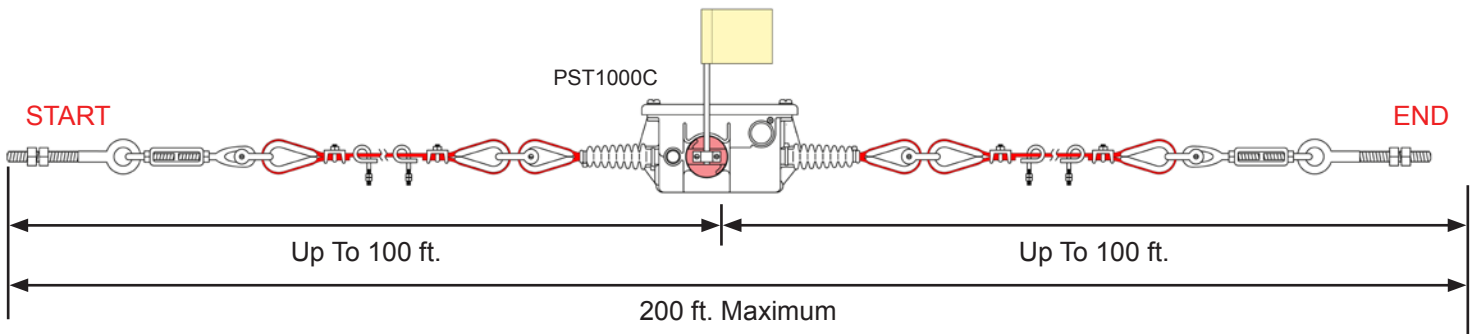
# TYPICAL CONFIGURATIONS



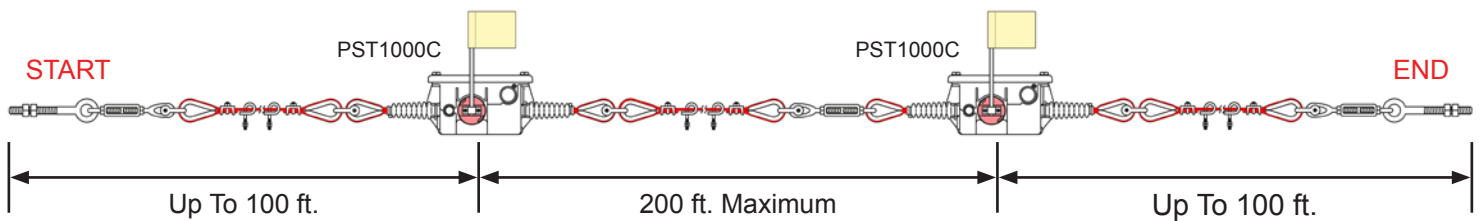
**ILLUSTRATION 2 - End of Pull Wire Configuration**



**ILLUSTRATION 4 - Multiple Pullswitch Configuration**



**ILLUSTRATION 5 - Single Pullswitch Installation**



**ILLUSTRATION 6 - Multiple Pullswitch Installation**

## NOTE

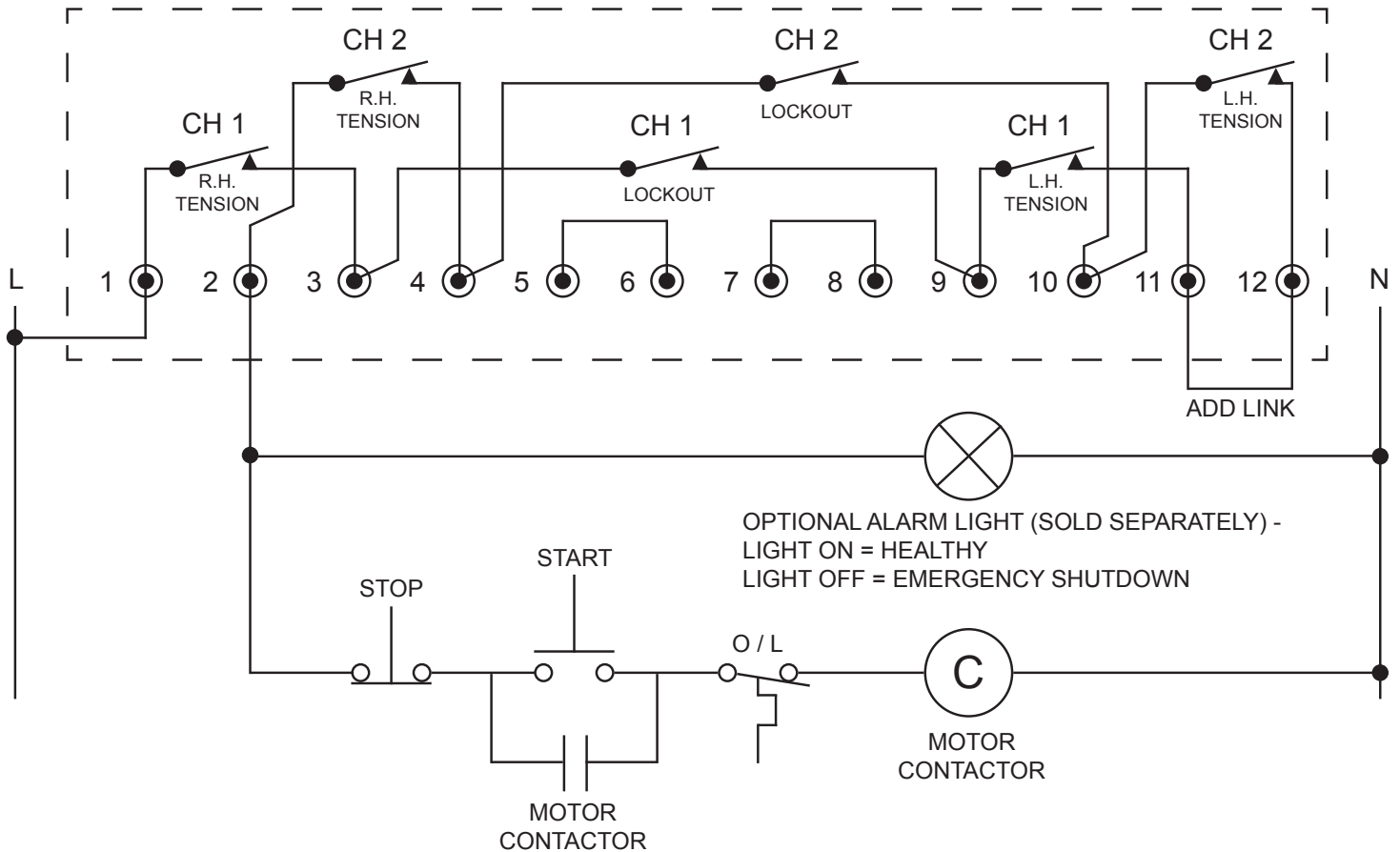
- Install a Pigtail (PTPVC4) every 10 feet along the entire length of the conveyor.
- Some regulations may require an anchor spring (PAS100) at the start and end points instead of fixed anchors as illustrated above.

# STANDARD WIRING DIAGRAM

All wiring must be in accordance with local and national electrical codes and should be undertaken by an experienced and qualified electrician.

Always use dust/liquid tight flexible metal conduit with approved fittings to protect the sensor cables. Use rigid metal conduit to protect the cables from the sensors to the control unit. Conduit systems can channel water due to ingress and condensation directly to sensors and sensor connections which over time will adversely affect the performance of the system. As such, the installation of low point conduit drains is recommended for all sensors.

Contacts Shown in Normal Operating Condition



## NOTE

CH 2 is a backup fail-safe for CH1.

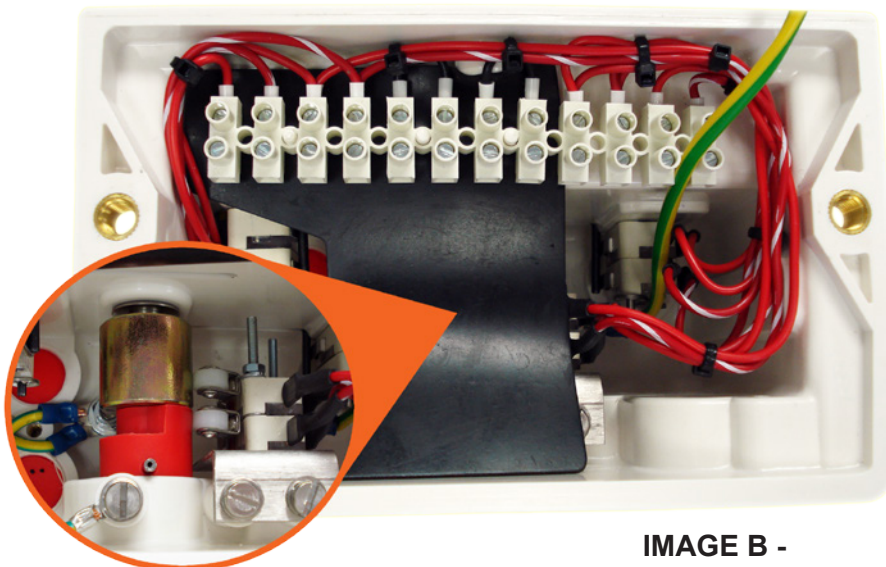
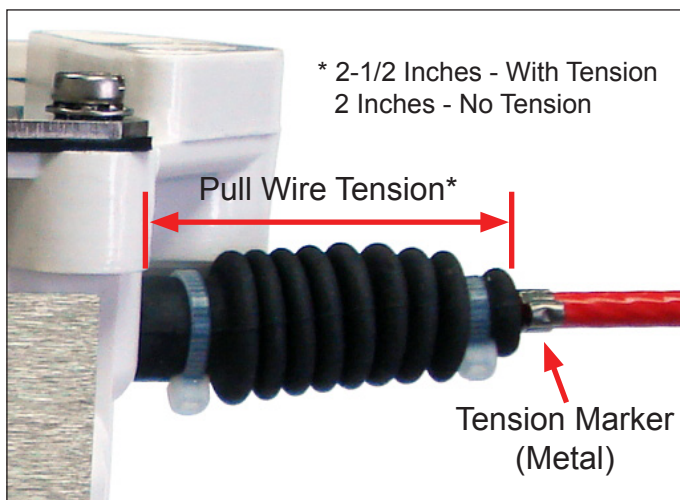


IMAGE B -  
Inside View of Pullswitch

# INSTALLATION

1. Bolt the Pullswitch onto the conveyor structure by using 3/8 inch bolts. Align the Pullswitch so that the pull wire will run along the length of the conveyor and is easily accessible. If a tripper is being used on the conveyor, be careful to avoid its line of travel. Do not over tighten the 3/8 inch bolts.
2. Remove the top cover of the Pullswitch by removing the two fixing screws.
3. Install 1/2 inch NPT dust/liquid tight flexible metal conduit through the bottom of the Pullswitch. Use 1/2 inch NPT plugs on any conduit entry that will not be used.
4. After pulling the incoming and outgoing electrical cables, wire the terminals according to the STANDARD WIRING DIAGRAM on page 10.
5. Make sure that the electrical cables are cut to minimum lengths.
6. Fit pull wire and support guides (pigtails or eyebolts) along the length of the system. Detailed configuration diagrams can be found on pages 8 - 9. For double sided installations, 4B recommends mirroring the installation on both sides of the conveyor.
7. Use cable tensioners at each end and between multiple Pullswitches.
8. The Pullswitch is a taut wire switch, set the tension of the pull wire by adjusting the cable tensioners until the tension marker is 2-1/2 inches from the side of the pullswitch (Image C)



**IMAGE C -  
Pull Wire Tension Indication**

# TESTING & COMMISSIONING

Test the system by pulling the pull wire firmly to the full limit of travel or by turning the red lockout switch on the front of the pullswitch clockwise until it is in the horizontal tripped position. The conveyor should stop immediately.

Reset the system by turning the lockout knob counterclockwise to its original position. If the system does not reset, then check the tension of the cable.

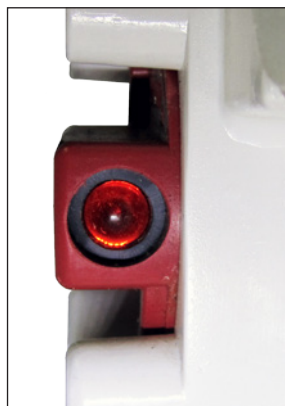
4B recommends inspecting and testing the operation of the system at regular intervals.

## **WARNING**

If the system does not immediately shutdown as expected or alarm as required, then remove the machine from service until the problem has been diagnosed and corrected.

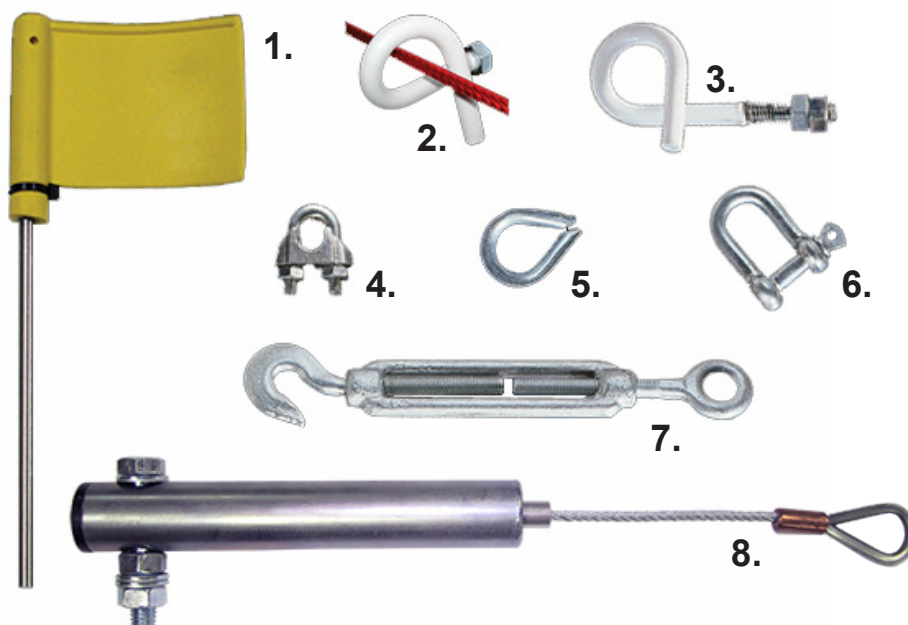
# TROUBLESHOOTING GUIDE

FAULT	REMEDY
Getting an alarm, but the pull wire cable has not been pulled.	Check that there is tension on the cable. The Pullswitch is a taut wire system, so you should get an alarm if the cable is slack or cut.
Multiple Pullswitches installed and getting an alarm, but can not determine which Pullswitch has been activated.	Each Pullswitch has a cat's eye reflector (Image D) so that you can see the reflection of the red lockout switch on the activated unit. In dark areas, simply use a flashlight to spot the reflection of the tripped Pullswitch. There is also an optional flag indicator that can be mounted onto the lockout switch for easier trip detection.



**IMAGE D -  
Cat's Eye Reflector  
on Lockout Switch  
Shown in Tripped  
Position**

## PARTS & ACCESSORIES



- |   |  |
|---|--|
| <ul style="list-style-type: none"> <li>1. PFK100 - Flag Indicator*</li> <li>2. PWPVCR - Pull Wire (Red)</li> <li>3. PTPVCR - PVC Coated Pigtail</li> <li>4. PGSC100 - Wire Rope Clip</li> </ul> | <ul style="list-style-type: none"> <li>5. PSE100 - Wire Rope Thimble</li> <li>6. PDS100 - D-Shackle</li> <li>7. PTA100 - Tensioner</li> <li>8. PAS100 - Anchor Spring</li> </ul> |
|---|--|

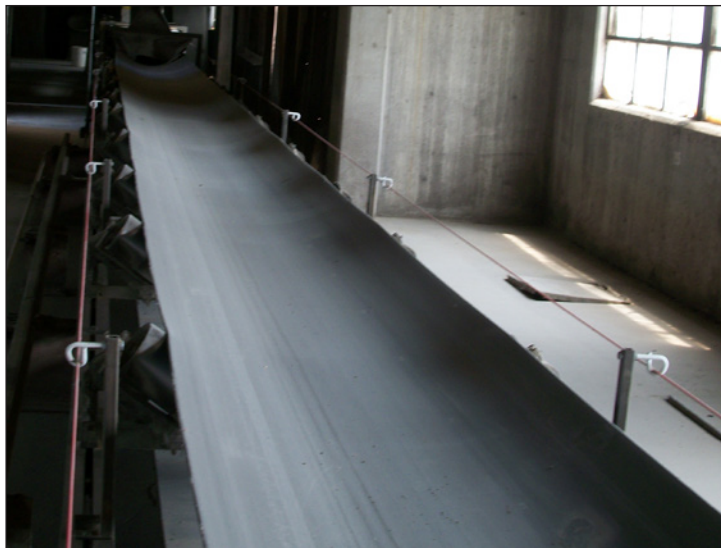
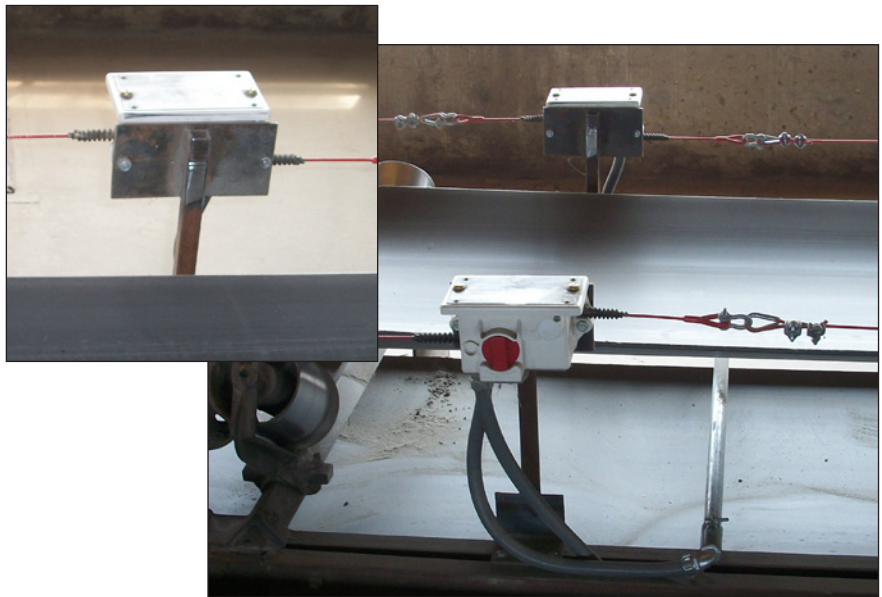
\* Flag indicator attaches directly to lockout switch using supplied bracket and screws.

# INSTALLATION IMAGES



Pullswitch Installed on Open Conveyor at Sand and Gravel Facility

Customer Fabricated  
Brackets for Pullswitch  
Installation at Grain  
Handling Facility



Pull Wire Installation with  
Pigtails Every 10 ft. at  
Grain Handling Facility



# PRODUCT WARRANTY

## 1. EXCLUSIVE WRITTEN LIMITED WARRANTY

ALL PRODUCTS SOLD ARE WARRANTED BY THE COMPANY (4B COMPONENTS LIMITED, (4B) BRAIME ELEVATOR COMPONENTS LIMITED, AND (4B) S.E.T.E.M. Srl) HEREIN AFTER REFERRED TO AS 4B TO THE ORIGINAL PURCHASER AGAINST DEFECTS IN WORKMANSHIP OR MATERIALS UNDER NORMAL USE FOR ONE (1) YEAR AFTER DATE OF PURCHASE FROM 4B. ANY PRODUCT DETERMINED BY 4B AT ITS SOLE DISCRETION TO BE DEFECTIVE IN MATERIAL OR WORKMANSHIP AND RETURNED TO A 4B BRANCH OR AUTHORIZED SERVICE LOCATION, AS 4B DESIGNATES, SHIPPING COSTS PREPAID, WILL BE, AS THE EXCLUSIVE REMEDY, REPAIRED OR REPLACED AT 4B'S OPTION.

## 2. DISCLAIMER OF IMPLIED WARRANTY

NO WARRANTY OR AFFIRMATION OF FACT, EXPRESSED OR IMPLIED, OTHER THAN AS SET FORTH IN THE EXCLUSIVE WRITTEN LIMITED WARRANTY STATEMENT ABOVE IS MADE OR AUTHORIZED BY 4B. 4B SPECIFICALLY DISCLAIMS ANY LIABILITY FOR PRODUCT DEFECT CLAIMS THAT ARE DUE TO PRODUCT MISUSE, ABUSE OR MISAPPLICATIONS, AS AUTHORIZED BY LAW, 4B SPECIFICALLY DISCLAIMS ALL WARRANTIES THAT THE PRODUCT IS FIT OR MERCHANTABLE FOR A PARTICULAR PURPOSE.

## 3. NO WARRANTY "BY SAMPLE OR EXAMPLE"

ALTHOUGH 4B HAS USED REASONABLE EFFORTS TO ACCURATELY ILLUSTRATE AND DESCRIBE THE PRODUCTS IN ITS CATALOGS, LITERATURE, AND WEBSITES, SUCH ILLUSTRATIONS AND DESCRIPTIONS ARE FOR THE SOLE PURPOSE OF PRODUCT IDENTIFICATION AND DO NOT EXPRESS OR IMPLY A WARRANTY AFFIRMATION OF FACT, OF ANY KIND OR A WARRANTY OR AFFIRMATION OF FACT THAT THE PRODUCTS WILL CONFORM TO THEIR RESPECTIVE ILLUSTRATIONS OR DESCRIPTIONS. 4B EXPRESSLY DISCLAIMS ANY WARRANTY OR AFFIRMATION OF FACT, EXPRESSED OR IMPLIED, OTHER THAN AS SET FORTH IN THE EXCLUSIVE WRITTEN LIMITED WARRANTY STATEMENT ABOVE, INCLUDING, WITHOUT LIMITATION, THE IMPLIED WARRANTIES OF MERCHANTABILITY AND FITNESS FOR A PARTICULAR PURPOSE.

## 4. LIMITATION OF DAMAGES

ANY LIABILITY FOR CONSEQUENTIAL, INCIDENTAL, SPECIAL, EXEMPLARY, OR PUNITIVE DAMAGES, OR FOR LOSS OF PROFIT WHETHER DIRECT OR INDIRECT, IS EXPRESSLY DISCLAIMED.

With subsidiaries in North America, Europe, Asia, Africa and Australia along with a worldwide network of distributors, 4B can provide practical solutions for all your applications no matter the location.



**4B BRAIME ELEVATOR COMPONENTS**

Hunslet Road  
Leeds  
LS10 1JZ  
United Kingdom  
Tel: +44 (0) 113 246 1800  
Fax: +44 (0) 113 243 5021

**4B DEUTSCHLAND**

9 Route de Corbie  
Lamotte Warfusée  
F-80800  
France  
Tel: +49 (0) 700 2242 4091  
Fax: +49 (0) 700 2242 3733

**4B ASIA PACIFIC**

Build No. 899/1 Moo 20  
Soi Chongsiri, Bangplee-Tam Ru Road,  
Tanbon Bangpleeyai, Amphur Bangplee,  
Samutprakarn 10540  
Thailand  
Tel: +66 (0) 2 173-4339  
Fax: +66 (0) 2 173-4338

**4B COMPONENTS LTD.**

625 Erie Avenue  
Morton, IL 61550  
USA  
Tel: 309-698-5611  
Fax: 309-698-5615

**4B SETEM SARL**

9 Route de Corbie  
80800 Lamotte Warfusée  
France  
Tel: +33 (0) 3 22 42 32 26  
Fax: +33 (0) 3 22 42 37 33

**4B AFRICA**

14 Newport Business Park  
Mica Drive, Kya Sand  
2163 Johannesburg  
South Africa  
Tel: +27 (0) 11 708 6114  
Fax: +27 (0) 11 708 1654

**4B AUSTRALIA**

Unit 1/18 Overlord Place  
Acacia Ridge  
Queensland 4110  
Australia  
Tel: +61 (0) 7 3711 2565  
Fax: +61 (0) 7 3711 2574

[www.go4b.com](http://www.go4b.com)