

Two Slot MicroTCA[®] Pico Development System with Processor based AdvancedMC[™] Module

Key Features

SY AM1/x22 is a cost effective MicroTCA[®] Pico development system for the evaluation of Concurrent Technologies' Intel[®] or NVIDIA[®] based AdvancedMC[™] modules.

- Two slot system designed for application development and demonstration purposes
- Includes AC power supply and cooling fans
- Available with two free slots or with a processor module and one free slot for an additional module



Option Example: RapidIO Pico System with GPGPU AMC

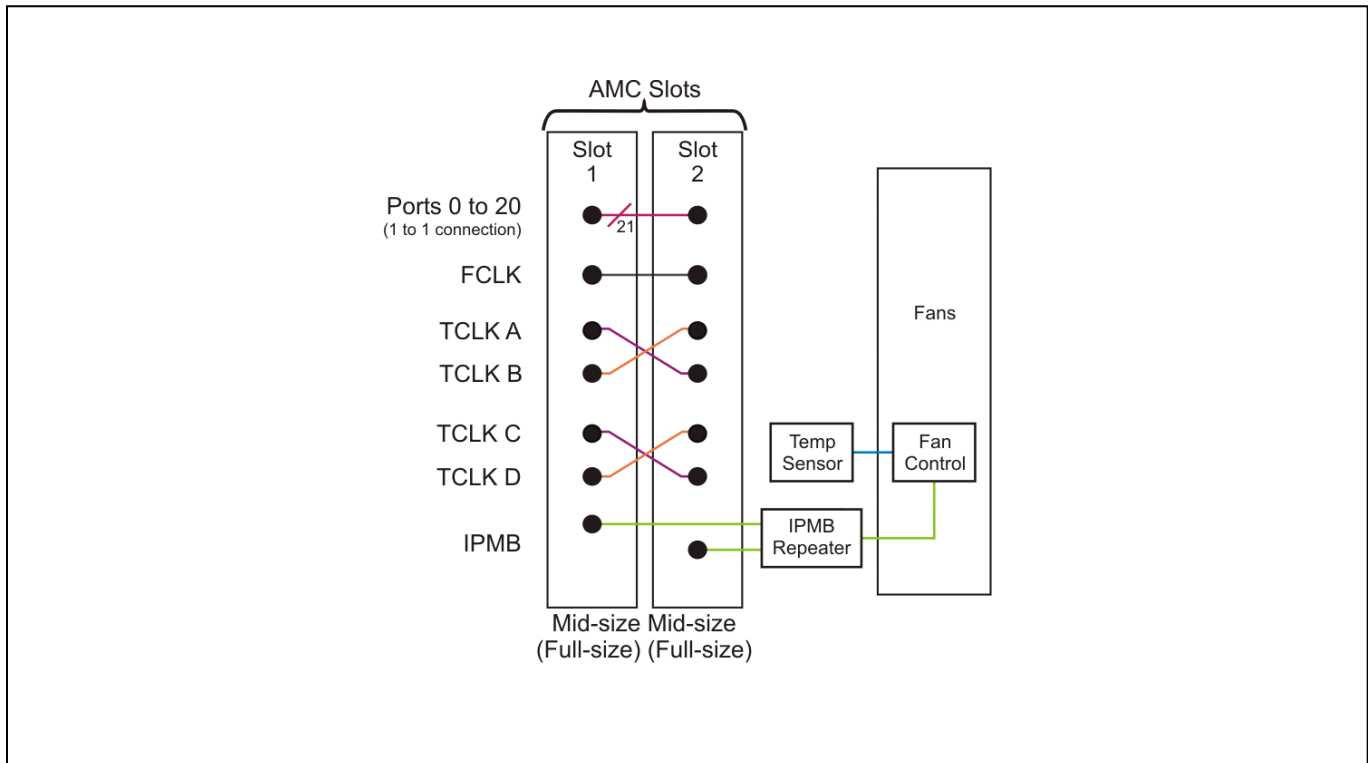

MicroTCA Pico Development System

- MicroTCA® Pico based development system:
 - 2 horizontally mounted Single Module board slots
 - option for 2 x Mid-size slots or 2 x Full-size slots
 - supports PICMG® MicroTCA.0 R1.0 and PICMG AMC.0 R2.0
 - option for pre-installed Intel® processor based AMC module
 - option for pre-installed general-purpose GPU (GPGPU) based AMC module
 - cooling air intake/exhaust at the sides of the system (right to left) with fan speed control
 - rubber feet for desktop use
 - systems can be stacked (and stapled together)
 - board hot-swap is not supported
- MicroTCA backplane provides 2 AMC slots:
 - all 21 ports (0-20) connected between both slots
 - all AMC clocks connected between both slots
 - data transfer rates of up to 10 Gbps per port
- pre-installed processor AMC module includes:
 - on-board SATA Flash Module for application software
 - software support packages
- pre-installed GPGPU AMC module includes:
 - software support packages
- contact your local Concurrent Technologies sales office for further details on all system options

Example: Empty Development System

- option for empty system (chassis) without AMC modules

Example: RapidIO System + CPU AMC

- option for RapidIO Fat Pipes Region with pre-installed processor AMC module:
 - 1 x AM C14/143 Single Module Full-size (4th generation Intel® Core™ processor)
- second slot is empty

Example: RapidIO System + GPGPU AMC

- option for RapidIO Fat Pipes Region with pre-installed GPGPU AMC module:
 - 1 x AG A12/112 Single Module Full-size (2 x NVIDIA® Tegra® K1 processors)
- second slot is empty

Software Support

- supports Linux® and some systems support VxWorks®:
 - proprietary Board Support Package
 - operating system not supplied
- optional Fabric Interconnect Networking Software (FIN-S):
 - allows applications on multiple processor boards to efficiently communicate with each other over the fabric
 - see separate datasheet
 - FIN-S is ordered separately
- contact your local sales office for further details

Power Supply

- integrated Power Supply Unit:
 - +12V output
 - rated power 150 Watt
 - AC 100-240V, 50Hz to 60Hz input

Safety

- PCBs (PWB) manufactured with flammability rating of UL94V-0
- CE mark

Environmental Specification

- operating temperatures:
 - +0°C to +45°C (operating)
 - -25°C to +65°C (storage)
- Relative Humidity, non-condensing:
 - 5% to 85%

Mechanical Specification

- chassis weight excluding AMC modules is approximately 2 kg (4.4 pounds)
- chassis dimensions:
 - width 9.9-inch (252mm) x
 - depth 11.9-inch (302mm) x
 - height 1.7-inch (43.6mm)