

6U CompactPCI[®] board based on 4th Generation Intel[®] Core[™] Processor

Key Features

PP B1x/msd is a single slot air-cooled CompactPCI[®] board, allowing customers to easily migrate to the latest generation of Intel[®] processors for longer system life-cycles.

- Highest performance option features quad-core processor with up to 32 Gbytes of memory
- Dual-core processor options and 16 Gbytes of memory for lower performance applications
- Build option for 2 x 10 Gigabit Ethernet ports on the front panel for higher speed networking
- One or two XMC/PMC module slots for local I/O expansion
- Support for three graphics interfaces
- Optional on-board storage: CFast[™] and 2.5-inch HDD/SSD

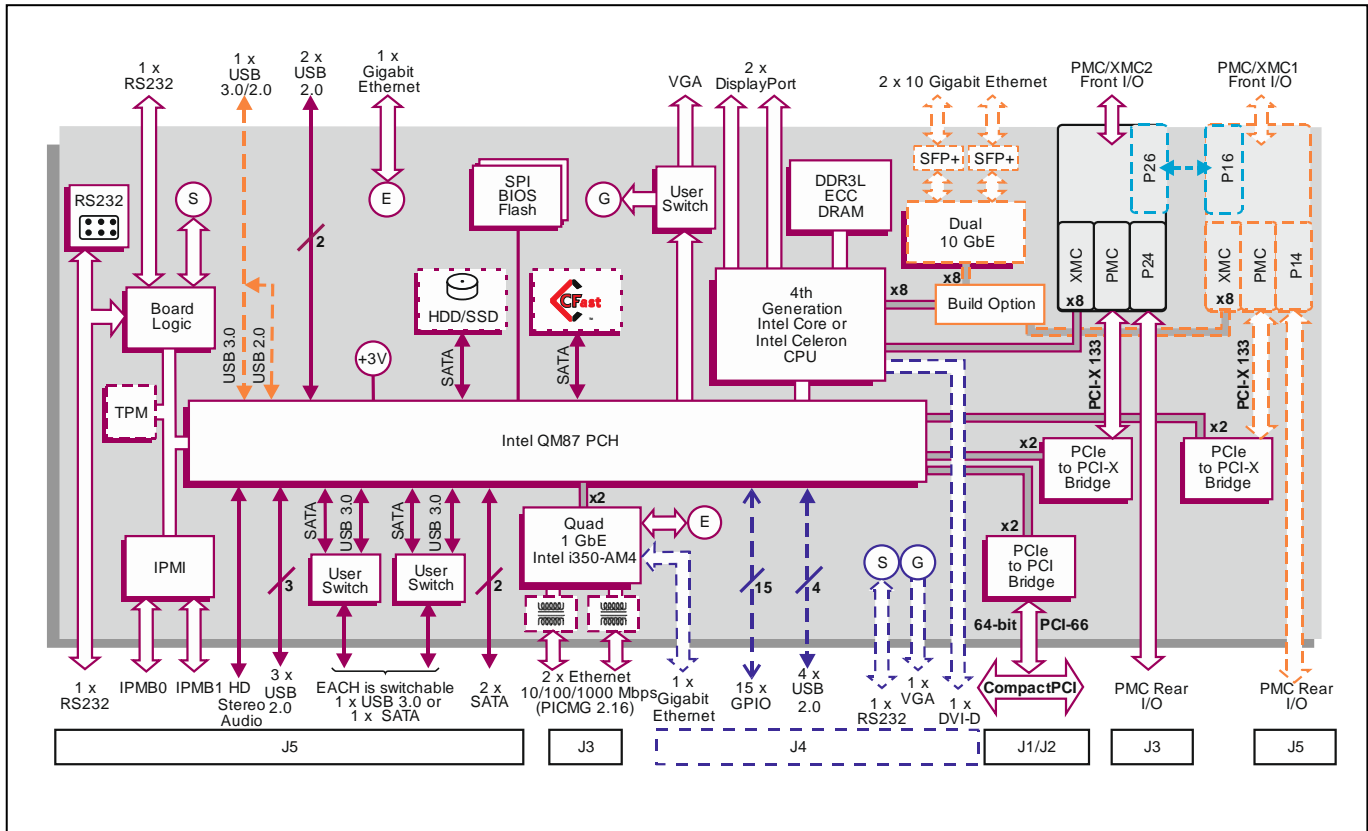
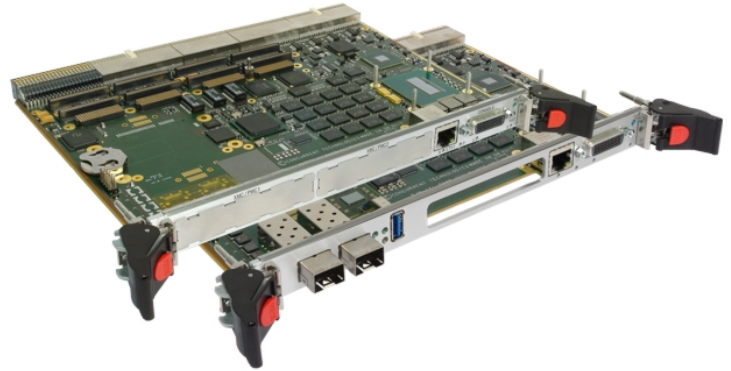

Central Processor

- 4th generation Intel® processor:
 - 4-core Intel® Core™ i7-4700EQ CPU up to 3.4 GHz, 6M Last Level cache
 - 2-core Intel® Core™ i5-4422E CPU up to 2.9 GHz, 3M Last Level cache
 - 2-core Intel® Celeron™ 2002E CPU 1.5 GHz, 2M Last Level cache
 - Intel® Advanced Vector Extensions 2
 - Intel® AES New Instructions (AES not available on Intel Celeron CPU)
- utilizes the Intel® QM87 Platform Controller Hub

DRAM

- 16 or 32 Gbytes soldered DDR3L-1600 ECC DRAM:
 - 16 Gbytes, all CPUs supported
 - 32 Gbytes, 4-core Intel Core i7-4700EQ CPU
 - single bit error correction
 - peak bandwidth of 25.6 Gbytes/s
 - dual channel architecture
- accessible from processor and CompactPCI® bus

Mass Storage Interfaces

- up to 4 x SATA interfaces accessed via J5:
 - 2 x SATA300 interfaces
 - up to 2 x SATA300 interfaces - user selectable, as alternatives to USB 3.0 ports
- 1 x SATA600 supports an on-board CFAST™ site
- 1 x SATA supports an optional on-board 2.5-inch SATA600 mass storage (voids PMC/XMC site 1)

Gigabit Ethernet Interfaces

- up to 4 x 1 Gigabit Ethernet interfaces:
 - supporting 10BASE-T, 100BASE-TX, 1000BASE-T
- 1 x front panel interface via an RJ45 connector
- 2 x rear interfaces via J3:
 - support for PICMG® 2.16 R1.0 - Packet Switching Backplane (build option) or via an optional Rear Transition Module (RTM)
- 1 x rear interface via optional J4
- implemented by an Intel® i350-AM4 controller

10 Gigabit Ethernet Interfaces (option)

- build option (N-Series or E-Series operating temperature only) for 2 x high performance 10 Gigabit Ethernet interfaces via front panel SFP+ modules
- only available with single PMC/XMC site build option

PMC/XMC Interface(s)

- build option for single or dual PMC/XMC interfaces
- PMC/XMC site 1 (available as build option):
 - front panel I/O
 - PMC/XMC P14 rear I/O via J5
- PMC/XMC site 2 (always available):
 - front panel I/O
 - PMC/XMC P24 rear I/O via J3
- PMC site(s) support:
 - 32/64-bit, 33/66MHz PCI bus
 - 64-bit, 133MHz PCI-X™ bus
 - 5V and 3.3V signaling
- XMC site(s) support:
 - x8 PCI Express® port (Gen 1 and Gen 2)
 - powered from 5V supply

Stereo Audio

- Intel® High Definition Digital Audio via J5:
 - optional CoDec on optional RTM

SPI Flash EPROM

- dual 8 Mbytes of BIOS SPI Flash EPROM

Optional Board Security Hardware

- Trusted Platform Module (TPM)

Serial Interfaces

- up to 3 x RS232 serial interfaces:
 - 1 x Tx/Rx interface accessed via a 60-way high-density connector on front panel
 - 1 x serial interface via on-board header or J5
 - 1 x serial interface via optional J4
- J5 (or onboard header) and J4 interfaces support Tx, Rx, RI, CTS, RTS, DSR, DTR and DCD
- 16550 compatible UARTs

Graphics Interfaces

- up to three independent graphics interfaces
- 2 x DisplayPort graphics interfaces via a front panel 60-way high-density connector:
 - up to 2560 x 1600 @ 60Hz
- DVI-D graphics interface via optional J4:
 - up to 1920 x 1200 @ 16M colors
- VGA graphics interface via front panel, user switchable to optional J4:
 - up to 1920 x 1200 @ 16M colors
- support for Microsoft® DirectX 11.1
- support for OpenGL 3.0, Windows® and Linux®

Other Peripheral Interfaces

- PC Real Time Clock
- watchdog timer; 32-bit Long Duration Timer with processor interrupt ability; chipset timer
- voltages monitor; CPU temperature and board temperature monitors; all accessible via IPMI
- up to 3 x USB ports via the front panel I/O:
 - 2 x USB 2.0 ports accessed via a 60-way high-density connector
 - 1 x USB 3.0/2.0 port accessed via a USB connector (single PMC/XMC site option)
- up to 9 x USB ports via rear panel I/O:
 - 4 x USB 2.0 ports accessed via optional J4
 - 3 x USB 2.0 ports accessed via J5
 - up to 2 x USB 3.0 ports accessed via J5 - user selectable, as alternatives to SATA300 ports
- 15 x GPIO signals accessed via optional J4
- independent legacy speaker output via J3

IPMI

- PICMG 2.9 R1.0 (System Management):
 - implements IPMB0/IPMB1 interfaces
- Baseboard Management Controller
- supports 8 Kbytes of non-volatile memory

Software Support

- support for Linux®, Windows® and VxWorks®

Firmware Support

- Insyde Software InsydeH20™ BIOS:
 - includes Compatibility Support Module
- based upon Intel® Platform Innovation Framework for EFI
- Power-On Self-Test (POST)
- LAN boot firmware included

CompactPCI Interface

- compliant with PICMG 2.0 R3.0: 3.3V or 5V signaling levels (universal signaling support)
- 33/66 MHz, 32/64-bit interface accessed via J1/J2 connectors
- PICMG 2.1 R2.0 Hot Swap compliant
- operates as System Slot controller or in a Peripheral slot
- option to disable CompactPCI interface (Satellite Mode):
 - receives power from CompactPCI bus
 - board can be hot swapped

Safety

- PCB (PWB) manufactured with a flammability rating of UL94V-0

Electrical Specification

- typical current figures (based on 4-core CPU 8 GBytes DRAM and dual PMC/XMC sites)
 - +5V @ 7.1A
 - +3.3V @ 4.7A
- +12V and -12V are not required, but are routed to PMC/XMC site(s)

Environmental Specification

- operating temperatures:
 - 0°C to +55°C (N-Series)
 - -25°C to +70°C (E-Series: Selected CPU)
 - -40°C to +70°C (K-Series: Selected CPU)
 - -40°C to +85°C (K-Series: Selected CPU)
- non-operating temperature: -40°C to +85°C
- 5% to 95% Relative Humidity, non condensing:
 - K-Series includes humidity sealant

Mechanical Specification

- 6U form-factor:
 - 9.2 inches x 6.3 inches (233mm x 160mm)
- single slot: 0.8 inches (20.3mm)
- connectors: IEC-1076-4-101 for J1-J5
- operating shock: 20g, 11ms, ½ sine
- operating vibration:
 - 5Hz-2000Hz at 2g, 0.38mm peak displacement