

## 3U CompactPCI board based on Intel® Atom™ Processor E3800

### Key Features

TP D2x/msd is a 3U CompactPCI® board based on an ultra-low power Intel® Atom™ processor. Compatible with legacy TP A41/30x processor boards.

- Intel® Atom™ processor E3800 family:
  - 4-core and 1-core processor options allowing for performance and power optimizations
- Wide spread of front and rear I/O including CAN to suit multiple application needs
- Option for on-board Flash Drive Module and 2.5-inch drive for local storage
- Optional second slot boards provide CompactFlash®, 2.5-inch storage drive and PMC/XMC module
- Board support packages available for Windows®, Linux® and VxWorks®
- Optional Fast Boot support to speed up boot times

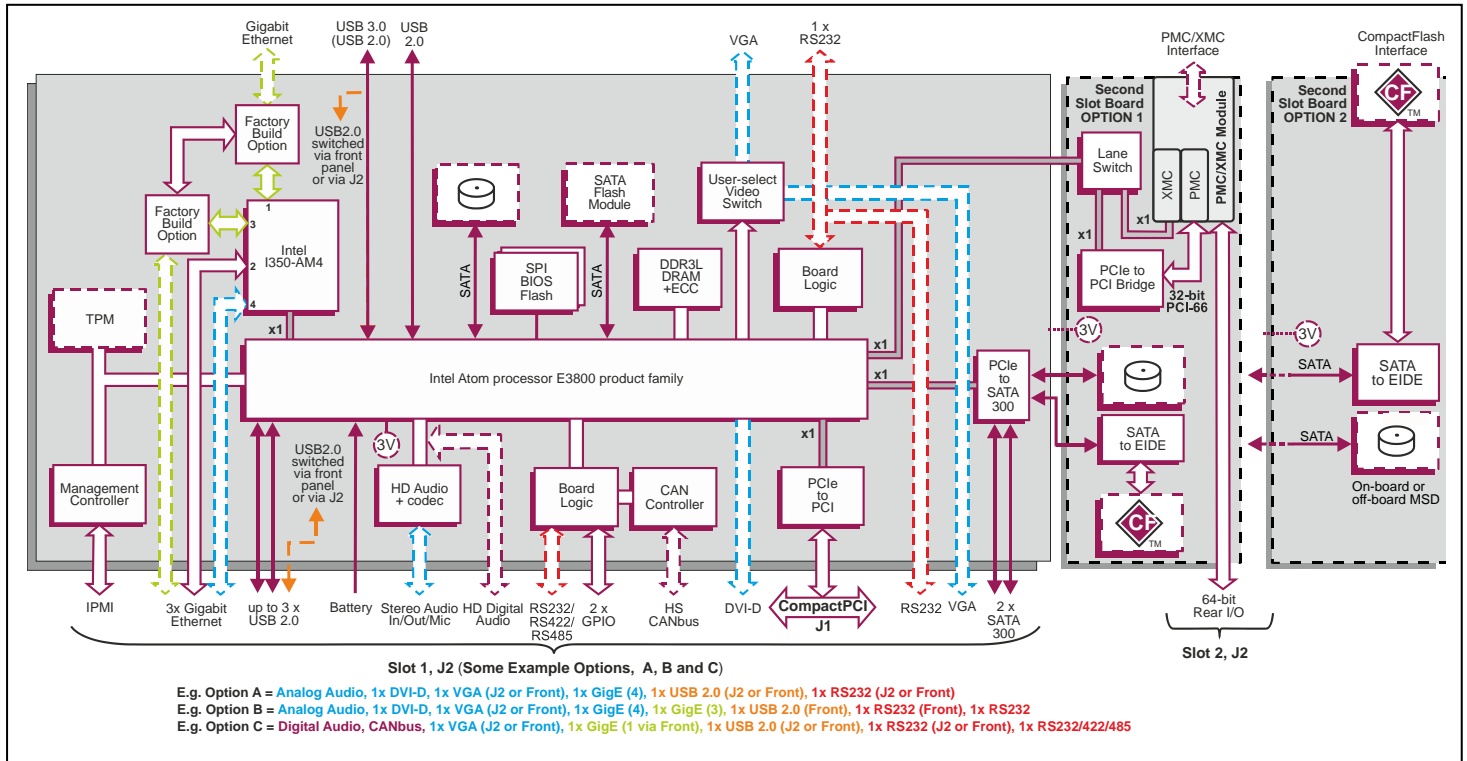

## Central Processor

- Intel® Atom™ processor E3800 product family:
  - 4-core 1.91 GHz Intel® Atom™ processor E3845
  - 1-core 1.46 GHz Intel® Atom™ processor E3815

## DRAM

- 4 Gbytes soldered DDR3L ECC DRAM:
  - peak bandwidth of 10.6 Gbytes/s
  - single channel architecture

## Optional Second Slot Boards

- second slot board, two options (see block diagram)
- build option 1 supports on-board:
  - PMC/XMC site or 2.5-inch SATA300 Mass Storage Drive (MSD)
  - on-board CompactFlash® site
- build option 2 supports on-board:
  - 2.5-inch SATA300 Mass Storage Drive (or external SATA drive via J2)
  - on-board CompactFlash site, accessible via front panel aperture

## PMC/XMC Interface

- single PMC/XMC site available on an optional second slot board (option 1, see block diagram):
  - 32-bit, 33/66 MHz PCI operation
  - 3.3V and 5V PCI signaling levels
  - XMC (Switched Mezzanine Card) interface supported via x1 PCI Express® port
  - I/O via front panel and 64 I/O signals via Pn4 via J2 on second slot board

## Mass Storage Interfaces

- 4 x SATA300 interfaces on main processor board:
  - 2 x SATA via J2
  - 1 x SATA routed to an optional on-board 2.5-inch Mass Storage Drive
  - 1 x SATA routed to an optional on-board Flash Drive Module
- 2 x SATA300 interfaces routed to an optional second slot board (board option 1 or option 2):
  - 1 x SATA routed to an optional 2.5-inch Mass Storage Drive
  - 1 x SATA to EIDE interface routed to a CompactFlash® site

## Ethernet Interfaces

- up to 4 x Gigabit Ethernet interfaces:
  - up to 3 x interfaces via J2
  - one via front panel RJ45 or via J2 (build option)
  - 10BASE-T, 100BASE-TX, 1000BASE-T
- implemented by Intel® I350-AM4 Ethernet Controller

## Stereo Audio

- build option for Intel® High Definition Audio interface via J2 supports either:
  - on-board CoDec provides analog audio (stereo headphone output and microphone input)
  - or digital audio requiring an external CoDec (e.g. on a Rear Transition Module)

## Graphics Interface

- analog VGA graphics interface via a 15-way high density connector on front panel or via J2:
  - resolutions up to 2048 x 1536 @ 16M colors
  - user selectable between front and rear
- DVI-D interface (build option) via J2:
  - resolutions up to 1920 x 1080 @ 60 Hz

## Serial Interfaces

- 1 x RS232 serial port via front panel RJ45 connector supporting:
  - Tx, Rx, RTS, CTS, DSR, DTR, DCD
  - some build options also route this port via J2
- 1 x RS232/422/485 port via J2 supporting:
  - Tx, Rx, RTS, DTR (RS232/422/485 build option)
  - Tx, Rx, RTS, CTS (RS232 build option)
- 16550 compatible UARTs

## Other Peripheral Interfaces

- PC Real Time Clock
- long duration timer; watchdog timer
- 1 x USB 2.0 port via front panel
- 1 x USB 3.0 (with USB 2.0) port(s) via front panel USB Type B connector:
  - USB 2.0 port can be routed via J2 (build option)
- up to 3 x USB 2.0 ports via J2:
  - 1 x port can be routed via the front panel USB Type B connector (build option)
- 2 x GPIO signals via J2
- High Speed CANbus interface via J2 (build option)

## Flash EPROM

- dual 8 Mbytes of BIOS SPI Flash EPROM

## Software Support

- supports Windows®, Linux® and VxWorks®

## Firmware Support

- Insyde Software InsydeH20™ BIOS
- optional Fast Boot solution based on the Intel® Firmware Support Package (Intel® FSP)
- Intel® Platform Innovation Framework for EFI
- LAN boot firmware included

## Optional Built-In Test (BIT) Support

- Power-on BIT (PBIT), Initiated BIT (IBIT), Continuous BIT (CBIT)

## Optional Board Security Packages

- Trusted Platform Module (TPM)
- proprietary board-level security features

## CompactPCI Interface

- universal signaling support, compliant with PICMG® 2.0 R3.0; 3.3V or 5V signaling levels
- 33/66 MHz; 32-bit interface via J1
- operates as a System Slot controller (supporting up to 7 peripheral slots) or operates in a Peripheral Slot
- PICMG 2.1 R2.0 Hot Swap Compliant
- user selectable option to disable CompactPCI® interface (Satellite Mode):
  - receives power from CompactPCI bus
  - board can be hot swapped

## IPMI

- PICMG 2.9 R1.0 (System Management Specification):
  - implements the IPMB0 interface
- on-board Baseboard Management Controller
- monitors CPU board temperature, voltages
- supports 8 Kbytes of non-volatile memory

## Electrical Specification

- typical power consumption is 10W for the 1-core Intel Atom processor E3815 board
- +5V and +3.3V are required:
  - voltages +5%/-3%

## Safety

- PCB (PWB) manufactured with flammability rating of UL94V-0

## Environmental Specification

- commercial operating temperature (N-Series):
  - 0°C to +70°C
- extended operating temperatures (E-Series):
  - -25°C to +70°C
- extended operating temperatures (K-Series):
  - -40°C to +85°C
- supports fanless operation:
  - 4-core fanless operation, +55°C maximum
  - 1-core fanless operation, +70°C maximum
  - includes the 2.5-inch SATA Mass Storage Drive
- for airflow graphs, see Technical Reference Manual
- non-operating temperature: -40°C to +85°C
- 5% to 95% Relative Humidity, non-condensing:
  - K-Series includes humidity sealant
- rugged versions, see separate datasheet:
  - conduction-cooled: TP D2x/msd-RC
  - rear plug compatible

## Mechanical Specification

- 3U form-factor: 3.9 inches x 6.3 inches (100mm x 160mm)
- single or dual slot
- connectors: IEC-1076-4-101 for J1-J2
- operating mechanical:
  - shock - 20g, 11ms, ½ sine
  - vibration - 5Hz-2000Hz at 2g, 0.38mm peak displacement

## Legacy Board Compatibility

- TP D2x/msd front and rear plug compatibility with the popular TP A41/30x family