

GT-3200 SIDEWALK PAYER



GOMACO[®]

The Worldwide Leader in Concrete Paving Technology

GT-3200 Sidewalk Paver

The GT-3200 Sidewalk Paver was born from the demand for high-volume sidewalk replacement in various areas of Canada. The versatility designed into this machine includes a trimmer to prepare the grade or an aggregate mold to place the base. The goal for this product was to design a slipform paver, with our zero clearance expertise to operate in a sidewalk lane alongside trees, power poles, and other obstacles. The long, pivoting and folding conveyor allows continuous paving while the ground person manipulates the conveyor around obstacles to receive concrete from ready-mix trucks on the nearby roadway. All-Track Steering (ATS) was added to this machine as an option for enhanced steering and job-site mobility.



This sidewalk was slipformed by a GT-3200 sidewalk paver within an existing residential area. The paver's minimum clearance allowed for high production on this sidewalk replacement project.

G+® is now the technology that pulls everything together... It is the center that Connects all of the resources.

Once you experience G+ controls, you won't be satisfied with anything else. It's a control system that is both easy to learn and easy to operate. G+ expresses itself in easy to understand international icons and full script explanations. It operates in all the major languages of the world and in imperial or the metric number system. It has a lightning-fast processing speed and features two-way communications between paver accessories and G+. Its instant digital feedback combined with the tight closed-loop electronic and hydraulic control creates a G+ paving experience that is smooth, efficient, and accurate. There is nothing on the market that can compare, because G+ is a proprietary system designed by our in-house control experts based on what we have learned from years of experience in the field and from what we have learned from you, our customer.

- Machine Setup and Operation are Simple
- Machine Response is Faster
- Troubleshooting is Pinpointed, Quicker, and Easier

The exclusive GOMACO G+ control system features self-diagnostics for grade and steering. It features new and easy-to-operate hardware with steering and travel dials. The elevation jog buttons, located to the left of the display screen, are used to manually change the elevation of the leg when the control loop is set to manual mode. The steering jog buttons, located above the display screen, are used to manually change the steer direction of the leg when the control loop is in the manual mode.

A flat 165 millimeter (6.5 inch) anti-glare display screen is provided with sensor-controlled backlight levels for superior visibility in all operating conditions. The screen is rugged and shock resistant in its construction to protect against dust, moisture, and rain. G+ provides a full color display on the control panel to illustrate the various aspects of the paver for set up and operation. A "run" screen on the control panel illustrates the various aspects of the paver. It includes leg position, paving speed and percentage of drive, steering, travel information, grade information and deviation meters, and more. Newly designed icons and color graphics make it easy to understand and easy to identify the targeted functions. G+ controls feature a detailed fault history with the time stamp, date, and information to track when each fault occurred. GOMACO's G+ control system has been proven around the world.



4.27 Meter (14 Ft) Folding Conveyor



The GT-3200 sidewalk paver has a 508 millimeter (20 in) wide, 4.27 meter (14 ft) long folding conveyor. The conveyor allows ready-mix trucks to discharge from the street instead of driving over existing curb to reach the paver.



The conveyor is operated by the ground person to manage how far the conveyor needs to be folded in order to avoid the light pole or other obstacles during paving.



The conveyor is hydraulically placed back to the full 4.27 meter (14 ft) length for paving to continue. The GT-3200 above is slipforming a 2.5 meter (8.2 ft) wide sidewalk.



The conveyor can be raised without being folded in order to avoid a smaller obstacle, allowing the ready-mix trucks to continue placing concrete on the GT-3200 sidewalk paver's conveyor.



The GT-3200 above is slipforming a 2.44 meter (8 ft) wide sidewalk. The hydraulic pivoting conveyor has also been designed to rotate 90 degrees in either direction from center to allow for easy loading of concrete into the hopper from either side of the machine and to avoid obstacles associated with zero-clearance paving.



The conveyor can be manipulated around trees and light poles, while the paver continues the sidewalk pour. The GT-3200 above is slipforming a 1.5 meter (5 ft) wide sidewalk through a residential area.

GT-3200 Sidewalk Paver with Optional Trimmer

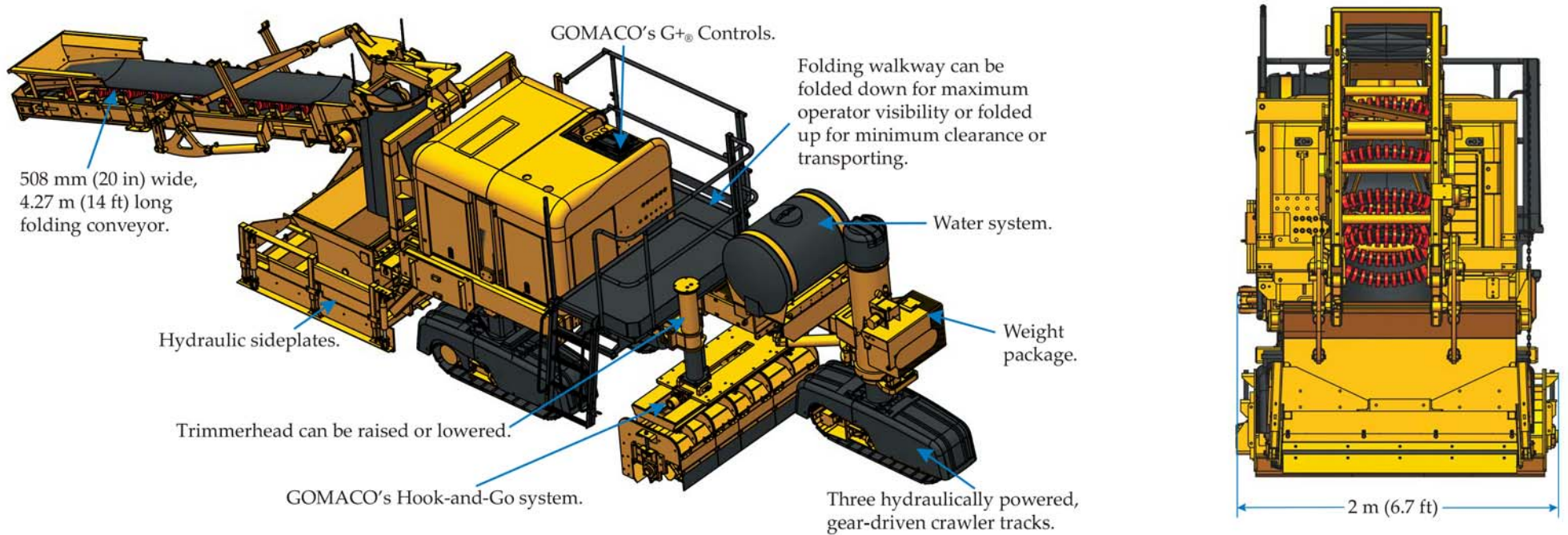

The GT-3200 sidewalk paver can slipform widths up to 3.66 meters (12 ft) with a well-prepared grade.



The GT-3200 sidewalk paver can be equipped with a trimmerhead for fine grade trimming. The GT-3200 above is simultaneously trimming the grade and slipforming the sidewalk for a future residential area.

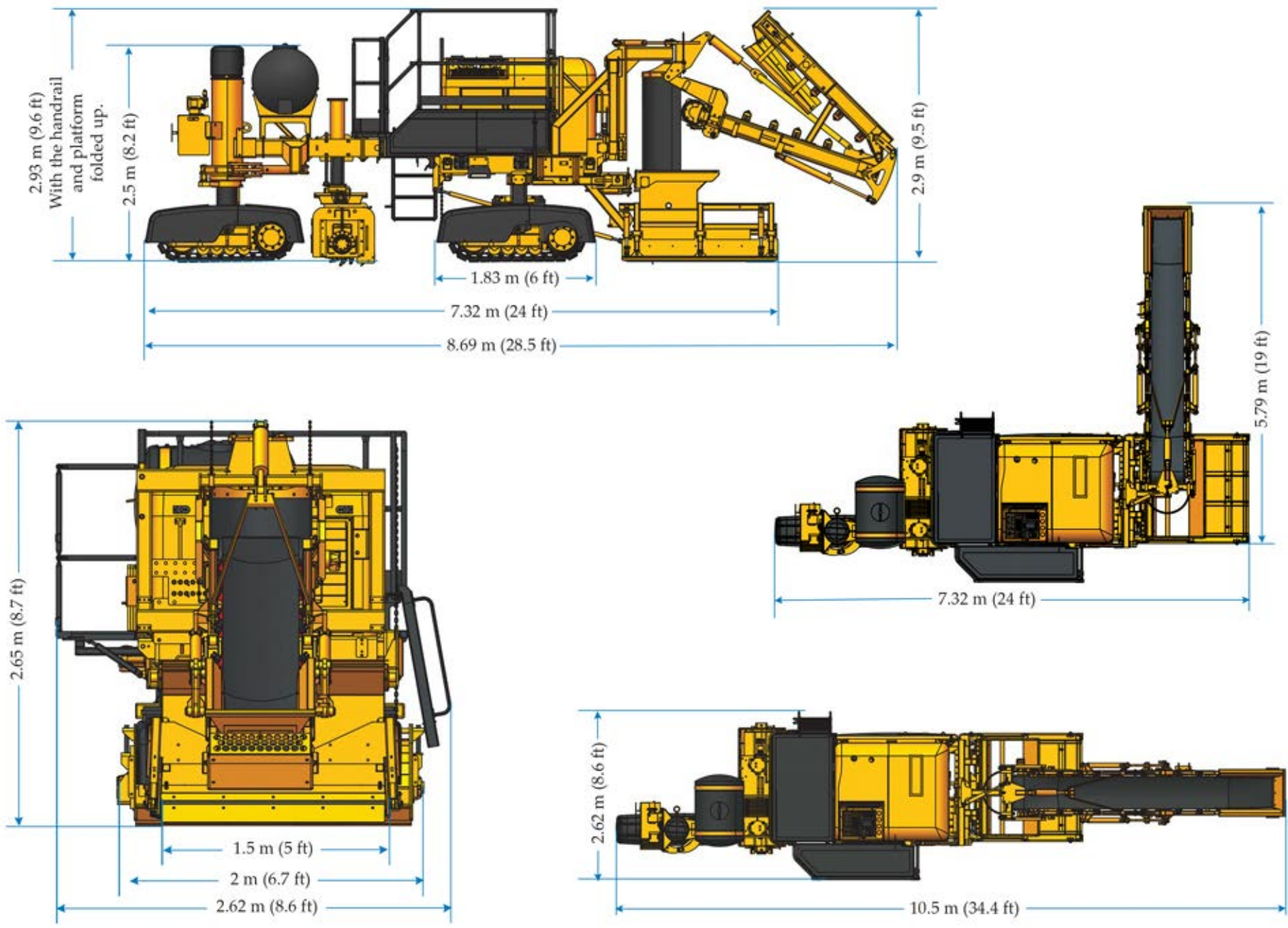

GT-3200 Sidewalk Paver with Aggregate Base Mold

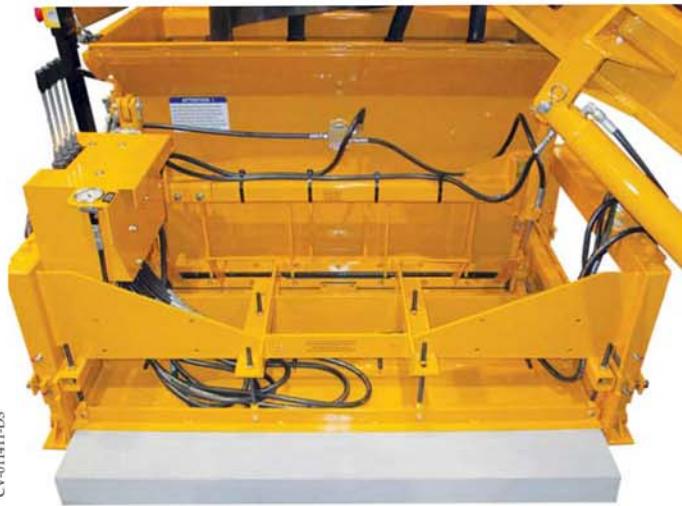
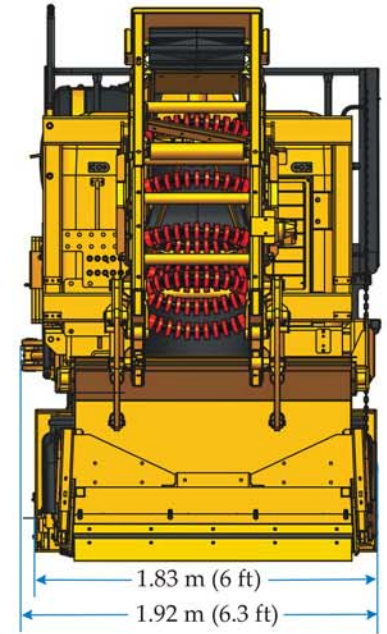
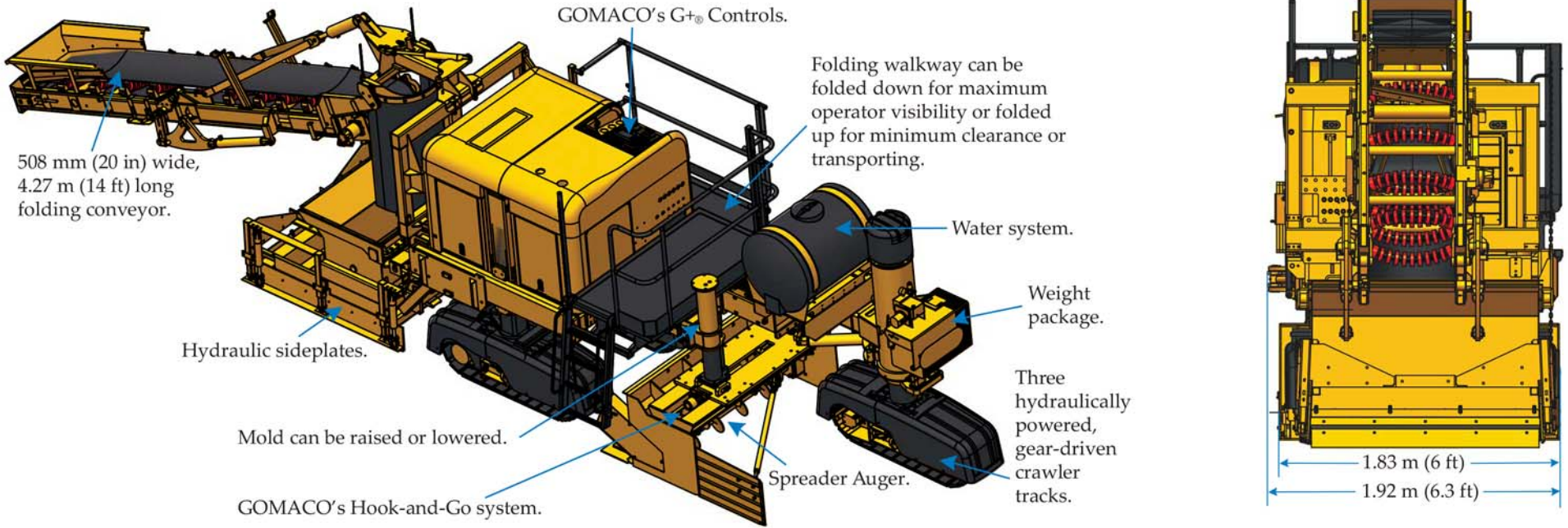

CV-011411-03

The mold on the GT-3200 sidewalk paver can be equipped with a hydraulic bar inserter and pressure-compensated sideplates.



CG-101321-03

An aggregate base mold prepares the grade and features a spreader auger. The aggregate material is placed in front of the machine and the auger spreads the material the width of the mold. The trailing pan features three pan vibrators for the initial compaction of the base material.

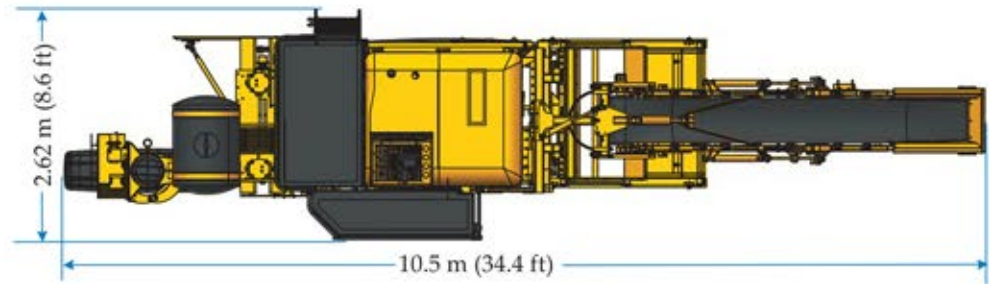
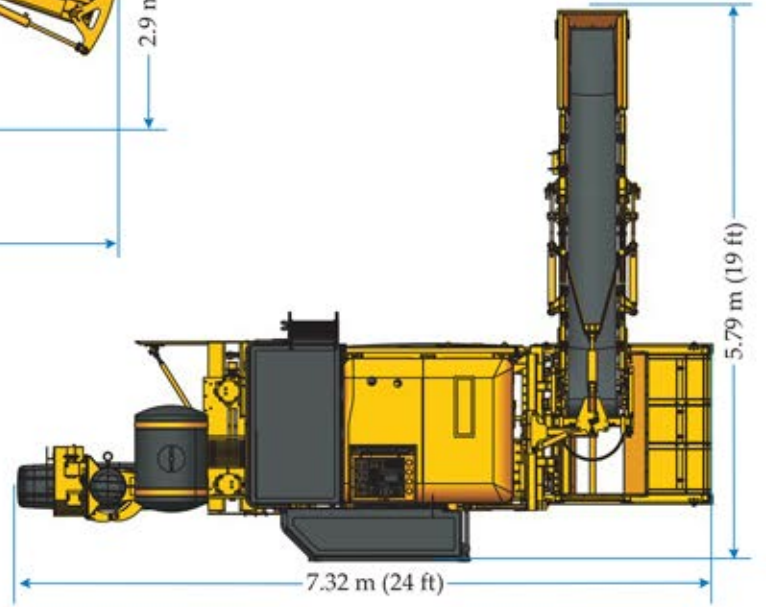
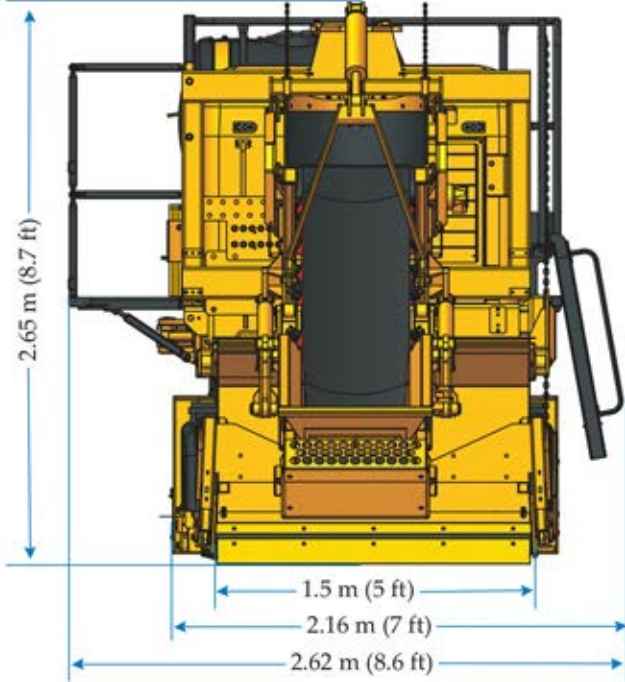
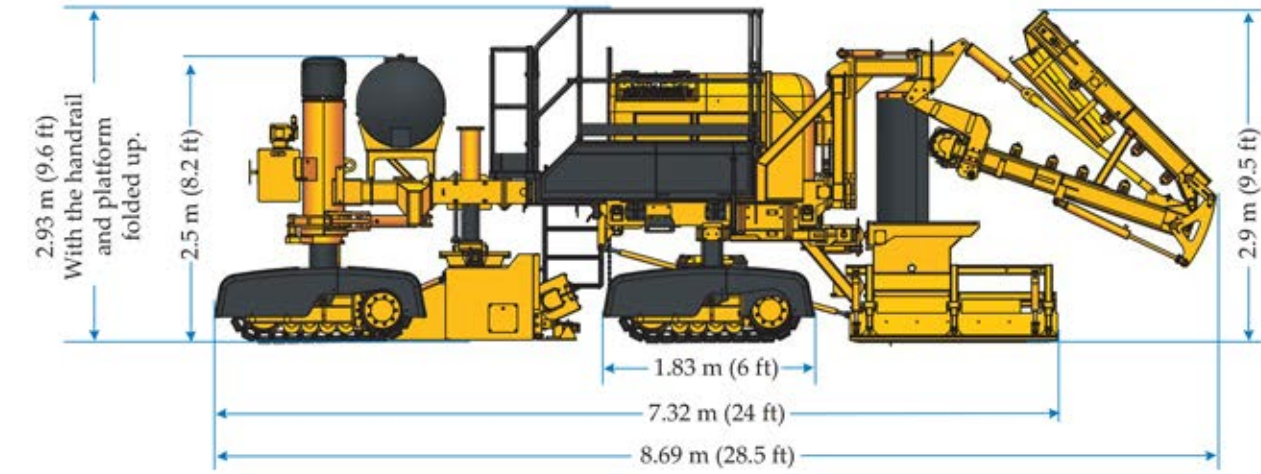



CG-071306-D10

The GT-3200 sidewalk paver is specifically designed for sidewalks and minimum clearance projects. The GT-3200 is slipforming a three meter (10 ft) wide sidewalk.



CG-111304-D1

The GT-3200 sidewalk paver slipforms a 1.5 meter (5 ft) wide sidewalk through a future housing development.

Front Cover: CG-111307-D5

MANUFACTURED UNDER ONE OR MORE OF THE FOLLOWING U.S. OR FOREIGN PATENTS: 5,190,397; 5,209,602; 5,924,817; 5,941,659; 6,099,204; 6,450,048; 2,211,331; 2,069,516; 7,044,680; 7,284,472; 7,517,171; 7,845,878; 7,850,395; 2,591,177; AND PATENTS PENDING.

GOMACO and G+ are registered trademarks of GOMACO Corporation.

GOMACO Corporation reserves the right to make improvements in design, material, and/or changes in specifications at any time without notice and without incurring any obligation related to such changes. Performance data is based on averages and may vary from machine to machine.

Printed in U.S.A. © 2014 (04 Printco 5000) GOMACO Corp.
GOMACO Corporation Order #0399-0A10439

Worldwide Headquarters
GOMACO Corporation
PO Box 151
Ida Grove, IA USA 51445
Ph: 1-712-364-3347
www.gomaco.com
E-mail: info@gomaco.com

European Headquarters
GOMACO International Ltd.
is located in Witney, England.

GOMACO has a worldwide distributor network for sales and service.



SF-081303-D7

The GT-3200 sidewalk paver can be shipped fully assembled on one truck with the aggregate base mold or trimmerhead. The conveyor can be folded up for transport.

GT-3200 Available With All-Track Steering



Stringline Steer Mode - This mode is selected when steering is to be controlled by the steering sensors. With the machine on line and in automatic steer, the operator walks the machine in reverse to the existing sidewalk, utilizing the Reverse Steer feature. Then, flipping the switch to forward steer, the operator starts to slipform.

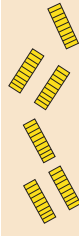

Coordinated Steer - For minimum turning radius. When the steer select switch is in the Coordinated Steer position, the steering control dial will control the turning of the tracks. When the dial is in the center position, the tracks will be straight ahead. If the dial is turned left or right from the center position, the leading track will turn in the corresponding direction and the trailing track will turn in the opposite direction.



Crab Steer - Walks sideways for ease in putting the machine on line. When the steer select switch is in the Crab Steer position, the steering control dial will control the turning of the tracks. If the dial is turned left or right from the center position, all tracks will turn in the corresponding direction to walk the machine sideways.



Front Steer - When the steer select switch is in the Front Steer position and the steering control dial is turned left or right from the center position, the front track will turn in the corresponding direction and the rear tracks will remain straight.

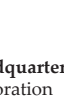

Rear Steer - When the steer select switch is in the Rear Steer position and the steering control dial is turned left or right from the center position, the rear tracks will turn in the corresponding direction and the front track will remain straight.



The Worldwide Leader in Concrete Paving Technology



GOMACO Corporation's Quality Management System Is ISO 9001:2008 Certified By The American Systems Registrar.

Quality Policy: We Shall Meet Or Exceed Our Customers' Expectations.

