

## Low-Profile Wall Mount Cabinet *HLP Series*

### Heavy Duty UL Rated 150 lbs Weight Capacity



The Hammond Low-Profile (HLP) network/security cabinet is designed as an enclosed version of our **HLPB** Pivoting Wall Mount Rack.

Unlike similar designs from our competition, the HLP features a rail that can pivot 180 degrees for easy equipment installation and maintenance.

### Features

- **UL Listed 2416 - meets new UL requirements for wall mount cabinets.**
  - **UL rated for up to 150 lbs (68 kg) static load rating.**
- Available in three (3) depths with the ability to install an additional 4U rail.
  - Rack mounting units available in 4U, 6U and 8U.
  - Rails pivot 180 degrees for easy equipment mounting.
- Up to 29" (8U) usable equipment mounting depth (vertical).
- Front door features:
  - Louvered front door for equipment airflow.
  - Can be installed to swing open either from left or right.
  - Locking hinged top and separately locking hinged body.
- Rear wall mounting section features:
  - 3.00", 2.00", 1.38" and 1.12" conduit laser knock-outs on all sides.
    - Three (3) located top and bottom, two (2) located each side.
- Two (2) laser knockouts for optional fans located top and bottom.
- Generous cable management lances located on the rear section.
- Heavy duty keyhole for wall mounting.
- Large knockouts in rear for cable access.

### Specifications

- Body and backpan of rack is constructed of 16-gauge steel, rack rails are 14-gauge steel with punched holes for use with 10-32 clip nuts in universal EIA spacing and accommodate mounting brackets. Hinged top panel is 16-gauge steel, hinged top and door section shall be locking and is keyed the same. (Optional separately keyed lock available)
- Grounding/bonding lugs are located on top and bottom of the door and rear sections.
  - Grounding kit sold separately - **GRDKIT01** or **GRDKIT04**.
- Rugged sand-textured black powder paint (reduced fingerprints and marks).
- RoHS Compliant.
- Manufactured in North America.

### Gallery



## Accessories

- Grill Fan Kits
- Hook and Loop Roll
- Outlet Strips
- Two Post Mounting Clamping Shelf
- Ground Wire Kits
- 10-32 Mounting Screw and Clip Nut Combo-Pack
- Universal Rack Shelf

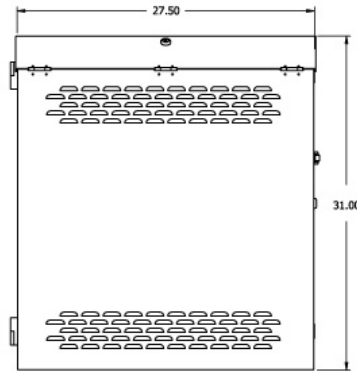

FRONT VIEW

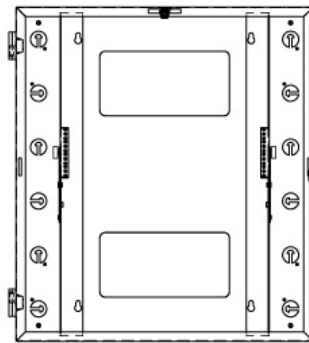

FRONT VIEW  
(DOOR REMOVED)

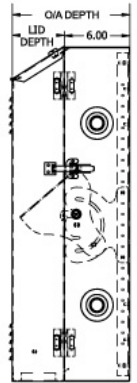

SIDE VIEW

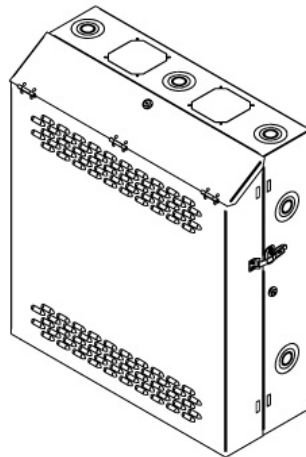

PERSPECTIVE VIEW

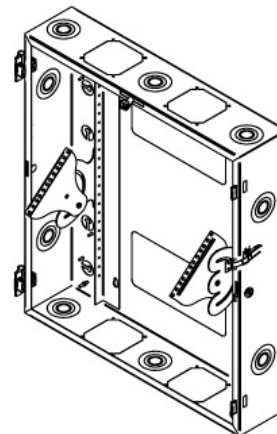

PERSPECTIVE VIEW  
(DOOR REMOVED)

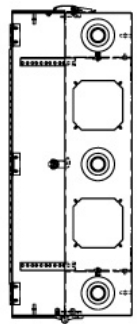

TOP/BOTTOM  
VIEW

Part No.	Overall Dimensions			Rack Units	Horizontal Usable Depth	Vertical Usable Depth
	Height	Width	Depth			
HLP4UBK	31.00	27.50	10.80	4U	7.00	29.00
HLP6UBK	31.00	27.50	15.05	6U	10.50	29.00
HLP8UBK	31.00	27.50	19.30	8U	14.00	29.00

## Additional Optional Mounting Rail Kits

<b>Part No.</b>	<b>Mounting Dimensions</b>			<b>Rack Units</b>
	<b>Height</b>	<b>Width</b>	<b>Depth</b>	
<b>HLP4UR</b>	7.00	19.00	29.00	4U
<b>HLP6UR</b>	10.50	19.00	29.00	6U
<b>HLP8UR</b>	14.00	19.00	29.00	8U

*Data subject to change without notice*

© 2017. Hammond Manufacturing Ltd. All rights reserved.