

# 6442 Large Push Button

# herga

Technology Ltd

- Choice of button/escutcheon materials
- Choice of colours
- Choice of tube options
- Large air volume for longer tube lengths



## Reference dimensions

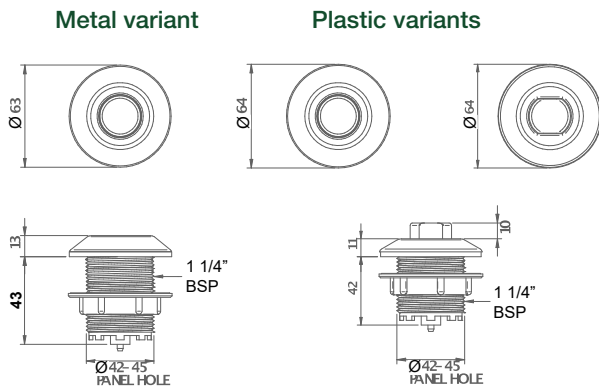

## Ordering and options

Stock models : 6442-BAAA-A000  
6442-BCCA-A000

6442 - [ ] [ ] [ ] [ ] - [ ] [ ] [ ]

### Model

Button type - please see note below

- A Flush double D button
- B Raised double D button (10 mm High)
- C Extended double D button (16 mm High)
- D Flush round button
- E Raised round button
- Z No button required

### Button finish - please see note below

- A White
- B Brilliant white
- C Chrome
- D Gold
- F Black
- G Red
- M Grey plate
- N Chrome plated brass
- P Stainless steel
- Z None supplied

### Escutcheon finish -

please see note below

- A White
- B Brilliant white
- C Chrome
- D Gold
- F Black
- G Red
- M Grey plate
- N Chrome plated brass
- P Stainless steel
- Z None supplied

### Bellows option

- A Bellows - Ø4 mm spout to suit 2311-01/08 tube
- B Bellows - Ø2 mm spout to suit 2311-03 tube
- Z No bellows required

### Nut & washer option

- A Supplied with nut & washer
- Z No nut & washer required

Note: Finish option 'P' stainless steel can only be supplied as a flush button  
For vandal resistant version, order 6443-0001, similar to 64442-DPPA-A000 (stainless)  
Button type 'D' - metal and non-plated versions only  
Button type 'E' - Plastic non-plated versions only

## General specifications

Standards/approvals	n/a
Degree of protection	EN 60529 IPX4
Connection method	Via back entry spout, 4mm dia. or 2mm dia.
Electrical rating	n/a
Contact configuration	See table
Pressure range	Compatible with 6871, 6872, 6773, 6753, 6891, 6893, 6861, 6862, 6863, 6864, 6869 - dependent on tube length

Operating temperature range	-10°C to +40°C
Body material	Thermoplastic
Weight	Plastic - 0.063Kg; metal - 0.2Kg
Additional information	Available as a vandal resistant version 6443



Herga Technology Ltd - Northern Way - Bury St. Edmunds - Suffolk - IP32 6NN - UK  
sales@herga.com • www.herga.com • +44 (0)1284 701422

Subject to change without notice