

# 6241-0058 6-Pedal Bellows Footswitch/Palm Switch

# herga

Technology Ltd

**CE** <sup>®</sup> **US**

- Multi-pedal footswitch, 6- pedal version
- Compact for discrete placement beneath equipment, or for storage
- Robust but aesthetic design
- Soft touch buttons with a light operating force
- Ideal for motion control applications

The 6241-0058 6-Pedal Bellows Footswitch/Palm Switch is supplied with 6 x blue plain domed buttons. The switch is supplied with curly coil cable and an 8 pin din plug. It has IPX7 rating and is designed for operation at 12 V DC at 50 mA.



## Reference dimensions

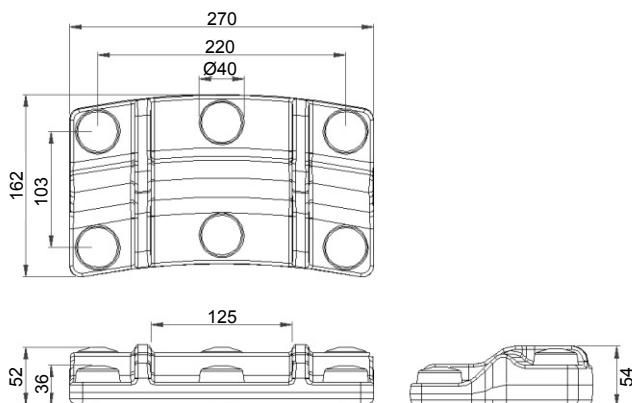

## General specifications

|                       |   |                             |   |
|-----------------------|---|-----------------------------|---|
| Standards/approvals   | UL 60601-1 File No. E 207181, IEC 60601-1 | Operating temperature range | +10°C to +50°C                                |
| Degree of protection  | EN 60529 IPX7                             | Body material               | Thermoplastic                                 |
| Connection method     | Curly coil cable with 8 Pin DIN connector | Weight                      | 1.0 kg  |
| Electrical rating     | 50mA 12V DC                               | Additional information      | choice of colours, logos and labels available |
| Contact configuration | SPST N/O                                  |                             |   |