

6240 Footswitch

herga

Technology Ltd

- Ideal for hand or foot operation
- Tough flexible cover
- Choice of colours (others available)
- Change over contact variant
- Available with plastic base plates for added stability or permanent fixing or additionally with anti-slip rubber or foam pads



Reference dimensions

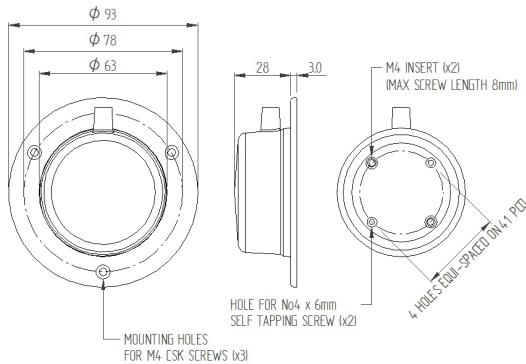

Ordering and options

Stock models : 6240-AFAA-ZA00
6240-DFAA-ZA00

6240 - [] [] [] [] - [] [] [] [] [] []

Model

Colour option -

- | | |
|---------|-------------|
| A Black | D Red |
| B Grey | E Brown/Tan |
| C White | F Green |

Mounting option -

- | | |
|--|--|
| C No mounting plate but with M4 inserts fitted | G Black plastic plate without mounting holes |
| D Grey plastic plate with mounting holes | H Chrome plated plastic plate with mounting holes |
| E Grey plastic plate without mounting holes | J Chrome plated plastic plate without mounting holes |
| F Black plastic plate with mounting holes | Z No mounting plate or inserts supplied |

Contact configuration

- | | |
|------------|-------------------------------|
| A SPST N/O | C SPCO (3-core cable minimum) |
| B SPST N/C | |

Cable length

- | | |
|------|-------|
| A 2m | C 5m |
| B 3m | D 10m |

IP40 cordset rating

- | | |
|---|---|
| A 3A 24V AC/DC, 2-core black cable, silver contacts | F 0.1A 24V AC/DC, 3-core black cable, gold contacts |
| C 0.1A 24V AC/DC, 2-core black cable, gold contacts | Z No option chosen |
| D 3A 24V AC/DC, 3-core black cable, silver contacts | |

IP67 cordset electrical rating

- | | |
|---|---|
| A 3A 24V AC/DC, 2-core black cable, silver contacts | F 0.1A 24V AC/DC, 3-core black cable, gold contacts |
| C 0.1A 24V AC/DC, 2-core black cable, gold contacts | Z No option chosen |
| D 3A 24V AC/DC, 3-core black cable, silver contacts | |

General specifications

Standards/approvals	Low voltage directive 2014/35/EU	Operating temperature range	-5°C to +40°C
Degree of protection	EN 60529 IP67 (IP68 upon request)	Body material	Thermoplastic
Connection method	Stripped cable cores or connector of your choice	Weight	0.25 kg
Electrical rating	SPST N/O, SPST N/C, SPCO	Additional information	250V AC versions available upon request Non mounting hole versions supplied with foam pad
Contact configuration	See table below		
Pressure range	n/a		



Herga Technology Ltd - Northern Way - Bury St. Edmunds - Suffolk - IP32 6NN - UK
sales@herga.com • www.herga.com • +44 (0)1284 701422

Subject to change without notice