

6251 Heavy Duty Footswitch

herga

Technology Ltd

- Sturdy durable industrial footswitch
- Stylish ergonomic design
- Available in many different colors
- Customer colours and logos available on request
- Special designs according to customer specifications
- Guard with plenty of room for safety shoes
- Waterproof EN 60529 IP 67 (IP 68 on request)
- Coupling with self-lifting plates for cable to 2 x 2.5mm²
- Available ready with cable and connector



Reference dimensions

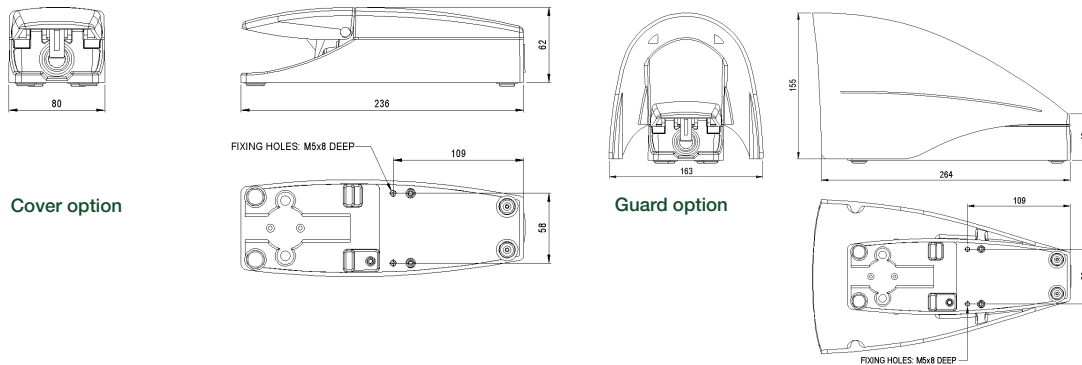

Ordering and options

6251- [] [] [] A - [] [] Z 0

Model

Cover and guard colours

- | | |
|----------------|----------------|
| A Cover Yellow | B Guard Yellow |
| C Cover White | D Guard White |
| E Cover Blue | F Guard Blue |

Other colours available subject to MOQ – contact sales for details

Base colour

- | | |
|---------|---------|
| A Black | B White |
|---------|---------|

Thread/Hole information

- | |
|--|
| A M20 Rear hole |
| B PG 13.5 Rear hole |
| C PG 13.5 Rear hole with double M20 side holes |
| D PG 13.5 Rear hole with double PG 13.5 side holes |

Tread colour

- | |
|---------|
| A Black |
|---------|

Action/Electrical rating

- | | |
|----|--|
| AA | Single Operation, Slow Break & Make ; AC-15 6A 250V ; DC-13 6A 24V |
| BB | Single Operation, Snap Break & Make ; AC-15 6A 250V ; DC-13 6A 24V |
| CB | Latching, Snap Break & Make ; AC-15 6A 250V ; DC-13 6A 24V |
| DB | Double Operation, Snap Break & Make ; AC-15 6A 250V ; DC-13 6A 24V |
| EA | Double Operation, Slow Break & Make ; AC-15 6A 230V ; DC-13 6A 24V |
| FE | SPCO + SPCO Staggered Snap Single Break, V3 ; 21A 250V AC |
| FF | SPCO + SPCO Staggered Snap Single Break, V3 ; 0.1A 250V AC |
| FG | SPCO + SPCO Staggered Snap Single Break, V3 ; 25A 250V AC |
| GE | DPCO Snap Single Break, V3 Silver Contacts ; 21A 250V AC |
| GF | DPCO Snap Single Break, V3 Gold Contacts ; 0.1A 250V AC |
| GG | DPCO Snap Single Break, V3 Silver Contacts ; 25A 250V AC |

Emergency stop

- | | |
|---|--------------------------|
| Z | No emergency stop fitted |
|---|--------------------------|

Double pedal versions with/without guard available, to find out more, talk to our sales department.



Herga Technology Ltd - Northern Way - Bury St. Edmunds - Suffolk - IP32 6NN - UK
 sales@herga.com • www.herga.com • +44 (0)1284 701422

Subject to change without notice

6251 Heavy Duty Footswitch

herga

Technology Ltd

General specifications

Standards/approvals	EN60204-1 with switching to meet EN60947-5-1, VDE 0660 pt 200, IEC 947-5-1	Operating temperature range	-25°C to +60°C
Degree of protection	EN 60529 IP67 (IP68 upon request)	Body material	Die cast aluminium
Connection method	Internal terminal block, cabled versions available upon request	Weight	Cover/unguarded 1Kg or 1.5Kg guarded
Electrical rating	See ordering & options	Average mechanical life	1 x 10 ⁶ operations
Contact configuration	See ordering & options	Additional information	The electrical housing has an environmental rating of IP67. To achieve this, a minimum torque of 1.7N should be applied to the two enclosure screws

Switch specifications

	Options A&B in Electrical rating section						Options H&J in Electrical rating section	
Rated operating voltage	500V AC, over 380V AC same potential only							
Rated operational current	AC 40 - 60 Hz				DC		AC 50 - 60 Hz	
	Le/AC-12	Ue	Le/AC-15	Ue	Le/DC-12	Le/DC-13	Ue (V)	Le/AC-15 (A)
	(A)	(V)	(A)	(V)	(A)	(A)		
	10	24	10	24	10	10	230	3
	10	125	10	48	6	4		
	10	230	6	110	4	1		
	10	400	4	220	1	0.4		
	10	500	3	440	0.5	0.2		

Limit switches also available with Gold contacts

Note: When the footswitch is supplied with a pre-wired cordset, the cordset rating takes precedence over the footswitch rating. The rating will be marked on the cordset

Electrical Life Expectancy at Category AC-15	0.5 X 10 ⁶ switching cycles when interrupting 6A AC-15 at 250V			
Contact configuration	Normally open + normally closed positive opening operation to EN 60947-5-1			
Contact Gap	>3mm, suitable for mains isolation			
Terminals	Screw terminals and self-lifting clamp for connection of flexible leads min. 2 x 1.5 mm ² - max. 2 x 2.5 mm ²		Screw terminals for connection of flexible lead wire min. 1 x 0.5 mm ² - max. 2 x 2.5 mm ²	
Action Type from Order Code	A	B	D	E
Limit switch action	1 Pole Slow Make Slow Break	1 Pole Snap Action	2 Pole Snap Action	2 Pole Slow Make Slow Break

In all applications except where protective extra low voltage (PELV) circuits are being switched, an earth conductor must be installed. The earth conductor should be rated in accordance with the prevailing standards.

Microswitch standards: EN 60730, EN 61058
Microswitch Approvals: ENEC, CSA, UL

21A microswitch				
Average life expectancy	Mechanical	1.0 X 10 ⁶		
	Electrical	2.0 X 10 ⁵ @ 10A	1.0 X 10 ⁴ @ 21A	
Max. electrical load				
	Voltage (V)	Resistive (A)	Inductive (A)	Motor (Pf0.75)
AC	250V	21A		2HP
	250V	21A		1HP
	125V	21A	8A	
DC	6V	21A	21A	
	12V	15A	15A	
	24V	8A	7A	
	60V	1A	0.5A	
	110V	0.5A	0.2A	
	220V	0.25A	0.1A	

25A microswitch				
Average life expectancy	Mechanical	1.0 X 10 ⁶		
	Electrical	1.0 X 10 ⁵ @ 1.0A		
Max. electrical load				
	Voltage	Resistive (A)	Inductive (A)	Motor (Pf0.75)
AC	250V	25A		2HP
	250V	25A		2HP
UL/CSA	125V	25A		1HP

Gold contact microswitch				
Average life expectancy	Mechanical	1.0 X 10 ⁶		
	Electrical	2.0 X 10 ⁵ @ 0.1A		
Max. electrical load				
	Voltage	Resistive (A)	Inductive (A)	Motor (Pf0.75)
AC	250V	0.1A		
UL/CSA	125V	0.1A	0.05	N/A

Note Dry Switching: These switches must be used for low power circuits i.e. low current (4 to 100 mill amperes) and low voltage (below 30V), consult herga for further advice.

Contact configuration

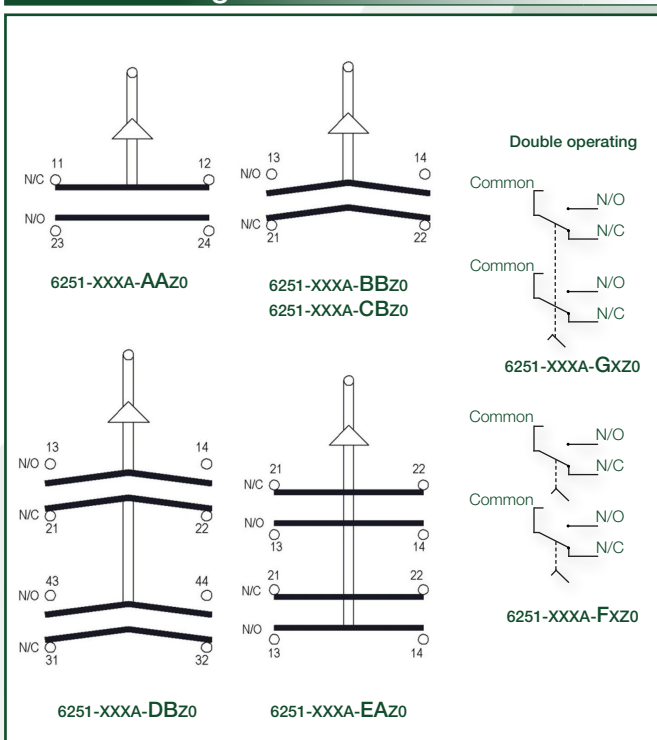

Herga Technology Ltd - Northern Way - Bury St. Edmunds - Suffolk - IP32 6NN - UK
sales@herga.com • www.herga.com • +44 (0)1284 701422

Subject to change without notice