

# 6254 General Industrial Footswitch

# herga

Technology Ltd

- Powder coated body/base die cast aluminium, its toughness and modest cost make it ideal for OEM applications
- Optional powder coated mild steel guard
- Pneumatic version available, please refer to Airswitching section for details
- Customer colours and logos available on request
- Ideal for remote switching in harsh environmental conditions where durability is required

## Reference dimensions

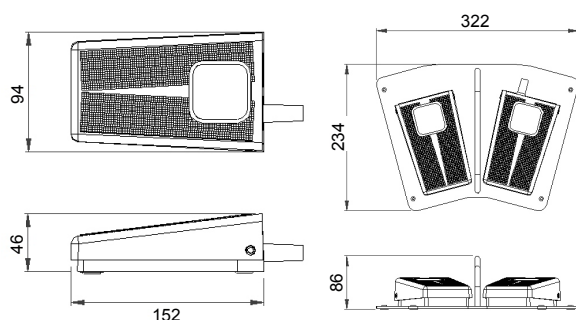

## General specifications

<b>Standards/approvals</b>	footswitch: low voltage directive 2006/95/EC, EN 60950 microswitch: EN 61058-2-1, EN 61058	<b>Operating temperature range</b>	-5°C to +40°C
<b>Degree of protection</b>	EN 60529 IPX2, IPX7 (IPX8 upon request)	<b>Body material</b>	Die cast aluminium
<b>Connection method</b>	Stripped cable cores or connector of your choice	<b>Weight</b>	See table below
<b>Electrical rating</b>	See table below	<b>Additional information</b>	Cordset variations of each standard option are available (6254-DO and DA versions can be built with cordset)
<b>Contact configuration</b>	See table below		

## 6254 - Range options and specifications

	Stock model				
Model No	6254-CT	6254-CC	6254-DO	6254-DA	6254-WO
Weight approx.	0.475Kg	0.475Kg	0.475Kg	0.525Kg	0.525Kg
Optional black guard	18 SWG mild steel, powder coat				
No. of poles	SPCO	SPCO	DPCO	DPCO staggered	SPST N/O
Cable	Terminal block	3-core + earth	Terminal block	Terminal block	3-core + earth
Cable length as Std	n/a	2m	n/a	n/a	2m
Cable O/D (mm)	n/a	7.5 (nom.)	n/a	n/a	6.8 (nom.)
Current rating @ 250V AC	6(3)A	6 (3)A	6 (3)A	6 (3)A	6 (1.5)A
Internal switch module	IPX2	IPX2	IPX2	IPX2	IPX7