

6210 Light Industrial Duty Footswitch

herga

Technology Ltd

- Economic/versatile plastic switch designed to reduce operator fatigue
- Pneumatic version available, please refer to Airswitching section for details
- Ideal for repetitive use with office equipment, domestic/medical appliances and general industrial applications
- Customer colours and logos available on request

Reference dimensions

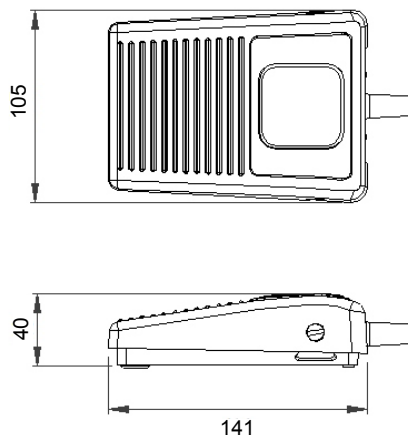

General specifications

Standards/approvals	footswitch: low voltage directive 2014/35/EU, EN 60950 microswitch: EN 61058-2-1, EN 61058	Operating temperature range	-5°C to +40°C
Degree of protection	EN 60529 IPX2, IPX7 (IPX8 upon request)	Body material	Thermoplastic
Connection method	Stripped cable cores or connector of your choice	Weight	See table below
Electrical rating	See table below	Additional information	Cordset variations of each standard option are available (IPX8 upon request) Note: models 6210-CC & 6210-DO contain an unconnected earth wire.
Contact configuration	See table below		

6210 - Range options and specifications

	Stock model					
Model No	6210-CC	6210-ST	6210-SC	6210-WO	6210-DT	6210-DO
Weight approx.	0.375Kg	0.35Kg	0.375Kg	0.375Kg	0.35Kg	0.375Kg
Material: body	Thermoplastic					
Optional black guard	18 SWG mild steel, powder coat					
No. of poles	SPCO	SPCO	SPST N/O	SPST N/O	DPST N/O	DPST N/O
Cable	4 core	Terminal block	2 core	2 core	Terminal block	5 core
Cable length as Std	2m	n/a	2m	2m	n/a	2m
Cable O/D (mm)	6.8 (nom)	n/a	6.8 (nom)	6.8 (nom)	n/a	6.8 (nom)
Current rating @ 250V AC	3A (1.5)	6A (3)	6A (3)	6A (3)	6A (3)	3A (.5)
Internal switch module	IPX2	IPX2	IPX2	IPX7	IPX2	IPX2