

PRODUCT CATALOG

Hergo.com Reference Book • 2014



ENCLOSURE CABINETS

TECHNICAL WORKSPACE SOLUTIONS
WWW.HERGO.COM | 888.222.7270





YOUR trusted Technical Workspace Solutions since 1992

- Command Centers
- Data Centers
- IT Furniture
- Workstations
- Tech Workbenches
- Mobile Carts
- Enclosure Cabinets
- Relay Racks



Control Rooms



Corner Workstations



PACS Workstations



Motorized Height Adjustment

Height Adjustable Workstations



Mobile Post Carts



Wall Mount Cabinets



Enclosures / Cabinets



19" Relay Racks



Technical Workbenches

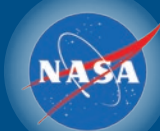

ENCLOSURE CABINETS

User Flexibility and Compatibility
Standard design allows for mounting of all computers and electronic equipment that meets E.I.A. Specifications. Hergo enclosures are compatible with most standard rack mount servers.

ENCLOSURE CABINETS

Configuring YOUR Enclosure

Use the Model Menu below to determine which enclosure unit meets your requirements. Go to the appropriate page as shown on the bottom row of the menu to locate the enclosure of your choice. All compatible options and accessories will be presented on this page to assist you in configuring your enclosure.

Choose from the following items:

1. Side Panels
2. Front and Rear Doors
3. Fixed and/or Slide-Out Shelves
4. Fan Assemblies and Air Filters
5. Cable Management
6. Power Management
7. Gliders, Stabilizers or Casters
8. Additional Options



MODEL MENU*		WALL MOUNT		SATURN		MARS		APX SERVER					
		SINGLE	DOUBLE										
Model	Z4238	Z-LINE12	Z-LINE 6	SATURN	SATURN30	MARS	MARS30	MERCURY	DESKMATE30	APX SERVER	APX SERVER	APX SERVER	
Description	38" D	21.63" D	17" D	36" D	30" D	Mid-Size	Mid-Size	Under-Desk	30" D	26U	12U	42U	
Height	Inside U	42 U	12 U	6 U	42 U	42 U	26 U	26 U	12 U	12 U	26 U	12 U	42 U
	Inside Inches	73.50"	21"	10.50"	73.50"	73.50"	45.50"	45.50"	21"	21"	45.50"	21"	73.50"
Depth	Inside	UP TO 34"	UP TO 15" / 18"	UP TO 15" / 18"	UP TO 34"	UP TO 28"	UP TO 34"	UP TO 28"	UP TO 34"	UP TO 28"	UP TO 34"	UP TO 34"	UP TO 34"
	Outside	38"	UP TO 17.7" / 21.63"	UP TO 17.7" / 21.63"	36"	30"	36"	30"	36"	30"	36"	36"	38"
Width	Inside	19"	19"	19"	19"	19"	19"	19"	19"	19"	19"	19"	19"
	Outside	23"	23.62"	23.62"	24"	24"	24"	24"	24"	24"	24"	24"	23"
Overall Height	Plain Height	77.50"	25"	14.50"	78.75"	78.75"	50.50"	50.50"	26.25"	26.25"	50.50"	26.25"	77.50"
	With Gliders	78.50"	-	-	79.50"	79.50"	51.25"	51.25"	27.00"	27.00"	51.25"	27.00"	78.50"
	With 2.75" H Casters	80.50"	-	-	81.50"	81.50"	53.25"	53.25"	29.25"	29.25"	53.25"	29.25"	80.50"
	With 4" H Casters	82.50"	-	-	83.75"	83.75"	55.50"	55.50"	30.25"	30.25"	55.50"	30.25"	82.50"
Find it On PAGE		14	15	16	18	20	22	24	26	28	29		

MADE IN NEW YORK

HEIGHT 42 U

WIDTH 23"

DEPTH 38"

Hergo Z4238 Enclosure Cabinet

95-Z4238-000



Removable Lockable Louvered Side Panels

Dimensions:

External: W-23" x D-38" x H-77.50"

Internal Mounting Dimensions:

Height 42U / 73.50"
Depth 34"

Heights:

Floor Mounted 77.50"
With Gliders 78.50"
With Industrial Casters 80.50"
With Institutional Casters 82.50"

Swing Handle Lock

Upgrade Available with Combination (as Shown)

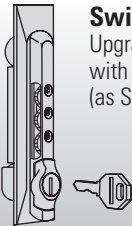

Package Includes:

4 Z Style Mounting Rails

Rails are number marked for every "U" of rackmount space from 1 to 42U.

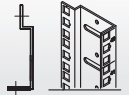

Cable Management

Supplied with 8 cable management loops (4 on each side). Holds approximately 100 Cat 5 cables.

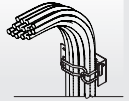

Brush Insert Cable Thruway

Supplied with 1 Brush Insert to manage cable access and protect from dust and debris.

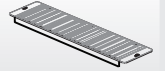

Casters

Supplied with 4 Dual-Wheel Casters (2 Locking and 2 Non-locking).



2 Removable, Lockable, Louvered Side Panels

Front & Rear Doors - User Choice (see below)

Screws & Cage Nuts - Bag of 20 each

Options:

Fan Assemblies and Cover Plates

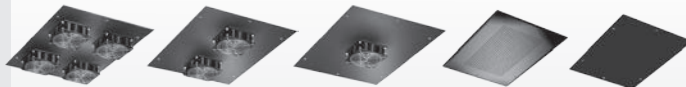

4 Fans Quiet 300 CFM	2 Fans Quiet 150 CFM	1 Fan Quiet 75 CFM	1 Fan 606 CFM	Perforated	Solid
----------------------------	----------------------------	--------------------------	------------------	------------	-------

Shelves

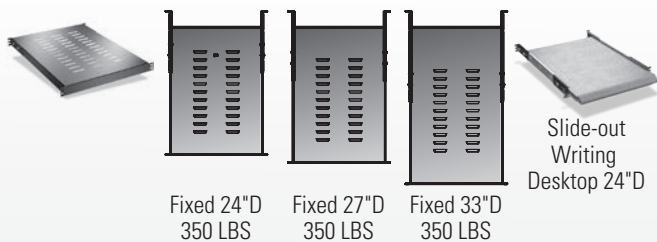

Fixed 24"D 350 LBS Fixed 27"D 350 LBS Fixed 33"D 350 LBS

Slide-out Writing Desktop 24"D



Slide-out 24"D 100 LBS Slide-out 27"D 135 LBS Slide-out 33"D 135 LBS Slide-out Mini Keyboard Shelf 24"D Slide-out Full Size Keyboard Shelf 24"D

Front & Rear Doors

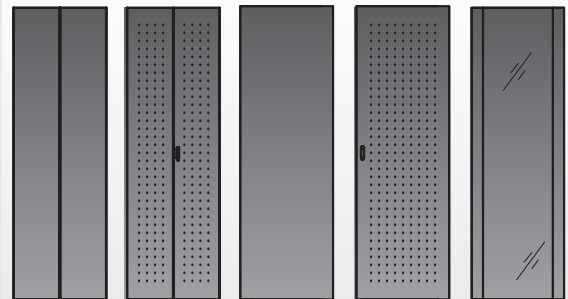

Split-Solid Split-Perf. Solid Perforated Glass

Accessories



Power Strip 6-Port, 15-Amp Wire Loop Panel Metal, 1U Internal Lighting Rackmountable Lifting Lugs (set of 4) Screws/Cage Nuts

Filler Panels

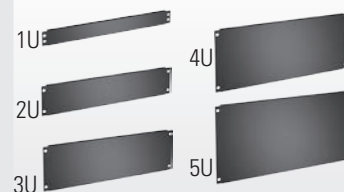

Tilt Stabilizers

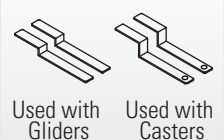

Used with Gliders Used with Casters

Hergo Z Wall Mount Cabinets

Features

Hergo Z Wall Mount Enclosure Cabinets organize and safeguard technical data and equipment at any height level without taking up valuable floor space. Standard design allows for mounting of all electronic equipment that meets E.I.A. 19" Specifications.

2 Removable Side Panels for easy access to equipment and cabling.

Brush Insert Cable Thruway Supplied with 1 Brush Insert to manage cable access and protect from dust and debris.

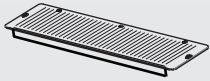

6U

Wall Mount Enclosure 6U - Single Section

24-14900-006

Optional Quiet Fan (75 CFM) & Filter

Mounting Dimensions: Height 6U (10.5") • Accommodates up to 15" Deep

External Dimensions: 14.5" H x 23.62" W x 17.70" D

Package Includes: (2) 6U Mounting Rails and (10) Screws & Cage Nuts

12U

Wall Mount Enclosure 12U - Single Section

24-14900-002

Optional Quiet Fan (75 CFM) and Filter

Mounting Dimensions: Height 12U (21") • Accommodates up to 15" Deep

External Dimensions: 25" H x 23.62" W x 17.70" D

Package Includes: (2) 12U Mounting Rails and (10) Screws & Cage Nuts

SINGLE

6U - Double Section

24-14902-006

Optional Quiet Fan (75 CFM) & Filter

Mounting Dimensions: Height 6U (10.5") • Accommodates up to 18" Deep Equipment

External Dimensions: 14.5" H x 23.62" W x 21.63" D

Package Includes: (4) 6U Mounting Rails and (10) Screws & Cage Nuts

12U - Double Section

24-14700-002

Optional Quiet Fan (75 CFM) and Filter

Mounting Dimensions: Height 12U (21") • Accommodates up to 18" Deep Equipment

External Dimensions: 25" H x 23.62" W x 21.63" D

Package Includes: (4) 12U Mounting Rails and (10) Screws & Cage Nuts

DOUBLE

- Mounting Dimensions:**
- External Dimensions:**
- Package Includes:**
- Static Weight Capacity:**
- Color:**
- Finish:**

Up to 100 lbs. (When evenly distributed)

Black

Powder Coat Painted - Environmentally Friendly.

Accessories:

<p>Mounting Rails</p> <p>24-14700-006 24-14700-012</p>	<p>19" Power Strip 6-Port, 15-Amp</p> <p style="text-align: center;">24-09276-000</p>	<p>19" In-Cabinet Lighting Rackmountable</p> <p style="text-align: center;">24-09280-000</p>	<p>19" Wire Loop Panel Metal, 1U</p> <p style="text-align: center;">24-09260-000</p>
<p>19" Cantilever Shelf 12" Deep</p> <p style="text-align: center;">14-00710-000</p>	<p>19" Cantilever Shelf 15" Deep</p> <p style="text-align: center;">14-00712-000</p>	<p>Quiet Fan/Filter (75 CFM)</p> <p style="text-align: center;">24-09200-004</p>	<p>Screws / Cage Nuts</p> <p style="text-align: center;">55-01170-000 (25) 55-01172-000 (50)</p>

HEIGHT **42 U** WIDTH **24"** DEPTH **36"**

SATURN Enclosure Cabinet

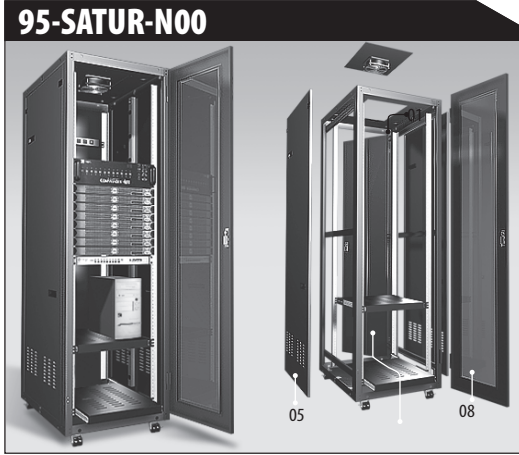

OPTIONS:

Frame, Mounting Rails, Screws & Cage Nuts

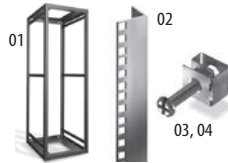

Side Panels, Front & Rear Doors

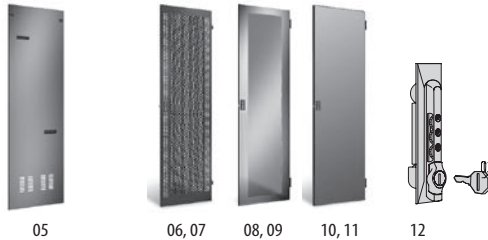

Fixed Shelves



All shelves require screws and cage-nuts for mounting in enclosure

Slide-Out Shelves



Air Filters, Fan Assemblies & Cover Plates

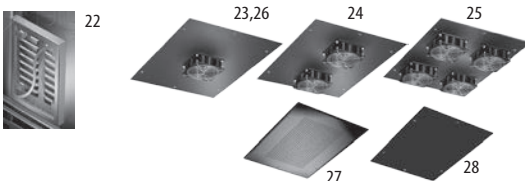

Internal Equipment	Width: 19"
Mounting Dimensions	Depth 36" : Up to 34" Deep Equipment Height: 42 U (73.5")
External Dimensions	78.75" High* x 24" Wide x 36" Deep
Static Weight Capacity	Up to 1,400 lbs. with Industrial Casters
Construction	Base & Top: Enhanced in all 4 Corners by 11- Gauge Gussets Upright Support: A 4 bend 16-Gauge design for strong vertical support Side Panels: Removable and Lockable from within the Enclosure Standard Color: Black. Quality Powder Coat Finish - Environmentally Friendly
Baying	Connect 2 or more Enclosures and eliminate the need for Side Panels
*Overall Height	Plain Height 78.75" With Gliders 79.50" With 2.75" Industrial Casters 81.50" With 4" Institutional Casters 83.75"

#	ITEM	DESCRIPTION	PART No.
01	Basic Standard Frame	24" Wide x 36" Deep	24-04302-360
02	Mounting Rails	Square Cage knock-outs (1 ea.)	24-04312-000
03	Mounting Screws	M6 x 16mm - Screws and-Cage Nuts, Bag of 25	55-01160-000
04	Mounting Screws	M6 x 16mm - Screws and-Cage Nuts, Bag of 50	55-01162-000
05	Side Panel	36" Deep, Bottom Louvered - ea.	24-04320-360
06	Front Door	Vertically Louvered, Perforated Panel, w/Handle Lock	24-04344-000
07	Rear Door	Vertically Louvered, Perforated Panel, w/Handle Lock	24-04345-000
08	Front Door	Tempered Glass with Handle Lock	24-04346-000
09	Rear Door	Tempered Glass with Handle Lock	24-04348-000
10	Front Door	Solid with Handle Lock	24-04357-000
11	Rear Door	Solid with Handle Lock	24-04358-000
12	Combination Lock	Swing Handle with Master Cylinder Key	24-04400-000
13	Fixed Shelf	24" Deep, Louvered, 350 lbs.	24-09052-000
14	Fixed Shelf	27" Deep, Louvered, 350 lbs.	24-09054-000
15	Cantilever Shelf	19" Wide, 12" Deep	14-00710-000
16	Cantilever Shelf	19" Wide, 15" Deep	14-00712-000
17	Slide-Out Shelf	24" Deep, Louvered, 100 lbs.	24-09062-100
18	Slide-Out Shelf	27" Deep, Louvered, 135 lbs.	24-09062-180
19	Slide-Out Shelf	For Mini Keyboard (13"W) & Mouse Pad	24-09080-000
20	Slide-Out Shelf	Swivel-Out Full KB with Rear Mouse Area	24-09082-000
21	Slide-Out Shelf	Slide-Out Writing Desktop, 24" Deep	24-09084-000
22	Air Filter	For 36" Deep - Sold in single units.	24-09424-000
23	Top Fan Assembly	1 Fan, 75 CFM	24-09110-000
24	Top Fan Assembly	2 Fans, 150 CFM	24-09112-000
25	Top Fan Assembly	4 Fans, 300 CFM	24-09114-000
26	Top Fan Assembly	1 Fan, 606 CFM	24-09110-006
27	Cover Plate	Top, Perforated	24-09006-000
28	Cover Plate	Bottom, Solid	24-09010-000

Specifications are subject to change without notice. Consult with a Hergo Account Executive today.

© Hergo Ergonomic Support Systems, Inc.

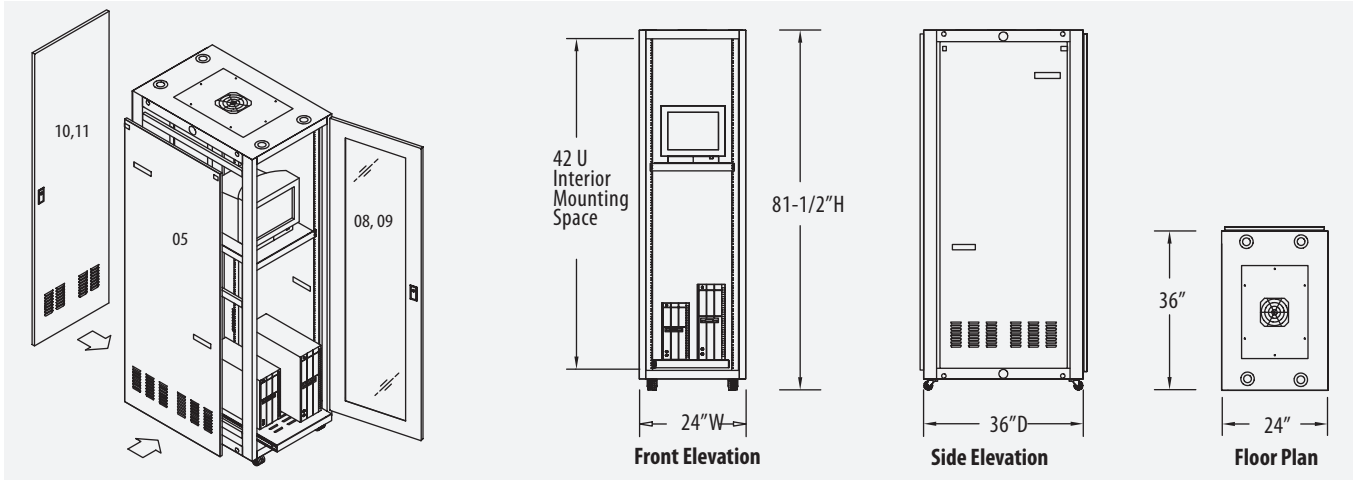

OPTIONS:

Gliders, Casters, Stabilizers



#	ITEM	DESCRIPTION	PART No.
30	Glider	Heavy Duty Glider	28-00110-000
31	Caster	Dual Width, Heavy Duty, 2.75" High	28-00010-000
32	Caster	Dual Width, Heavy Duty, 2.75" High, Lockable	28-00012-000
33	Stabilizers	Enclosure Tilt Stabilizers (2 ea.) for unit with Gliders	24-09370-000
34	Stabilizers	Enclosure Tilt Stabilizers (2 ea.) for unit with Casters	24-09372-000

Cable & Power Management



35	60" L Power Strip	12 Ports, 15 Amp, 6' Power Cord	24-09270-000
36	19" W Power Strip	6 Ports, 15 Amp, 19" Rackmountable Panel	24-09276-000
37	D - Wire Loops	Wire Loops - (Set of 10) - Mount to Rails	24-09250-000
38	Wire Loop Panel	19"W Horizontal Metal Wire Loop Panel (1 U)	24-09260-000

Hood Cover, Grommets, Lifting Lugs



39	Hood Cover	24" Wide x 36" Deep	24-09520-036
40	Small Grommet	1.5" Dia. for cable protection - for sides	24-09610-000
41	Large Grommet	2.5" Dia. for cable protection- for top	24-09614-000
42	Lifting Lugs	Set of 4 - Required for lifting enclosure	24-09350-000

Fill-in Panels

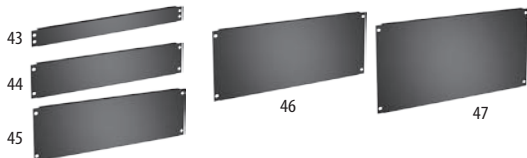

43	1 U Panel	1.75" High	24-09510-100
44	2 U Panel	3.50" High	24-09510-200
45	3 U Panel	5.25" High	24-09510-300
46	4 U Panel	7.00" High	24-09510-400
47	5 U Panel	8.75" High	24-09510-500

Lighting, Baying Kit, Mini- Keyboard



48	Internal Lighting	In-Cabinet Lighting, Rackmountable	24-09280-000
49	Baying Kit	4-Corner Assembly Kit	24-09300-000
50	Mini Keyboard	84 Keys, 13" Wide Keyboard, Black	24-09087-000
51	Mini Keyboard	84 Keys, 13" Wide Keyboard, Putty	24-09087-002

Specifications are subject to change without notice. Consult with a Hergo Account Executive today.

© Hergo Ergonomic Support Systems, Inc.

HEIGHT **42 U** WIDTH **24"** DEPTH **30"**

SATURN 30 Enclosure Cabinet

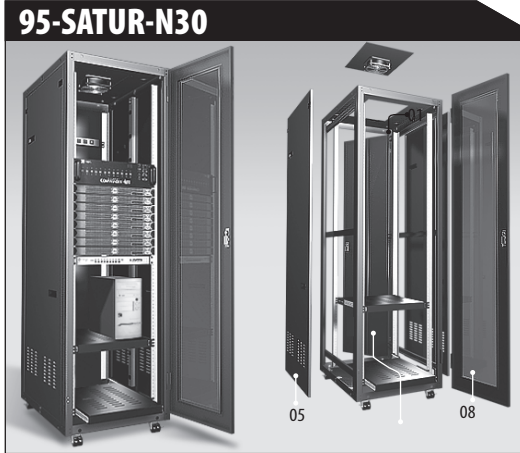

Internal Equipment	Width: 19"
Mounting Dimensions	Depth 30" : Up to 28" Deep Equipment Height: 42 U (73.5")
External Dimensions	78.75" High* x 24" Wide x 30" Deep
Static Weight Capacity	Up to 1,400 lbs. with Industrial Casters
Construction	Base & Top: Enhanced in all 4 Corners by 11- Gauge Gussets Upright Support: A 4 bend 16-Gauge design for strong vertical support Side Panels: Removable and Lockable from within the Enclosure Standard Color: Black. Quality Powder Coat Finish - Environmentally Friendly
Baying	Connect 2 or more Enclosures and eliminate the need for Side Panels
*Overall Height	Plain Height 78.75" With Gliders 79.50" With 2.75" Industrial Casters 81.50" With 4" Institutional Casters 83.75"

OPTIONS:

Frame, Mounting Rails, Screws & Cage Nuts

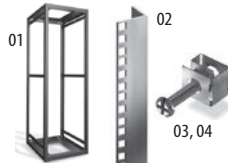

Side Panels, Front & Rear Doors



Fixed Shelves



All shelves require screws and cage-nuts for mounting in enclosure

Slide-Out Shelves



Air Filters, Fan Assemblies & Cover Plates

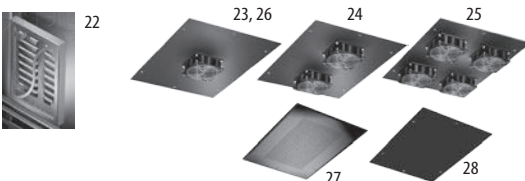

#	ITEM	DESCRIPTION	PART No.
01	Basic Standard Frame	24" Wide x 30" Deep	24-04302-300
02	Mounting Rails	Square Cage knock-outs (1 ea.)	24-04312-000
03	Mounting Screws	M6 x 16mm - Screws and-Cage Nuts, Bag of 25	55-01160-000
04	Mounting Screws	M6 x 16mm - Screws and-Cage Nuts, Bag of 50	55-01162-000
05	Side Panel	30" Deep, Bottom Louvered - ea.	24-04320-300
06	Front Door	Vertically Louvered, Perforated Panel, w/Handle Lock	24-04344-000
07	Rear Door	Vertically Louvered, Perforated Panel, w/Handle Lock	24-04345-000
08	Front Door	Tempered Glass with Handle Lock	24-04346-000
09	Rear Door	Tempered Glass with Handle Lock	24-04348-000
10	Front Door	Solid with Handle Lock	24-04357-000
11	Rear Door	Solid with Handle Lock	24-04358-000
12	Combination Lock	Swing Handle with Master Cylinder Key	24-04400-000
13	Fixed Shelf	24" Deep, Louvered, 350 lbs.	24-09052-000
14	Fixed Shelf	27" Deep, Louvered, 350 lbs.	24-09054-000
15	Cantilever Shelf	19" Wide, 12" Deep	14-00710-000
16	Cantilever Shelf	19" Wide, 15" Deep	14-00712-000
17	Slide-Out Shelf	24" Deep, Louvered, 100 lbs.	24-09062-100
18	Slide-Out Shelf	27" Deep, Louvered, 135 lbs.	24-09062-180
19	Slide-Out Shelf	For Mini Keyboard (13"W) & Mouse Pad	24-09080-000
20	Slide-Out Shelf	Swivel-Out Full KB with Rear Mouse Area	24-09082-000
21	Slide-Out Shelf	Slide-Out Writing Desktop, 24" Deep	24-09084-000
22	Air Filter	For 30" Deep - Sold in single units.	24-09414-000
23	Top Fan Assembly	1 Fan, 75 CFM	24-09110-000
24	Top Fan Assembly	2 Fans, 150 CFM	24-09112-000
25	Top Fan Assembly	4 Fans, 300 CFM	24-09114-000
26	Top Fan Assembly	1 Fan, 606 CFM	24-09110-006
27	Cover Plate	Top, Perforated	24-09006-000
28	Cover Plate	Bottom, Solid	24-09010-000

Specifications are subject to change without notice. Consult with a Hergo Account Executive today.

© Hergo Ergonomic Support Systems, Inc.

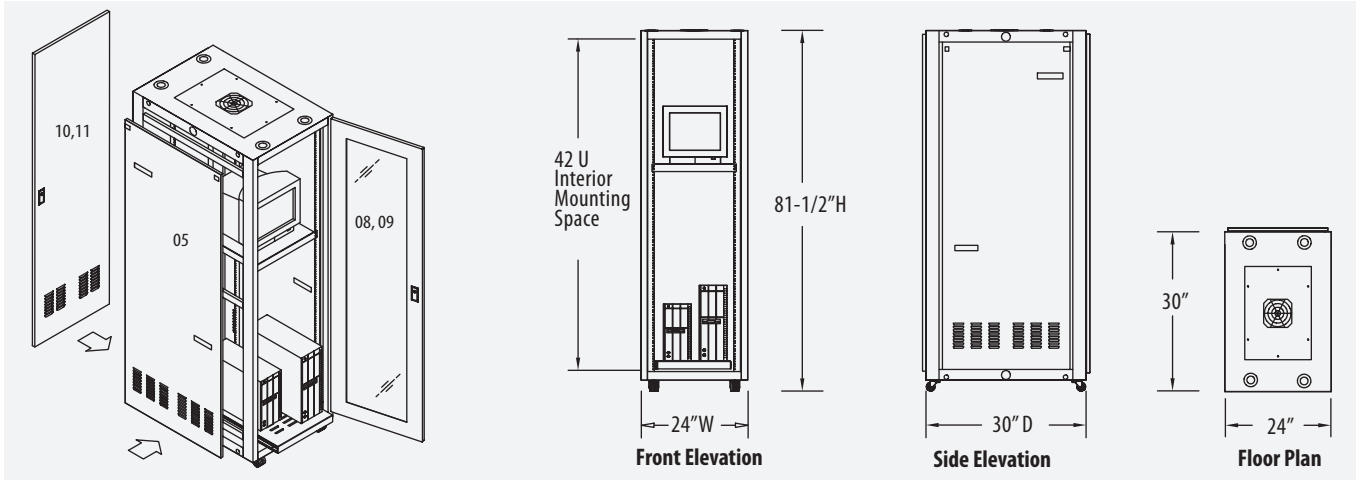

OPTIONS:

Gliders, Casters, Stabilizers

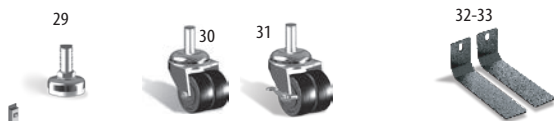

#	ITEM	DESCRIPTION	PART No.
29	Glider	Heavy Duty Glider	28-00110-000
30	Caster	Dual Width, Heavy Duty, 2.75" High	28-00010-000
31	Caster	Dual Width, Heavy Duty, 2.75" High, Lockable	28-00012-000
32	Stabilizers	Enclosure Tilt Stabilizers (2 ea.) for unit with Gliders	24-09370-000
33	Stabilizers	Enclosure Tilt Stabilizers (2 ea.) for unit with Casters	24-09372-000

Cable & Power Management

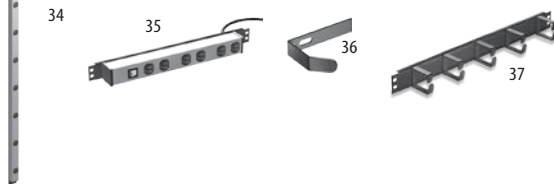

34	60" L Power Strip	12 Ports, 15 Amp, 6' Power Cord	24-09270-000
35	19" W Power Strip	6 Ports, 15 Amp, 19" Rackmountable Panel	24-09276-000
36	D - Wire Loops	Wire Loops - (Set of 10) - Mount to Rails	24-09250-000
37	Wire Loop Panel	19"W Horizontal Metal Wire Loop Panel (1 U)	24-09260-000

Hood Cover, Grommets, Lifting Lugs

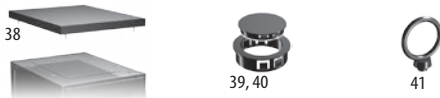

38	Hood Cover	24" Wide x 30" Deep	24-09520-030
39	Small Grommet	1.5" Dia. for cable protection - for sides	24-09610-000
40	Large Grommet	2.5" Dia. for cable protection - for top	24-09614-000
41	Lifting Lugs	Set of 4 - Required for lifting enclosure	24-09350-000

Fill-in Panels

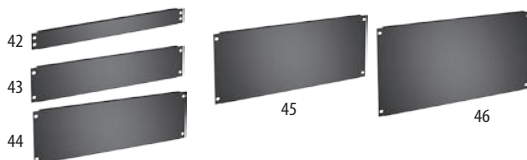

42	1 U Panel	1.75" High	24-09510-100
43	2 U Panel	3.50" High	24-09510-200
44	3 U Panel	5.25" High	24-09510-300
45	4 U Panel	7.00" High	24-09510-400
46	5 U Panel	8.75" High	24-09510-500

Lighting, Baying Kit, Mini- Keyboard



47	Internal Lighting	In-Cabinet Lighting, Rackmountable	24-09280-000
48	Baying Kit	4-Corner Assembly Kit	24-09300-000
49	Mini Keyboard	84 Keys, 13" Wide Keyboard, Black	24-09087-000
50	Mini Keyboard	84 Keys, 13" Wide Keyboard, Putty	24-09087-002

HEIGHT **26 U** WIDTH **24"** DEPTH **36"**

MARS Enclosure Cabinet

95-MARS0-000



Internal Equipment	Width: 19"	
Mounting Dimensions	Depth: Up to 34" Deep Equipment Height: 26 U (45.5")	
External Dimensions	50.50" High* x 24" Wide x 36" Deep	
Static Weight Capacity	Up to 1,400 lbs. with Industrial Casters	
Construction	Base & Top: Enhanced in all 4 corners by 11- Gauge gussets Upright Support: A 4 bend 16-Gauge design for strong vertical support Side Panels: Removable and Lockable from within the Enclosure Standard Color: Black. Quality Powder Coat Finish - Environmentally Friendly	
Baying	Connect 2 or more Enclosures and eliminate the need for Side Panels	
*Overall Height	Plain Height	50.50"
	With Gliders	51.25"
	With 2.75" Industrial Casters	53.25"
	With 4" Institutional Casters	55.50"

OPTIONS:

Frame, Mounting Rails, Screws & Cage Nuts

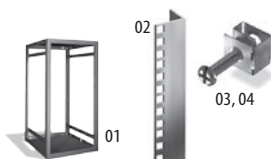

#	ITEM	DESCRIPTION	PART No.
01	Basic Standard Frame	24" Wide x 36" Deep	24-02602-360
02	Mounting Rails	Square Cage knock-outs (1 ea.)	24-02612-000
03	Mounting Screws	M6 x 16mm - Screws and-Cage Nuts, Bag of 25	55-01160-000
04	Mounting Screws	M6 x 16mm - Screws and-Cage Nuts, Bag of 50	55-01162-000

Side Panel, Front & Rear Doors



05	Side Panel	36" Deep, Bottom Louvered - ea.	24-02620-360
06	Front Door	Tempered Glass with Key-Lock	24-02630-003
07	Front Door	Fully Perforated with Key-Lock	24-02632-000
08	Rear Door	Tempered Glass with Key-Lock	24-02652-000
09	Rear Door	Fully Perforated with Key-Lock	24-02654-000
10	Rear Door	Solid, up to 3 Fans, with Key-Lock	24-02656-000

Fixed Shelves



All shelves require screws and cage-nuts for mounting in enclosure.

11	Fixed Shelf	24" Deep, Louvered, 350 lbs.	24-09052-000
12	Fixed Shelf	27" Deep, Louvered, 350 lbs.	24-09054-000
13	Cantilever Shelf	19" Wide, 12" Deep	14-00710-000
14	Cantilever Shelf	19" Wide, 15" Deep	14-00712-000

Slide-Out Shelves

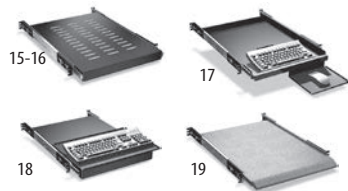

15	Slide-Out Shelf	24" Deep, Louvered, 100 lbs.	24-09062-100
16	Slide-Out Shelf	27" Deep, Louvered, 135 lbs.	24-09062-180
17	Slide-Out Shelf	For Mini Keyboard (13"Wide) & Mouse Pad	24-09080-000
18	Slide-Out Shelf	Swivel-out Full KB with Rear Mouse Area	24-09082-000
19	Slide-Out Shelf	Slide-Out Writing Desktop, 24" Deep	24-09084-000

Air Filter



20	Air Filter	For 36" Deep - Sold in single units.	24-09424-000
21	Cooling Fan	Quiet, 75 CFM (Use up to 3 in Rear Door)	24-09200-001

Specifications are subject to change without notice. Consult with a Hergo Account Executive today.

© Hergo Ergonomic Support Systems, Inc.

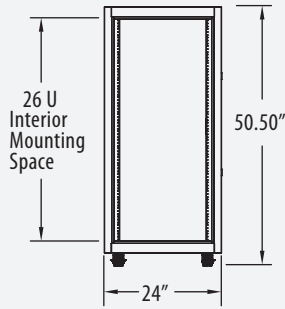
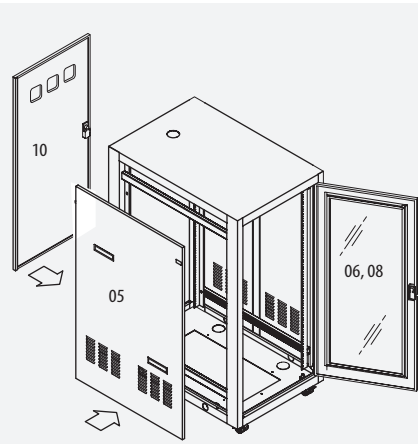

Front Elevation

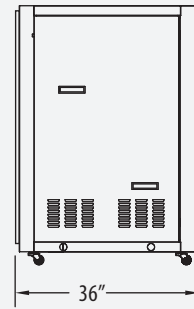

Side Elevation

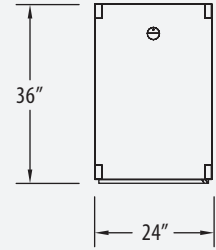

Floor Plan

OPTIONS:

Gliders, Casters, Stabilizers



#	ITEM	DESCRIPTION	PART No.
22	Glider	Heavy Duty Glider	28-00110-000
23	Caster	Dual Width, Heavy Duty, 2.75" High	28-00010-000
24	Caster	Dual Width, Heavy Duty, 2.75" High, Lockable	28-00012-000
25	Stabilizers	Enclosure Tilt Stabilizers (2 ea.) for unit with Gliders	24-09370-000
26	Stabilizers	Enclosure Tilt Stabilizers (2 ea.) for unit with Casters	24-09372-000

Cable & Power Management



27	48" L Power Strip	10 Ports, 15Amp, 6' Power Cord	24-09270-010
28	19" W Power Strip	6 Ports, 15Amp, 19" Rackmountable Panel	24-09276-000
29	D - Wire Loops	Wire Loops - (Set of 10) Mount to Rails	24-09250-000
30	Wire Loop Panel	19"W Horizontal Metal Wire Loop Panel (1 U)	24-09260-000

Grommets, Lifting Lugs



31	Small Grommet	1.5" Dia. for cable protection - for sides	24-09610-000
32	Large Grommet	2.5" Dia. for cable protection- for top	24-09614-000
33	Lifting Lugs	Set of 4 - Required for lifting enclosure	24-09350-000

Fill-in Panels

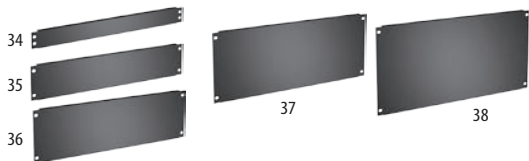

34	1 U Panel	1.75" High	24-09510-100
35	2 U Panel	3.50" High	24-09510-200
36	3 U Panel	5.25" High	24-09510-300
37	4 U Panel	7.00" High	24-09510-400
38	5 U Panel	8.75" High	24-09510-500

Lighting, Baying Kit, Mini- Keyboard



39	Internal Lighting	In-Cabinet Lighting, Rackmountable	24-09280-000
40	Baying Kit	4-Corner Assembly Kit	24-09300-000
41	Mini Keyboard	84 Keys, 13" Wide Keyboard, Black	24-09087-000
42	Mini Keyboard	84 Keys, 13" Wide Keyboard, Putty	24-09087-002

HEIGHT **26 U** WIDTH **24"** DEPTH **30"**

MARS 30 Enclosure Cabinet

95-MARS0-030



Internal Equipment	Width: 19"	
Mounting Dimensions	Depth: Up to 28" Deep Equipment Height: 26 U (45.5")	
External Dimensions	50.50" High* x 24" Wide x 30" Deep	
Static Weight Capacity	Up to 1,400 lbs. with Industrial Casters	
Construction	Base & Top: Enhanced in all 4 corners by 11- Gauge gussets Upright Support: A 4 bend 16-Gauge design for strong vertical support Side Panels: Removable and Lockable from within the Enclosure Standard Color: Black. Quality Powder Coat Finish - Environmentally Friendly	
Baying	Connect 2 or more Enclosures and eliminate the need for Side Panels	
*Overall Height	Plain Height	50.50"
	With Gliders	51.25"
	With 2.75" Industrial Casters	53.25"
	With 4" Institutional Casters	55.50"

OPTIONS:

Frame, Mounting Rails, Screws & Cage Nuts

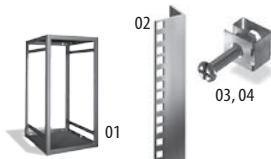

#	ITEM	DESCRIPTION	PART No.
01	Basic Standard Frame	24" Wide x 30" Deep	24-02602-300
02	Mounting Rails	Square Cage knock-outs (1 ea.)	24-02612-000
03	Mounting Screws	M6 x 16mm - Screws and-Cage Nuts, Bag of 25	55-01160-000
04	Mounting Screws	M6 x 16mm - Screws and-Cage Nuts, Bag of 50	55-01162-000

Side Panel, Front & Rear Doors



05	Side Panel	30" Deep, Bottom Louvered - ea.	24-02620-300
06	Front Door	Tempered Glass with Key-Lock	24-02630-003
07	Front Door	Fully Perforated with Key-Lock	24-02632-000
08	Rear Door	Tempered Glass with Key-Lock	24-02652-000
09	Rear Door	Fully Perforated with Key-Lock	24-02654-000
10	Rear Door	Solid, up to 3 Fans, with Key-Lock	24-02656-000

Fixed Shelves



All shelves require screws and cage-nuts for mounting in enclosure.

11	Fixed Shelf	24" Deep, Louvered, 350 lbs.	24-09052-000
12	Fixed Shelf	27" Deep, Louvered, 350 lbs.	24-09054-000
13	Cantilever Shelf	19" Wide, 12" Deep	14-00710-000
14	Cantilever Shelf	19" Wide, 15" Deep	14-00712-000

Slide-Out Shelves

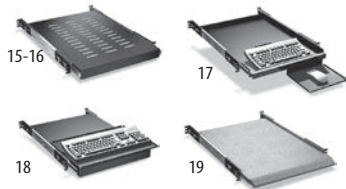

15	Slide-Out Shelf	24" Deep, Louvered, 100 lbs.	24-09062-100
16	Slide-Out Shelf	27" Deep, Louvered, 135 lbs.	24-09062-180
17	Slide-Out Shelf	For Mini Keyboard (13"Wide) & Mouse Pad	24-09080-000
18	Slide-Out Shelf	Swivel-out Full KB with Rear Mouse Area	24-09082-000
19	Slide-Out Shelf	Slide-Out Writing Desktop, 24" Deep	24-09084-000

Air Filter



20	Air Filter	For 30" Deep - Sold in single units.	24-09414-000
21	Cooling Fan	Quiet, 75 CFM (Use up to 3 in Rear Door)	24-09200-001

Specifications are subject to change without notice. Consult with a Hergo Account Executive today.

© Hergo Ergonomic Support Systems, Inc.

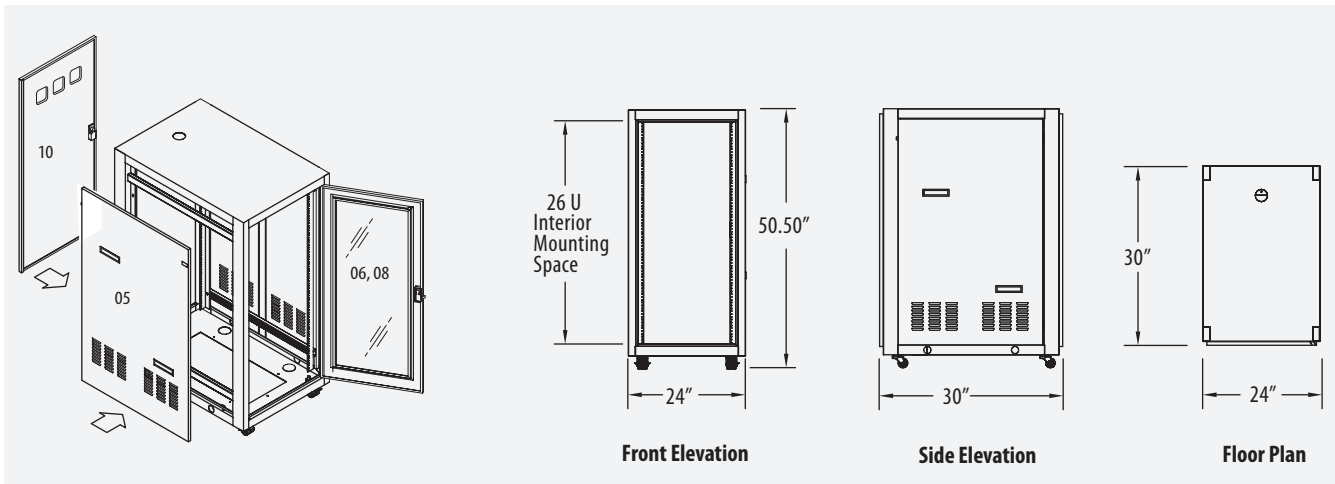

OPTIONS:

Gliders, Casters, Stabilizers



#	ITEM	DESCRIPTION	PART No.
22	Glider	Heavy Duty Glider	28-00110-000
23	Caster	Dual Width, Heavy Duty, 2.75" High	28-00010-000
24	Caster	Dual Width, Heavy Duty, 2.75" High, Lockable	28-00012-000
25	Stabilizers	Enclosure Tilt Stabilizers (2 ea.) for unit with Gliders	24-09370-000
26	Stabilizers	Enclosure Tilt Stabilizers (2 ea.) for unit with Casters	24-09372-000

Cable & Power Management



27	48" L Power Strip	10 Ports, 15Amp, 6' Power Cord	24-09270-010
28	19" W Power Strip	6 Ports, 15Amp, 19" Rackmountable Panel	24-09276-000
29	D - Wire Loops	Wire Loops - (Set of 10) Mount to Rails	24-09250-000
30	Wire Loop Panel	19"W Horizontal Metal Wire Loop Panel (1 U)	24-09260-000

Grommets, Lifting Lugs



31	Small Grommet	1.5" Dia. for cable protection - for sides	24-09610-000
32	Large Grommet	2.5" Dia. for cable protection- for top	24-09614-000
33	Lifting Lugs	Set of 4 - Required for lifting enclosure	24-09350-000

Fill-in Panels

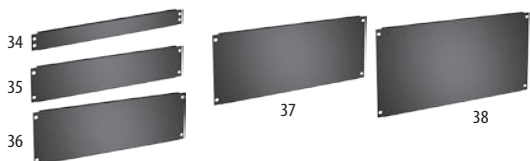

34	1 U Panel	1.75" High	24-09510-100
35	2 U Panel	3.50" High	24-09510-200
36	3 U Panel	5.25" High	24-09510-300
37	4 U Panel	7.00" High	24-09510-400
38	5 U Panel	8.75" High	24-09510-500

Lighting, Baying Kit, Mini-Keyboard

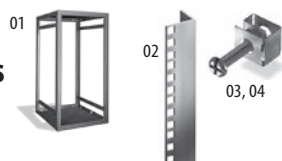
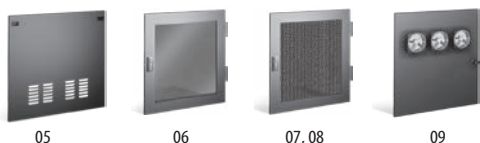

39	Internal Lighting	In-Cabinet Lighting, Rackmountable	24-09280-000
40	Baying Kit	4-Corner Assembly Kit	24-09300-000
41	Mini Keyboard	84 Keys, 13" Wide Keyboard, Black	24-09087-000
42	Mini Keyboard	84 Keys, 13" Wide Keyboard, Putty	24-09087-002

HEIGHT **12 U** WIDTH **24"** DEPTH **36"****95-MERCU-036****OPTIONS:****Frame,
Mounting Rails,
Screws & Cage Nuts****Side Panel, Front & Rear Doors****Fixed Shelves**

All shelves require screws and cage-nuts for mounting in enclosure.

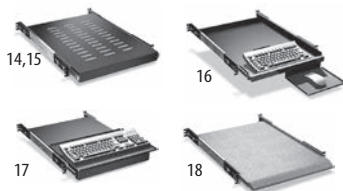
Slide-Out Shelves**Cooling Fans, Air Filters****MERCURY Under-Desk Enclosure****Internal Equipment** Width: 19"**Mounting Dimensions** Depth: Up to 34" Deep Equipment
Height: 12 U (21")**External Dimensions** 26.25" High* x 24" Wide x 36" Deep**Static Weight Capacity** Up to 1000 lbs. with Industrial Casters

Construction

Base & Top: Enhanced in all 4 Corners by 11-Gauge Gussets

Upright Support: A 4 bend 16-Gauge design for strong vertical support

Side Panels: Removable and Lockable from within the Enclosure

Standard Color: Black. Quality Powder Coat Finish - Environmentally Friendly

***Overall Height**

Plain Height	26.25"
With Gliders	27.00"
With 2.75" Industrial Casters	29.25"
With 4" Institutional Casters	30.25"

#	ITEM	DESCRIPTION	PART No.
01	Basic Standard Frame	24" Wide x 36" Deep	24-01202-036
02	Mounting Rails	Square Cage knock-outs (1 ea.)	24-01214-000
03	Mounting Screws	M6 x 16mm - Screws and-Cage Nuts, Bag of 25	55-01160-000
04	Mounting Screws	M6 x 16mm - Screws and-Cage Nuts, Bag of 50	55-01162-000
05	Side Panel	36" Deep, Bottom Louvered - ea.	24-01220-036
06	Front Door	Glass with Key-Lock	24-01230-000
07	Front Door	Fully Perforated with Key-Lock	24-01250-010
08	Rear Door	Fully Perforated with Key-Lock	24-01250-011
09	Rear Door	Solid, Up to 3 Fans	24-01250-000
10	Fixed Shelf	24" Deep, Louvered, 350 lbs.	24-09052-000
11	Fixed Shelf	27" Deep, Louvered, 350 lbs.	24-09054-000
12	Cantilever Shelf	19" Wide, 12" Deep	14-00710-000
13	Cantilever Shelf	19" Wide, 15" Deep	14-00712-000
14	Slide-Out Shelf	24" Deep, Louvered, 100 lbs.	24-09062-100
15	Slide-Out Shelf	27" Deep, Louvered, 135 lbs.	24-09062-180
16	Slide-Out Shelf	For Mini-Keyboard (13" Wide) & Mouse Pad	24-09080-000
17	Slide-Out Shelf	Swivel-out Full KB with Rear Mouse Area	24-09082-000
18	Slide-Out Shelf	Slide-Out Writing Desktop, 24" Deep	24-09084-000
19	Air Filter	For 36" Deep - Sold in single units.	24-09424-000
20	Cooling Fan	Quiet, 75 CFM (Use up to 3 in Rear Door)	24-09200-001

Specifications are subject to change without notice. Consult with a Hergo Account Executive today.

© Hergo Ergonomic Support Systems, Inc.

hergo TECHNICAL WORKSPACE SOLUTIONS 56-01 55th Avenue, Maspeth, New York 11378 | Tel: 888-222-7270 | Fax: 888-410-0671 | www.hergo.com

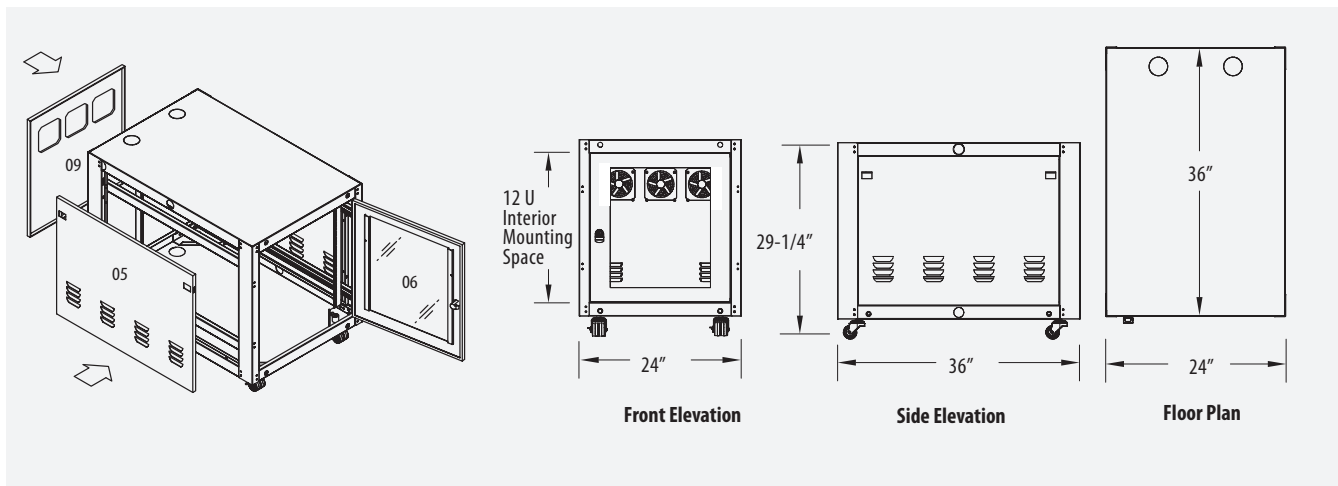

OPTIONS:

Gliders, Casters, Stabilizers



#	ITEM	DESCRIPTION	PART No.
21	Glider	Heavy Duty Glider	28-00110-000
22	Caster	Dual Width, Heavy Duty, 2.75" High	28-00010-000
23	Caster	Dual Width, Heavy Duty, 2.75" High, Lockable	28-00012-000
24	Stabilizers	Enclosure Tilt Stabilizers (2 ea) for unit with Gliders	24-09370-000
25	Stabilizers	Enclosure Tilt Stabilizers (2 ea) for unit with Casters	24-09372-000

Cable & Power Management



26	19" W Power Strip	6 Ports, 19" Rackmountable Panel	24-09276-000
27	D - Wire Loops	Wire Loops - (Set of 10) Mount to Rails	24-09250-000
28	Wire Loop Panel	19" Wide Horizontal Metal Wire Loop Panel (1U)	24-09260-000

Grommets, Lifting Lugs



29	Small Grommet	1.5" Dia. for cable protection - for sides	24-09610-000
30	Large Grommet	2.5" Dia. for cable protection - for top	24-09614-000
31	Lifting Lugs	Set of 4 - Required for lifting enclosure	24-09350-000

Fill-in Panels

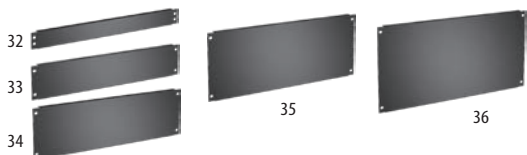

32	1 U Panel	1.75" High	24-09510-100
33	2 U Panel	3.50" High	24-09510-200
34	3 U Panel	5.25" High	24-09510-300
35	4 U Panel	7.00" High	24-09510-400
36	5 U Panel	8.75" High	24-09510-500

Lighting, Mini-Keyboard

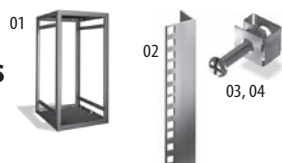
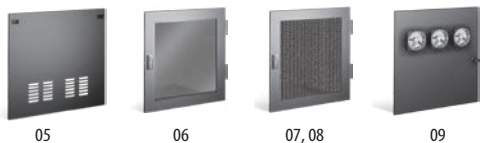

37	Internal Lighting	In-Cabinet Lighting, Rackmountable	24-09280-000
38	Mini Keyboard	84 Keys, 13" Wide Keyboard, Black	24-09087-000
39	Mini Keyboard	84 Keys, 13" Wide Keyboard, Putty	24-09087-002

HEIGHT **12 U** WIDTH **24"** DEPTH **30"****95-DSKMT-030****OPTIONS:****Frame,
Mounting Rails,
Screws & Cage Nuts****Side Panel, Front & Rear Doors****Fixed Shelves**

All shelves require screws and cage-nuts for mounting in enclosure.

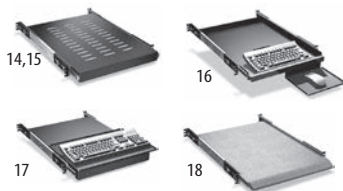
Slide-Out Shelves**Cooling Fans, Air Filters****DESKMATE 30 Enclosure****Internal Equipment** Width: 19"**Mounting Dimensions** Depth: Up to 28" Deep Equipment
Height: 12 U (21")**External Dimensions** 26.25" High* x 24" Wide x 30" Deep**Static Weight Capacity** Up to 1000 lbs. with Industrial Casters

Construction

Base & Top: Enhanced in all 4 Corners by 11-Gauge Gussets

Upright Support: A 4 bend 16-Gauge design for strong vertical support

Side Panels: Removable and Lockable from within the Enclosure

Standard Color: Black. Quality Powder Coat Finish - Environmentally Friendly

***Overall Height**

Plain Height	26.25"
With Gliders	27.00"
With 2.75" Industrial Casters	29.25"
With 4" Institutional Casters	30.25"

#	ITEM	DESCRIPTION	PART No.
01	Basic Standard Frame	24" Wide x 30" Deep	24-01202-030
02	Mounting Rails	Square Cage knock-outs (1 ea.)	24-01214-000
03	Mounting Screws	M6 x 16mm - Screws and-Cage Nuts, Bag of 25	55-01160-000
04	Mounting Screws	M6 x 16mm - Screws and-Cage Nuts, Bag of 50	55-01162-000
05	Side Panel	30" Deep, Bottom Louvered - ea.	24-01220-030
06	Front Door	Glass with Key-Lock	24-01230-000
07	Front Door	Fully Perforated with Key-Lock	24-01250-010
08	Rear Door	Fully Perforated with Key-Lock	24-01250-011
09	Rear Door	Solid, Up to 3 Fans	24-01250-000
10	Fixed Shelf	24" Deep, Louvered, 350 lbs.	24-09052-000
11	Fixed Shelf	27" Deep, Louvered, 350 lbs.	24-09054-000
12	Cantilever Shelf	19" Wide, 12" Deep	14-00710-000
13	Cantilever Shelf	19" Wide, 15" Deep	14-00712-000
14	Slide-Out Shelf	24" Deep, Louvered, 100 lbs.	24-09062-100
15	Slide-Out Shelf	27" Deep, Louvered, 135 lbs.	24-09062-180
16	Slide-Out Shelf	For Mini-Keyboard (13" Wide) & Mouse Pad	24-09080-000
17	Slide-Out Shelf	Swivel-out Full KB with Rear Mouse Area	24-09082-000
18	Slide-Out Shelf	Slide-Out Writing Desktop, 24" Deep	24-09084-000
19	Air Filter	For 30" Deep - Sold in single units.	24-09414-000
20	Cooling Fan	Quiet, 75 CFM (Use up to 3 in Rear Door)	24-09200-001

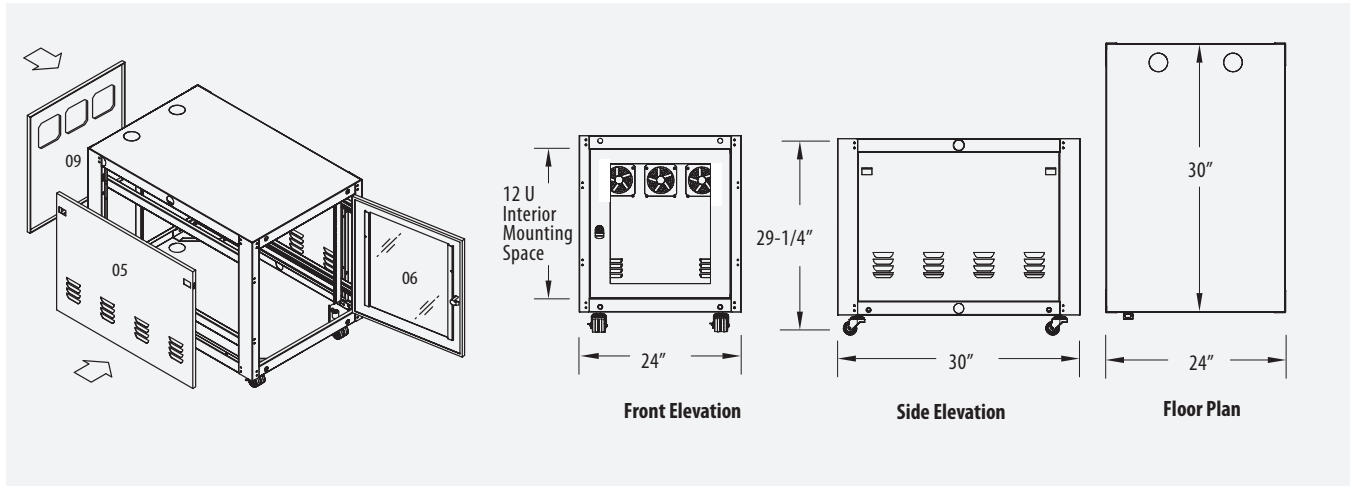

OPTIONS:

Gliders, Casters, Stabilizers

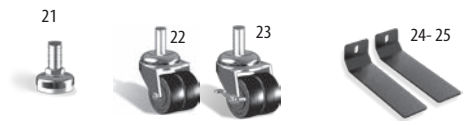

#	ITEM	DESCRIPTION	PART No.
21	Glider	Heavy Duty Glider	28-00110-000
22	Caster	Dual Width, Heavy Duty, 2.75" High	28-00010-000
23	Caster	Dual Width, Heavy Duty, 2.75" High, Lockable	28-00012-000
24	Stabilizers	Enclosure Tilt Stabilizers (2 ea) for unit with Gliders	24-09370-000
25	Stabilizers	Enclosure Tilt Stabilizers (2 ea) for unit with Casters	24-09372-000

Cable & Power Management



26	19" W Power Strip	6 Ports, 19" Rackmountable Panel	24-09276-000
27	D - Wire Loops	Wire Loops - (Set of 10) Mount to Rails	24-09250-000
28	Wire Loop Panel	19" Wide Horizontal Metal Wire Loop Panel (1U)	24-09260-000

Grommets, Lifting Lugs



29	Small Grommet	1.5" Dia. for cable protection - for sides	24-09610-000
30	Large Grommet	2.5" Dia. for cable protection - for top	24-09614-000
31	Lifting Lugs	Set of 4 - Required for lifting enclosure	24-09350-000

Fill-in Panels

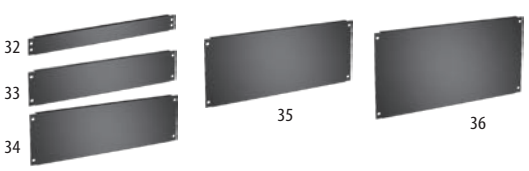

32	1 U Panel	1.75" High	24-09510-100
33	2 U Panel	3.50" High	24-09510-200
34	3 U Panel	5.25" High	24-09510-300
35	4 U Panel	7.00" High	24-09510-400
36	5 U Panel	8.75" High	24-09510-500

Lighting, Mini-Keyboard



37	Internal Lighting	In-Cabinet Lighting, Rackmountable	24-09280-000
38	Mini Keyboard	84 Keys, 13" Wide Keyboard, Black	24-09087-000
39	Mini Keyboard	84 Keys, 13" Wide Keyboard, Putty	24-09087-002

HEIGHT 12 U | **WIDTH 24"** | **DEPTH 36"**

ApxServer-12 Under-Desk Enclosure

95-APXSE-012



Internal Equipment	Width: 19"
Mounting Dimensions	Depth: Up to 34" Deep Equipment Height: 12 U (21")
External Dimensions	26.25" High* x 24" Wide x 36" Deep
Static Weight Capacity	Up to 1000 lbs. with Industrial Casters
Standard Color	Black
Includes:	12 U Basic Frame 2 Side Panels- 36" Deep Rear Locking Door with 3 Fans, 75 CFM Front Locking Door Noise Reduction Foam Class A - Class 1 Fire Rated - UL 94V0 4 Mounting Rails - Square Cage Knockout 2 Lockable and 2 Non-Lockable Casters

* Overall Enclosure Height:
 Plain Height 26.25"
 With Gliders 27.00"
 With Industrial Casters 29.25"
 With 4" Institutional Casters 30.25"

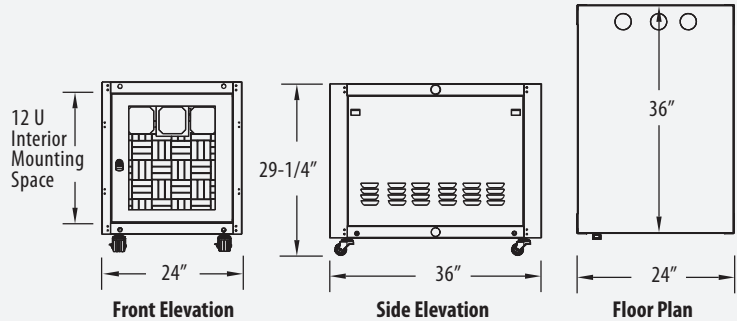
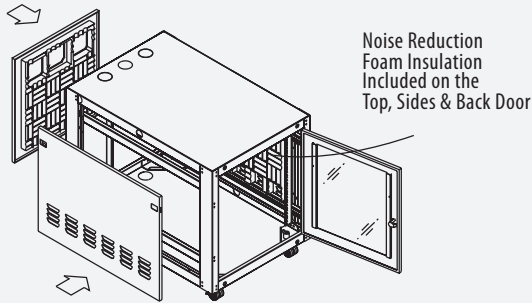

HEIGHT 26 U | **WIDTH 24"** | **DEPTH 36"**

ApxServer-26 Mid-Size Enclosure

95-APXSE-026



Internal Equipment	Width: 19"
Mounting Dimensions	Depth: Up to 34" Deep Equipment Height: 26 U (45.5")
External Dimensions	50.50" High* x 24" Wide x 36" Deep
Static Weight Capacity	Up to 1,000 lbs. with Industrial Casters
Standard Color	Black
Includes:	26 U Basic Frame 2 Side Panels- 36" Deep Rear Locking Door with 3 Fans, 75 CFM Front Locking Door Noise Reduction Foam Class A - Class 1 Fire Rated - UL 94V0 4 Mounting Rails - Square Cage Knockout 2 Lockable and 2 Non-Lockable Casters

* Overall Enclosure Height:
 Plain Height 50.50"
 With Gliders 51.25"
 With 2.75" Industrial Casters 53.25"
 With 4" Institutional Casters 55.50"

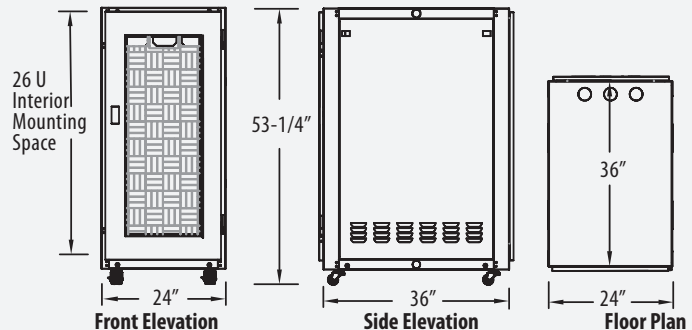
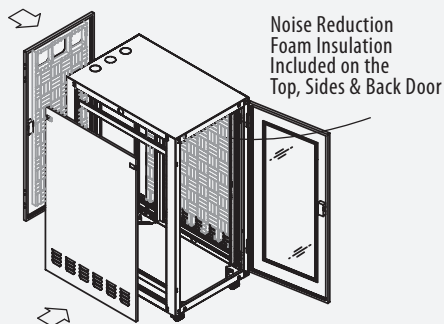

Specifications are subject to change without notice. Consult with a Hergo Account Executive today.

© Hergo Ergonomic Support Systems, Inc.

HEIGHT **42U** WIDTH **23"** DEPTH **38"**

ApXServer-42 Full-Size Enclosure

95-APXSE-042

Internal Equipment	Width: 19"
Mounting Dimensions	Depth: Up to 34" Deep Equipment Height: 42 U (73.5")
External Dimensions	77.5" High* x 23" Wide x 38" Deep
Static Weight Capacity	Up to 1400 lbs. with Industrial Casters
Standard Color	Black
Includes:	<ul style="list-style-type: none"> 42 U Basic Frame 2 Side Panels - 38" Deep Rear Locking Door Front Locking Door Top Fan Assembly with 4 Fans, 300 CFM Noise Reduction Foam Class A - Class 1 Fire Rated - UL 94V0 4 Mounting Rails - Square Cage Knockout 2 Lockable and 2 Non-Lockable Casters 8 Cable Management Loops Brush Insert Cable Thruway

* Overall Enclosure Height:	Plain Height 77.5"
	With Gliders 78.5"
	With Industrial Casters 80.5"
	With 4" Institutional Casters 82.5"

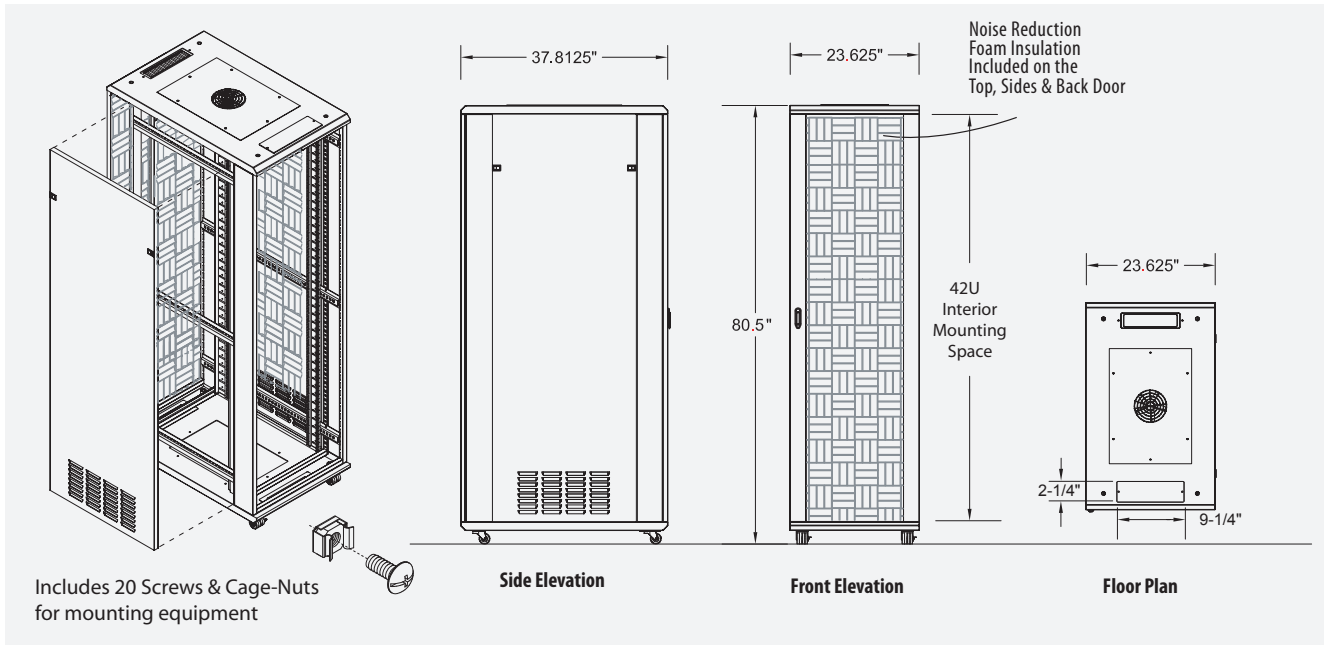
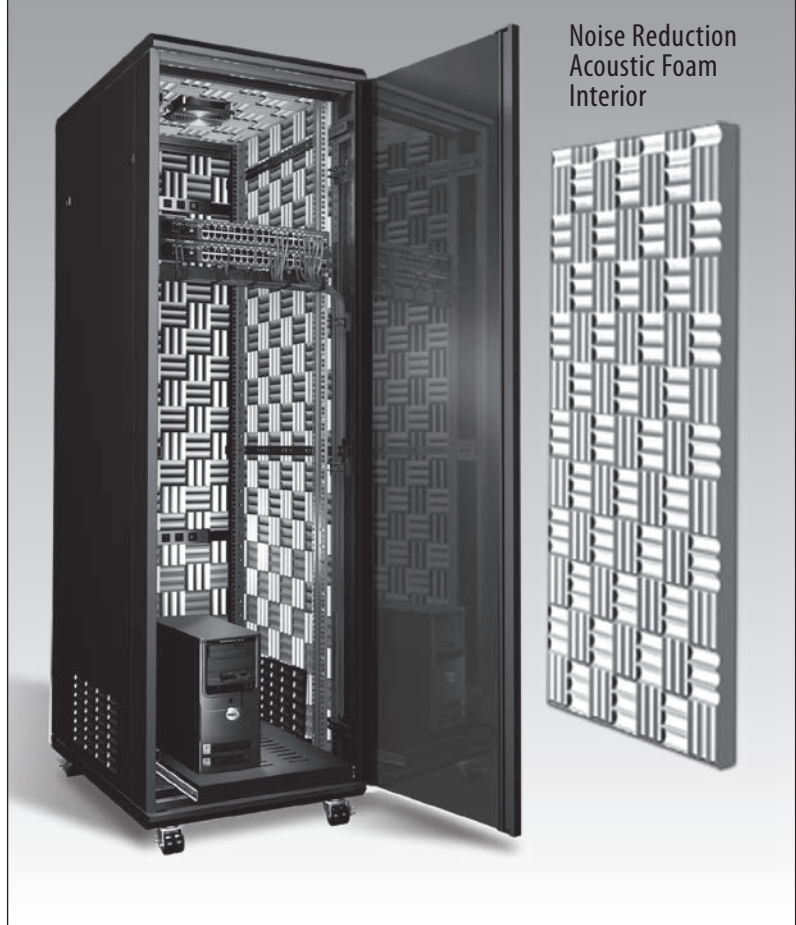

Specifications are subject to change without notice. Consult with a Hergo Account Executive today.

© Hergo Ergonomic Support Systems, Inc.

Hergo Ergonomic Support Systems, Inc., designs, manufactures and markets an extensive line of functionally engineered modular technical office furniture.



Hergo's products include:

- Open Computer Racking Systems
- Computer Enclosures and Cabinets
- Relay Racks for Computers and Communications Equipment
- Personal Workstations & Computer Desks
- Training/Studio Desks
- Flat Panel Monitor (LCD) Arms
- Mobile Hospital Carts
- PACS Workstations

We provide customers with free space design consultation, including CAD drawings and simulated environment renderings, to help maximize user space and productivity.

Save time and money. Visit our dynamic and resourceful website: www.hergo.com.

We are located at: 56-01 55th Avenue
Maspeth, New York 11378.

Further assistance is just a phone call away.



TECHNICAL WORKSPACE SOLUTIONS
Approved supplier to all branches of the U.S. Government



1-888-222-7270
www.hergo.com

PROUDLY MADE IN NEW YORK CITY

Actual structure design and depictions may vary. Specifications and prices are subject to change without prior notice. | © Hergo® Ergonomic Support Systems, Inc.