

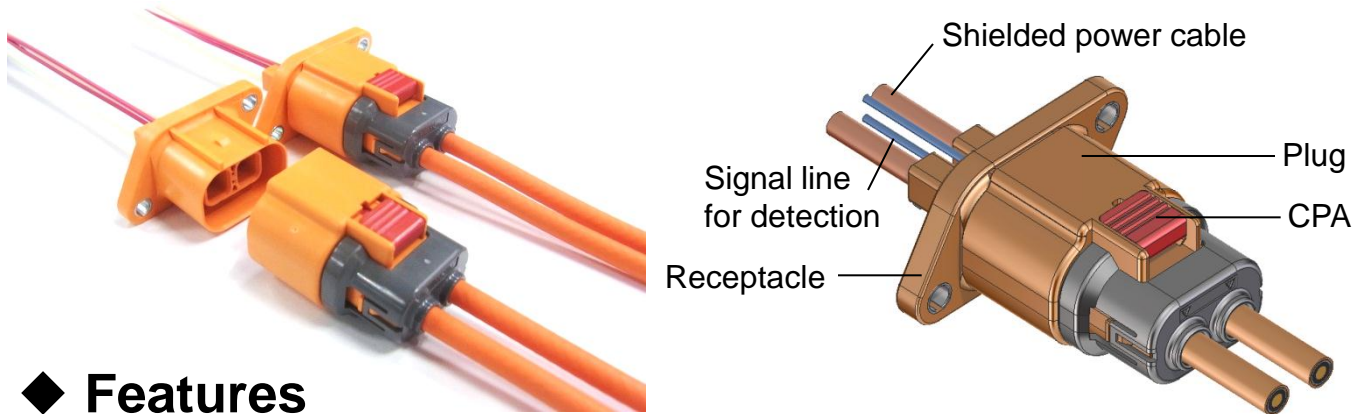

GT28WS Series

MKT-E-14038F

Compact and Waterproof Panel Mount In-line Connector with Electrical Shields



◆ Features

1. Compact structure supporting up to 30 Amps.
2. Safety structure with built-in mating detection mechanism.
3. CPA (Connector Position Assurance) unit to ensure secure mating.
4. IPX9K* compliant waterproof structure.
5. Enhanced EMI prevention with metal shield.
6. Easy cable assembly.
7. Satisfies stringent test conditions for various in-vehicle equipment.
8. RoHS and ELV compliant.

* No water intrusion in four directions for 30 seconds by water jet (water pressure 8 Mpa to 10 Mpa, water temperature 80±5 °C) emission from 100 mm to 150 mm distance.

◆ Dimensions (Power 2 pos. + Signal 2 pos.)

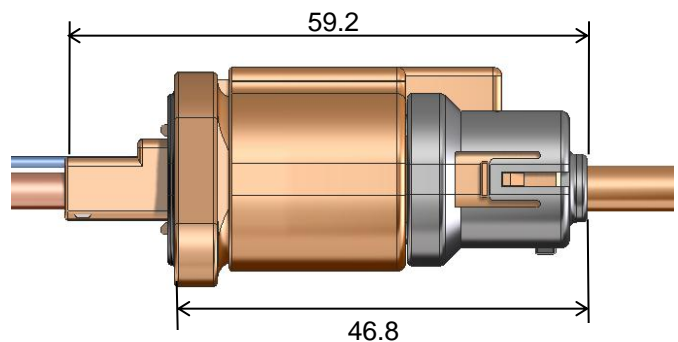
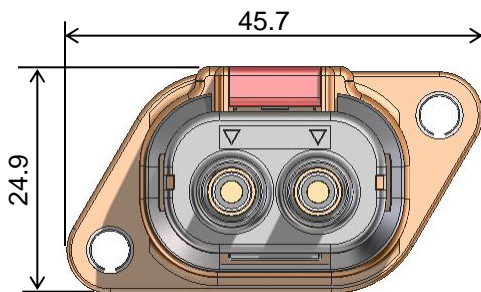

◆ Specifications

Rated Current	30 Amps	Operating Temperature Range	- 40 °C to + 125 °C	
Rated Voltage	AC/DC 600V	Insulation Resistance	100 MΩ or above [DC 1000V]	
Contact Resistance	Power	3 mΩ or below [DC 30A]	Withstanding Voltage	AC 2000 V for 1 minute
	Signal	10 mΩ or below [DC 30A]	Durability	10 cycles
	Ground	50 mΩ or below [DC 30A]		

Specifications herein are subject to change without notice. Contact Hirose for latest specifications, drawings, or availabilities.