

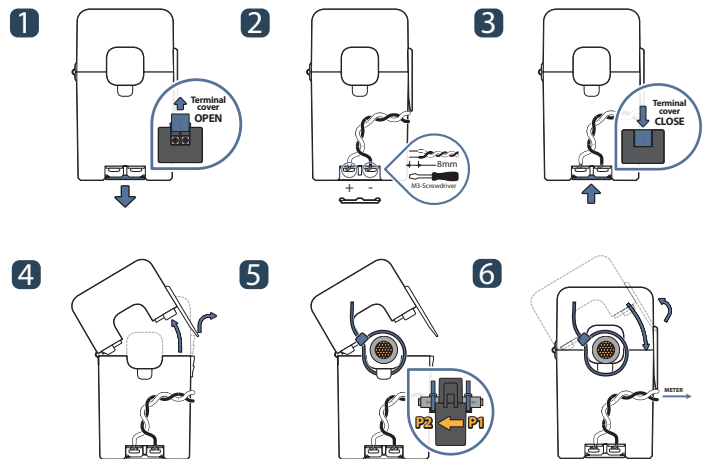

PRECISION SPLIT-CORE CURRENT TRANSDUCER JCXXX-XXX-V series



HOW TO USE



The Split-core Current Transducer, V Series, is designed for energy management, with a convenient connection to electronic submeter. It may also be applied for current measurement in a system of distributed power line carriers (PLCs) or remote controls such as SCADA software for automation and supervision. Other applications include security and condition monitoring, load monitoring, in protection systems, and for predictive maintenance of conveyers, pumps or HVAC motors.

APPLICATIONS

- HVAC & Pumps
- Refrigeration
- Small Industrial Motors
- Fans
- Lighting

FEATURES

- Nylon-spring, output-terminal, secure locking hinge, one-touch structure makes easy to install to the existent equipments such as a power distribution boards.
- Isolated plastic case recognized according to UL94-V0
- UL / EN 61010 -1 certified

BENEFITS

- Small-size, light-weight
- Simple Installation
- Over-Voltage protection circuit is installed.

NOTICE

- If you impact the core contact surface, internal core material could be damaged.(Ø10, Ø16 type)
- Core contact surface is waterproofed, however if it gets rusty, you could reuse after removing rusts with spraying WD-40 or CRC5-56 on the rusted side(Ø24, Ø36 type).
- Do not use any other chemicals except WD-40 or CRC5-56 on housing or any other parts.
- Please use only the original output screws. Not recommended to replace it with anything else.
- Customizing output lead wire

SPECIFICATION

(F=50/60Hz)

Model	JCXXFXXX-V						JCXXSXXX-V	
	Ø10		Ø16		Ø24		Ø36	
Current Range(Arms)	5	10	20	25	50	100	250	500
Max. Allowable Current	100%(Continuous), 150%(1min.)							
Output	0~5V DC (Average)/0~Rated Current, 7.5V DC Limiter built-in							
Accuracy / Linearity	±2% FS. Dynamic Range 1:100(50/60Hz Sinewave)							
Output Impedance	7 kΩ	8.5 kΩ	6.8 kΩ	6.8 kΩ	6.2 kΩ	5.8 kΩ	5.8 kΩ	5.8 kΩ
Sensor Supply Voltage	Self-Powered							
Response Time	300ms							
Output Ripple Voltage	Within 5% of Output Voltage							
Output Terminals	2 x M3-Screw, with Terminals cover							
Insulation Category	CAT III							
Operating Condition	-20°C~+50°C, ≤85%RH, No condensation, In-house & Any direction installable							
Storage Condition	-30°C~+90°C, ≤85%RH, No condensation							



PERFORMANCE / INTERNAL CIRCUIT DRAWINGS

JCV Average

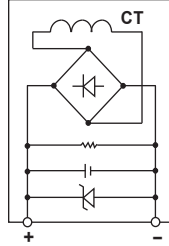
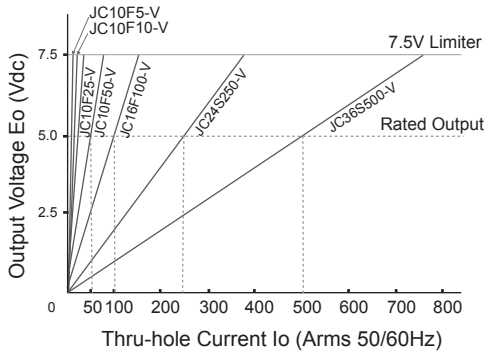

		JCØFXXX-V					JCØSXXX-V		
Std. Model	Ø	10					16	24	36
	XXX	5	10	20	25	50	100	250	500
Output Impedance(kΩ)		7	8.5	6.8	6.2	5.8			

APPLICATIONS / DIMENSION

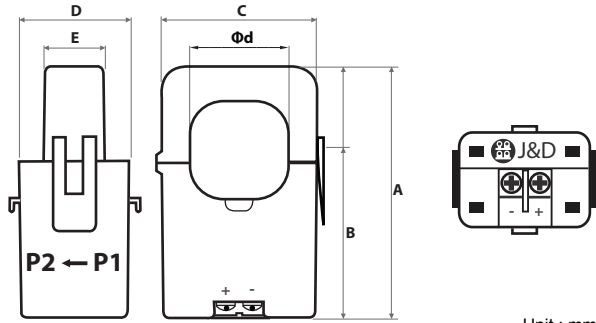
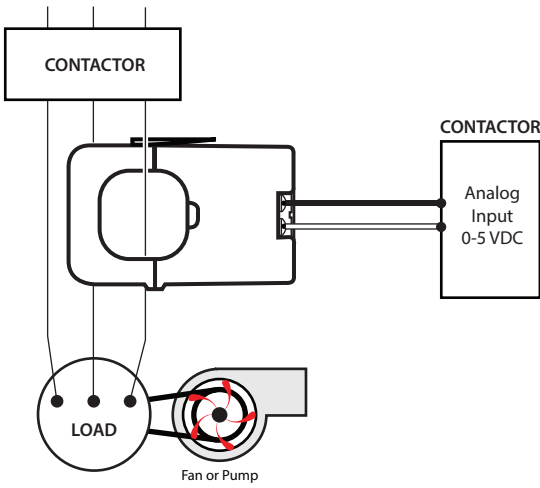

Model	A	B	C	D	E	Ød
JC10F	50	38	23	26	14.5	10
JC16F	55	41	29.5	31	19	16
JC24S	74.5	52	45	34	22	24
JC36S	91	62	57	40.5	22	36