

Wristband transponder „Standard“



Technologies:

125 kHz:

Hitag-1
Hitag-2
EM 4102
EM 4150

13,56 MHz:

Mifare
Legic
I-Code

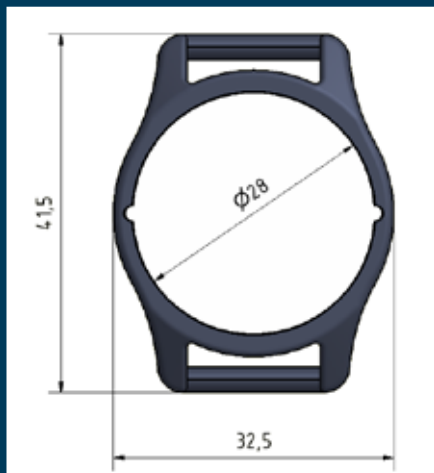

Colours casing and cover (similar):

black RAL9011	grey RAL7035
red RAL3000	yellow RAL1016
blue RAL5017	green RAL6024

Construction / application:

The casing of the wristwatch-style transponder is moulded from high quality ABS Novodur plastic, making it extremely resistant to breakage and shock.

With its ultrasonically welded cover, the casing is sealed watertight and tamperproof. This provides a high degree of security for the user, and also for the operator of contactless payment and access systems.

Since the casing is watertight to a depth of about 5 m, it is ideally suited for use in swimming pools, saunas and other leisure facilities. With its armband of Perlon mesh and clasp, combined with the attractive shape of the casing, the unit is very comfortable to wear.

Colours / combinations:

The standard colours for the casing are black, grey, dark blue and red (see colour table).

The cover of the casing is available in a variety of styles.

The standard colours for the cover are grey and black, with blue, red, yellow and green available as special colours, and other colours on requests.

The cover can also be inscribed and personalised in various ways, from laser inscription of a number to UV printing of a personalised 4-colour image or lamination.

The band is usually supplied in black, but other colours are available on request, as above.

The chip can also be programmed individually if required (R/W only).

hr electronic gmbh
Vogelherd 23
D-78176 Blumberg

Phone: +49 (0)7702-477 960

Fax: +49 (0)7702-477 989

Email: info@hrelectronic.com

Internet: www.hrelectronic.com

Wristband transponder „Exclusive“



Technologies:

125 kHz:

Hitag-1
Hitag-2
EM 4102
EM 4150

13,56 MHz:

Mifare
Legic
I-Code

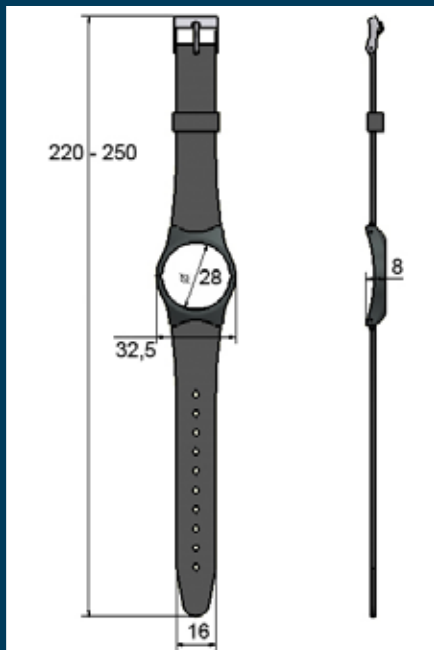

Colours casing and cover (similar):

black RAL9011	white RAL9016
red RAL3000	yellow RAL1016
blue RAL5017	green RAL6024

Construction / application:

The appeal of this exclusive wristband transponder lies in its linear, modern design and ease and comfort of wear. The casing is moulded from high quality ABS Novodur plastic, and thus extremely resistant to breakage and shock.

The ultrasonically welded cover makes the casing watertight tamperproof. This provides a high degree of security for the user, and also for the operator of contactless payment and access systems.

Because the fob casing is watertight to a depth of about 5m, it is ideal for use in swimming pools, saunas and other leisure facilities. With its attractive polyurethane armband, the unit is comfortable to wear.

Farben / Kombinationen: Colours / combinations:

The casing is supplied in black, red and dark blue (see colour table).

The standard colour for the cover is white, with blue, red, yellow and green available as special colours. Other colours are available on request.

The cover can also be inscribed and personalised in various ways, from laser inscription of a number to UV printing of a personalised 4-colour image or lamination.

The band is usually supplied in black, but other colours are available on request, as above.

The chip can also be programmed individually if required (R/W only).