



H&S Manufacturing Punch Press Tool List

List of Tooling

Diameters	Pg. 2
Rectangles	Pg. 3
Squares	Pg. 4
Rectangles w/radius Corners	Pg. 4
Squares w/radius corners	Pg. 5
Obrounds or oval slots	Pg. 5-6
Single D's	Pg. 6
Double D's	Pg. 6
Tapping Inserts for Punch Press	Pg. 6
Form Down Countersinks	Pg. 7
Form Up Countersinks	Pg. 8
Form Tooling	Pg. 9-20
Louvers	Pg. 21
Shear Buttons	Pg. 22-24
Lances	Pg. 25-29
Extrusions	Pg. 30-31
Card Guides	Pg. 32-34
Pedestal Dies	Pg. 35-36
Dimples	Pg. 37-45
Cluster Punches	Pg. 46
Tab Tools	Pg. 47
Inner Keyway	Pg. 48
Connector Punches	Pg. 49-51
Trapezoids	Pg. 52
Raduis Tooling	Pg. 53-61
Special Shapes	Pg. 62-79
Counter Bores	Pg. 80-83



H&S Manufacturing Co.

CONTRACT MANUFACTURING

Diameter Tool List	Diameter Tool List	Diameter Tool List	Diameter Tool List	Diameter Tool List	Diameter Tool List	Diameter Tool List
Size	Size	Size	Size	Size	Size	Size
0.032	0.137	0.228	0.397	0.671	1.156	2.272
0.038	0.138	0.234	0.406	0.687	1.187	2.283
0.043	0.140	0.238	0.413	0.703	1.200	2.360
0.046	0.142	0.242	0.416	0.718	1.218	2.375
0.053	0.144	0.246	0.421	0.722	1.234	2.385
0.058	0.147	0.250	0.426	0.734	1.250	2.450
0.063	0.149	0.252	0.437	0.750	1.250	2.500
0.067	0.150	0.257	0.445	0.755	1.281	2.660
0.070	0.152	0.261	0.453	0.760	1.285	2.890
0.073	0.154	0.265	0.458	0.770	1.296	3.000
0.076	0.156	0.266	0.460	0.765	1.350	3.125
0.078	0.159	0.272	0.468	0.781	1.362	3.375
0.078	0.161	0.277	0.471	0.796	1.375	3.452
0.080	0.162	0.278	0.473	0.812	1.390	3.500
0.081	0.163	0.281	0.480	0.828	1.398	4.000
0.086	0.166	0.290	0.484	0.843	1.437	4.094
0.089	0.168	0.296	0.490	0.849	1.472	4.500
0.093	0.169	0.302	0.500	0.855	1.500	
0.096	0.171	0.312	0.500	0.859	1.530	
0.098	0.173	0.316	0.502	0.875	1.560	
0.100	0.177	0.321	0.515	0.877	1.584	
0.101	0.180	0.320	0.520	0.885	1.612	
0.101	0.182	0.323	0.525	0.890	1.625	
0.102	0.185	0.328	0.531	0.906	1.653	
0.104	0.187	0.332	0.550	0.921	1.654	
0.106	0.189	0.342	0.562	0.937	1.657	
0.109	0.191	0.343	0.563	0.953	1.660	
0.111	0.193	0.344	0.573	0.968	1.675	
0.113	0.196	0.347	0.593	0.984	1.693	
0.116	0.199	0.348	0.600	1.000	1.730	
0.120	0.201	0.354	0.609	1.011	1.750	
0.121	0.203	0.359	0.619	1.012	1.788	
0.124	0.205	0.364	0.625	1.020	1.818	
0.125	0.209	0.368	0.625	1.032	1.875	
0.128	0.213	0.375	0.627	1.033	1.978	
0.130	0.215	0.377	0.633	1.062	2.000	
0.131	0.218	0.386	0.640	1.093	2.112	
0.133	0.221	0.389	0.650	1.109	2.125	
0.136	0.224	0.390	0.656	1.125	2.250	



H&S Manufacturing Co.

CONTRACT MANUFACTURING

Rectangle Tool List	Rectangle Tool List	Rectangle Tool List	Rectangle Tool List	Rectangle Tool List	Rectangle Tool List	Rectangle Tool List
Size	Size	Size	Size	Size	Size	Size
.025 X .280	.080 X .354	.125 X 1.500	.188 X .532	.250 X 1.875	.363 X 1.375	.500 X 2.250
.032 X .150	.080 X .404	.125 X 2.000	.188 X .688	.250 X 1.875	.375 X .500	.505 X .688
.038 X .281	.080 X .482	.125 X 4.000	.192 X 1.370	.250 X 2.000	.375 X .750	.505 X .669
.040 X .250	.080 X .750	.133 X .675	.194 X 1.894	.250 X 3.000	.375 X 1.000	.532 X 1.220
.040 X .130	.082 X 1.125	.134 X .432	.195 X .350	.250 X 4.000	.380 X .515	.545 X .650
.047 X .281	.083 X .394	.136 X .394	.197 X 1.457	.254 X .675	.380 X .520	.550 X .675
.049 X .156	.085 X .190	.140 X .407	.197 X 1.496	.257 X .556	.380 X .846	.556 X 1.000
.050 X .750	.087 X .165	.141 X .675	.200 X .250	.264 X .675	.382 X .400	.575 X .650
.052 X .400	.087 X .173	.145 X .320	.200 X .320	.264 X .875	.390 X 1.375	.575 X .670
.058 X .200	.088 X .344	.145 X .790	.200 X .350	.265 X 1.125	.395 X 1.030	.591 X .787
.063 X .125	.090 X .400	.150 X .250	.200 X .400	.267 X .360	.399 X 2.000	.600 X .625
.063 X .250	.093 X .250	.150 X .270	.200 X .500	.268 X .538	.400 X 2.800	.600 X .700
.063 X .375	.093 X .500	.150 X 1.000	.207 X .472	.270 X .300	.404 X .479	.610 X .821
.063 X .500	.094 X .156	.150 X 2.000	.218 X .500	.272 X .375	.406 X .560	.622 X 1.372
.063 X .625	.094 X .187	.156 X .275	.220 X .175	.281 X .500	.409 X .600	.625 X .725
.064 X 1.00	.094 X .218	.156 X .312	.220 X .320	.281 X .875	.410 X 1.700	.625 X .900
.065 X .250	.095 X .200	.157 X 1.102	.220 X .340	.290 X .875	.414 X .675	.625 X 1.750
.065 X .400	.100 X .220	.158 X .197	.220 X .370	.295 X 1.000	.415 X .750	.625 X 1.750
.066 X .210	.100 X 1.125	.158 X .236	.222 X .500	.312 X .400	.421 X .492	.630 X 2.134
.068 X .260	.105 X .281	.158 X .276	.225 X .443	.312 X .500	.430 X .930	.639 X .669
.068 X .280	.105 X .750	.167 X .250	.232 X .250	.312 X .800	.437 X .750	.676 X 1.980
.068 X .510	.106 X .306	.170 X .350	.236 X .492	.315 X .505	.437 X 1.250	.691 X .700
.068 X .550	.115 X .823	.175 X .220	.244 X .804	.320 X 1.000	.450 X 3.000	.705 X 1.750
.070 X .280	.118 X .236	.175 X .250	.246 X .750	.323 X .750	.470 X .900	.740 X 1.212
.071 X .189	.118 X .256	.175 X .345	.250 X .302	.326 X 2.156	.472 X .670	.750 X 1.000
.071 X .217	.125 X .200	.175 X .625	.250 X .325	.328 X 1.250	.472 X 1.300	.750 X 1.222
.075 X .159	.125 X .250	.180 X .340	.250 X .453	.330 X .504	.477 X .498	FP
.075 X .250	.125 X .312	.182 X 1.00	.250 X .500	.330 X 1.419	.484 X .656	.750 X 1.250
.075 X .375	.125 X .325	.187 X .250	.250 X .520	.332 X .646	.488 X 1.000	.750 X 3.500
.075 X .400	.125 X .350	.187 X .500	.250 X .530	.339 x .675	.500 X .550	.760 X 1.265
.075 X 1.000	.125 X .375	.187 X .515	.250 X .557	.339 X 2.000	.500 X .600	.970 X 1.750
.079 X .134	.125 X .500	.187 X .625	.250 X .890	.341 X .350	.500 X .615	1.224 X
.079 X .138	.125 X .591	.187 X 1.000	.250 X 1.000	.350 X 1.000	.500 X .625	1.372
.080 X .156	.125 X .960	.188 X .312	.250 X 1.250	.354 X .716	.500 X 1.000	
.080 X .276	.125 X 1.000	.188 X .438	.250 X 1.500	.363 X .488	.500 X 1.750	



H&S Manufacturing Co.

CONTRACT MANUFACTURING

Square Tool List
Size
.063
.094
.125
.140
.156
.160

Square Tool List
Size
.187
.196
.223
.250
.252
.254

Square Tool List
Size
.265
.281
.300
.312
.336
.350

Square Tool List
Size
.375
.390
.406
.437
.453
.462

Square Tool List
Size
.490
.500
.531
.563
.625
.660

Square Tool List
Size
.700
.750
.775
.812
.875
.975

Square Tool List
Size
1.000
1.375
1.500
1.750
2.000
3.000

Rectangles with Radius Corners Tool List	Corner Radius
Size	Corner Radius
.158 X .280	.016
.178 X 2.899	.052
.188 X .532	.032
.187 X .418	.015
.187 X .428	.015
.250 X .500	.063
.250 X .750	.056
.250 X 1.570	.090
.265 X .439	.086
.274 X .875	.093
.276 X .551	.063
.300 X .337	.080
.304 X 1.824	.048
.310 X 1.250	.060
.312 X 1.750	.120
.321 X .360	.102
.330 X .350	.080
.334 X 3.000	.062
.338 X .466	.015
.350 X 1.550	.090
.355 X .387	.060
.368 X .710	.033

Rectangles with Radius Corners Tool List	Corner Radius
Size	Corner Radius
.374 X 1.750	.120
.375 X .875	.063
.375 X .950	.020
.392 X 1.750	.120
.400 X .500	.060
.400 X .530	.020
.404 X .479	.010
.416 X 1.600	.140
.420 X .550	.020
.430 X .446	.036
.460 X .760	.015
.470 X .490	.008
.472 X .728	.070
.476 X 2.995	.058
.495 X 1.295	.058
.499 X 1.750	.120
.500 X .710	.125
.500 X 1.000	.125
.500 X 1.300	.062
.500 X 1.650	.125
.511 X 2.990	.120
.520 X 3.250	.094

Rectangles with Radius Corners Tool List	Corner Radius
Size	Corner Radius
.530 X .650	.025
.530 X 1.480	.055
.531 X 1.563	.128
.556 X 1.000	.094
.570 X .790	.063
.600 X .800	.125
.605 X 2.000	.125
.624 X 1.750	.120
.625 X 1.125	.125
.625 X 2.460	.187
.760 X .908	.187
.769 X 2.029	.100
.790 X 1.260	.062
.820 X 1.200	.062
.820 X 1.750	.125
.987 X 1.750	.120
.990 X 2.146	.120
1.147 X 2.880	.060
1.582 X 1.782	.121
1.600 X 1.800	.130
1.752 X 3.996	.148
2.794 X 2.994	.497



H&S Manufacturing Co.

CONTRACT MANUFACTURING

Squares with Radius Corners Tool List	
Size	Corner Radius
.150	.010
.350	.030
.425	.030
.490	.032
.532	.093

Squares with Radius Corners Tool List	
Size	Corner Radius
.556	.094
.791	.443
.600	.090
.625	.094
.750	.090

Squares with Radius Corners Tool List	
Size	Corner Radius
.875	.094
1.120	.120
1.300	.187

Obround Tool List
Size
.032 X .145
.032 X .250
.039 X .098
.048 X .250
.050 X .375
.063 X .250
.063 X .375
.063 X .500
.075 X .425
.080 X .300
.080 X .500
.087 X .204
.088 X .500
.090 X .250
.090 X .750
.093 X .500
.094 X .190
.098 X .125
.100 X .150
.100 X .190
.100 X .250
.100 X .365
.100 X .375
.100 X .450
.100 X .500

Obround Tool List
Size
.100 X .690
.100 X .750
.100 X 1.00
.102 X .750
.104 X .200
.104 X .250
.106 X .375
.109 X .156
.110 X .400
.110 X .630
.116 X .146
.118 X .179
.120 X .200
.120 X .218
.120 X .250
.125 X .156
.125 X .170
.125 X .180
.125 X .188
.125 X .195
.125 X .218
.125 X .250
.125 X .325
.125 X .375
.125 X .425

Obround Tool List
Size
.125 X .437
.125 X .500
.125 X .591
.125 X 1.000
.128 X .375
.130 X .150
.131 X .233
.131 X .375
.131 X .190
.138 X .177
.140 X .165
.140 X .200
.140 X .240
.140 X .312
.140 X .360
.141 X .171
.142 X .394
.144 X .500
.146 X .209
.146 X .303
.150 X .216
.150 X .330
.150 X .375
.152 X .272
.156 X .188

Obround Tool List
Size
.156 X .218
.156 X .222
.156 X .250
.156 X .312
.156 X .356
.156 X .375
.156 X .400
.156 X .500
.156 X .506
.156 X .625
.156 X .625
.161 X .255
.161 X .232
.161 X .236
.162 X .187
.165 X 1.181
.166 X .216
.166 X .250
.166 X .276
.166 X .312
.166 X .416
.166 X 1.00
.169 X .236
.170 X .220
.172 X .203

Obround Tool List
Size
.172 X .250
.172 X .372
.172 X .500
.176 X .236
.177 X .218
.177 X .226
.184 X .254
.185 X .345
.185 X .461
.187 X .250
.187 X .312
.187 X .352
.187 X .375
.187 X .500
.187 X 1.000
.188 X .285
.188 X .438
.188 X .625
.188 X 2.000
.190 X .440
.190 X .500
.191 X .250
.191 X .312
.192 X .212
.192 X .250

Obround Tool List
Size
.195 X .281
.197 X .472
.200 X .500
.200 X .787
.203 X .328
.203 X .375
.203 X .625
.203 X .803
.205 X 1.050
.213 X .275
.213 X .500
.214 X .313
.217 X .295
.218 X .250
.218 X .344
.218 X .406
.219 X .312
.228 X .500
.228 X 1.00
.234 X .609
.236 X .354
.236 X .953
.247 X .365
.250 X .312
.250 X .375

Obround Tool List
Size
.250 X .406
.250 X .430
.250 X .500
.250 X .540
.250 X .585
.250 X .750
.250 X 1.000
.250 X 1.050
.260 X .290
.265 X .305
.265 X .406
.265 X .750
.276 X 1.575
.280 X .400
.280 X .530
.280 X .980
.281 X .344
.281 X .406
.281 X .437
.281 X .500
.285 X .394
.295 X .405
.312 X .405
.312 X .437
.312 X .500



H&S Manufacturing Co.

CONTRACT MANUFACTURING

Obround Tool List
Size
.312 X .562
.330 X .400
.334 X .925
.344 X .500

Obround Tool List
Size
.348 X .948
.350 X .950
.375 X .437
.375 X .500

Obround Tool List
Size
.375 X .750
.375 X .810
.390 X 1.990
.394 X .788

Obround Tool List
Size
.406 X .750
.412 X .530
.479 X .664
.500 X 1.000

Obround Tool List
Size
.520 X .750
.520 X .810
.529 X 1.07
.536 X 1.08

Obround Tool List
Size
.541 X 1.00
.620 X 1.500
.625 X 1.069
.708 X 1.181

Obround Tool List
Size
.750 X 2.000
1.000 X 2.650

Single D Tool List
Size
.193 X .173
.195 X .178
.240 X .203
.250 X .236
.260 X .230
.260 X .235
.260 X .240

Single D Tool List
Size
.281 X .265
.285 X .268
.314 X .283
.314 X .295
.318 X .292
.323 X .295
.323 X .302

Single D Tool List
Size
.375 X .349
.378 X .343
.379 X .364
.380 X .352
.390 X .342
.390 X .354
.442 X .412

Single D Tool List
Size
.470 X .450
.476 X .449
.500 X .455
.500 X .475
.505 X .474
.505 X .481
.515 X .475

Single D Tool List
Size
.520 X .490
.583 X .535
.580 X .555
.602 X .579
.630 X .575
.703 X .663
.830 X .765

Single D Tool List
Size
.830 X .770
.875 X .650
.884 X .830
.898 X .875
1.010 X .975
1.015 X .950
1.140 X

Single D Tool List
Size
1.080
1.140 X
1.105
1.582 X
1.646

Double D Tool List
Size
.185 x .126
.232 x .127
.232 x .130
.254 x .214
.257 x .210

Double D Tool List
Size
.258 x .215
.262 x .213
.267 x .220
.312 x .255
.315 x .293

Double D Tool List
Size
.327 x .277
.344 x .281
.437 x .390
.470 x .400
.503 x .463

Double D Tool List
Size
.512 x .472
.583 x .476
.602 x .540
.615 x .546
.625 x .531

Double D Tool List
Size
.626 x .325
.637 x .537
.642 x .535
.647 x .543
.750 x .687

Double D Tool List
Size
.760 x .640
.765 x .696
.781 x .686
1.140 x
1.105

Double D Tool List
Size
1.360 x
1.140
1.375 x
1.125

Tapping Insert for Punch Press
Size
6-32
4-40
2-56

Tapping Insert for Punch Press
Size
10-32
12-24
M2 x 0.4

Tapping Insert for Punch Press
Size
M3 x 0.5
M2.5 x 0.45
M4 x .7



H&S Manufacturing Co.

CONTRACT MANUFACTURING

Form Down Countersinks		
Degree	Size	Pilot
60°	.116	NO
60°	.165	.131
60°	.242	.184
82°	.178	NO
82°	.180	NO
82°	.180	.120
82°	.210	.145
82°	.230	NO
82°	.230	.136
82°	.230	.140
82°	.235	NO
82°	.250	NO
82°	.250	.121
82°	.280	NO
82°	.280	.166
82°	.280	.190
82°	.280	.213
82°	.290	NO
82°	.290	.222
82°	.302	.160
82°	.345	.166
82°	.345	.229
82°	.350	.156
82°	.350	NO
82°	.370	.185
82°	.370	.189
82°	.370	.221
82°	.375	.175
82°	.385	.221
82°	.390	.272
82°	.395	.213
82°	.395	.229
82°	.401	.263

Form Down Countersinks		
Degree	Size	Pilot
82°	.405	.230
82°	.520	.360
90°	.095	NO
90°	.100	NO
90°	.159	NO
90°	.173	NO
90°	.185	.090
90°	.190	.116
90°	.218	NO
90°	.240	NO
90°	.256	.158
90°	.280	NO
90°	.254	NO
90°	.318	.177
90°	.340	NO
90°	.350	NO
90°	.360	.245
90°	.360	.250
90°	.365	.172
90°	.660	NO
100°	.120	NO
100°	.122	.067
100°	.130	NO
100°	.180	NO
100°	.180	.098
100°	.188	.118
100°	.189	.102
100°	.190	.098
100°	.205	.101
100°	.220	.125
100°	.225	NO
100°	.225	.107
100°	.228	NO

Form Down Countersinks		
Degree	Size	Pilot
100°	.230	NO
100°	.235	NO
100°	.235	.196
100°	.245	.130
100°	.254	NO
100°	.260	NO
100°	.270	NO
100°	.280	NO
100°	.280	.188
100°	.318	NO
100°	.322	.187
100°	.330	.175
100°	.340	NO
100°	.340	.166
100°	.342	.168
100°	.385	.180
100°	.385	.218
100°	.397	.205
120°	.116	NO
120°	.210	.100
120°	.220	.128
120°	.230	NO
120°	.258	.131
120°	.270	.131
120°	.280	.131
120°	.302	.129
120°	.330	NO
120°	.360	.062
120°	.412	.114
120°	.468	.170



H&S Manufacturing Co.

CONTRACT MANUFACTURING

Form Up Countersinks		
Degree	Size	Pilot
60°	.116	NO
60°	.160	.136
60°	.165	.131
60°	.197	.166
82°	.180	.111
82°	.210	.140
82°	.230	.125
82°	.225	NO
82°	.230	NO
82°	.235	.128
82°	.240	.120
82°	.280	NO
82°	.290	.151
82°	.340	.196
82°	.340	.213
82°	.365	.245

Form Up Countersinks		
Degree	Size	Pilot
90°	.159	NO
90°	.180	.090
90°	.200	.101
90°	.220	.106
90°	.257	.125
90°	.276	.213
90°	.278	.185
90°	.300	.240
90°	.320	.250
90°	.382	.190
100°	.190	.098
100°	.230	.131
100°	.235	.125
100°	.235	.196
100°	.260	NO
100°	.280	.131

Form Up Countersinks		
Degree	Size	Pilot
100°	.390	.199
100°	.405	.200
100°	.416	.199
120°	.280	.131
120°	.285	.131
120°	.235	.128
120°	.280	.130
120°	.290	.128
120°	.300	.153
120°	.300	NO
120°	.335	.157



H&S Manufacturing Co.

CONTRACT MANUFACTURING

Form Tooling

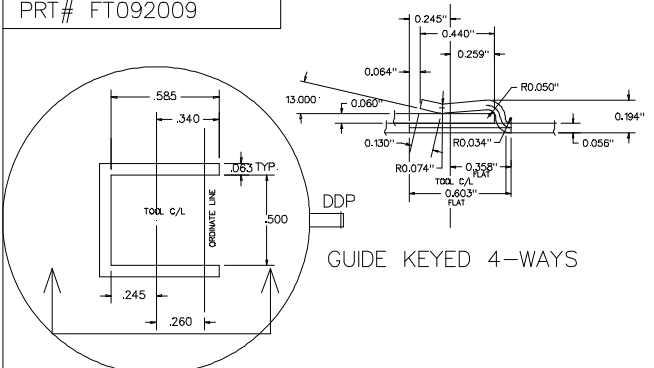
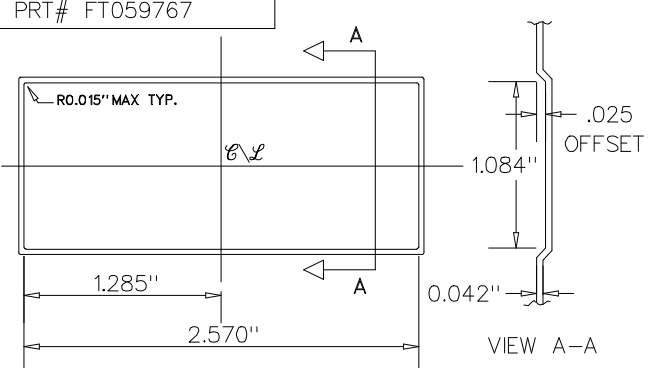
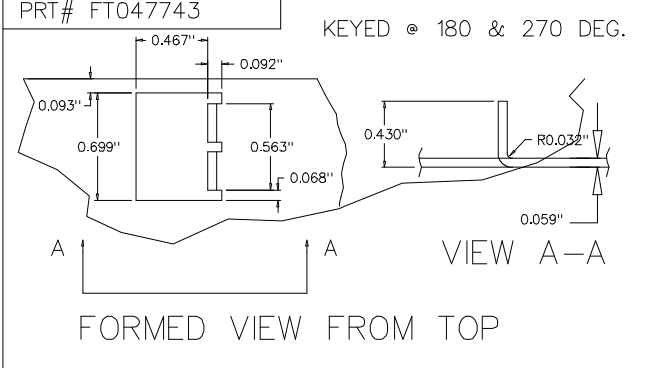
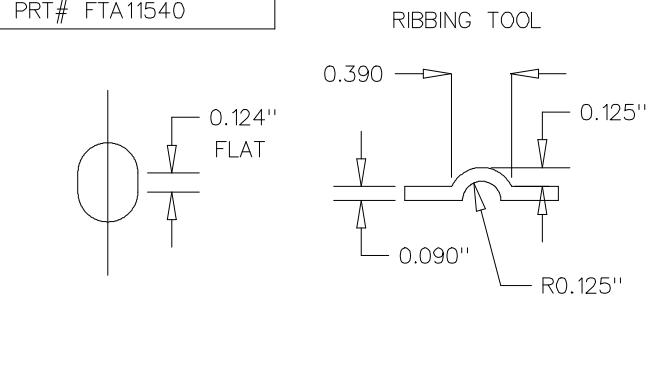
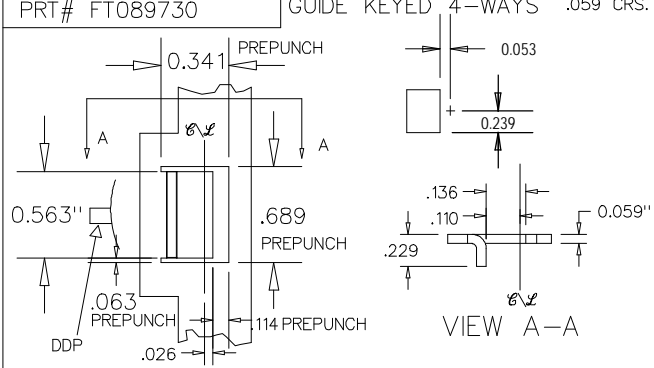
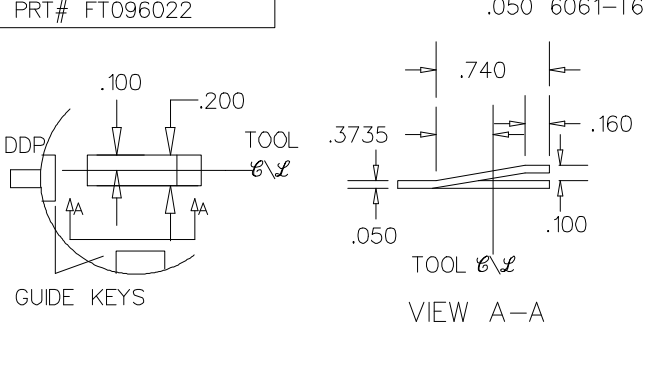
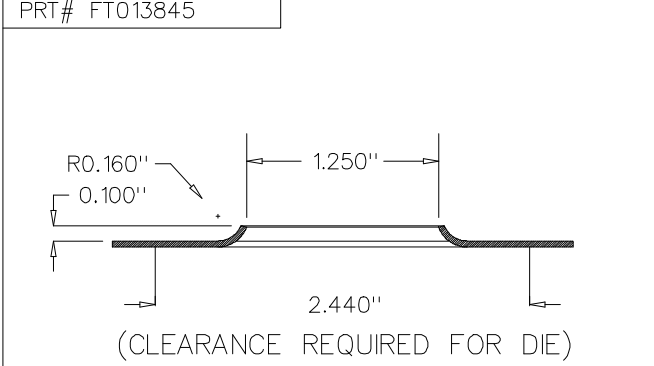
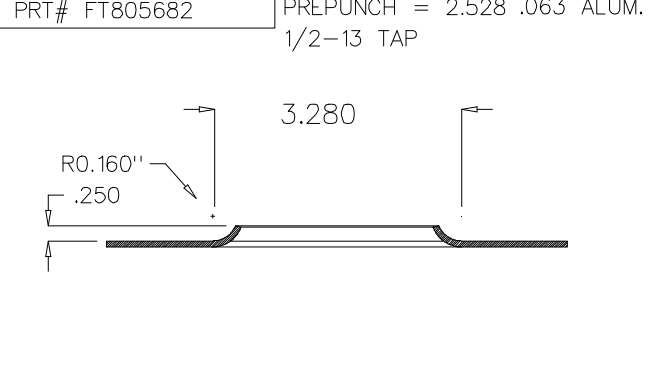
SPT# NONE	TOOL# 09-2009	1 1/4 STAT.	SPT# EMB05-9767	TOOL# 05-9767	3 1/2 STAT.
PRT# FT092009			PRT# FT059767		
SPT# NONE	TOOL# 04-7743	1 1/4 STAT.	SPT# NONE	TOOL# A1154010056	1 1/4 STAT.
PRT# FT047743	<p>KEYED @ 180 & 270 DEG.</p> 		PRT# FTA11540	<p>RIBBING TOOL</p> 	
SPT# NONE	TOOL# 08-9730	1 1/4 STAT.	SPT# NONE	TOOL# 09-6022	1 1/4 STAT.
PRT# FT089730	<p>GUIDE KEYED 4-WAYS .059 CRS.</p> 		PRT# FT096022	<p>.050 6061-T6</p> 	
SPT# NONE	TOOL# 01-3845	3 1/2 STAT.	SPT# NONE	TOOL# 805682	4 1/2 STAT.
PRT# FT013845			PRT# FT805682	<p>PREPUNCH = 2.528 .063 ALUM. 1/2-13 TAP</p> 	



H&S Manufacturing Co.

CONTRACT MANUFACTURING

Form Tooling

SPT# NONE	TOOL# 80-6162	3 1/2 STAT.	SPT# NONE	TOOL# A000-082	2 STAT.
PRT# FT806162	.071 ALUM.		PRT# FT000082		
SPT# NONE	TOOL# 01-3846	3 1/2 STAT.	SPT# NONE	TOOL#	STAT.
PRT# FT013846			PRT#		
SPT# NONE	TOOL#	STAT.	SPT# NONE	TOOL# 21580K	3 1/2 STAT.
PRT#			KEYED ALL 4 WAYS		
			OUBROUND CSK @ EDGE OF SHEET .060 MATL		
SPT# NONE	TOOL# WT2073210	4 1/2 STAT.			
PRT#	.036 CRS				



H&S Manufacturing Co.

CONTRACT MANUFACTURING

Form Tooling

SPT# NONE	TOOL# WT2073210	1 1/4 STAT.	SPT# 10554	TOOL# A2016010554	2" STAT.
PRT#	RIBBING TOOL		PRT#	F/U KNOCKOUT TOOL	
SPT# 01585FU	TOOL# A80041601585	1 1/4 STAT.	SPT	TOOL# A1088010869	3.5" STAT.
F/U MARKING TOOL					
ALWAYS KEY @ 270'					
SPT 01584FD	TOOL# A80040101584	1 1/4 STAT.	SPT# 2127891	TOOL# 2127891	1 1/4 STAT. .063 ALUM
F/D MARKING TOOL			USE W/TOOL #2127892		
ALWAYS KEY @ 270'					
PUNCH PIN @ 270'			FORM TOOL TOOL#2127891		
SPT#	TOOL#	1 1/4 STAT.	C/L		



H&S Manufacturing Co.

CONTRACT MANUFACTURING

Form Tooling

TOOL#	WT2046516
OPERATION 3 TOOL#2	

1 1/4 STATION
.047 THK CRS
ø.125 PIN

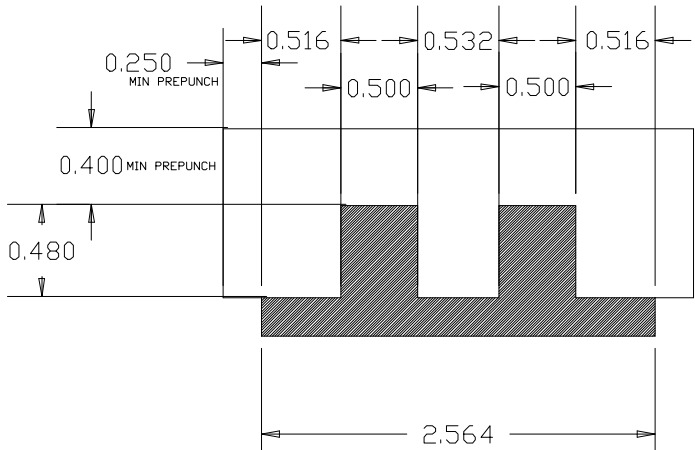
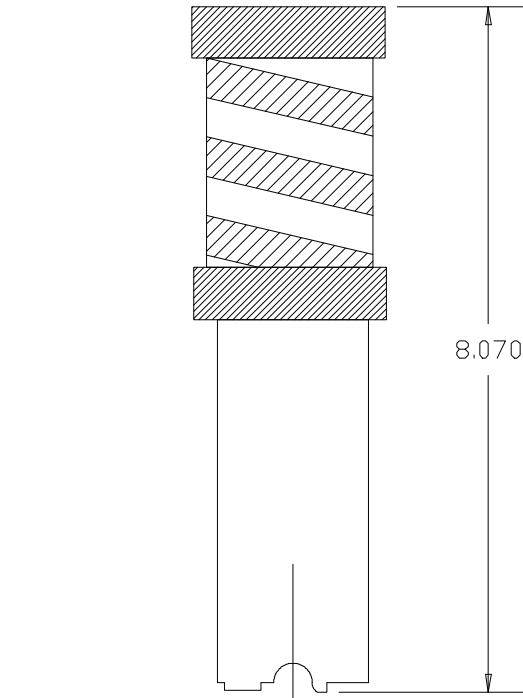

RECOMMENDED CLAMP LOCATION

DDP@270°

C/L

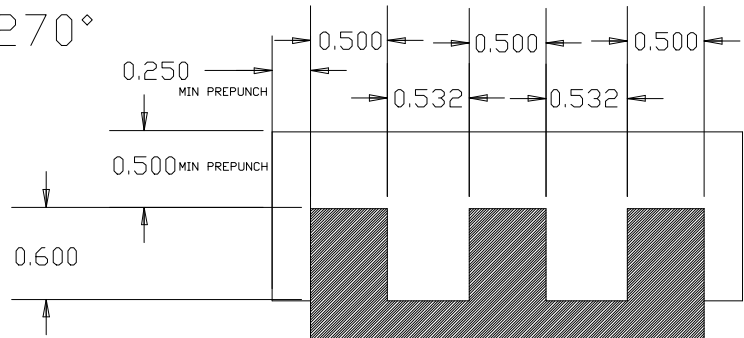

RECOMMENDED CLAMP LOCATION

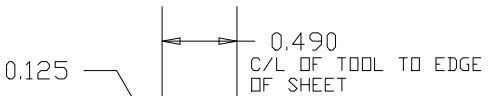

OPERATION 3 TOOL#2



H&S Manufacturing Co.

CONTRACT MANUFACTURING

Form Tooling

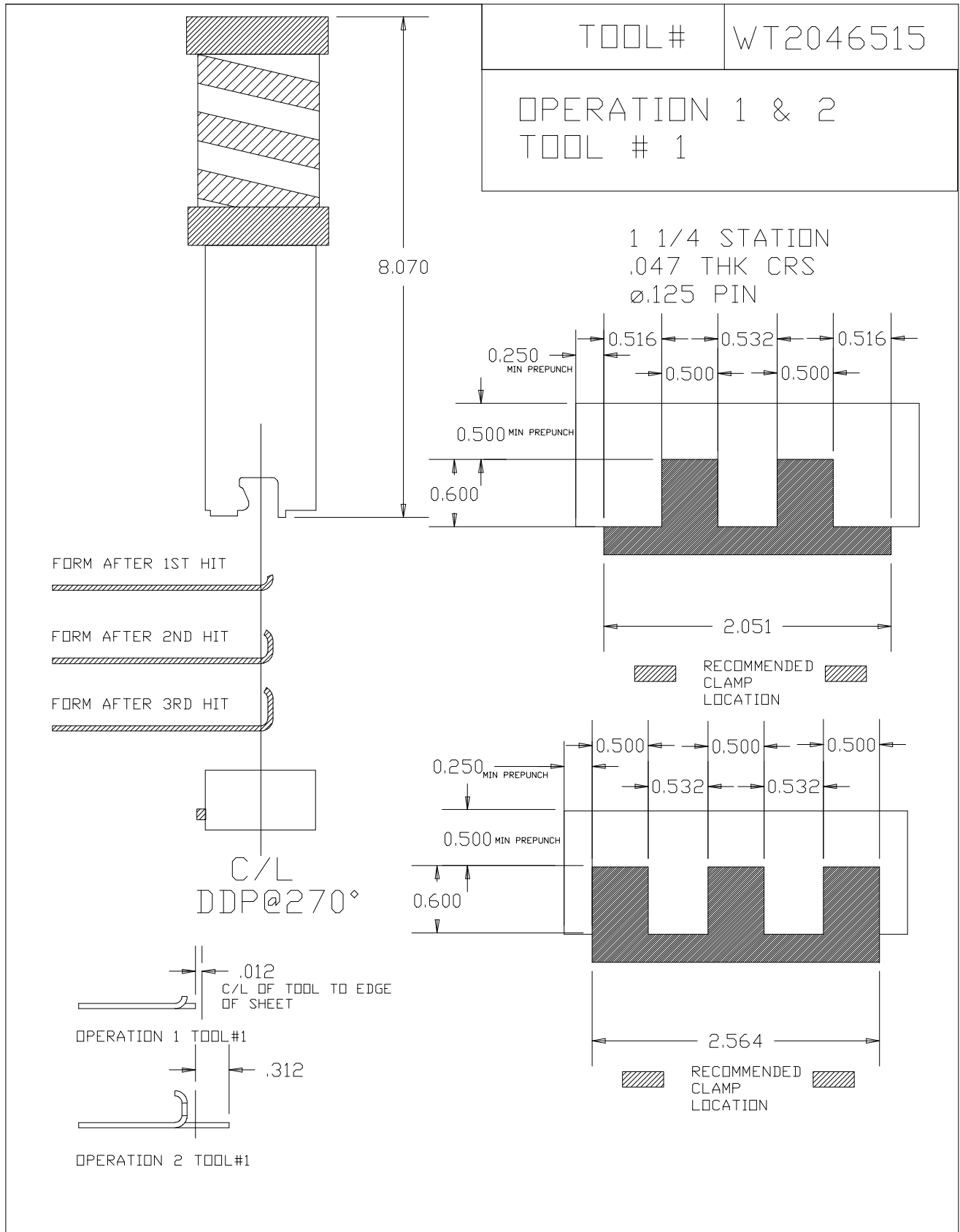



H&S Manufacturing Co.

CONTRACT MANUFACTURING

Form Tooling

SPT# A4004040696	TOOL# A4004040696	1 1/4" STAT.	SPT# A400427-880	TOOL# A400427-880	1 1/4" STAT.
<p>.018 SPRING STEEL</p>			<p>FORM UP FLANGE TOOL</p>		
SPT#	TOOL# A302401-0031	1 1/4" STAT.	SPT# 01225FU	TOOL# A20341101225	1 1/4" STAT.
<p>FORM UP EAR TOOL FORMING ONLY</p>					
SPT#	TOOL# SI00430-0655	1 1/4" STAT.	SPT# A10043002392	TOOL# A10043002392	1 1/4" STAT.
<p>F/D OBROUND CSK 82°</p>			<p>F/D OBROUND CSK 82°</p>		
SPT#	TOOL# SI00430-01772	1 1/4" STAT.	SPT# WT228833-10	TOOL# 228833-10	1 1/4" STAT.
<p>F/D OBROUND CSK 100°</p>			<p>KEYED @ 0°, 90°, 180°, 270°</p> <p>FOR .040 ALUM</p>		



H&S Manufacturing Co.

CONTRACT MANUFACTURING

Form Tooling

SPT#	TOOL# WT.117494-10	1 1/4" STAT.	SPT#	TOOL# WT.117494-30	1 1/4" STAT.
1/16 CHARACTER FORM DOWN STAMP FOR USE ON P/N A9782-00001 REV X4		.036 C.R.S.	1/16 CHARACTER FORM DOWN STAMP FOR USE ON P/N A9782-00001 REV X4		.036 C.R.S.
SPT#	TOOL# WT.117494-20	1 1/4" STAT.	SPT#	TOOL# WT.144152-10	1 1/4" STAT.
1/16 CHARACTER FORM DOWN STAMP FOR USE ON P/N A9782-00001 REV X4		.036 C.R.S.	1/16 CHARACTER FORM DOWN STAMP FOR USE ON P/N A9784-00001-10 REV X2		.036 C.R.S.
SPT#	TOOL# WT#176822-10	1 1/4" STAT.	SPT# HPL0G0	TOOL# A80040101748	1 1/4" STAT.
1/16 CHARACTER FORM DOWN STAMP FOR USE ON P/N A9784-00001 REV B		.036 C.R.S.	FORM DOWN STAMP KEYED 4-WAY		
SPT#	TOOL#	STAT.	SPT#	TOOL#	STAT.



H&S Manufacturing Co.

CONTRACT MANUFACTURING

Form Tooling

FORM DOWN STAMPS FOR H.P. AB290-00001 REV - 1 1/4" STAT.

KEYED 4-WAY

.036 C.R.S.

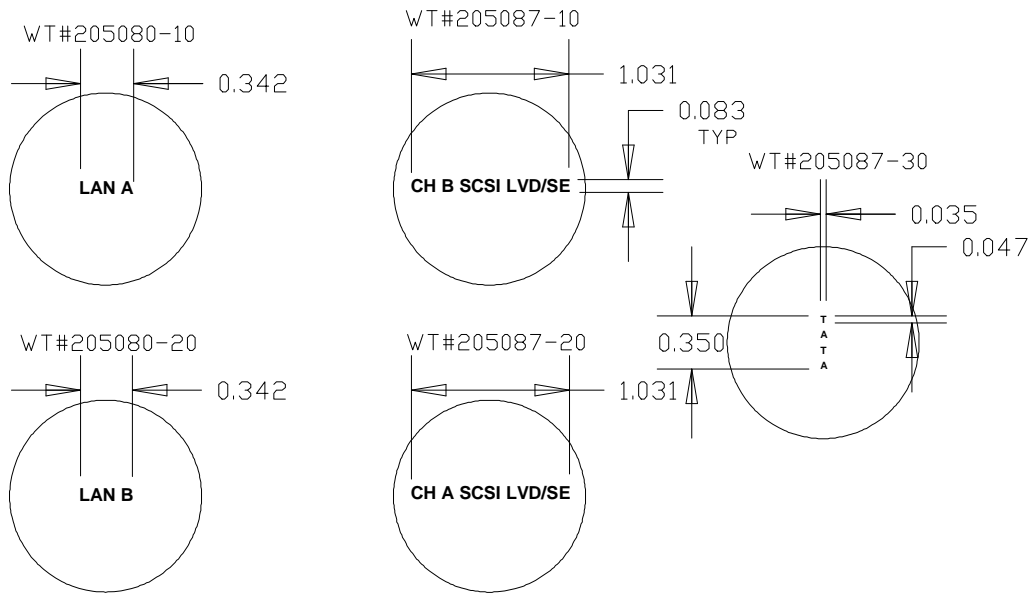

SPT# TOOL# A10861001268 STAT. 2"

FOR A6866-00012 D

.050 ALUM

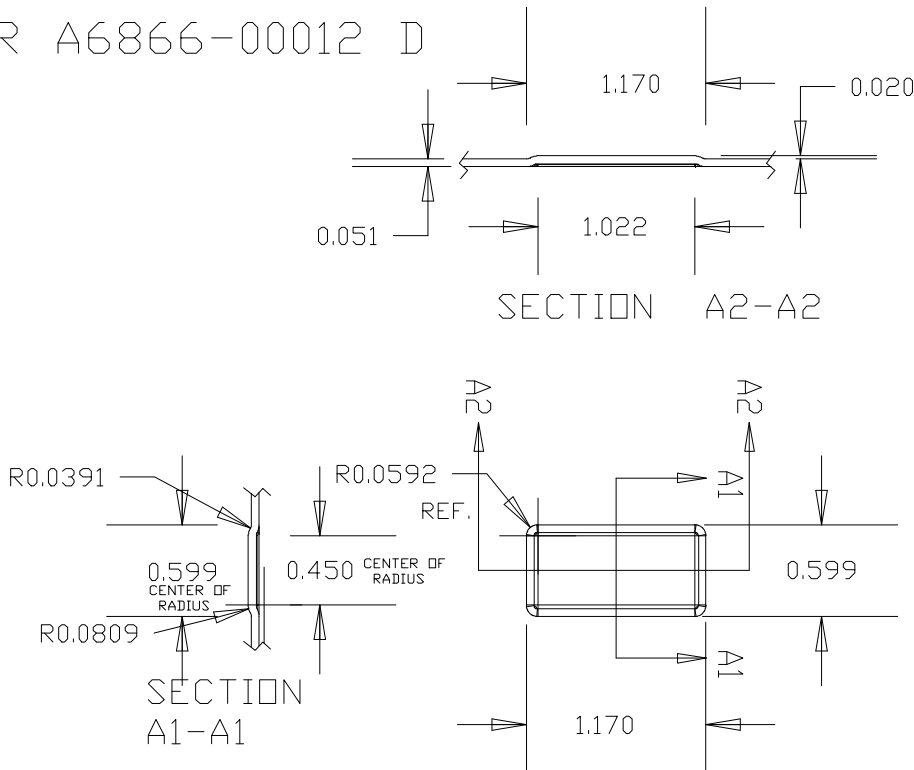



H&S Manufacturing Co.

CONTRACT MANUFACTURING

Form Tooling

SPT# A10860301493		TOOL# A10860301493		2" STAT.	
FORM-UP RECT. DIMPLE FOR H.P. "TUG PS TRAY ASSY"					
SPT# A3024010119	TOOL# A3024010119	1 1/4" STAT.	SPT# A10840801562	TOOL# A10840801562	1 1/4" STAT.
FOR P/N 198685A-01 3		.018 C.R.S.	FOR P/N 198685A-01 3		.018 C.R.S.
SPT#	TOOL#	STAT.			



H&S Manufacturing Co.

CONTRACT MANUFACTURING

Form Tooling

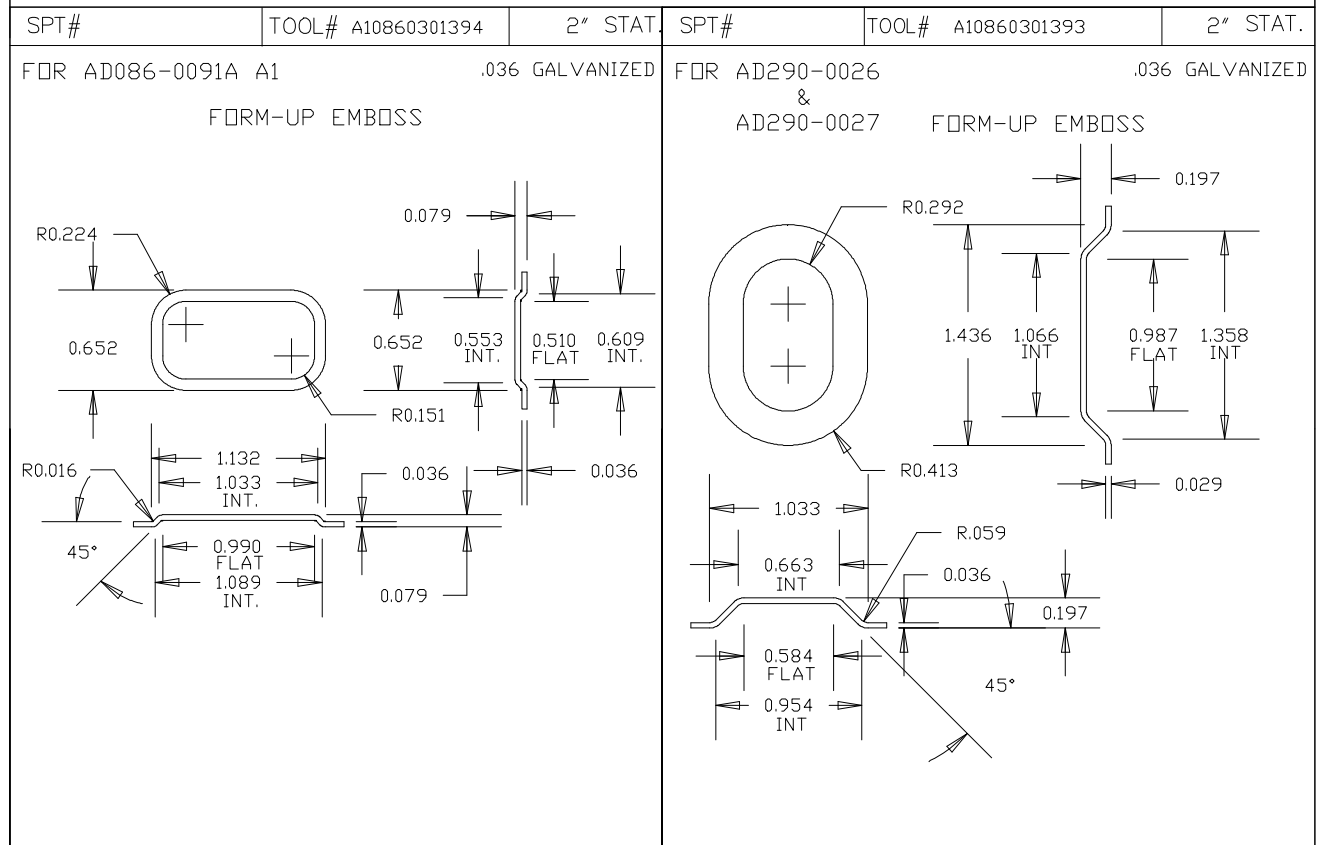
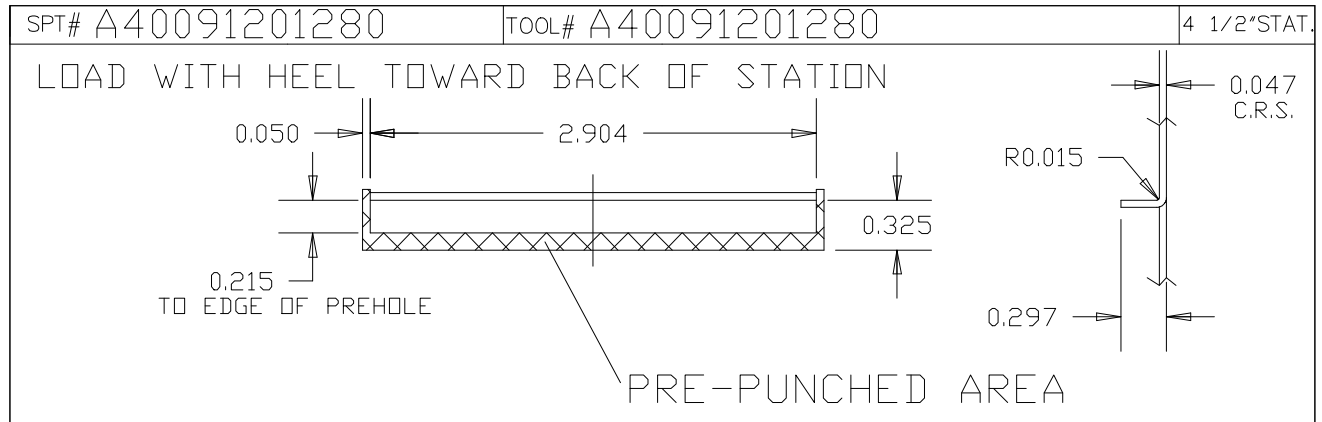

SPT#	TOOL#	STAT.	SPT#	TOOL#	STAT.

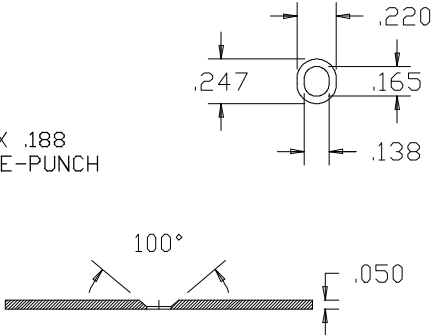
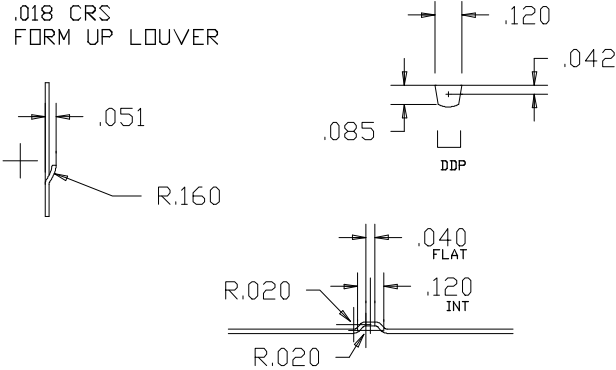
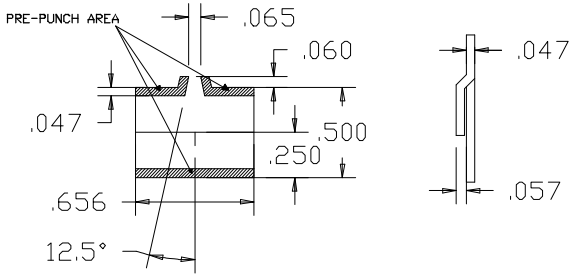
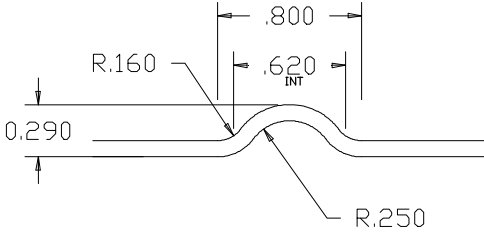
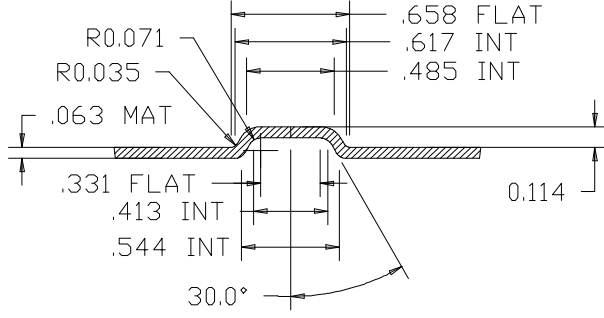
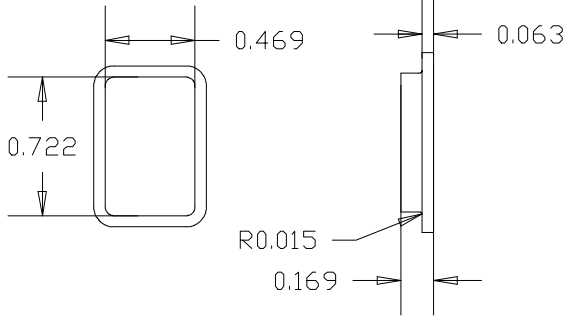

Form Tooling

<p>TOOL # S100430-02175</p>	<p>1/4 STATION</p>	<p>TOOL # A3024010119</p>	<p>1/4 STATION</p>
<p>.050 ALUM FORM DOWN DBL CSK</p>  <p>USING .158 X .188 LASERED PRE-PUNCH</p>		<p>.018 CRS FORM UP LOUVER</p> 	
<p>TOOL # A2016040826</p>	<p>2 STATION</p>	<p>TOOL # S115605-0205</p>	<p>1/4 STATION</p>
<p>.047 CRS FORM UP KNOCKOUT</p>  <p>PRE-PUNCH AREA</p>		<p>.090 ALUM FORM UP PROGRESSIVE RIB</p> 	
<p>TOOL # S101402-01795</p>	<p>1/4 STATION</p>	<p>TOOL # A0016040247</p>	<p>1/4 STATION</p>
<p>FORM UP .651 DIA DIMPLE TOOL</p> 		<p>.063 ALUM</p> 	



H&S Manufacturing Co.

CONTRACT MANUFACTURING

Form Tooling

SPT# A0018110201	TOOL# A0018110201	3 1/2" STAT.	SPT# S118417-0052	TOOL# S118417-0052	1 1/4" STAT.
FOR H.P. AD290-XXXX		.036 GALVANIZED	HINGE TOOL		.047 CRS
SPT#	TOOL#	1 1/4" STAT.	SPT#	TOOL#	1 1/4" STAT.
SPT#	TOOL#	STAT.	SPT#	TOOL#	STAT.
SPT#	TOOL#	STAT.	SPT#	TOOL#	STAT.



H&S Manufacturing Co.

CONTRACT MANUFACTURING

Louvers

SPT# NONE	TOOL# A2300-205	4 1/2 STAT.	SPT# NONE	TOOL# A300-051	4 1/2 STAT.
PRT# FT300205	KEYED ALL 4 WAYS		PRT# FT300051	KEYED ALL 4 WAYS	
SPT#	TOOL# WT452228-10	4 1/2 STAT.	SPT# NONE	TOOL# WT454343-10	4 1/2 STAT.
PRT#	KEYED 4 WAY		PRT#	NOTE DIE IS RELIEVED FOR A POCKET. START @ BOTTOM OF SHEET MOVE OUT AWAY FROM CLAMPS	
SPT# NONE	TOOL#	STAT.	SPT# NONE	TOOL#	STAT.
PRT#			PRT#		
SPT# NONE	TOOL#	STAT.	SPT# NONE	TOOL#	STAT.
PRT#			PRT#		



H&S Manufacturing Co.

CONTRACT MANUFACTURING

Shear Button

SPT# NONE	TOOL# A1072010159	1/2 STAT.	SPT# NONE	TOOL# A203-218	1 1/4 STAT.
PRT# SB107201	.057 CRS		PRT# SB203218		
SPT# NONE	TOOL# A203-122	1 1/4 STAT.	SPT# NONE	TOOL# PA2032020037	1/2 STAT.
PRT# SB203122			PRT# SB203202		
SPT# NONE	TOOL# A2038010742	3 1/2 STAT	SPT# NONE	TOOL# A2036020741	2'' STAT
SPT# NONE	TOOL# A203602-0704	3 1/2 STAT	SPT# NONE	TOOL# A2036060703	2'' STAT
PRT# A236207			PRT# A236607		



H&S Manufacturing Co.

CONTRACT MANUFACTURING

Shear Button

SPT# 125SQHS	TOOL#	1/2 STAT.	SPT# 125RDHS	TOOL#A203-122-119	1/2 STAT.
SQUARE HALF SHEAR			ROUND HALF SHEAR		
SPT# S203201-0118	TOOL#S203201-0118	1/2 STAT.	SPT# 180RDHS	TOOL# W.T.# 2164236	1 1/4 STAT.
PRT#		.057 CRS	PRT#	STRIPPER RELIEVED AS SHOWN	
ROUND HALF SHEAR					
SPT# HS275	TOOL#WT#2662095	1 1/4 STAT	SPT# 110RDHS	TOOL#W.T.# 2164237	1 1/4 STAT
		.006 CL		STRIPPER RELIEVED AS SHOWN	
ROUND HALF SHEAR					
SPT#	TOOL#S203411-0406	1 1/4 STAT	SPT# 155RDHS	TOOL#W.T.# 2164238	1 1/4 STAT
PRT#			PRT#	STRIPPER RELIEVED AS SHOWN	



H&S Manufacturing Co.

CONTRACT MANUFACTURING

Shear Button

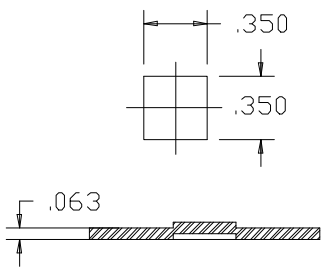
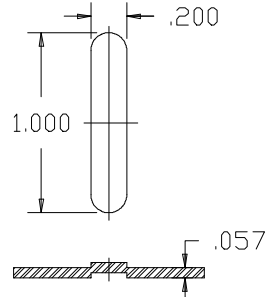
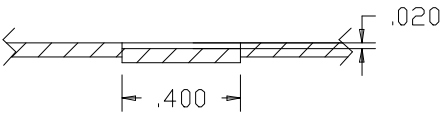
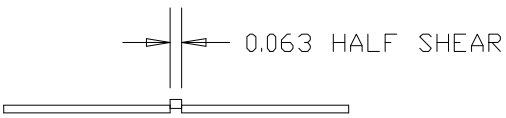
TOOL # S203411-0743	1¼ STATION	TOOL # WT692520-10	1¼ STATION
<p>.063 ALUM FORM UP .350 HALF SHEAR</p> 		<p>.057 CRS FORM UP OBL HALF SHEAR</p> 	
TOOL # WT465002-50	1¼ STATION	TOOL # S203201-0840	1¼ STATION
<p>.047 C.R.S. FORM-DOWN .400 DIA. HALF SHEAR</p> 		<p>.048 CRS</p> 	



H&S Manufacturing Co.

CONTRACT MANUFACTURING

Lances

SPT# NONE PRT# L045146	TOOL# WT045146 .057 THICK	1 1/4 STAT.	SPT# NONE PRT# L114061	TOOL# A114-401-0061 .041 THICK	1 1/4 STAT.
SPT# NONE PRT# L114XXX	TOOL# A114-XXX TOOL# A114-061 .041 THICK 2 SETS	1 1/4 STAT.	SPT# NONE PRT# L4040003	TOOL# A117404-0003	1 1/4 STAT.
SPT# NONE PRT# L802114	TOOL# 80-2114 .075 THICK	1 1/4 STAT.	SPT# NONE PRT# L825630	TOOL# WT825630 .075 THICK	1 1/4 STAT.
SPT# NONE PRT# L4040005	TOOL# A117402-0046	1 1/4 STAT.	SPT# lan4x770 PRT# L114418	TOOL# A114418-0395	1 1/4 STAT.



H&S Manufacturing Co.

CONTRACT MANUFACTURING

Lances

SPT# NONE	TOOL# A1174020046	1 1/4 STAT.	SPT#S113401	TOOL# S113401-0058	1 1/4 STAT.	
PRT# L1174246		<p>VIEW C-C</p> <p>CONVEX CABINET</p>		<p>VIEW A-A</p>		
SPT# 74020108	TOOL# 74020108	1 1/4 STAT.	SPT# 44030216	TOOL# S114403-0216	1 1/4 STAT.	
<p>VIEW C-C</p>		<p>VIEW C-C</p>		<p>45°</p>		
SPT# 44030272	TOOL# S114403-0272	1 1/4 STAT.	SPT# 84160814	TOOL# A1084160814	1 1/4 STAT.	
<p>.459FLAT</p>		<p>R0.314</p>		<p>.080 ALUM</p> <p>DDP</p>		
SPT# 4403-0273	TOOL# S114403-0273	1 1/4 STAT.	CUSTOMER PREHOLE			
<p>45°</p>		<p>.062 THK</p> <p>45°</p>		<p>R0.0240</p>		



H&S Manufacturing Co.

CONTRACT MANUFACTURING

Lances

SPT# 4403-0271	TOOL# S114403-0271	1 1/4 STAT.	SPT# A1144020796	TOOL# A1144020796	1 1/4 STAT.
PRT# NONE			PRT# NONE		
SPT#	TOOL# S113401-0071	1 1/4 STAT.			
SPT#	TOOL# WT207992-10	1 1/4 STAT.	<p data-bbox="186 1207 511 1239">NO PRE-HOLES REQUIRED</p> <p data-bbox="1323 1207 1469 1260">.048 C.R.S. .008 CL.</p>		



H&S Manufacturing Co.

CONTRACT MANUFACTURING

Lances

SPT# NONE	TOOL# WT222410-10	1 1/4 STAT.	SPT# NONE	TOOL# S114403-0701	1 1/4 STAT.
PRT#		.036 C.R.S.	PRT#		
SPT# NONE	TOOL# S114403-0711	1 1/4 STAT.	SPT# NONE	TOOL# A1174130164	1 1/4 STAT.
PRT#			PRT#		
<p>FDR A4856-00042 D</p>			<p>FDR 695-9151-001 C</p>		
SPT#	TOOL# S114403-0797	1 1/4 STAT.	SPT# S□465002-40	TOOL# S□465002-40	1 1/4 STAT.
PRT#			PRT#		.047 C.R.S.
			<p>KEYED 4-WAYS</p> <p>LANCE & FORM DOWN TAB</p>		
SPT# NONE	TOOL#	1 1/4 STAT.	SPT#	TOOL# S117402-0050	1 1/4 STAT.
PRT#			PRT#		



Lances

TOOL # S114403-01125	1¼ STATION	TOOL # A40142001602	1¼ STATION
<p>.048 CRS FORM UP LANCE</p>	<p>.039 ALUM FORM UP OPEN LANCE</p>		
<p>TOOL # S114403-01126</p>	<p>1¼ STATION</p>		
<p>.060 CRS FORM UP LANCE</p>			



Extrusions

SPT# NONE	TOOL# A0004050330	1 1/4 STAT.	SPT# NONE	TOOL# A0004050337	1 1/4 STAT.
PRT# EX000405			PRT# EX050337		
SPT# NONE	TOOL#	1 1/4 STAT.	SPT# NONE	TOOL#	1 1/4 STAT.
PRT#	.125 EXRU FOR .057 / .120 EXRU FOR .047		PRT#		
SPT# NONE	TOOL#	1 1/4 STAT.	SPT# NONE	TOOL#	1 1/4 STAT.
PRT#			PRT#		
SPT# NONE	TOOL#	1 1/4 STAT.	SPT# NONE	TOOL#	1 1/4 STAT.
PRT#			PRT#		



Extrusions

SPT# 2145574	TOOL# 2145574	1 1/4" STAT.	SPT#	TOOL# A00041301224	1 1/4" STAT.
<p>F/U EXTRUSION</p>			<p>F/D</p>		
SPT#	TOOL# S000413-0761	1 1/4" STAT.	SPT#	TOOL# S000413-0021	1 1/4" STAT.
<p>F/D</p>			<p>F/D</p>		
SPT# WT366156-20	TOOL# WT366156-20	1 1/4" STAT.	SPT# WT366156-10	TOOL# WT366156-10	1 1/4" STAT.
<p>FORM-UP EXTRUSION FOR .059 C.R.S.</p>		<p>USE FOR M3 X 0.5 ROLL-FORM</p>	<p>FORM-UP EXTRUSION FOR .036 C.R.S.</p>		<p>USE FOR M3 X 0.5 ROLL-FORM</p>
SPT# WT387910-10	TOOL# WT387910-10	1 1/4" STAT.	.051 FORM UP EXTRU. 1/4" STATION		
<p>FORM-UP EXTRUSION FOR .059 C.R.S.</p>		<p>USE FOR M4 X 0.7 ROLL-FORM</p>	<p>.012 CRS</p> <p>.015 DIA. PRE HOLE REQUIRED WITH LASER</p>		



H&S Manufacturing Co.

CONTRACT MANUFACTURING

Card Guides

SPT# CG095997	TOOL# 09-5997	4 1/2 STAT.	SPT# NONE	TOOL# 09-5999	4 1/2 STAT.
PRT# CG095997	.048 CRS.		PRT# CG095999	.048 CRS.	
			BOT DIE FOR 16GA IS TOOL # WT859690 .400 flat for 16ga 		
SPT# NONE	TOOL# 09-6136	4 1/2 STAT.	SPT# NONE	TOOL# A003602-0072	2 STAT.
PRT# CG096136	.050 CRS.		PRT# CG641500	.042 CRS.	
SPT# NONE	TOOL# .074X1.750	3 1/2 STAT.	SPT# NONE	TOOL# A003801-0124	3 1/2 STAT.
PRT# CG74175	.060 ALUM.		PRT# CG110280	.063 ALUM.	
.400 flat for 16ga TOOL# A003801-0101 					
SPT# NONE	TOOL# A003901-0120	4 1/2 STAT.	SPT# 38010153	TOOL# A0038010153	3 1/2 STAT.
PRT# CG641500	.057 CRS.				



H&S Manufacturing Co.

CONTRACT MANUFACTURING

Card Guides

SPT# 36050128	TOOL# A0036050128	2" STAT.	SPT# 36050129	TOOL# A0036050129	2" STAT.
<p>SPACING VERICALLY FROM CENTER TO CENTER OF CARD GUIDES IS 1.870 MIN</p>		<p>SPACING VERICALLY FROM CENTER TO CENTER OF CARD GUIDES IS 1.870 MIN</p>			
SPT# 38010410	TOOL# A0038010410	3 1/2" STAT.	SPT# 39010130	TOOL# A0039010130	4 1/2" STAT.
		<p>SPACING VERICALLY FROM CENTER TO CENTER OF CARD GUIDES IS 3.870 MIN</p>			
SPT# 36050188	TOOL# A0036050188	2" STAT.	SPT# 36080415	TOOL# A0036080415	2" STAT.
<p>SPACING VERICALLY FROM CENTER TO CENTER OF CARD GUIDES IS 1.870 MIN</p>		<p>PREHOLE REQ'D 1.000 MIN DISTANCE VERTICALLY</p>			
SPT# 38010124	TOOL# A0038010124	3 1/2" STAT.	SPT# 36080416	TOOL# A0036080416	2" STAT.
<p>SPACING VERICALLY FROM CENTER TO CENTER OF CARD GUIDES IS 3.500 MIN</p>		<p>PREHOLE REQ'D 1.000 MIN DISTANCE VERTICALLY</p>			

2913 SINGLETON - P.O. BOX 1515 - ROWLETT, TEXAS 75030-1515

Phone (972) 475-4747 - FAX (972) 475-6155

website: www.hsmfg.com



H&S Manufacturing Co.

CONTRACT MANUFACTURING

Card Guides

SPT#39010457	TOOL#A0039010457	4.50" STAT.	SPT# 36080427	TOOL# A0036080427	2" STAT.
PREHOLE REQ'D 1.000 MIN DISTANCE VERTICALLY					
SPT# A003602-0134	TOOL#	2" STAT.	SPT#	TOOL#	STAT.
SPT#	TOOL#	STAT.	SPT#	TOOL#	STAT.
SPT# A0039010613	TOOL# A0039010613	4 1/2 STAT.			
FOR AD290-0033A A1 OR AD290-0034A A1			.036 GALVANIZED		



Pedestal Dies For Dimples

SPT# NONE PRT# PD553015	TOOL# A553-0156 .006 CLR.	1/2 STAT.	SPT# NONE PRT# PD073446	TOOL# 07-3446 .006 CLR.	1/2 STAT.
SPT# NONE PRT# PD054792	TOOL# 05-4792 .031 5052-H32 .006 CLR.	1/2 STAT.	SPT# NONE PRT# 433125PD	TOOL# .024 CRS	1 1/4" STAT.
			<p>PEDESTAL DIE ø.250 DIE ONLY W/.006 CLEARANCE</p>		
SPT# WT2115015 PRT#	TOOL# WT2115015 PEDESTAL DIE ONLY ø.250 W/.004 CLEAR. DIE ONLY	1 1/4" STAT.	SPT# WT2064264 PRT#	TOOL# WT2064264 PEDESTAL DIE W/.010 CLEARANCE ø.213 THRU DIE ONLY	1 1/4" STAT. .063 ALUM
SPT#	TOOL# WT375753-20 .048 GALV.	1 1/4" STAT.	SPT# A55341001506	TOOL# A55341001506 .020 COPPER	1 1/4" STAT.
			<p>ROUND PEDESTAL DIE FOR DIMPLE TOOL# S101401-01138</p>		



Pedestal Dies For Dimples

TOOL # WT646413-10	1/2 STATION	TOOL # WT637426-10	1/2 STATION
<p>.018 COPPER .110 PEDESTAL</p>		<p>.015 COPPER .126 PEDESTAL</p>	
TOOL # WT638206-20	1/2 STATION		
<p>.020 COPPER .125 PEDESTAL</p>			



H&S Manufacturing Co.

CONTRACT MANUFACTURING

Dimples

SPT# NONE	TOOL# 05-4791	1 1/4 STAT.	SPT# NONE	TOOL# 08-3208	1 1/4 STAT.
PRT# D054791	PEDESTAL DIE FOR DIMPLE .032 THK.		PRT# D083208	PEDESTAL DIE FOR DIMPLE .060 THK.	
SPT# NONE	TOOL# 09-6021	1 1/4 STAT.	SPT# NONE	TOOL# SEE BELOW	1 1/4 STAT.
PRT# D096021	.048 THK.		PRT# D4010311	A101-311 FOR .032 THK S101401-0961 FOR .050 THK	
SPT# NONE	TOOL# A1014040470	1 1/4 STAT.	SPT# NONE	TOOL# A1014040471	1 1/4 STAT.
PRT# D4040470	.032 THK.		PRT# D4040471	.025 THK.	
SPT# NONE	TOOL# A1016010293	2" STAT.	SPT# NONE	TOOL# A1016010294	2" STAT.
PRT# D6010293	PEDESTAL DIE FOR DIMPLE IS 1 1/4" STATION .048 THK.		PRT# D6010294	PEDESTAL DIE FOR DIMPLE IS 1 1/4" STATION .048 THK.	



H&S Manufacturing Co.

CONTRACT MANUFACTURING

Dimples

SPT# NONE	TOOL# 633-7334	1 1/4 STAT.	SPT# NONE	TOOL# WT045745	1 1/4 STAT.
PRT# D6337334		.032 THK.	PRT# D045745		.032 THK.
SPT# NONE	TOOL# A107201-0159	1/2 STAT.	SPT# NONE	TOOL# 41279	1 1/4 STAT.
PRT# D2010159		.029 THK.	PRT# D41279		.063 THK.
SPT# NONE	TOOL# A101-184	1 1/4 STAT.	SPT# NONE	TOOL# 42181	1 1/4 STAT.
PRT# D101184		.040 THK.	PRT# D42181	PEDESTAL DIE FOR DIMPLE .032 THK.	
SPT# NONE	TOOL# 49793	1 1/4 STAT.	SPT# NONE	TOOL# A101404-0564	1 1/4 STAT.
PRT# D49793		.060 THK.	PRT# D4040564		.060 THK.



H&S Manufacturing Co.

CONTRACT MANUFACTURING

Dimples

SPT# NONE	TOOL#	1 1/4 STAT.	SPT# 74020606	TOOL# A107402-0606	1 1/4 STAT.
PRT#		.047	PRT#		
			<p>TOOL RELIEVED TO ACCOMMODATE .468 CENTERS</p>		
SPT# WT2091617	TOOL# WT2091617	1 1/4 STAT.	SPT# S101413	TOOL# S101413-0020	1 1/4 STAT.
PRT#		.036	PRT#		
			<p>EMBOSS</p>		
SPT# T2120770	TOOL# WT2120770	1 1/4 STAT.	SPT# WT22883-10	TOOL#	1 1/4 STAT.
PRT#			PRT#		
SPT# A101602-01657	TOOL# A101602-01657	2" STAT.	SPT# A1072020722	TOOL# A1072020722	1 1/4 STAT.
PRT#		.117 CRS	PRT#		.050 GALV.
FORM UP DIMPLE			FORM DOWN DIMPLE		



H&S Manufacturing Co.

CONTRACT MANUFACTURING

Dimples

SPT# NONE	TOOL# WT144904-10	1 1/4 STAT.	SPT# S108402-0003	TOOL# S108402-0003	1 1/4 STAT.
PRT#			PRT#		
FORM-UP HALF DIMPLE			FORM-UP OBLONG DIMPLE		
SPT#	TOOL# S101413-0947	1 1/4 STAT.	SPT#	TOOL# A101426001982	1 1/4 STAT.
PRT#			PRT#		
FORM-UP DIMPLE			FORM UP ROUND DIMPLE FOR A6866-00014 B		
SPT#	TOOL# S101401-0855	1 1/4 STAT.	SPT#	TOOL# WT336206-10	1 1/4 STAT.
PRT#			PRT#		
FORM UP ROUND DIMPLE FOR 400-1169-600 B					



H&S Manufacturing Co.

CONTRACT MANUFACTURING

Dimples

SPT# NONE	TOOL# WT375753-10	1 1/4 STAT.	SPT#	TOOL# S101402-01119	1 1/4 STAT.
PRT#		.048 GALV.	PRT#		FOR .063 ALUM
USE PEDESTAL DIE WT375753-20 FOR 460-004-969 K 1467 A					
SPT#	TOOL# A101413-01116	1 1/4 STAT.	SPT#	TOOL# S101401-01138	1 1/4 STAT.
		FOR .063 ALUM			.020 COPPER
			FORM UP ROUND DIMPLE		
SPT#	TOOL# A108402-01263	1 1/4 STAT.	SPT#	TOOL# A108610-01264	2" STAT.
		.025 COPPER			.025 COPPER
NAT'L TOOLING FORM UP DIMPLE			NAT'L TOOLING FORM-UP OBLONG EMBOSS		

2913 SINGLETON - P.O. BOX 1515 - ROWLETT, TEXAS 75030-1515

Phone (972) 475-4747 - FAX (972) 475-6155

website: www.hsmfg.com



H&S Manufacturing Co.

CONTRACT MANUFACTURING

Dimples

SPT# NONE	TOOL# S101401-01074	1 1/4 STAT.	SPT# A10841601391	TOOL# A10841601391	1 1/4 STAT.
<p>FDR AD290-0039A A1 .036 GALVANIZED</p> <p>FORM-UP ROUND DIMPLE</p>			<p>FDR AD290-0040A A1 .036 GALVANIZED</p> <p>EDGE OF SHEET OR PRE-HOLE</p>		
SPT# S101404-01159	TOOL# S101404-01159	1 1/4 STAT.	SPT# NONE	TOOL# WT608632-10	1 1/4 STAT.
<p>FDR AD290-0024A OR AD290-0029A .036 GALVANIZED</p>			<p>FDR 209-175-315-103 A .050 2024-Q</p>		
SPT#	TOOL# A10841201556	1 1/4 STAT.	SPT#	TOOL# A10841201557	1 1/4 STAT.
<p>FDR 197533C-01 1 .015 C.R.S.</p>			<p>FDR 197533C-01 1 .015 C.R.S.</p>		
SPT#	TOOL#	2" STAT.	SPT#	TOOL#	1 1/4 STAT.
PRT#					

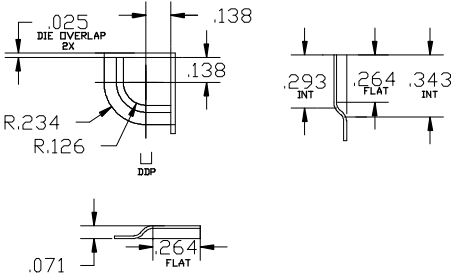
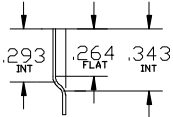
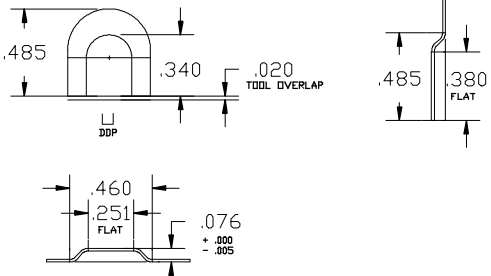
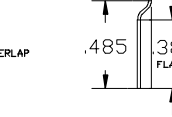
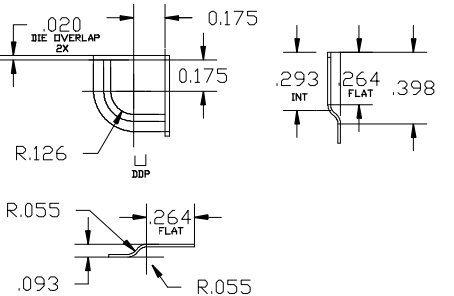
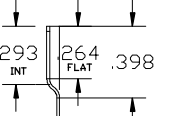
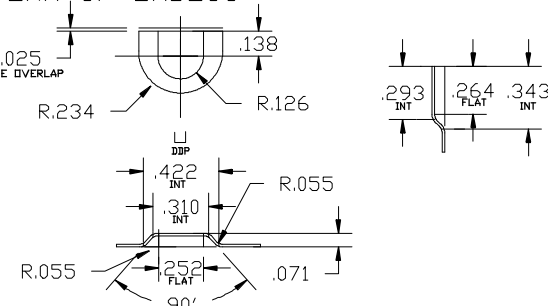
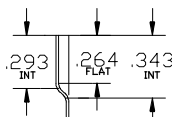
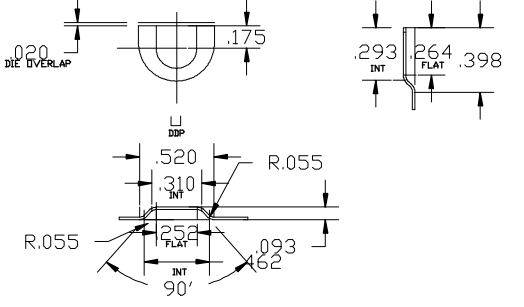
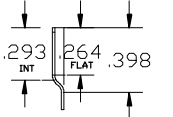
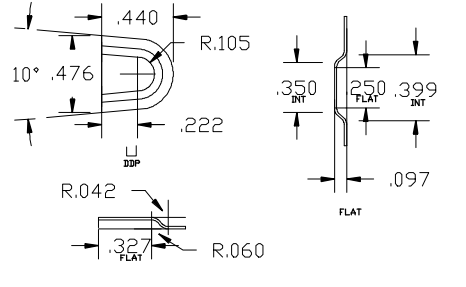
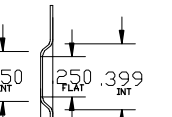
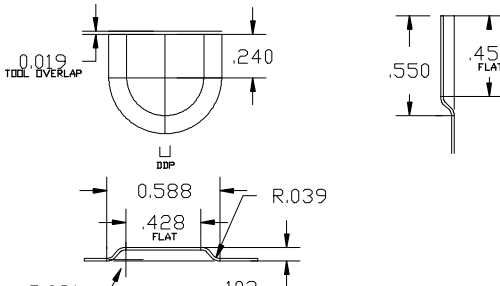
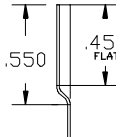
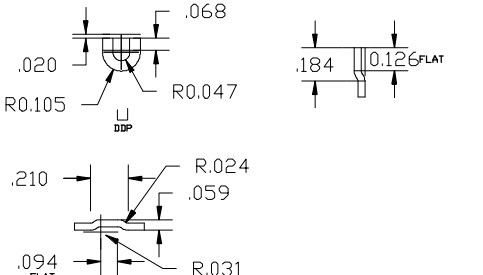
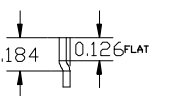

Dimples

TOOL #A10841201703	1/4 station	TOOL #A10841201978	1/4 station
<p>.015 CRS FORM UP EMBOSS</p> 		<p>.015 CRS FORM UP EMBOSS</p> 	
<p>TOOL #A10841201591</p> <p>.015 CRS FORM UP EMBOSS</p> 		<p>TOOL #A10841201702</p> <p>.015 CRS FORM UP EMBOSS</p> 	
<p>TOOL #A10841201592</p> <p>.015 CRS FORM UP EMBOSS</p> 		<p>TOOL #A10840801562</p> <p>.018 CRS FORM UP EMBOSS</p> 	
<p>TOOL #A10841201965</p> <p>.039 ALUM FORM UP EMBOSS</p> 		<p>TOOL #A10841201964</p> <p>.039 ALUM FORM UP EMBOSS</p> 	



H&S Manufacturing Co.

CONTRACT MANUFACTURING

Dimples

TOOL# A10841601967	$\frac{1}{4}$ STATION	TOOL# SP101413-08025	$\frac{1}{4}$ STATION
<p>.063 ALUM FORM UP OBOUND DIMPLE</p>		<p>.039 CRS FORM UP ROUND EMBOSS</p>	
TOOL# S101409-01352	$\frac{1}{4}$ STATION	TOOL# S107406-0265	$\frac{1}{4}$ STATION
<p>.025 STAINLESS STEEL FORM DOWN ROUND EMBOSS</p>		<p>.018 STAINLESS STEEL FORM DOWN ROUND DIMPLE</p>	
TOOL# A10841601934	$\frac{1}{4}$ STATION	TOOL# A10841201940	$\frac{1}{4}$ STATION
<p>.015 CRS FORM UP EMBOSS</p>		<p>.015 CRS FORM UP EMBOSS</p>	
TOOL# WT638206-10	$\frac{1}{4}$ STATION	TOOL#	$\frac{1}{4}$ STATION
<p>.020 COPPER FORM UP DIMPLE</p> <p>RUN THIS TOOL WITH .125 PEDESTAL TOOL # WT638206-20</p>		<p>.018 CRS FORM UP DIMPLE</p> <p>RUN THIS TOOL WITH .110 PEDESTAL TOOL # WT 646413-10</p>	



Dimples

TOOL # A10861002053	1/4 STATION	TOOL # A10841202081	1/4 STATION
<p>.063 ALUM</p>		<p>.015 CRS</p>	
TOOL # A3024080154	1/2 STATION	TOOL # A11441801337	1/4 STATION
<p>.016 SS</p>		<p>.015 CRS</p>	
TOOL # A10140102267	1/4 STATION	TOOL # A108412-02081	1/4 STATION
<p>.057 CRS</p>		<p>.015 CRS</p>	
TOOL #	1/4 STATION	TOOL #	1/4 STATION



Cluster Punches

SPT# 40514	TOOL# 02794	1 1/4 STAT.	SPT# CLUST156	TOOL# A5036010059	2 STAT.
PRT# CP02794	5502002 AIR BLOW	.012 CLR.	PRT# CP010059		.012 CLR.
SPT# CLUST188	TOOL# 09-0194	2 STAT.	SPT# 079CLUST	TOOL# 164272-10	1 1/4 STAT.
PRT# CP090194	REMOVEABLE PUNCHES	.012 CLR.	PRT#	REMOVEABLE PUNCHES	.010 CL.



Tab Tools

SPT# 038TAB	TOOL# 05552	1 1/4 STAT.	SPT# 41831	TOOL# 05-6490	1/2 STAT.
PRT# TT05552	.006 CLR.		PRT# TT056490	.008 CLR. .012 CLR	
SPT# TAB30	TOOL# SS04453	1 1/4 STAT.	SPT# WT 413986-10	TOOL# WT 413986-10	1 1/4 STAT.
			<p>NOTE: THESE ARE DIE DIMS PUNCH IS .004 SMALLER</p>		



H&S Manufacturing Co.

CONTRACT MANUFACTURING

Inner Keyway

SPT# IK00183	TOOL# 00183	1/2 STAT.	SPT# IK00184	TOOL# 00184	1/2 STAT.
PRT# IK00183	GUIDE KEYED 0 & 270 .010 CLR.		PRT# IK00184	GUIDE KEYED 0 & 90 .010 CLR. .018 & .024 CL	
SPT# IK058245	TOOL# 42246	1/2 STAT.	SPT# IK811576	TOOL# 48244	1/2 STAT.
PRT# IK42246	GUIDE KEYED 0 & 270 .012 CLR.		PRT# IK48244	GUIDE KEYED FOUR WAYS .010 CLR.	
SPT# IK803398	TOOL# 80-3398	1/2 STAT.	SPT# NONE	TOOL# WT846364	1/2 STAT.
PRT# IK803398	GUIDE KEYED FOUR WAYS .010 CLR. 2 PUNCHES & DIES AMADA & WILSON		PRT# IKW6364	GUIDE KEYED FOUR WAYS	
SPT#	TOOL# 271667-10	1/2 STAT.	SPT# IK09149	TOOL# 09149	1/2 STAT.
			PRT# 070035ik	GUIDE KEYED FOUR WAYS	



H&S Manufacturing Co.

CONTRACT MANUFACTURING

Connector Punches

SPT# CON2611A	TOOL# 42611A	1 1/4 STAT.	SPT# CON2611B	TOOL# 42611B	1 1/4 STAT.
PRT# CON2611A			PRT# CON2611B		
SPT# CON66366	TOOL# 766366	2 STAT.	SPT# CON65081	TOOL# 765081	1 1/4 STAT.
PRT# CON66366	DDP		PRT# CON65081	KEYED 4-WAYS .008 CLR.	
SPT# CON00907	TOOL# X00907	1 1/4 STAT.	SPT# CON02867	TOOL# 02867	1 1/4 STAT.
PRT# CON00907			PRT# CON02867	.010 CLR.	
SPT# CON27261	TOOL# WT827261	1 1/4 STAT.	SPT# con01675	TOOL# 01675	1 1/4 STAT.
PRT# CON27261	GUIDE KEYED 4-WAYS .020 CLR.		PRT#	DR #2166492 USE THIS	



H&S Manufacturing Co.

CONTRACT MANUFACTURING

Connector Punches

SPT# SX04266	TOOL# SX04266	1 1/4" STAT.	SPT# SX03636	TOOL# SX03636	1 1/4" STAT.
.008 CL.			KEYED 4-WAY .012 CL.		
SPT# SX03502	TOOL# SX03502	2" STAT.	SPT# SX03938	TOOL# SX03938	2" STAT.
KEYED 4-WAY .014 CL.			KEYED 4-WAY A/B .012 CL.		
SPT# SX03575	TOOL# SX03575	1 1/4" STAT.	SPT#	TOOL# 299437-30	1 1/4" STAT.
.008 CL.			.012 CL.		
SPT# CON00680	TOOL# WT405736-10	1 1/4" STAT.	SPT# CON00817	TOOL# S0422244-10	1 1/4" STAT.



H&S Manufacturing Co.

CONTRACT MANUFACTURING

Connector Punches

SPT#	TOOL#	1 1/4" STAT.	SPT#	TOOL#	1 1/4" STAT.
WT546576-20	WT546576-20	.012 CL.	SP01210	SP01210	.012 CL.
			KEYED 4-WAY A/B 		
SPT#	TOOL#	STAT.	SPT#	TOOL#	STAT.
SPT#	TOOL#	1 1/4" STAT.	SPT#	TOOL#	1 1/4" STAT.
SPT#	TOOL#	1 1/4" STAT.	SPT#	TOOL#	1 1/4" STAT.



H&S Manufacturing Co.

CONTRACT MANUFACTURING

Trapezoids

SPT# TRAP-D	TOOL# 03967	1/2 STAT.	SPT# TRAP4X19	TOOL# 096531	1/2 STAT.
PRT# TRP03967	2 PUNCHES & DIES .008 & .012 & .018 CLR. KEYED @ 0 & 90		PRT# TRP96531	2 PUNCHES & DIES .004, .008 & .012 & .018 CLR. GUIDE KEYED 4-WAYS	



H&S Manufacturing Co.

CONTRACT MANUFACTURING

Radius Tooling

SPT# RAD125-1	TOOL# 00780	1 1/4 STAT.	SPT# 060RAD-2	TOOL# 02724	1 1/4 STAT.
other tool#'s a554-0912/sx02687 .008,.012 CL			PRT# RT02724 .006 CLR.		
<p>A/B</p>					
SPT# 187RAD-1	TOOL# WT81-6148	1/2 STAT.	SPT# RAD062-4	TOOL# A401-0327	1/2 STAT.
.008,.012 CL			.010 CLR.		
<p>A/B</p>					
SPT# RAD093-4	TOOL# 01319	1 1/4 STAT.	SPT# RAD032-1	TOOL#08871	1 1/4 STAT.
.010,.015 CL			.012 CL		
SPT# 125RAD-4	TOOL# 401-0458	1 1/4 STAT.	.SPT# RAD187-4	t00l# 2037762	1 1/4 STAT
OTHER TOOL#'S A554-08384 .006,.010,.018 CL					
SX01180					
A554-0591					
<p>A/B</p>					



H&S Manufacturing Co.

CONTRACT MANUFACTURING

Radius Tooling

SPT# RAD250-4	TOOL# wt-01-1962	1 1/4 STAT.	SPT# ARC-6156	TOOL# 01760	1 1/4 STAT.
PRT# RT250-4	ALSD WT#201488-100	.010 & .018 CL.	PRT# RT6156		.006 CLR.
SPT# AR10X118	TOOL# 01166	1 1/4 STAT.	SPT# AR187X70	TOOL# WT037166	1 1/4 STAT.
PRT# RTAR1000		.006 CLR	PRT# RTARC187		.006 CLR.
+			□ DDP		
SPT# AR25x375	TOOL# WT03-1676	1 1/4 STAT.	SPT# AR38X63	TOOL# A01167	1 1/4 STAT.
PRT# RTARC250		.018 CLR.	PRT# RTARC380		.006 CLR. .018 CLR
			□ DDP GUIDE KEYS		
SPT# 062RAD-1	TOOL# wt 825631	1/2 STAT.	SPT# RAD094-1	TOOL# wt 853940	1 1/4 STAT.
DDP @ 0' FDR MINI TURRET		A/B	.012 clr		
□ DDP			□ DDP		



H&S Manufacturing Co.

CONTRACT MANUFACTURING

Radius Tooling

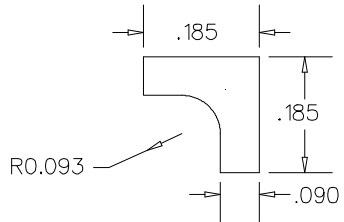
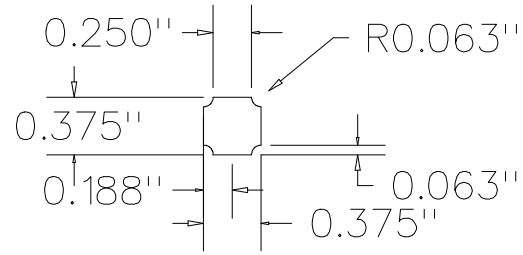
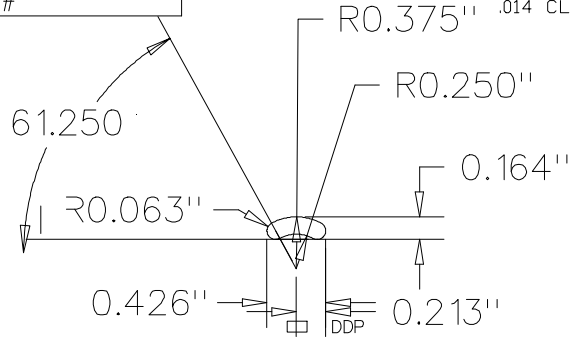
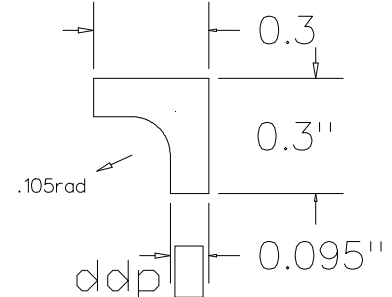
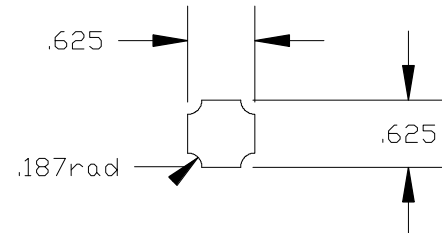
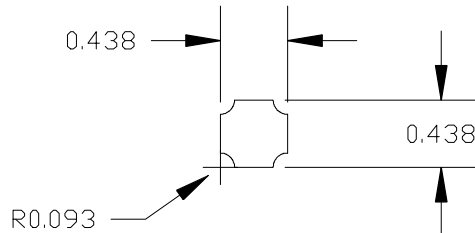
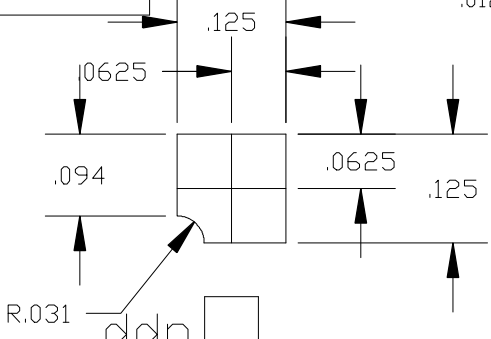
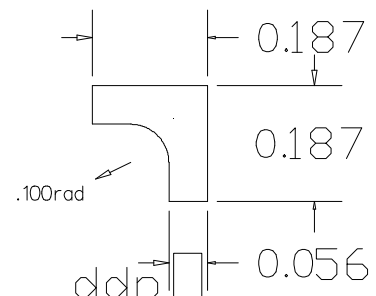
.SPT# RAD093-1	TOOL# 08579	1/2 STAT.	.SPT# 062RAD-4	TOOL# A554-0644	1 1/4 STAT
 <p>DDP</p>			<p>OTHER TOOL#'S SX02681 / A554-0913</p> <p>A/B</p> 		
.SPT# 2AR25X375	TOOL# SX00881	1 1/4 STAT	.SPT# 105RAD-1	TOOL# 09145	1/2 STAT
<p>PRT#</p> <p>A/B</p>  <p>DDP</p>	<p>.014 CL</p>		<p>A/B</p>  <p>ddp</p>	<p>.008 CL</p>	
.SPT# 187rad-4	TOOL# A554-0914	1 1/4 STAT	.SPT# 093RAD-4	TOOL# A554-0643	1 1/4 STAT
<p>PRT#rad</p> <p>A/B</p> 	<p>.008, .012 CL</p>		<p>OTHER TOOL# A554-0914</p> <p>A/B</p> 		
.SPT# 2152484	TOOL# RAD032X1	1 1/4 STAT	.SPT# 100rad-1	TOOL# SX02919	1/2 STAT
<p>PRT#</p> <p>A/B</p>  <p>ddp</p>	<p>.012 CLR</p>		<p>100RAD-1X = 1/2" STATION</p> <p>A/B</p>  <p>ddp</p>		

2913 SINGLETON - P.O. BOX 1515 - ROWLETT, TEXAS 75030-1515

Phone (972) 475-4747 - FAX (972) 475-6155

website: www.hsmfg.com



Radius Tooling

SPT# 050RAD-1	TOOL# sx02920	1/2 STAT.	.SPT# 020rad-1	TOOL# 2095190	1 1/4 STAT
.SPT# ss04528	TOOL# ss04528	1 1/4 STAT	.SPT# 156rad-4	TOOL# SX02986	1 1/4 STAT
.SPT# 2120526	tool# w.t. 2120526	1 1/4 STAT	.SPT# 203rad-1	TOOL# sx03450	1 1/4 STAT
.SPT# 2115594	TOOL# w.t. 2115594	1 1/4 STAT	.SPT# 2115595	TOOL# w.t. 2115595	1 1/4 STAT

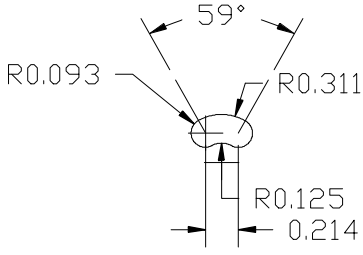
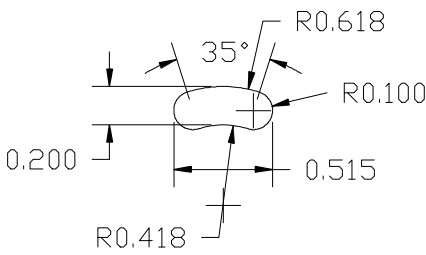
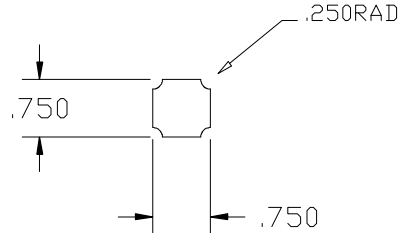
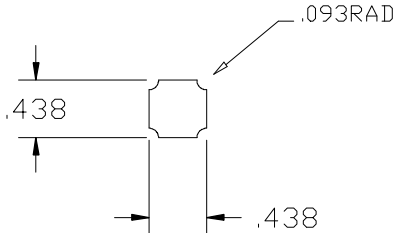
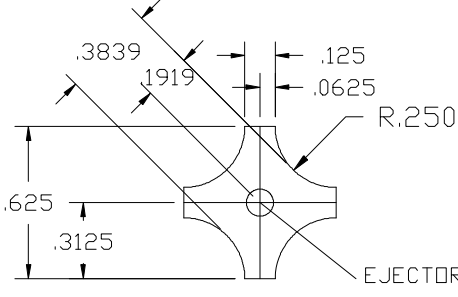
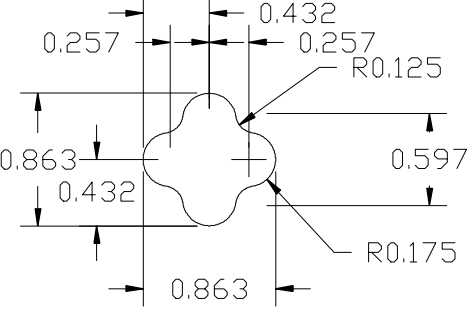
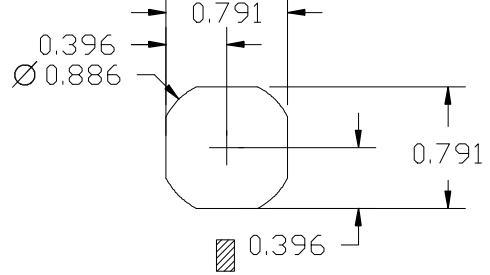
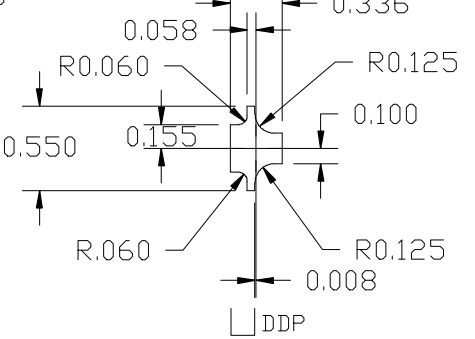

Radius Tooling

.SPT# BANRAD2	TOOL# 2164824	1 1/4 STAT.	.SPT# WT617989-10	TOOL# WT617989-10	1 1/4 STAT
<p>A/B</p> 			<p>A/B</p> 		
.SPT# 250RAD-4	TOOL# SA0033	1 1/4 STAT	.SPT# 093rad-4	TOOL# A554-0643	1 1/4 STAT
<p>.006,.008,.010,.012,.024 CL.</p> <p>A/B</p> 			<p>A/B</p> 		
.SPT#SX04496	t00l# SX04496	1 1/4 STAT	.SPT# sp125rad	TOOL# 5504060	1 1/4 STAT
<p>A/B</p> <p>.012 CL.</p> 			<p>A/B</p> <p>.008CLR</p> 		
.SPT# SX02685	TOOL# SX02685	1 1/4 STAT	.SPT# SS02002	TOOL# SS02002	1 1/4 STAT
<p>A/B</p> <p>.012 CL.</p> 			<p>A/B</p> 		



H&S Manufacturing Co.

CONTRACT MANUFACTURING

Radius Tooling

SPT# SX03005	TOOL# SX03005	1 1/4" STAT.	SPT#BAN2451785	TOOL# 2451785	1 1/4" STAT.
<p>A/B</p>			<p>A/B</p>		
SPT# 5720RAD	TOOL#2466885	1 1/4" STAT.	SPT# 500BANRAD	TOOL# 139784-10	1 1/4" STAT.
			<p>.012 CL</p>		
SPT# 217RAD-4	TOOL# WT141380-10	1 1/4" STAT.	SPT# 173519	TOOL#WT 173519-10	1 1/4" STAT.
<p>A/B</p> <p>.012 CL</p>			<p>KEYED 4-WAY</p> <p>FDR P/N A6868-00042 B</p>		
SPT# 080RAD-4	TOOL#WT 196620-70	1 1/4" STAT.	SPT#WT 196620-30	TOOL# 3800RAD	1 1/4" STAT.
<p>.012 CL</p>			<p>A/B</p> <p>.012 CL</p>		



Radius Tooling

<p>SPT# RAD039-1 KEY @ 270' RAD039-1M FOR MINI TURRET, KEY @ 0'</p> <p>A.B.S.</p> <p>DDP U</p>	<p>TOOL# WT320506-10 1/2" STAT. .012 CL</p>	<p>SPT# RAD039X-1</p> <p>A.B.S.</p> <p>DDP U</p>	<p>TOOL# WT318460-10 1/2" STAT. .012 CL</p>
<p>SPT# 079RAD</p> <p>DDP U</p>	<p>TOOL# WT303625-20 1 1/4" STAT. .012 CL</p>	<p>SPT# RAD060-1</p> <p>A.B.S.</p> <p>DDP U</p>	<p>TOOL# WT312622-10 1/2" STAT. .012 CL</p>
<p>SPT# 322197-10</p> <p>FOR 1 1/4" STA. KEY @ 270' FOR MINI TURRET, KEY @ 0'</p> <p>A.B.S.</p> <p>DDP U</p>	<p>TOOL# WT322197-10 1/2" STAT. .012 CL</p>	<p>SPT# 323406-10</p> <p>A.B.S.</p> <p>DDP U</p>	<p>TOOL# WT323406-10 1 1/4" STAT. .012 CL</p>
<p>SPT#</p> <p>A.B.S.</p> <p>DDP U</p>	<p>TOOL# WT323340-10 1/2" STAT. .012 CL</p>	<p>SPT#</p> <p>DDP U</p>	<p>TOOL# WT403739-10 1 1/4" STAT. .008, & .012 CL</p>



H&S Manufacturing Co.

CONTRACT MANUFACTURING

Radius Tooling

SPT#	TOOL# WT155024-10	1 1/4" STAT.	SPT#	TOOL# WT173538-50	1 1/4" STAT.
THIS IS A NAT'L INST. TOOL THEY GAVE TO US FROM ANOTHER CO.		.006 CL	THIS IS A NAT'L INST. TOOL THEY GAVE TO US FROM ANOTHER CO.		.012 CL
SPT#	TOOL# SS09401	4 1/2" STAT.	SPT#	TOOL# WT2466885	1 1/4" STAT.
		.020 CL	THIS IS A H&S TOOL SAME AS ABOVE		.012 CL
SPT#	TOOL# SS09400	4 1/2" STAT.	SPT#	TOOL# WT399790-10	1 1/4" STAT.
		.020 CL			.004 CL
SPT#	TOOL# WT436078-10	1/2" STAT.	SPT#	TOOL# SP0362	1 1/4" STAT.
FOR 018-0102-003 P1		.012 CL A.B.S.			.012 CL A.B.S.

2913 SINGLETON - P.O. BOX 1515 - ROWLETT, TEXAS 75030-1515

Phone (972) 475-4747 - FAX (972) 475-6155

website: www.hsmfg.com



H&S Manufacturing Co.

CONTRACT MANUFACTURING

Radius Tooling

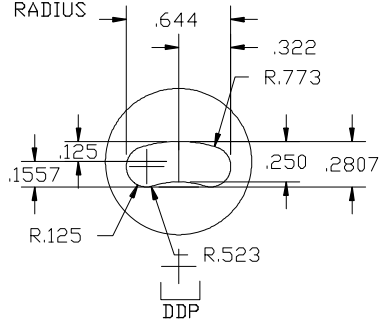
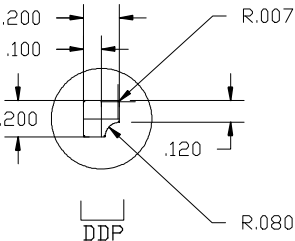
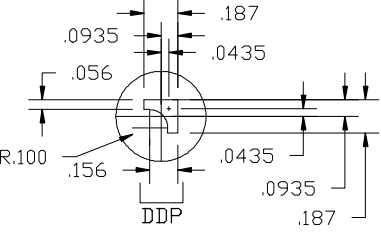
TOOL # WT617989-10	1 ¼ STATION	TOOL # WT617989-10	½ STATION
<p>.090 ALUM .523 BANANA RADIUS</p> 		<p>.072 CRS .080 RADIUS</p> 	
TOOL # SX02919	½ STATION		
<p>.100 RADIUS</p> 			



Special Shapes

SPT# SS-02331		TOOL# 02331		1 1/4 STAT.	
PRT# SS02331				.008 CLR.	
SPT# M-RAD640		TOOL# 02351		1 1/4 STAT.	
PRT# SS02351				.008 CLR.	
SPT# SS-02516		TOOL# 02516		1 1/4 STAT.	
PRT# SS02516				BLANKING TOOL .006 CLR	
SPT# SS-02517		TOOL# 02517		1 1/4 STAT.	
PRT# SS02517		PART # 704A\$11172		BLANKING TOOL .006 CLR.	
SPT# SS2-5504		TOOL# WT02-5504		2 STAT.	
PRT# SS025504				BLANKING TOOL .004 CLR.	



H&S Manufacturing Co.

CONTRACT MANUFACTURING

Special Shapes

SPT# SS-02726	TOOL# A02726	2 STAT.	SPT# 38485	TOOL# 03-1941	3 1/2 STAT.
PRT# SS02726	PART # 898644-1 BLANKING TOOL .006 CLR.		PRT# SS031941	PART # 417U1217-1201 BLANKING TOOL .006 CLR.	
SPT# 38245	TOOL# 03-5538	3 1/2 STAT.	SPT# AL1738HC	TOOL# 04041	2 STAT.
PRT# SS035538	BLANKING TOOL PART # 417U5136-8 .005 CLR		PRT# SS04041	BLANKING TOOL .020 CLR.	
SPT# SS-40994	TOOL# 05-2431	1/2 STAT.	SPT# 1650871	TOOL# 35611T	3 1/2 STAT.
PRT# SS052431	BLANKING TOOL PART # 546-7111-003 7112 .004 CLR.		PRT# SS35611	PART # 1650871-1 BLANKING TOOL .010 CLR.	
SPT# SS-0953	TOOL# 00-0953	3 1/2 STAT.	SPT# SS-0954	TOOL# 00-0954	2 STAT.
PRT# SS000953	BLANKING TOOL .006 CLR.		PRT# SS000954	BLANKING TOOL .006 CLR.	

2913 SINGLETON - P.O. BOX 1515 - ROWLETT, TEXAS 75030-1515

Phone (972) 475-4747 - FAX (972) 475-6155

website: www.hsmfg.com



Special Shapes

SPT# 01991		TOOL# 021-102881			
SPT# 01990					
PRT# SS102881					
<p>SPT# 01990</p> <p>SPT# 01991</p>					
SPT# 01990	TOOL# 021-102881	1 1/4 STAT.	SPT# 01991	TOOL# 021-102881	1/2 STAT.
PRT#	BLANKING TOOL .006 CLR.			PRT#	.006 CLR.
<p>GUIDE KEYS</p> <p>DDP</p>			<p>GUIDE KEYS</p> <p>DDP</p>		
SPT# SS-00722	TOOL# 00722	1 1/4 STAT.	SPT# SS-02610	TOOL# 02610	1 1/4 STAT.
PRT# SS00722	PART # 2796823-1 BLANKING TOOL .015 CLR.			PRT# SS02610	BLANKING TOOL .008 CLR.
<p>GUIDE KEYS</p> <p>DDP</p>			<p>DIE KEYWAY</p>		



H&S Manufacturing Co.

CONTRACT MANUFACTURING

Special Shapes

SPT# SS4-0023		TOOL# 04-0023		3 1/2 STAT.		
PRT# SS4-0023						.008 CLR.
SPT# ELLIPSE	TOOL# WT036885	2 STAT.	SPT# SS039840	TOOL# 03-9840	3 1/2 STAT.	
PRT# SS036885	ELLIPSE .004 CLR.		PRT# SS039840	BLANKING TOOL .006 CLR		
SPT# 41505	TOOL# 05-2171	1 1/4 STAT.	SPT# BL237R06	TOOL# 054435	3 1/2 STAT	
PRT# SS052171	PART # 695-5161-001 .012 CLR.		PRT# SS054435	PART # 695-6279-001 & 002 BLANKING TOOL .005 CLR.		



H&S Manufacturing Co.

CONTRACT MANUFACTURING

Special Shapes

SPT# SS-41322	TOOL# 41322	4 1/2 STAT.	SPT# 416610	TOOL# 416610	1/2 STAT.
PRT# SS41322	PART # 330-000224-500 .020 CLR.		PRT# SS416610	KEYED 4-WAY .012 CLR.	
SPT# 41661S	TOOL# 41661S	1/2 STAT.	SPT# 44282	TOOL# 44282	2 STAT.
PRT# SS41661S	KEYED 4-WAY .012 CLR.		PRT# SS44282	PART # 2830786-1 BLANKING TOOL .016 CLR.	
SPT# 38969	TOOL# A02249	1 1/4 STAT.	SPT# SS010569	TOOL# SS010569	1 1/4 STAT.
PRT# SSA02249	.010 CLR.		PRT#	.008, .012, .018 CL	
SPT# NONE	TOOL# A08747	1 1/4 STAT.	SPT# 508992-10	TOOL# 508992-10	1/2 STAT.
PRT# SSA08747	.010 CLR.		PRT#	.018 CL	
			FOR P/N 139-00-275-01 04 		



Special Shapes

SPT#	TOOL# WT2060198	1 1/4 STAT.	SPT#	TOOL# TLX02643	1 1/4 STAT.
PRT#			PRT#		.375 HALF HEX
SPT#	TOOL#	1 1/4 STAT.	SPT# 513088-30	TOOL# 513088-30	2" STAT.
PRT#		.250 HALF HEX	DIMENSIONS ARE ACTUAL DIE SIZE BLANKING TOOL		.012 CL
SPT# SX03469	TOOL# SX03469	4 1/2 STAT.	SPT# SX03201	TOOL# SX03201	1 1/4 STAT.
PRT#			DIMENSIONS ARE ACTUAL DIE SIZE BLANKING TOOL		
SPT# SS03597	TOOL# SS03597	2 STAT.	SPT# 2096322	TOOL# 2096322	1 1/4 STAT.
DIMENSIONS ARE ACTUAL DIE SIZE BLANKING TOOL			A/B DIMENSIONS ARE ACTUAL DIE SIZE BLANKING TOOL		



Special Shapes

SPT# SS04381	TOOL# SS04381	1 1/4 STAT.	SPT# SS04382	TOOL# SS04382	STAT.
PUNCHES PART# 3AG17744AAAA 01 			PUNCHES PART# 3AG17744AAAA 01 		
SPT# ss04137	TOOL# ss04137	2" STAT.	SPT# 2127900	TOOL# 2127900	2" STAT.
A/B KEYED @ 0° x 270° 			A/B KEYED @ 0° & 180° 		
SPT# SS04709	TOOL# SS04709	1 1/4" STAT.	SPT# SX03623	TOOL# SX03623	1/2" STAT.



Special Shapes

SPT# SX03624	TOOL# SX03624	1 1/4" STAT.	SPT# SS05277	TOOL# SS05277	2" STAT.
<p>A/B</p>			<p>BLANK OUT TOOL .009CLR</p>		
SPT# 415US	TOOL# WT2152482	1 1/4" STAT.	SPT# 2152483	TOOL# 2152483	1/2" STAT.
<p>A/B</p>			<p>A/B .012 CL.</p>		
SPT# SX04609	TOOL# SX04609	1 1/4" STAT.	SPT# 2525BLK	TOOL# 2136011	3 1/2" STAT.
<p>BLANK-OUT TOOL .012 CL.</p>			<p>BLANK-OUT TOOL .012 CL.</p>		
SPT# 2550BLK	TOOL# 2136010	3 1/2" STAT.	SPT# 210RAD	TOOL# 2145239	1 1/4" STAT.
<p>BLANK-OUT TOOL .012 CL.</p>			<p>.008 CL.</p>		



H&S Manufacturing Co.

CONTRACT MANUFACTURING

Special Shapes

SPT# XUC36AP	TOOL# 2149316	1 1/4" STAT.	SPT# 2145438	TOOL# 2145438	1/2" STAT.
		.012 CL.			
SPT# 2145439	TOOL# 2145439	1 1/4" STAT.	SPT# 2134759	TOOL# 2134759	1 1/4" STAT.
		.012 CL.			
SPT# SX03581	TOOL# SX03581	1 1/4" STAT.	SPT# SS05181	TOOL# SS05181	1 1/4" STAT.
		.008 CL.			
SPT#	TOOL# SX03628	1 1/4" STAT.	SPT# 181876-10	TOOL# 181876-10	2" STAT.
		.012 CLR	<p>BLANK-OUT TOOL FOR RECARD 139-00-410-14 001</p>		



H&S Manufacturing Co.

CONTRACT MANUFACTURING

Special Shapes

SPT#	TOOL#	STAT.	SPT#	TOOL#	SS04774	2" STAT.
			KEYED 4 WAYS OLD# FOR USE ON P/N A5210-00000 A NEW# FOR USE ON P/N A9782-00001 X4			
SPT# SS05438	TOOL# SS05438	2" STAT.				
OLD# FOR USE ON P/N A5210-00000 A NEW# FOR USE ON P/N A9782-00001 X4						
DDP						
SPT#	WT280410-10	TOOL#	WT280410-10	1 1/4 STAT.		
FOR 460-005-899 A				.005 CL A.B.S.		



H&S Manufacturing Co.

CONTRACT MANUFACTURING

Special Shapes

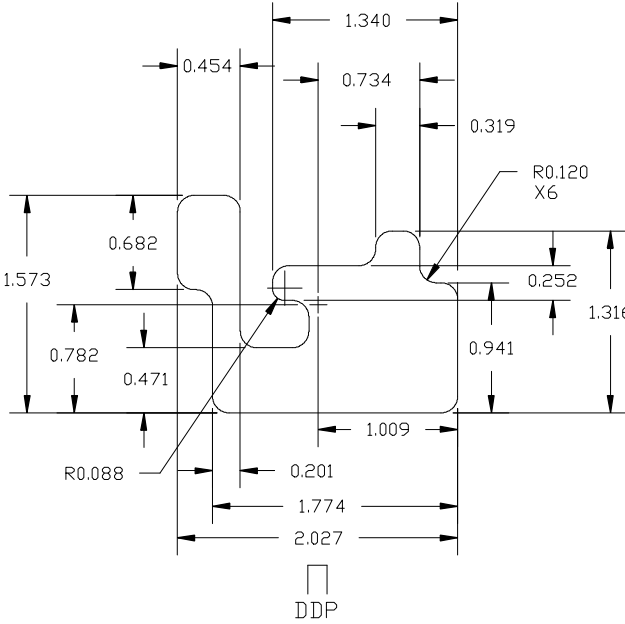
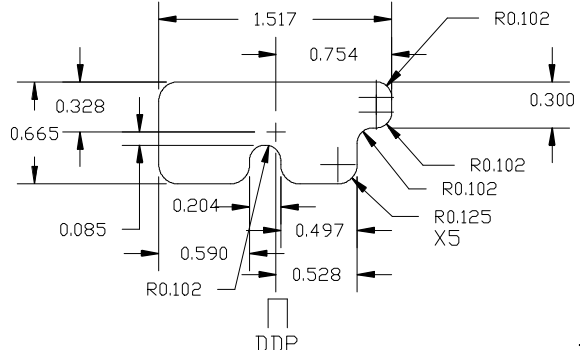
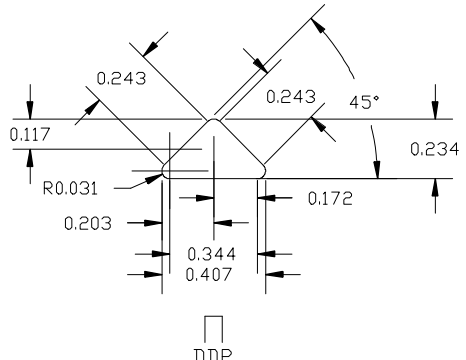
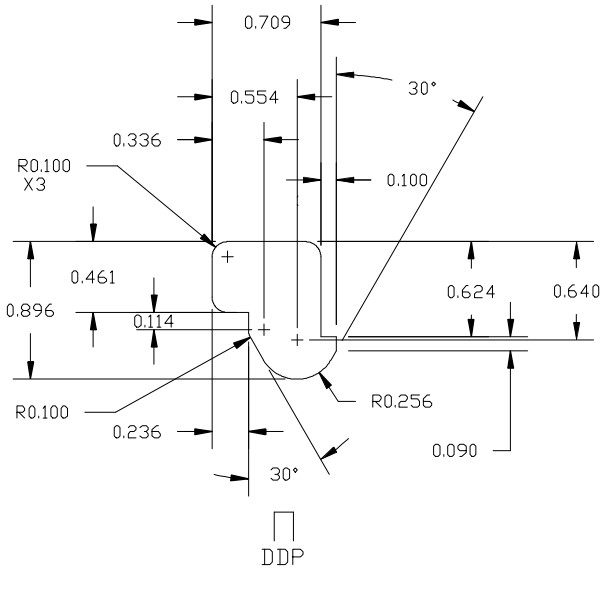
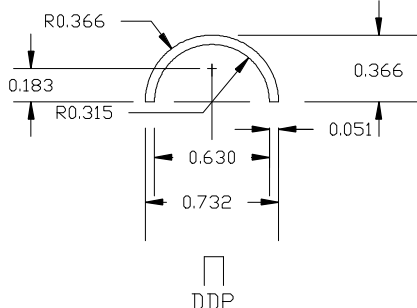
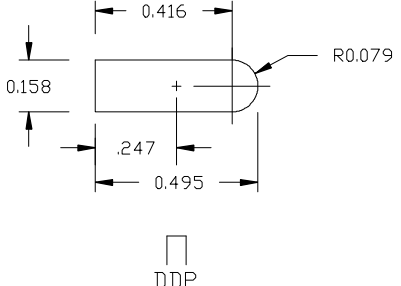
SPT# 2254770	TOOL# 2254770	3 1/2" STAT.	SPT# 2254769	TOOL# 2254769	2" STAT.
<p>FOR P/N 967-1645-001 REV B .050 6061-T6 ALUM</p> <p>DIMS ARE DIE SIZE, PUNCH IS .010 SMALLER</p> 			<p>FOR P/N 967-1645-002 REV B .050 6061-T6 ALUM</p> <p>DIMS ARE DIE SIZE, PUNCH IS .010 SMALLER</p> 		
<p>SPT# 317453-120</p> <p>TOOL# WT317453-120</p> <p>1 1/4" STAT.</p> <p>A.B.S. .012 CL</p> 			<p>SPT# WT2516367</p> <p>TOOL# WT2516367</p> <p>1 1/4" STAT.</p> <p>FOR P/N A5861-00042 REV B .089 CRS</p> <p>DIMS ARE DIE SIZE, PUNCH IS .014 SMALLER</p> 		
<p>SPT# 318035-10</p> <p>TOOL# WT318035-10</p> <p>1 1/4" STAT.</p> <p>A.B.S. .012 CL</p> 			<p>SPT# 1575X4955LD</p> <p>TOOL# N/A</p> <p>1 1/4" STAT.</p> <p>A.B.S. .012 CL</p> 		



H&S Manufacturing Co.

CONTRACT MANUFACTURING

Special Shapes

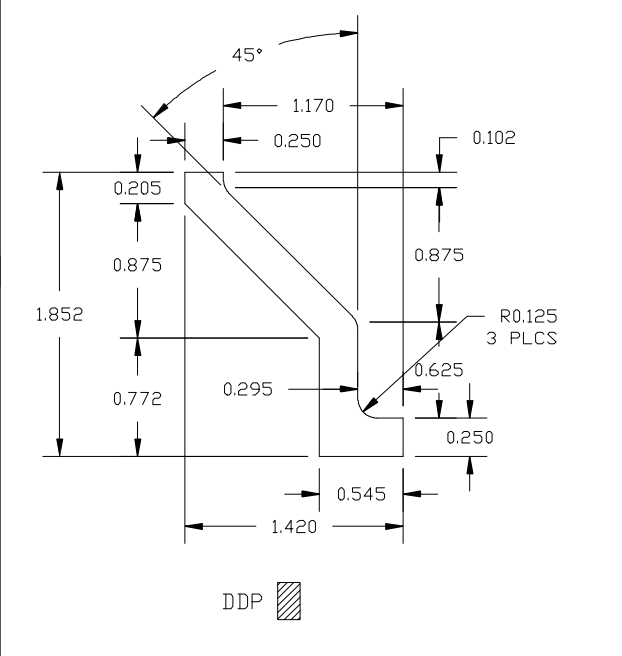
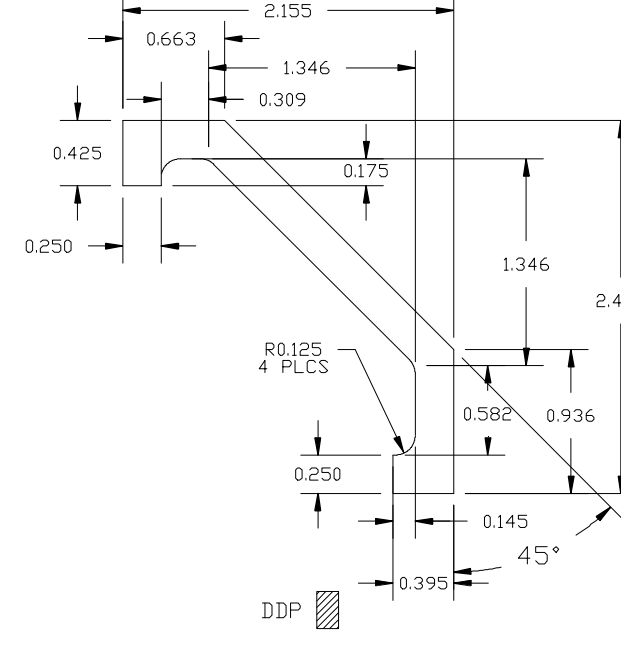
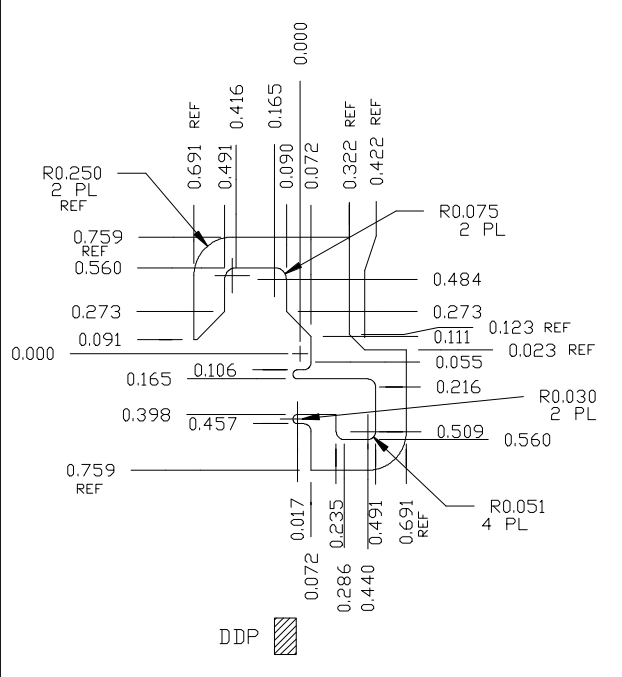
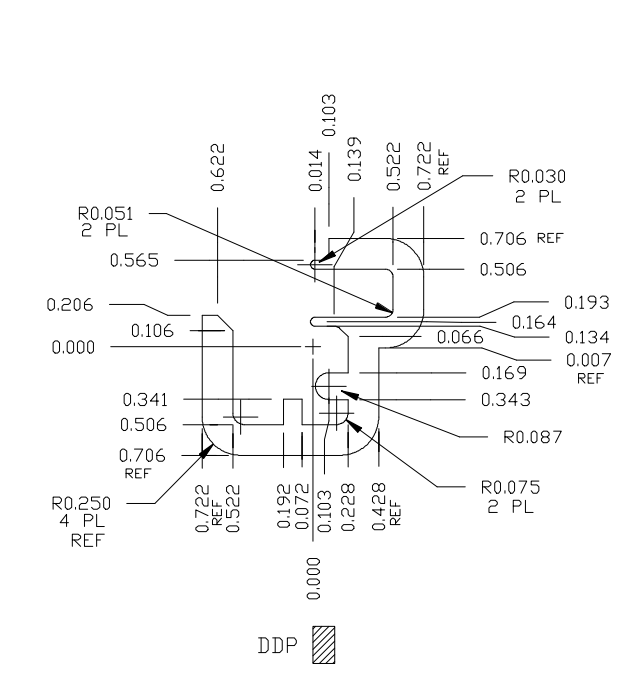
SPT# SS03971	TOOL# SS03971	3 1/2 STAT.	SPT# SS03972	TOOL# SS03972	3 1/2 STAT.
PRT#			PRT#		
PUNCHES PART# 3AG17723AAAA & ABAA			PUNCHES PART# 3AG17723AAAA & ABAA		
					
SPT# SS07319	TOOL# SS07319	2" STAT.	SPT# SS07320	TOOL# SEE BELOW	2" STAT.
PRT#	.006 CL.		PRT#	PUNCH BODY #4553 DIE #SS07320 .006 CL.	
FOR P/N A9784-00001 B			FOR P/N A9784-00001 B		
					



H&S Manufacturing Co.

CONTRACT MANUFACTURING

Special Shapes

TOOL# .218 X .170 SINGLE D FOR 3EM21496AAAA 01		1/2" STAT.	SPT#	TOOL# A1184140492	1 1/4" STAT.
				USE M568 DEBURR TOOL	
TOOL# .420 X .367 SINGLE D FOR 3EM21496AAAA 01		1 1/4" STAT.			
SPT#	TOOL# 333859-10	1 1/4" STAT.	SPT#	TOOL# 331201-20	1 1/4" STAT.
			FOR A6866-00044 A AND A6866-00046 A		.012 CL A.B.S.
ALSO HAVE MIRROR IMAGE TL#324814-50					
SPT#	TOOL# 331201-10	1 1/4" STAT.	SPT#	TOOL# 331201-30	1 1/4" STAT.
FOR A6866-00044 A AND A6866-00046 A		.012 CL A.B.S.	FOR A6866-00044 A AND A6866-00046 A		.012 CL A.B.S.

2913 SINGLETON - P.O. BOX 1515 - ROWLETT, TEXAS 75030-1515

Phone (972) 475-4747 - FAX (972) 475-6155

website: www.hsmfg.com



H&S Manufacturing Co.

CONTRACT MANUFACTURING

Special Shapes

SPT# 324818-10	TOOL# WT324818-10	1 1/4" STAT.	SPT# SX09077	TOOL#	4 1/5" STAT.
FDR A4856-00031 B		.012 CL	FDR A4856-00031 B		.012 CL
FDR A6866-00019 C		.012 CL A.B.S.	FDR A5201-00378 B		.012 CL
FDR A5861-00009 C		.012 CL	FDR A5861-00009 C		.012 CL
FDR A6866-00060 B		.012 CL	FDR 3EM00830AAAA		.008 CL A.B.S.



Special Shapes

SPT#	SS08281	TOOL#	SS08281	2" STAT.	SPT#	SS08282	TOOL#	SS08282	2" STAT.
<p>GOOD FOR BOTTOM AB465-00001 A AB290-00001 A A9784-00001 C .008 CL</p>					<p>GOOD FOR TOP A9784-00001 C AB465-00001 A A9782-00001 B .008 CL</p>				
<p>SPT# SS08328 GOOD FOR BOTTOM A9782-00001 B .008 CL</p>					<p>SPT# SS08329 GOOD FOR TOP AB290-00001 A .008 CL</p>				



Special Shapes

<p>SPT# SS08882 FOR A5210-00002 A</p>	<p>TOOL# SS08882</p>	<p>2" STAT. .008 CL</p>	<p>SPT# SS08881 FOR A5210-00002 A</p>	<p>TOOL# SS08881</p>	<p>2" STAT. .008 CL</p>
<p>SPT#</p>	<p>TOOL#</p>	<p>2" STAT.</p>	<p>SPT# WT540858-10</p>	<p>TOOL# WT540858-10</p>	<p>1 1/4" STAT.</p>
<p>BLANK-OUT TOOL FOR 32.1555.958-25 AB</p>		<p>BLANK-OUT TOOL FOR 1675991-2 B</p>			
<p>SPT# WT546576-10</p>	<p>TOOL# WT546576-10</p>	<p>1 1/4" STAT.</p>	<p>SPT# N/A</p>	<p>TOOL# N/A</p>	<p>1 1/4" STAT.</p>
<p>FOR 54-00231-51R B</p>		<p>.156 X .625 OBROND KEYED @ 125'</p>			



Special Shapes

TOOL # SS011699	2 STATION	TOOL # SX011445	½ STATION
TOOL # SS011870	1¼ STATION	TOOL # WT617357-60	1¼ STATION
TOOL # SS011796	½ STATION	TOOL # SS011869	1¼ STATION
TOOL # SS011871	1¼ STATION	TOOL # SS015266	1¼ STATION

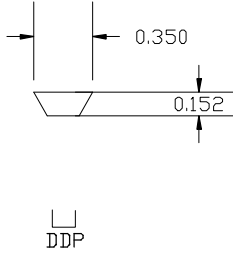
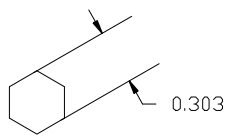

Special Shapes

TOOL # 943871-10	1/2 STATION	TOOL # 943531-10	1/2 STATION
HALF HEX TOOL 		.303 HEX TOOL 	



H&S Manufacturing Co.

CONTRACT MANUFACTURING

Counter Bores

SPT# NONE PRT# CB000355	TOOL# A100-0355 FORM UP	1 1/4 STAT.	SPT# NONE PRT# CB000482	TOOL# A100-0482 .225 DIA. TOP CHIP FORM UP	1 1/4 STAT.
SPT# NONE PRT# CB000932	TOOL# WT-2616 FORM DOWN TOP CHIP	1 1/4 STAT.	SPT# NONE PRT# CB010824	TOOL# A1004010824 F/D TOP CHIP PREPUNCH .163 .074 THK.	1 1/4 STAT.
SPT# NONE PRT# CB040211	TOOL# A553204-0211 FORM DOWN	1/2 STAT.	SPT# NONE PRT# CB040212	TOOL# A553204-0212 FORM DOWN	1 1/4 STAT.
SPT# NONE PRT# CB056301	TOOL# WT05-6301 FORM DOWN	1 1/4 STAT.	SPT# NONE PRT# CB058251	TOOL# WT05-8251 FORM DOWN	1 1/4 STAT.



H&S Manufacturing Co.

CONTRACT MANUFACTURING

Counter Bores

SPT# NONE	TOOL# A100-410	1 1/4 STAT.	SPT# NONE	TOOL# 1519-576	2 STAT.
PRT# CB100410	FORM UP		PRT# CB151957	PREPUNCH, CBORE & POST PUNCH PRE & POST PUNCH WITH SAME PUNCH FORM DOWN	
SPT# NONE	TOOL# 2006-86	1 1/4 STAT.	SPT# NONE	TOOL# 43785	1 1/4 STAT.
PRT# CB200686	FORM DOWN		PRT# CB43785	FORM DOWN	
SPT# NONE	TOOL# A5532040211	1/2 STAT.	SPT# NONE	TOOL# TDT450CBORE	1/2 STAT.
PRT# CB553204	PRE-HOLED REQ'D		PRT# CBTDT450	FORM DOWN	
			<p>.450 DIA. PUNCH GROUND SHORT</p>		
SPT# NONE	TOOL# TDT575CBORE	1 1/4 STAT.	SPT# NONE	TOOL# A100430-0876	1 1/4 STAT.
PRT# CBTDT575	.575 GROUND DOWN FORM DOWN		PRT# CB300876	FORM DOWN	



Counter Bores

SPT# NONE	TOOL# WT6301	1 1/4 STAT.	SPT# NONE	TOOL# 0494	1 1/4 STAT.
PRT# CBWT630	FORM DOWN		PRT# CB0494	FORM DOWN	
SPT# NONE	TOOL# WT85-7951	1 1/4 STAT.	SPT# NONE	TOOL# 0768	1 1/4 STAT.
PRT# CB57951	FORM DOWN		FORM DOWN		
			<p>W/PILOT</p>		
SPT# NONE	T#WT0494	1 1/4 STAT.	SPT# NONE	T#A553420-0423	1 1/4 STAT.
FORM DOWN			FORM DOWN		
<p>W/PILOT</p>					
T#6301&9792		1 1/4 STAT.	<p>.221 C-BORE 1/2 STAT TDT</p> <p>.500 C-BORE 1/2 STAT TDT</p> <p>.336 C-BORE 1/2 STAT TDT</p> <p>.340 C-BORE 1/2 STAT TDT</p> <p>.187 C-BORE 1/2 STAT TDT</p> <p>.434 C-BORE 1/2 STAT TDT</p> <p>.312 C-BORE 1/2 STAT TDT</p>		
FORM DOWN					
<p>W/PILOT</p>					



Counter Bores

SPT# 2064210	TOOL# WT2064210	1 1/4 STAT.	SPT#	TOOL#	STAT.
FORM DOWN .063 THK			PRT#		