

ifm electronic



Installation instructions
Vibration sensor

efector800[®]

VSA001

UK

704105/06 08/2015

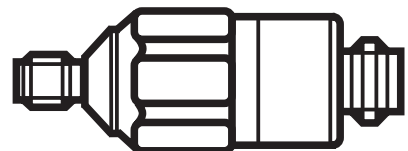

Contents

1 Preliminary note.....	3
2 Safety instructions	3
3 Functions and features	3
4 Electrical connection.....	3
4.1 Use of a screened cable	4
5 Installation.....	4
5.1 Making a conical bore hole	5
6 Scale drawing	6
7 Maintenance, repair and disposal.....	6
8 Technical data.....	6

1 Preliminary note

- An instruction is indicated by „▶“:
Example: ▶ Mount the unit as shown.



Important note

Non-compliance can result in malfunction or interference.



Information

Supplementary note.

2 Safety instructions

UK

- Please read the operating instructions prior to set-up of the device. Ensure that the product is suitable for your application without any restrictions.
- The unit conforms to the relevant regulations and EC directives.
- Improper or non-intended use may lead to malfunctions of the unit or to unwanted effects in your application.
- Installation, electrical connection, set-up, operation and maintenance of the unit must only be carried out by qualified personnel authorised by the machine operator.

3 Functions and features

- Vibration detection of machines and equipment
- For connection to diagnostic electronics VSExxx

4 Electrical connection



The unit must be connected by a qualified electrician.

The national and international regulations for the installation of electrical equipment must be adhered to.

- ▶ Disconnect power.
- ▶ Connect the unit.

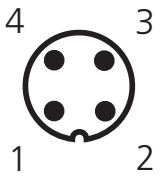
M12		Pin 1: L+ (7.2...10.8 V DC)
		Pin 2: I _{out}
		Pin 3: GND
		Pin 4: self-test

4.1 Use of a screened cable

- ▶ Use a screened cable to avoid conducted interference.
- ▶ Connect the screened cable to the DIN rail in the control cabinet.

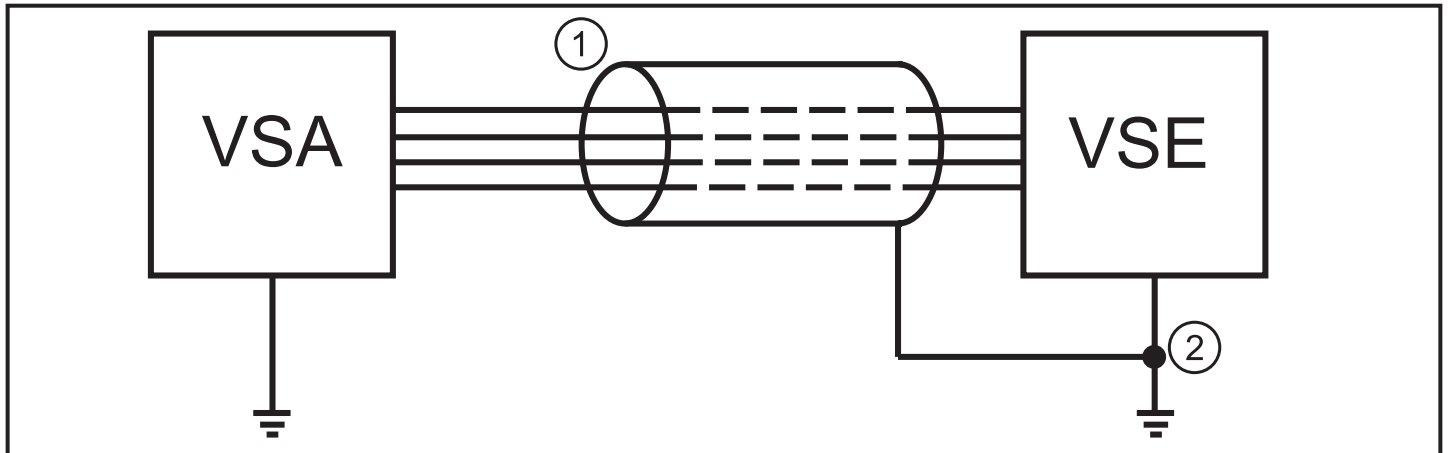

- 1: screen
- 2: DIN rail

5 Installation

- ▶ Mount only in a thick housing wall and vertical to the machine surface close to the bearing or at the end shield.
- ▶ Ensure that the signal direction is correct.
- ▶ Ensure a safe vibration transmission and allow no elastic intermediate layers.
- ▶ Tighten the sensor with a tightening torque of 8 Nm.
- ▶ Use a conical washer on plane surfaces.
- ▶ Make a conical bore hole on tilted or curved surfaces.

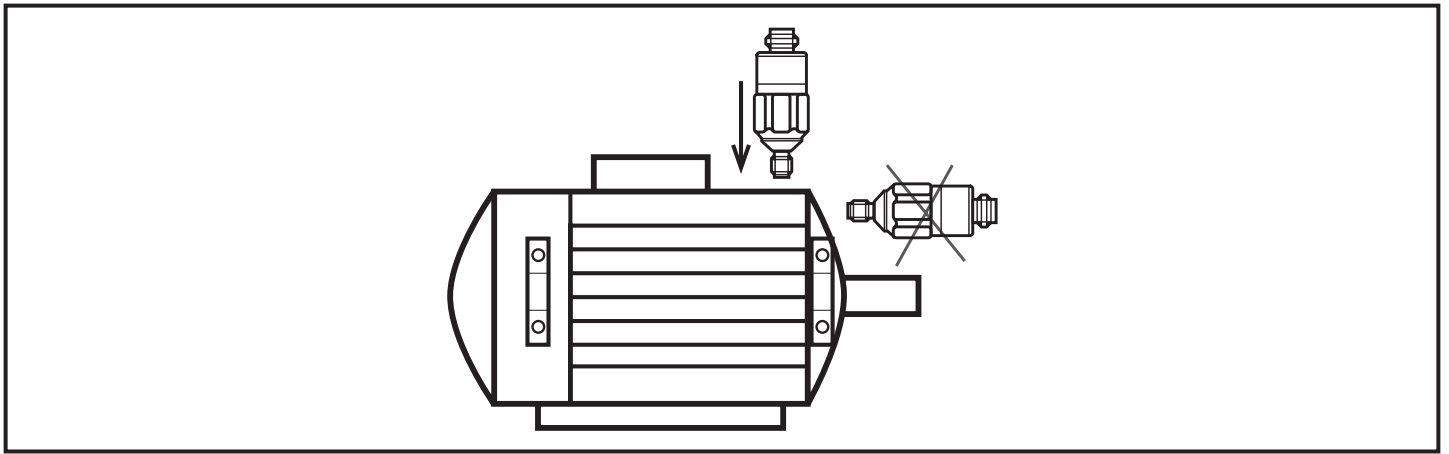

5.1 Making a conical bore hole

UK

In case of tilted or curved housing surfaces the mounting position must be prepared as follows:

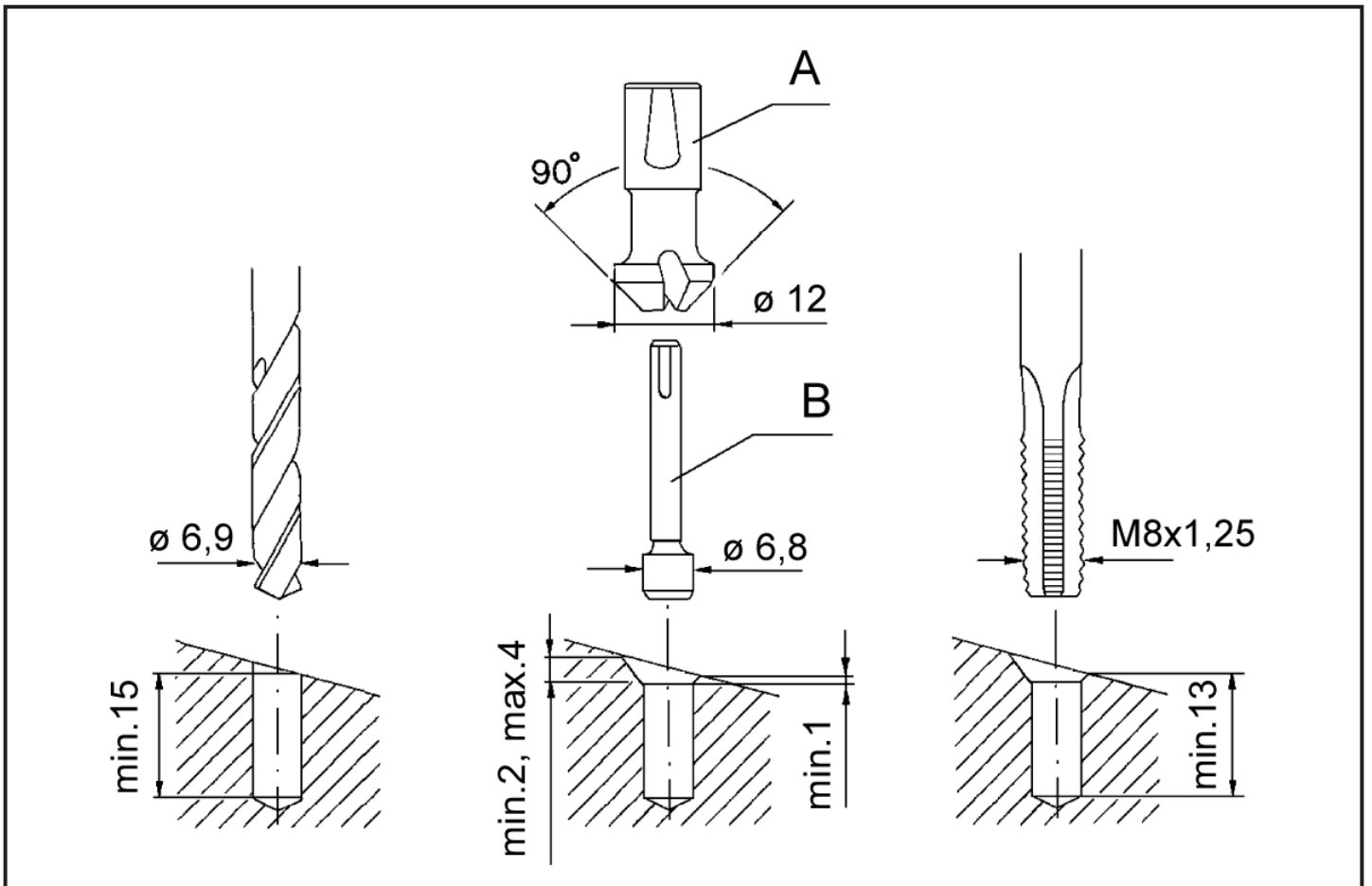

<p>1. Bore a hole with a $\varnothing 6.9$ mm drill</p>	<p>2. Make a 90° cone using a bevel cutter (A) and a centering insert (B) $\varnothing 6.8$ mm</p>	<p>3. Tap an M8 x 1.25 thread</p>
--	---	-----------------------------------

6 Scale drawing

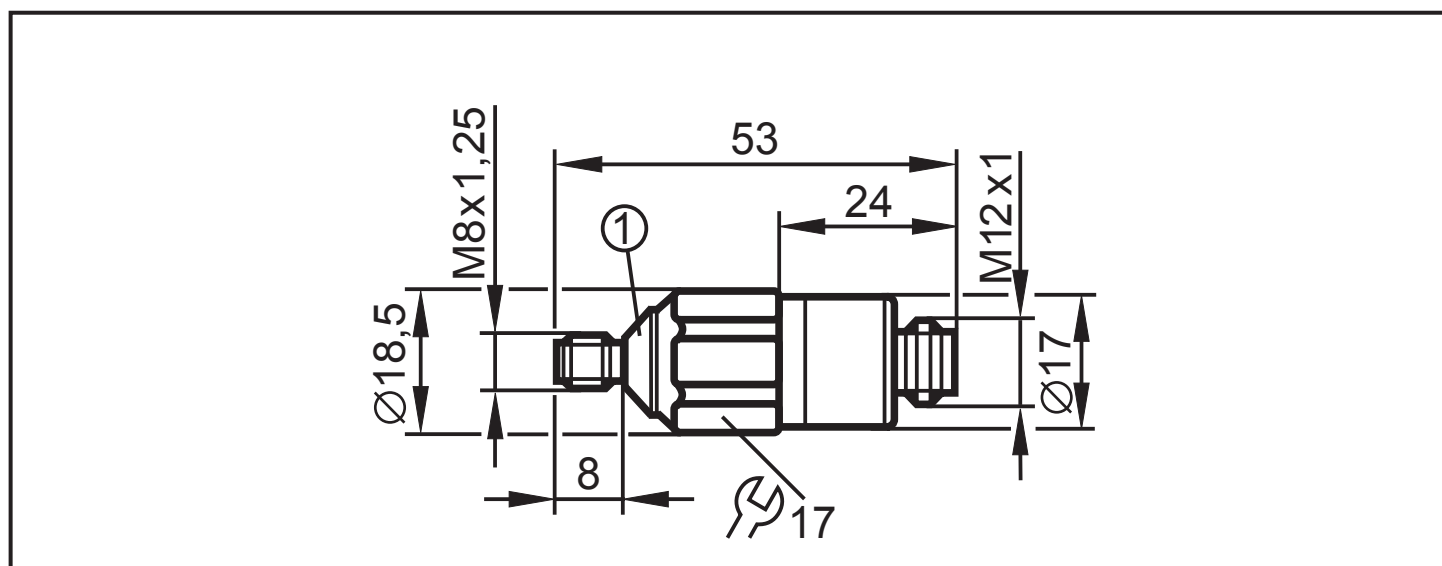

1: conical angle = 90°

7 Maintenance, repair and disposal

If used correctly no maintenance and repair measures are necessary. After use dispose of the unit in an environmentally friendly way in accordance with the applicable national regulations.

8 Technical data

Technical data and further information at
www.ifm.com --> Select your country --> Data sheet direct