

Newton2 Development Platform Hardware Manual

Date: Oct. 2014



北京君正集成电路股份有限公司
Ingenic Semiconductor Co., Ltd.

Newton2 Development Platform Hardware Manual

Release history

Date	Revision	Revision History
Oct. 29, 2014	1.0	- First released

Disclaimer

This documentation is provided for use with Ingenic products. No license to Ingenic property rights is granted. Ingenic assumes no liability, provides no warranty either expressed or implied relating to the usage, or intellectual property right infringement except as provided for by Ingenic Terms and Conditions of Sale.

Ingenic products are not designed for and should not be used in any medical or life sustaining or supporting equipment.

All information in this document should be treated as preliminary. Ingenic may make changes to this document without notice. Anyone relying on this documentation should contact Ingenic for the current documentation and errata.

Ingenic Semiconductor Co., Ltd.

Ingenic Headquarters, East Bldg. 14, Courtyard #10, Xibeiwang East Road, Haidian Dist., Beijing, China, 100193

Tel: 86-10-56345000

Fax: 86-10-56345001

Http: //www.ingenic.cn

CONTENT

1	OVERVIEW.....	1
1.1	HARDWARE FEATURES.....	1
1.2	BLOCK DIAGRAM	2
1.3	MODULE PHOTOS	3
2	HARDWARE COMPONENT DETAILS	4
2.1	INGENIC M200 PROCESSOR.....	4
2.2	POWER MANAGEMENT IC	4
2.3	STORAGE AND MEMORY.....	5
2.4	WI-FI/BT MODULE	5
2.5	GYROSCOPE/ACCELEROMETER/MAGNETOMETER SENSORS	6
2.6	LCD POWER DRIVE IC	7
3	CONNECTOR AND INTERFACE DETAILS.....	8
3.1	DISPLAY PANEL CONNECTOR.....	8
3.2	TOUCH SCREEN CONNECTOR.....	8
3.3	AUDIO CONNECTOR.....	9
3.4	CAMERA CONNECTOR	10
3.5	SENSOR & GPS CONNECTOR.....	10
3.6	KEY CONNECTOR	11
3.7	WI-FI/BT RF CONNECTOR	12
3.8	MOTOR INTERFACE.....	12
3.9	USB INTERFACE	12
3.10	UART INTERFACE	12
4	BOOT AND RESET	14
4.1	SYSTEM BOOT MODE	14
4.2	SYSTEM RESET	14

1 Overview

This document describes the hardware interface of the Ingenic Newton2 development board. It provides the detailed information of the on-board components and connectors.

The Ingenic® Newton2 development board is designed to lower the barriers to entry for anyone developing and producing the wearable and IoT devices. It integrates the Ingenic M200 wearable processor, eMCP, PMIC, Wi-Fi, Bluetooth and sensors on a very small module. It also provides several connectors for display, touch screen, audio, camera, keys, I2C/UART/GPIO, Wi-Fi/BT radio and other peripherals. The Ingenic M200 is a high integration and low power SoC that is dedicated for the wearable smart devices. It contains a dual-core MIPS-based XBurst CPU (1.2GHz/300MHz), a 3D GPU, a 720P VPU, an ISP for image pre-processing. It also supports many on-chip controllers and peripherals such as NAND/MMC/SDIO controllers, USB OTG controller, MIPI-DSI, MIPI-CSI, internal audio CODEC with voice trigger engine which enabling wakeup during sleeping. The Ingenic® Newton2 can run the latest version of Android and Linux operating system, which makes it easy for developers to build various device drivers and user applications on it.

1.1 Hardware Features

Component	Description
Processor	Ingenic M200 Wearable Processor (MIPS-based XBurst-HP/LP dual-core, 1.2GHz/300MHz) <ul style="list-style-type: none"> . GPU: 3D with OpenGL ES 2.0/1.1 compliant and OpenVG 1.1 . VPU: H.264 encoder and decoder 720P@30fps . ISP for image pre-processing
Memory	eMCP H9TP32A4GDCCPR (32Gb eMMC + 4Gb LPDDR2)
PMIC	Ricoh RC5T619 power management IC
Wi-Fi	Broadcom 43438 single-band 2.4GHz IEEE 802.11 b/g/n
Bluetooth	Bluetooth 4.1 (Bluetooth Low Energy), 2.1 + EDR
Sensor	InvenSense MPU-9250, 3-axis gyroscope + 3-axis accelerometer + 3-axis magnetometer
USB 2.0	Micro USB device
UART	Serial debug port
Connector	<ul style="list-style-type: none"> . Display (24-pin): MIPI-DSI and power signals for 320x320 1.63" AMOLED module . Touch (14-pin): I2C, power and interrupt signals for capacitive touch screen . Audio (14-pin): DMIC + AOHPL/R . Camera (16-pin): MIPI-CSI + I2C . Key (14-pin): POWER/WKUP_N, BOOT_KEY, BOOT_SEL1 . GPS/Sensor (18-pin): UART, I2C, GPIO . RF Connect (4-pin): Wi-Fi and 2.4GHz BT antenna <p>* All digital I/O pins can also be configured as GPIO.</p>
Clocks	24MHz, 32.768kHz; 26MHz (Wi-Fi/BT)
Dimensions	15 x 30 x 2.4 (mm)

1.2 Block Diagram

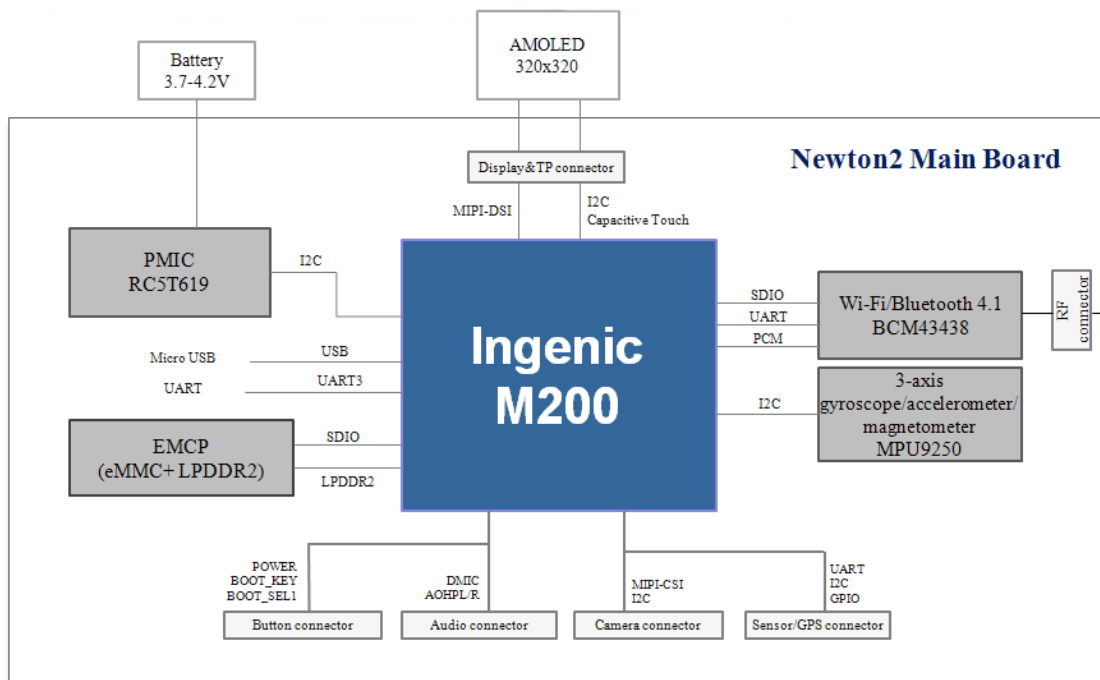
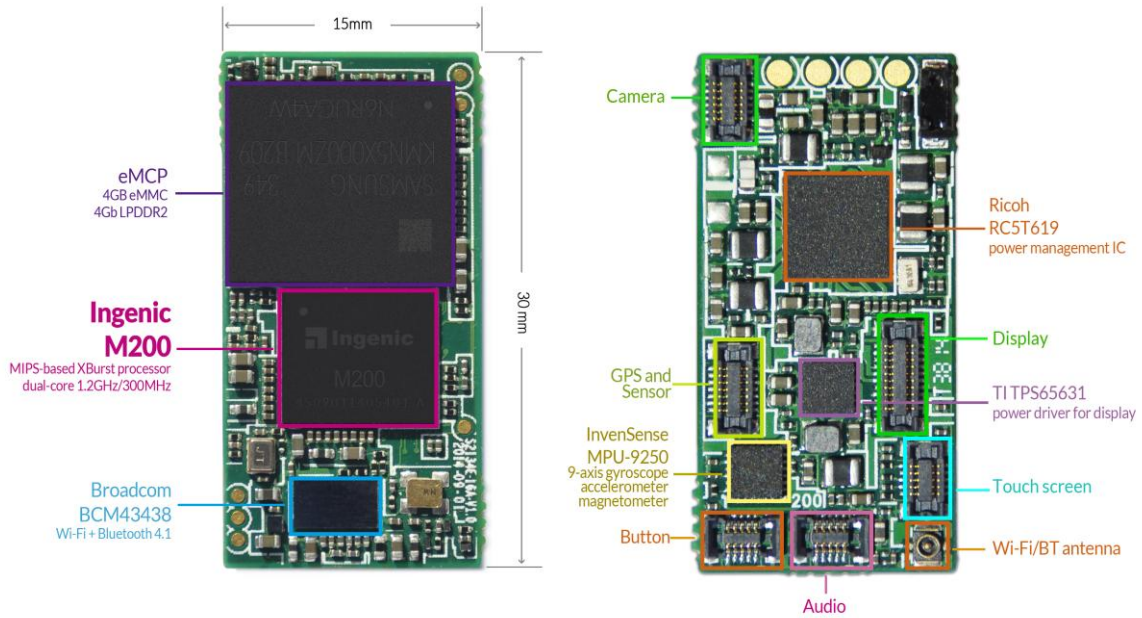

Figure 1 Newton2 Block Diagram

1.3 Module Photos



2 Hardware Component Details

This section describes every hardware module of the board. For details of the M200, please refer to the datasheet and programmer guide of the M200. For details of each component, please refer to relative component datasheet. For details of the board, please refer to board schematic.

2.1 Ingenic M200 processor

Ingenic M200 integrates two MIPS-based XBurst cores, one core up to 1.2GHz for high performance application, the other core up to 300MHz for low power application. The XBurst CPU core supports the MIPS compatible RISC, SIMD and FPU instruction set, and a 9-stage pipeline micro-architecture. M200 also includes 3D GPU, VPU, ISP for image pre-processing, and many other controllers and peripherals. In addition, it integrates an audio CODEC with voice trigger function, such that the processor can be wakeup via voice during sleep mode.

2.2 Power management IC

Newton2 uses the Ricoh RC5T619 Power Management IC. This IC is the power management IC for GPS-PND/MID and Smart-Phone. It integrates five high-efficiency step-down DCDC Converters, twelve low dropout regulators, power control logic, Li-ion Battery Charger, I2C-Bus Interface, voltage detections, thermal shut-down, and etc.

Features:

- System
 - I2C-Bus interface @3.4MHz and 400kHz
 - Detector Function (System/IO/Battery-Voltage-detector, UVLO)
 - Thermal Shutdown Function
 - Watchdog timer
 - Power on key input for System's power up
 - Power on reset output for CPU
 - Flexible power-on/off sequence by OTP
 - Flexible DCDCx and LDOx default-on/off control by OTP
- High Efficiency Step-down DC/DC Converters
 - DCDC1-3 0.6V-3.5V Max 3000mA
 - DCDC4-5 0.6V-3.5V Max 2000mA
 - Soft-start circuit
- Low Drop Voltage Regulators
 - LDO1-4 with ECO 0.9V-3.5V Max 300mA
 - LDO5-6 with ECO 0.6V-3.5V Max 300mA
 - LDO7-10 0.9V-3.5V Max 200mA
 - LDORTC1 1.7-3.5V Max 10mA (AlwaysOn, For coin battery)
 - LDORTC2 0.9-3.5V Max 10mA (AlwaysOn)
 - Over current Protection and Short circuit Protection

- Li-ion Battery Charger
 - Supports AC adapter charging and USB charging in an individual port
 - With the current limit protection and charge current control
 - The system can power on even when Li-ion Battery is low voltage or open
 - Rapid timer and Trickle timer
 - Power-path control
 - Over temperature protection
- USB External device interface
- Fuel Gauge
- ADC
 - 12-bit resolution A/D converter
 - Eight channels: LIMMON, VADP, VUSB, VBAT, VSYS, THERMBAT and two external(GPIO) pins
 - Single/Auto conversion mode
 - Detect high/low thresholds which can be set
- 5ch-GPIO
- Real-Time Clock (RTC) for alarm function
- Interrupt Controller (INTC)

2.3 Storage and memory

Newton2 uses a eMCP which integrates a 4GB eMMC flash and a 512MB LPDDR2 memory.

Features:

[e-NAND]

- Packaged NAND flash memory with MultiMedia-Card interface
- eMMC Bus mode
 - High-speed eMMC protocol.
 - Data bus width: 1 bit, 4 bits, 8 bits(default)
 - Data transfer rate: up to 200Mbyte/s
- Error free memory access
 - Internal error correction code.
 - Internal enhanced data management algorithm(Wear levelling, Bad block management, Garbage collection).
 - Possibility for the host to make sudden power failure safe-update operations for data content.
- LPDDR2
 - 8 banks (Bank address BA0~BA2)
 - Row address R0~R13
 - Column address C0~C9
 - Data bus width: 32 bits

2.4 Wi-Fi/BT module

Newton2 uses the Broadcom single-chip Wi-Fi/BT/FM module BCM43438. The Broadcom BCM43438 is a highly integrated single-chip solution and offers the lowest RBOM in the industry for smartphones and a wide range of other portable devices. The chip includes a 2.4GHz WLAN IEEE

802.11 b/g/n MAC/baseband/radio, Bluetooth 4.1 support, and an FM receiver. In addition it integrates a power amplifier (PA) that meets the output power requirements of most handheld systems, a low-noise amplifier (LNA) for best-in-class receiver sensitivity, and an internal transmit/receive (iTR) RF switch, further reducing the overall solution cost and printed circuit board area.

Features:

- Single-band 2.4GHz IEEE 802.11 b/g/n
- Single-stream IEEE 802.11n
- Integrated iTR switch supports a single 2.4GHz antenna shared between WLAN and Bluetooth
- Supports standard SDIO v2.0 and gSPI host interfaces
- Complies with Bluetooth Core Specification Version 4.1 with provisions for supporting future specifications.
- Bluetooth Class 1 or Class 2 transmitter operation
- Host Controller Interface (HCI) using a high-speed UART interface and PCM for audio data.
- Security:
 - WPA and WPA2 (personal) support for powerful encryption and authentication.
 - AES in WLAN hardware for faster data encryption and IEEE 802.11i compatibility.
 - Reference WLAN subsystem provides Cisco Compatible Extensions (CCX, CCX 2.0, CCX 3.0, CCX 4.0, CCX 5.0).
 - Reference WLAN subsystem provides Wi-Fi protected setup (WPS).

2.5 Gyroscope/Accelerometer/Magnetometer sensors

Newton2 integrates the InvenSense MPU-9250, a multi-chip module (MCM) consisting of two dies integrated into a single QFN package. One die houses the 3-Axis gyroscope and the 3-Axis accelerometer. The other die houses the AK8963 3-Axis magnetometer from Asahi Kasei Microdevices Corporation. Hence, the MPU-9250 is a 9-axis MotionTracking device that combines a 3-axis gyroscope, 3-axis accelerometer, 3-axis magnetometer and a Digital Motion Processor™ (DMP) all in a small 3x3x1mm package.

Features:

- Gyroscope Features
 - Digital-output X-, Y-, and Z-Axis angular rate sensors (gyroscopes) with a user-programmable full-scale range of ± 250 , ± 500 , ± 1000 , and $\pm 2000^\circ/\text{sec}$ and integrated 16-bit ADCs.
 - Digitally-programmable low-pass filter.
 - Factory calibrated sensitivity scale factor
 - Gyroscope operating current: 3.2mA; Sleep mode current: 8 μ A.
- Accelerometer Features
 - Digital-output triple-axis accelerometer with a programmable full scale range of $\pm 2g$, $\pm 4g$, $\pm 8g$ and $\pm 16g$ and integrated 16-bit ADCs.
 - User-programmable interrupts.
 - Wake-on-motion interrupt for low power operation of applications processor.

- Accelerometer normal operating current: 450 μ A
- Low power accelerometer mode current: 8.4 μ A at 0.98Hz, 19.8 μ A at 31.25Hz
- Sleep mode current: 8 μ A
- Magnetometer Features
 - 3-axis silicon monolithic Hall-effect magnetic sensor with magnetic concentrator
 - Wide dynamic measurement range and high resolution with lower current consumption
 - Output data resolution of 14 bit (0.6 μ T/LSB) or 16 bit (15 μ T/LSB)
 - Magnetometer normal operating current: 280 μ A at 8Hz repetition rate
- Additional Features
 - Auxiliary master I2C bus for reading data from external sensors (e.g. pressure sensor)
 - 3.5mA operating current when all 9 motion sensing axes and the DMP are enabled
 - 4096 byte FIFO buffer enables the applications processor to read the data in bursts
 - Digital-output temperature sensor
 - User-programmable digital filters for gyroscope, accelerometer, and temp sensor
 - 400kHz Fast Mode I2C for communicating with all registers
 - 1MHz SPI serial interface for communicating with all registers
 - 20MHz SPI serial interface for reading sensor and interrupt registers
- MotionProcessing
 - Internal Digital Motion Processing™ (DMP™) engine supports advanced MotionProcessing and low power functions such as gesture recognition using programmable interrupts.
 - Low-power pedometer functionality allows the host processor to sleep while the DMP maintains the step count.

2.6 LCD power drive IC

Newton2 uses the TI TPS65631 for the LCD/OLED display drive. The TPS65631 is designed to drive AMOLED (Active Matrix Organic Light Emitting Diode) displays requiring positive and negative supply rails. The device integrates a boost converter for VPOS and an inverting buck boost converter for VNEG and is suitable for battery-operated products. The digital control pin (CTRL) allows programming the negative output voltage in digital steps.

Features:

- 2.9–V to 4.5–V Input Voltage Range
- Fixed 4.6–V Positive Output Voltage
- 0.5% VPOS Accuracy from 25°C to 85°C
- Separate VPOS Output Sense Pin
- Negative Output Voltage Digitally Programmable from -1.4 V to -4.4 V (-4 V Default)
- Output Currents up to 250 mA Supported
- Excellent Line Transient Regulation
- Short-Circuit Protection
- Thermal Shutdown

3 Connector and Interface Details

3.1 Display Panel Connector

The display panel connector on the Newton2 board supports the MIPI-DSI type of the display module. This connector can be used to connect the AUO 1.63" color AMOLED display module.

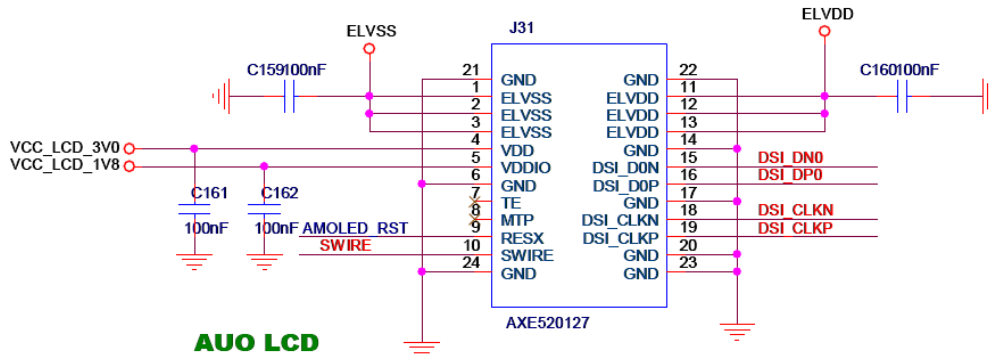

Table 3 Display Panel Connector (J31) Signals Definition

Pin Number	Signal name	I/O	Description
1,2,3	ELVSS	PWR	AMOLED power negative
11,12,13	ELVDD	PWR	AMOLED power positive
4	VDD	PWR	Power supply for analog
5	VDDIO	PWR	Power supply for Interface except MIPI interface
9	RESX	DO	Device reset signal (0 : Enable ; 1: Disable)
10	SWIRE	DI	SWIRE signal for PWR IC control
15	DSI_D0N	DIO	MIPI data negative signal
16	DSI_D0P	DIO	MIPI data positive signal
18	DSI_CLKN	AIO	MIPI strobe negative signal
19	DSI_CLKP	AIO	MIPI strobe positive signal

3.2 Touch Screen Connector

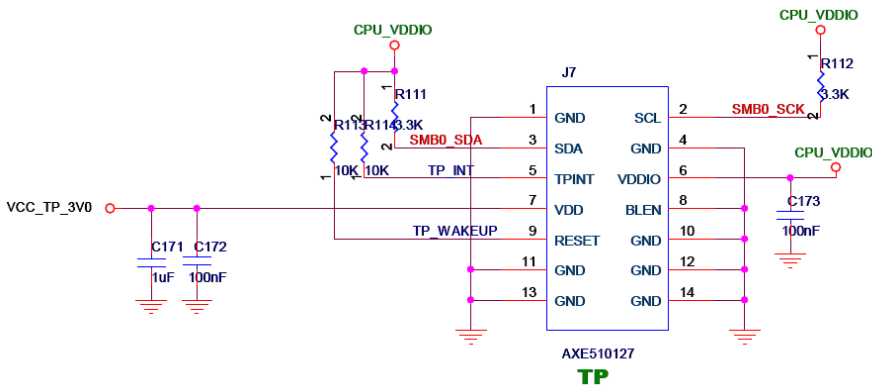
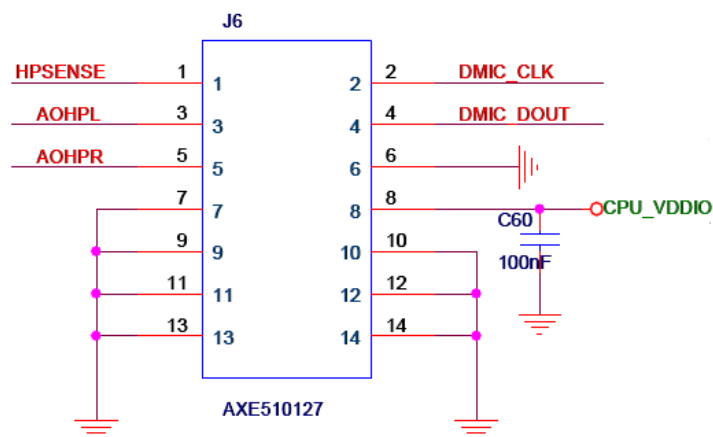

Table 2-3 Touch Screen Connector (J8) Signals Definition

Pin Number	Signal name	I/O	Description
2	SMB0_SCK	DIO	SMB 0 serial clock
3	SMB0_SDA	DIO	SMB 0 serial data
5	TP_INT	DI	Touch screen interrupt signal
6	CPU_VDDIO	PWR	Power CPU_VDDIO
7	VCC_TP_3V0	PWR	Power VCC_TP_3V0
9	TP_WAKEUP	DO	Touch screen reset signal

3.3 Audio Connector

Table 2-3 Audio Connector (J6) Signals Definition

Pin Number	Signal name	I/O	Description
1	HPSENSE	AI	Headphone jack sense
2	DMIC_CLK	DO	Digital MIC clock output
3	AOHPL	AO	Left headphone single-ended analog output
4	DMIC_DOUT	DI	Digital MIC data input
5	AOHPR	AO	Right headphone single-ended analog output
8	CPU_VDDIO	PWR	Power 3.3V
6,7,9,10,11, 12,13,14	GND	GND	Ground

3.4 Camera Connector

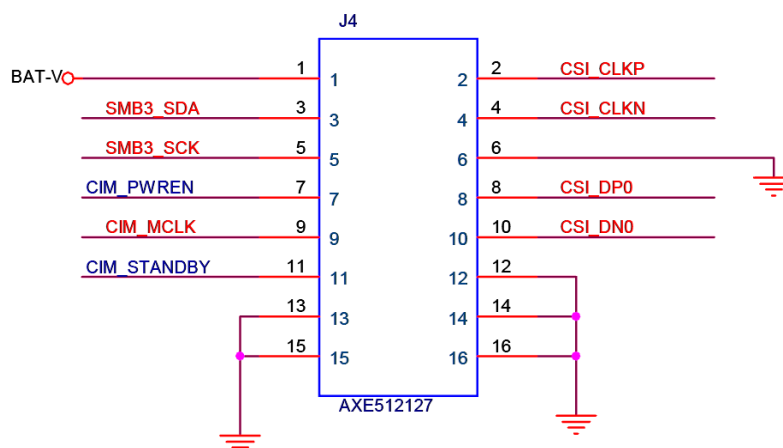
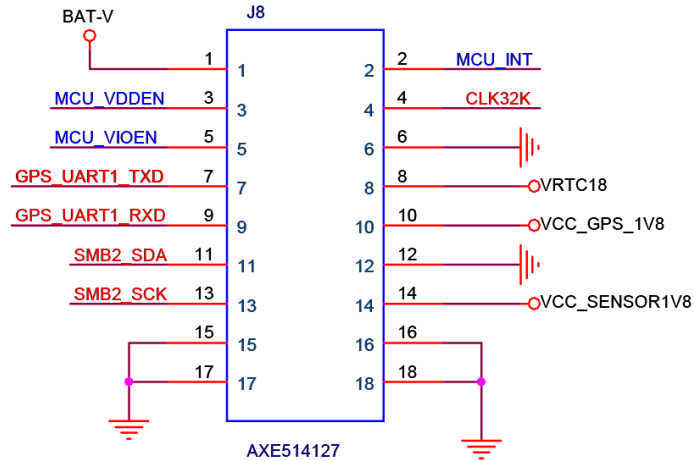

Table 2-3 Camera Connector (J4) Signals Definition

Pin Number	Signal name	I/O	Description
1	BAT-V	PWR	Battery power supply 3.7-4.2V
2	CSI_CLKP	AIO	Positive DPHY differential clock line transceiver input
3	SMB3_SDA	DIO	SMB 3 serial data
4	CSI_CLKN	AIO	Negative DPHY differential clock line transceiver input
5	SMB3_SCK	DIO	SMB 3 serial clock
7	CIM_PWREN	DO	Power enable control signal
8	CSI_DP0	AIO	Positive DPHY differential data line transceiver input, lane0
9	CIM_MCLK	DO	CIM master clock output
10	CSI_DN0	AIO	Negative DPHY differential data line transceiver input, lane0
11	CIM_STANDBY	DO	Standby control signal
6,12,13,14, 15,16	GND	GND	Ground

3.5 Sensor & GPS Connector

Table 2-3 Sensor & GPS Connector (J8) Signals Definition

Pin Number	Signal name	I/O	Description
1	BAT-V	PWR	Battery power supply 3.7-4.2V
2	MCU_INT	DIO	Interrupt signal
3	MCU_VDDEN	DIO	VDD enable signal
4	CLK32K	DO	32.768kHz clock output
5	MCU_VIOEN	DIO	VIO enable signal
7	GPS_UART1_TXD	DO	UART 1 transmitting data
8	VRTC18	PWR	VRTC18
9	GPS_UART1_RXD	DI	UART 1 Receiving data
10	VCC_GPS_1V8	PWR	VCC_GPS_1V8
11	SMB2_SDA	DIO	SMB 2 serial data
13	SMB2_SCK	DIO	SMB 2 serial clock
14	VCC_SENSOR1V8	PWR	VCC_SENSOR1V8
6,12,15,16, 17,18	GND	GND	Ground

3.6 Key Connector

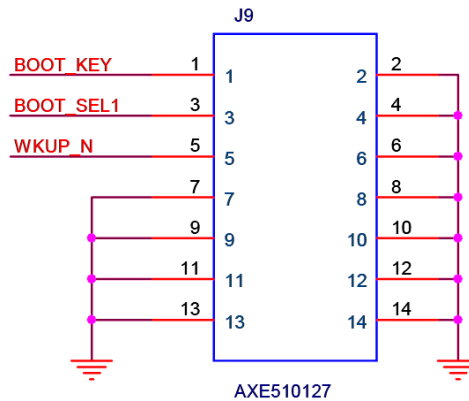
Table 2-3 Sensor & GPS Connector (J8) Signals Definition

Pin Number	Signal name	I/O	Description
1	BOOT_KEY	DIO	BOOT_KEY
3	BOOT_SEL1	DI	Boot select bit1 for MSC0 boot(=0) or USB boot (=1)
5	WKUP_N	DI	POWER/Wakeup key

3.7 Wi-Fi/BT RF Connector

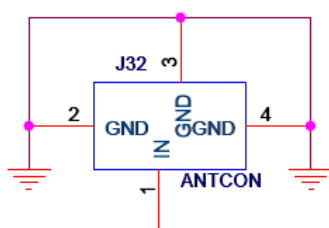

J32 is the connector for the Wi-Fi/BT antenna. Pin 1 is the RF output from the Wi-Fi/BT module.

3.8 Motor Interface

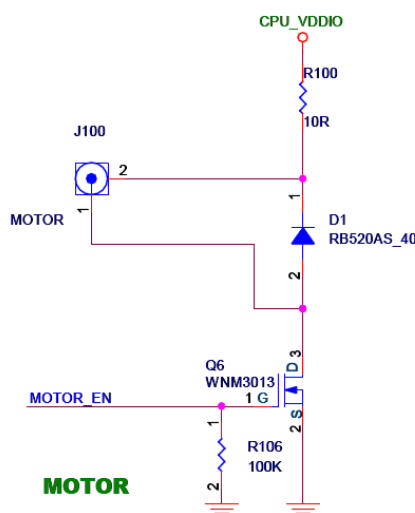

Newton2 can be connected with the motor. The motor welding point is showed in above figure.

3.9 USB Interface

Newton2 supports the USB 2.0 device. There are 4 test points USB_DP0/USB_DM0/VBUS/GND on the board. The Micro USB interface can be used as a power supply to the board, or used as a USB slave device after system booted, or used to download code to the eMMC flash.

3.10 UART Interface

There are three UART3 test points UART3_TX/UART3_RX/GND on the Newton2 board. You can connect the test points to the UART external board for debugging.

Note 1*:

PWR – Power signal

GND – Ground

AIO – Analog I/O

DIO – Digital I/O

DI – Digital Input from peripheral to M200

DO – Digital Output from M200 to peripheral

Note 2*: All digital I/O can also be configured as general purpose IO (GPIO).

4 Boot and Reset

4.1 System Boot Mode

Newton2 board has two boot modes:

- MSC0 (eMMC) for system boot
- USB boot for burning images

Table 41 BOOT SETUP

BOOT_SEL1 key	Boot From
BOOT_SEL1=0	MSC0 boot
BOOT_SEL1=1	USB boot

4.2 System Reset

When keep pressing the POWER/WKUP_N key down for about 5 seconds, the PMIC will send RESET signal to the CPU. The system will start booting from MSC0 or USB mode according the BOOT_SEL1 key value.

When you get the Newton2 board, it has been initialized with a demo system. Follow next steps to boot the system:

- Connect the debug board to the Newton2 board via serial and USB, the serial port configuration is 57600-8-n-1.
- Connect the battery to the Newton2 board.
- Connect the USB cable from the debug board to the PC. (not necessary)
- Press the POWER/WKUP_N key about 5s, then the board will be booted.