

Isolator Relay Delay/E

Date datasheet created:
19/04/2013

Service Manual

The Battery Isolator Relay Delay/E is a reliable approach to charging multiple batteries on a vehicle. It provides a delay to allow the engine to briefly "warm up" and to recharge the main battery before placing the heavy load of a discharged auxiliary battery on the alternator. It also allows the use of self-exciting alternators.

How It Works

Isolator Function

The unit operates as an isolator by sensing the level of voltage on the chassis 12 volt system. When this voltage goes above 13.3 volts for approximately 12 seconds, as happens when the engine is running normally (normal alternator output voltage is approximately 14.4 volts), it will close the isolator relay providing charging current to the coach battery. When the ignition switch is turned off, the relay will open immediately.

If the voltage should fall below 12 volts for more than two seconds while the ignition is on, the relay will drop out to feed all the alternators available output to the chassis battery to keep the engine running. This might happen when the alternator is not able to supply sufficient current to all of the loads. When the chassis voltage goes above 13.3 volts again, the relay will again close in about two seconds to retry and charge the coach battery. The resultant flickering of lights would alert the driver of the system overload.

Trouble Shooting

Problem

Coach battery not charging

Possible Cause / Solution

With engine running, chassis voltage must be above 13.5 volts (Blue wire) If less 13.3 volts, check vehicle's charging system

Check ground on module (Black wire)

Check for voltage on coil of isolator relay after engine has been running for at least 20 seconds. (Red wire). Voltage should be approximately 12 volts. If no voltage, replace IRD/E.

If 12 volts is applied to isolator relay coil, check for voltage drop across the isolator relay contacts. If the drop is greater than 0.3 volts, replace relay.

Problem

Chassis battery continues to drain

Possible Cause / Solution

Check voltage on module with ignition off. (Red and Blue wire) should be 0 volts. If not, check wiring.

Check for continuity across the isolator relay contacts, the relay should be open with no voltage applied to coil.



CAUTION:

The Isolator Relay Delay/E controls the Isolator Relay which is connected directly to the chassis and coach batteries. Power from both the batteries is fed into the module. The full power of the battery is available at this module. Inadvertant shorts at this box could result in damage and/or injury.

All servicing of this module should be done only by a qualified Service Technician

Tools required: Low current Test Light, Accurate Voltmeter (digital read-out preferred)

Isolator Relay Delay/E

Date datasheet created:
19/04/2013

Typical Installation Diagram

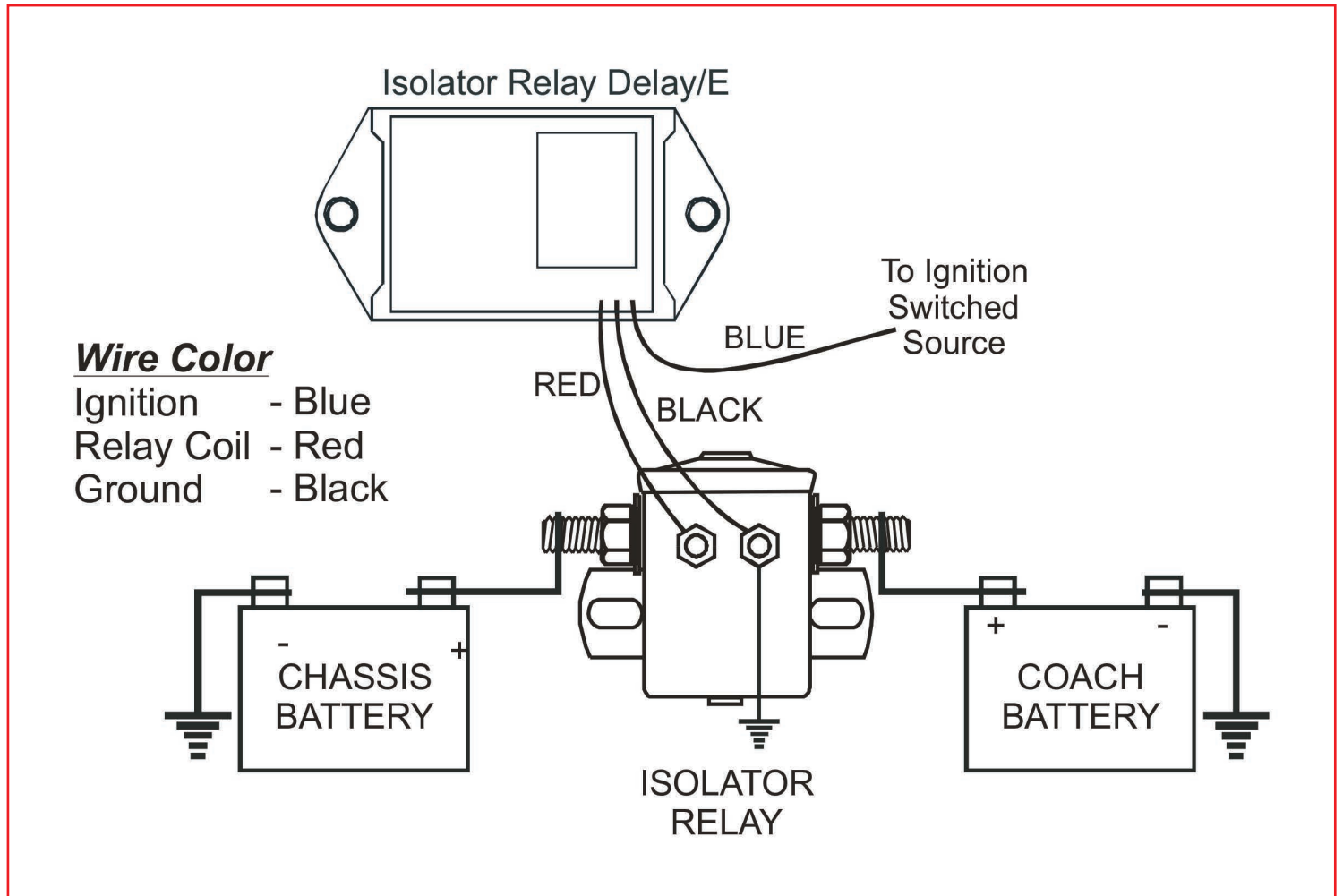

For further information on this product, please contact Intellitec.