

Quad "H" Bridge Output Module

Date datasheet created:
19/07/2013

The Quad "H" Bridge Module is a member of Intellitec's Multiplex Control family. It works in combination with the PMC CPU and other standard, semi-custom, or custom I/O modules.

The 916-120 provides power fusing, switching, and distribution all in one module. It would typically be used to operate reversible motor loads. This module has eight, 10 amp SPDT relays connected in four "H" bridge configurations. When a channel is activated, it connects one end of the load to the Battery, while the other end is connected to Ground. Each of the four "H" bridges is fed from a fuse position that can be filled with a fuse, or circuit breaker. The total module current should not exceed 20 Amps.

The Quad "H" Bridge Module includes 9 diagnostic LED's. One indicates the loss of the communication signal and the others indicate the activation of the individual outputs.

Each of the first eight channels will turn on one of the relays in the four "H" bridges. A channel 9 signal will turn on all the odd numbered channel relays and channel 10 signal will turn on all the even channels. This allows simultaneous operation of the four motor loads with a single input.

Each of the outputs can also be used as individual outputs with the understanding that the load will be grounded when turned off. This allows the module to power up to 8 individual loads.

For further information on this product, please contact Intellitec.



PAT NO. 4,907,222 & 6,011,997

All of the output harnesses are connected with AMP Mate-N-Lok connectors to reduce installation time and errors.

The approximate module dimensions are: 5.8" X5.0"X1.45" (147mm X127mm X36mm).

The module should be installed in a protected environment, inside the vehicle

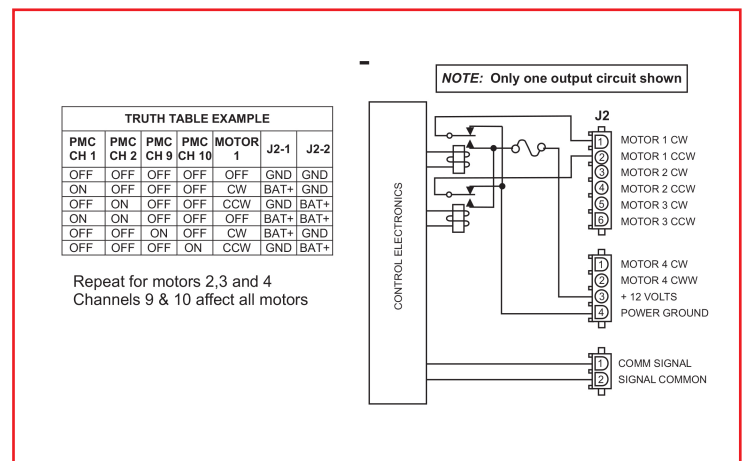

Quad "H" Bridge Output Module

Date datasheet created:
19/07/2013

Specifications

General Connections		00-00916-120
Nominal Vehicle Voltage		12V
Module Current		20 Amp Max
J4-3	+ 12 Volts	
J4-4	Ground	
J1-1	PMC Signal	18 awg Min
J1-2	PMC Ground	14 awg Min

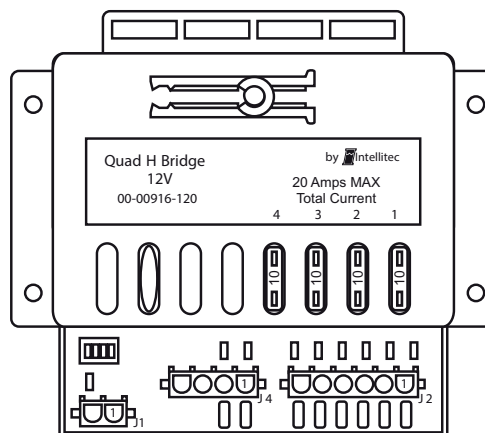

CHANNEL DESIGNATIONS

Channel	Relay	Connection	Type	Fuse	Rating
1	Relay 1	J2-1	Relay Output, Form C (SPDT)	Fuse 1	10 Amp Max
2	Relay 2	J2-2	Relay Output, Form C (SPDT)	Fuse 1	10 Amp Max
3	Relay 3	J2-3	Relay Output, Form C (SPDT)	Fuse 2	10 Amp Max
4	Relay 4	J2-4	Relay Output, Form C (SPDT)	Fuse 2	10 Amp Max
5	Relay 5	J2-5	Relay Output, Form C (SPDT)	Fuse 3	10 Amp Max
6	Relay 6	J2-6	Relay Output, Form C (SPDT)	Fuse 3	10 Amp Max
7	Relay 7	J3-1	Relay Output, Form C (SPDT)	Fuse 4	10 Amp Max
8	Relay 8	J3-2	Relay Output, Form C (SPDT)	Fuse 4	10 Amp Max
9	All Odd Number Relays ON				
10	All Even Number Relays ON				

NOTE:

The relays provide a fused source of voltage to the Load from the Battery when ON and Ground when OFF.

MATING CONNECTIONS

Designator	Function	Connector	Mating Part #	Contact, Typical
J1	PMC/Com	2 Pin Amp Mate-N-Lok	1-480698-0	350919-3
J2	Outputs	6 Pin Amp Mate-N-Lok	640585-1	350919-3
J4	Outputs/Power	4 Pin Amp Mate-N-Lok	1-480700-0	350919-3

MODULE SETTINGS

Module can be set for 1 of 16 address.
Set four position dip switch per table to the right.

X = Switch OFF

DIP SW	MODULE	DIP SW	MODULE
4 3 2 1	Address	4 3 2 1	Address
0 0 0 0	A	X 0 0 0	I
0 0 0 X	B	X 0 0 X	J
0 0 X 0	C	X 0 X 0	K
0 0 X X	D	X 0 X X	L
0 X 0 0	E	X X 0 0	M
0 X 0 X	F	X X 0 X	N
0 X X 0	G	X X X 0	O
0 X X X	H	X X X X	P