

# Bi-Directional Isolator Relay Delay

Date datasheet created:  
16/05/2013

Intellitec's Bi-Directional Isolator Relay Delay offers a new approach to charging batteries in an RV application. Unlike prior systems that only allowed charging the RV battery from the engine's alternator, the Bi-Directional Isolator Relay Delay charges both batteries when either one is being charged. When the coach is being driven, both batteries will be charged from the engine's alternator. When the coach is plugged into shore power, both batteries will be charged from the converter. If neither battery is being charged, the batteries are fully isolated. The controller also senses heavy loads on either battery to prevent the wrong battery from being inadvertently discharged.

The unit is housed in a plastic enclosure for mounting in an engine compartment. It operates in combination with a conventional continuous duty solenoid to connect the two batteries together under the proper conditions.

It operates by sensing the voltages on both batteries. When either of these voltages exceeds 13.3 volts for approximately 1 minute, which happens when either battery is being charged, the control will close the isolator solenoid, connecting the two batteries together, charging them both. (Normal charging voltages are from approximately 13.8 to 14.4 volts.)

After the solenoid has been closed, the system continues to sense the voltage. If the ignition switch is off and the battery voltage drops below 12.8 volts for approximately 1 minute, which might occur when the converter is heavily loaded, the solenoid is opened to prevent the chassis battery from being discharged by the coach loads. When the voltage goes above 13.3 volts again for approximately 1 minute, the solenoid closes again.

If the ignition switch is on, the control allows the voltage drop below 12.6 volts for approximately 1 minute, before the solenoid is opened to insure the alternator's full output is available for important chassis functions. When the voltage goes above 13.3 volts again for approximately 1 minute, the solenoid will close.

## How Does It Work?

The Bi-Directional Isolator Relay Delay constantly senses the voltage on the coach and chassis batteries. If either voltage is above 13.3 volts, which indicates the batteries are being

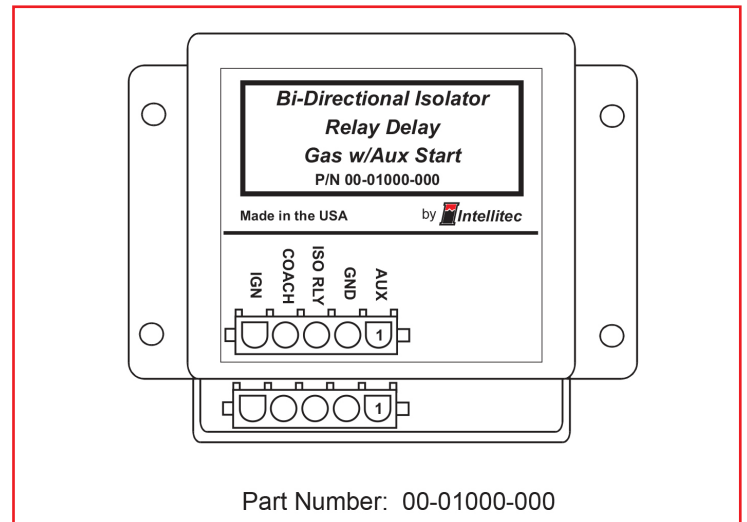

Part Number: 00-01000-000

charged, the control closes the isolator relay. This parallels the batteries, charging them both. If the ignition is off and the voltage falls below 12.8 volts for approximately 1 minute, the relay will open to prevent the coach loads from discharging the chassis battery. When the voltage goes back above 13.3 volts for approximately a minute, the relay will close again.

If the ignition is on and the voltage falls below 12.6 volts for approximately 1 minute, the relay will open to prevent the coach loads from discharging the chassis battery. When the voltage goes back above 13.3 volts, for approximately a minute, the relay will close again. Allowing the batteries to stay connected together to a lower voltage helps charge a heavily discharged coach more quickly with the varying output of the alternator.

## Specifications

Part Number:	00-01000-000
Output Current:	1 Amp maximum
Standby Current:	Less than 2 milliamps
Ambient Temperature Range:	-40 C to +85 C
Normal Input Voltage Range:	10 to 18 volts
Short Term Over Voltage Protection to:	+26 volts
Reverse Voltage Protection to:	-300 volts
positive Voltage Spike Protection to:	+150 volts
Operating Environment:	Out of direct weather

# Bi-Directional Isolator Relay Delay

Date datasheet created:  
16/05/2013

## Typical Installation Diagram

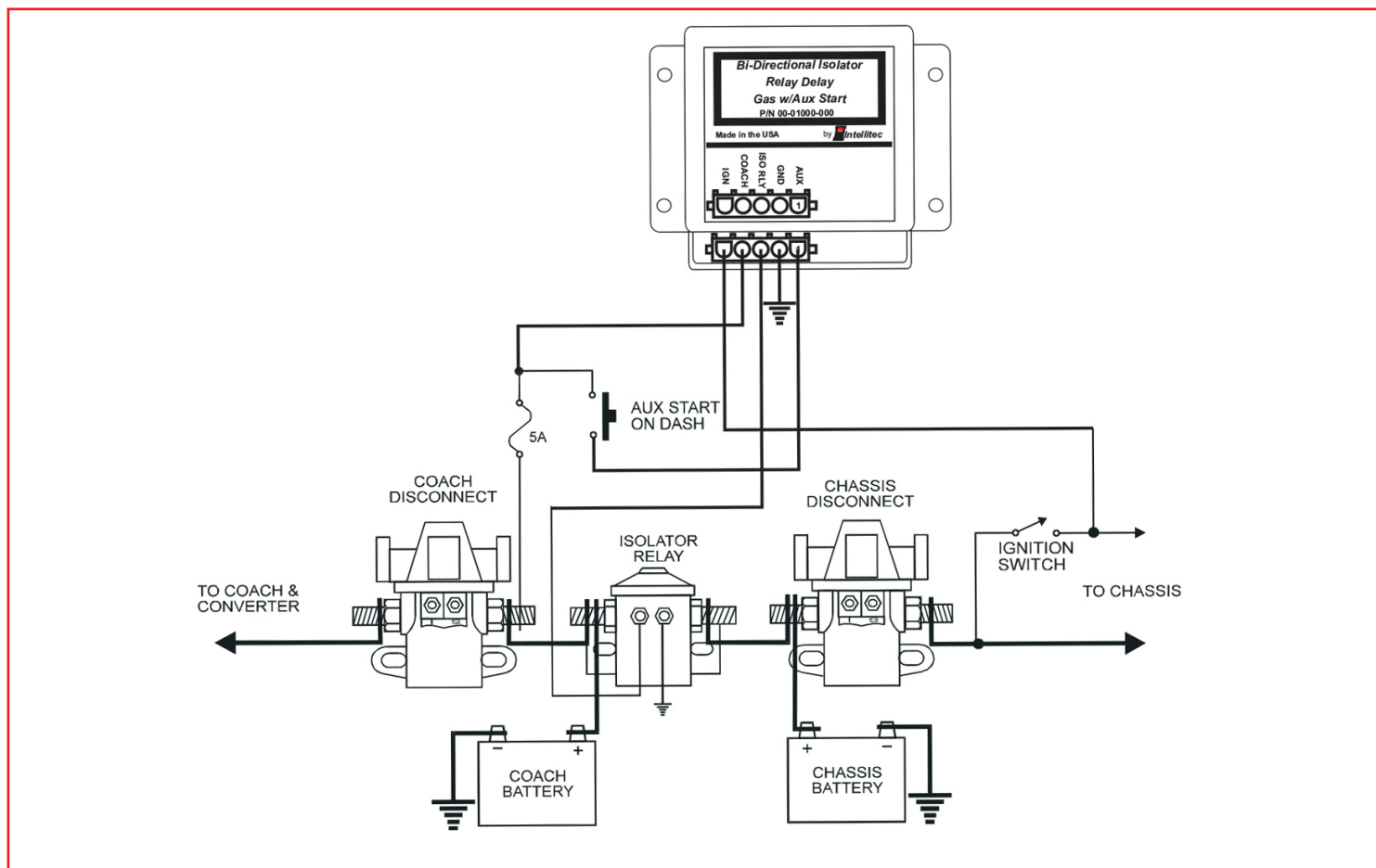

For further information on this product,  
please contact Intellitec.