

Intematix ChromaLit™ Contour *Remote Phosphor Light Source*

ChromaLit Contour light sources create the next generation LED lamps by offering omni-directional lighting distribution, improved light quality, and scalability to all wattages. These remote phosphor light sources are offered with Intematix's patented A-lamp reference design, which delivers up to 1100 lumens in an A19 form factor and up to 2600 lumens in an A21 form factor.

Features & Benefits

- Omni-directional light distribution
- Meets ENERGY STAR requirements
- Glare-free LED light bulb design
- Exceptional color quality and color consistency
- Scalable to all wattages
- Increased efficacy reduces thermal and electrical load
- Up to 2600 lumens reference design
- Rugged and environmental
- Supports long lifetime applications up to 50,000 hours

Application & Uses

- 450 lumens - 2600 lumens omni-directional LED A-lamp



ChromaLit Contour



A19 Reference Design

TABLE OF CONTENTS

Product Nomenclature	3
Optical Characteristics	4
Relative Spectral Power Distribution	5
Intensity Distribution	5
Performance Characteristics Over Wavelength	6
Relative Conversion Characteristics over Temperature	6
Absolute Maximum Ratings	7
Mechanical Characteristics	7
Company Information	9

Product Nomenclature

ChromaLit products are identified by the following product nomenclature:

Product order code

CL-ABC-DEFGH-IJ

Where:

A - Designates first digit in CRI

BC - Designates the first two digits in CCT

DEF - Designates shape (CTR = Contour)

GH - Designates equivalent incandescent wattage (75, 100, 150)

IJ - Designates product family

Example:

CL-827-CTR75-PC represents ChromaLit Contour 75 watt equivalent, 80CRI, 2700K CCT, polycarbonate family

Optical and Performance Characteristics¹

Color Designation	CCT ² (K)	Color Consistency ³ MacAdam Ellipses	Min CRI ⁴	Minimum Conversion Efficacy ⁵ (Lm/W _{rad}) at 25°C	Typical Conversion Efficacy ⁵ (Lm/W _{rad}) at 25°C
CL-827	2700	3-step	90	175	185
CL-927	2700	3-step	90	130	145
CL-830	3000	3-step	80	185	195
CL-930	3000	3-step	90	140	150
CL-850	5000	4-step	80	190	200

Notes

1. Performance based on reference design. Please refer to application note for details on reference design. Intematix maintains a tolerance of $\pm 7\%$ of luminous flux and radiant watt measurements. Intematix maintains a tolerance of 0.5 MacAdam Ellipses on color consistency measurements.
2. **Correlated Color Temperature**
3. **Color Consistency** is dependent on the AVERAGE dominant wavelength of blue LED source. ChromaLit maintains color consistency within a 3-step MacAdam Ellipse given a uniform blue LED source with a constant average wavelength. 2.5nm (± 1.25 nm) of average blue LED wavelength variation will provide 4-step MacAdam Ellipses of color consistency. Values are approximate, please refer to bin diagram on the following page for exact bin definition.
4. **Minimum Color Rendering Index** rating is based on reference design using blue LEDs with average dominant wavelength of 455nm. Please refer to page 6 for more information on performance characteristics over wavelength.
5. **Conversion Efficacy** is the luminous flux (white light) output per radiant watt of blue light input to ChromaLit. W_{rad} is the radiometric power measured in watts. Conversion efficacy is rated based on reference operation and dominant blue LED wavelength of 455nm (peak wavelength of 450nm).

Optical and Performance Characteristics

ChromaLit Binning Diagram

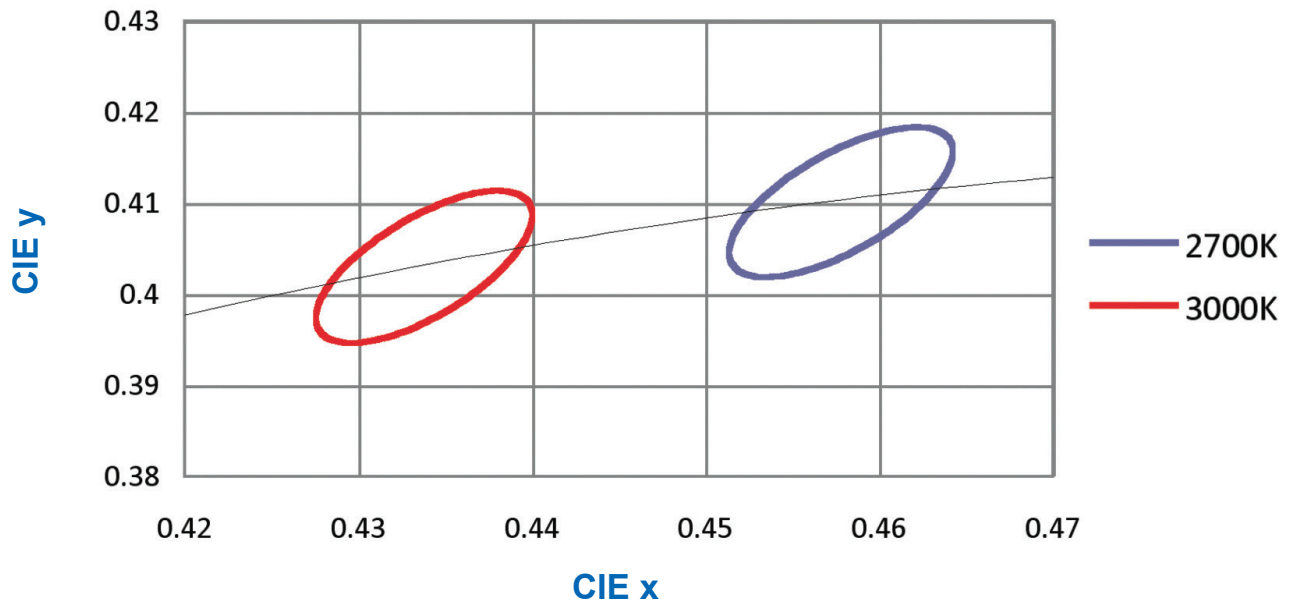

ChromaLit Binning Diagram, Cool White

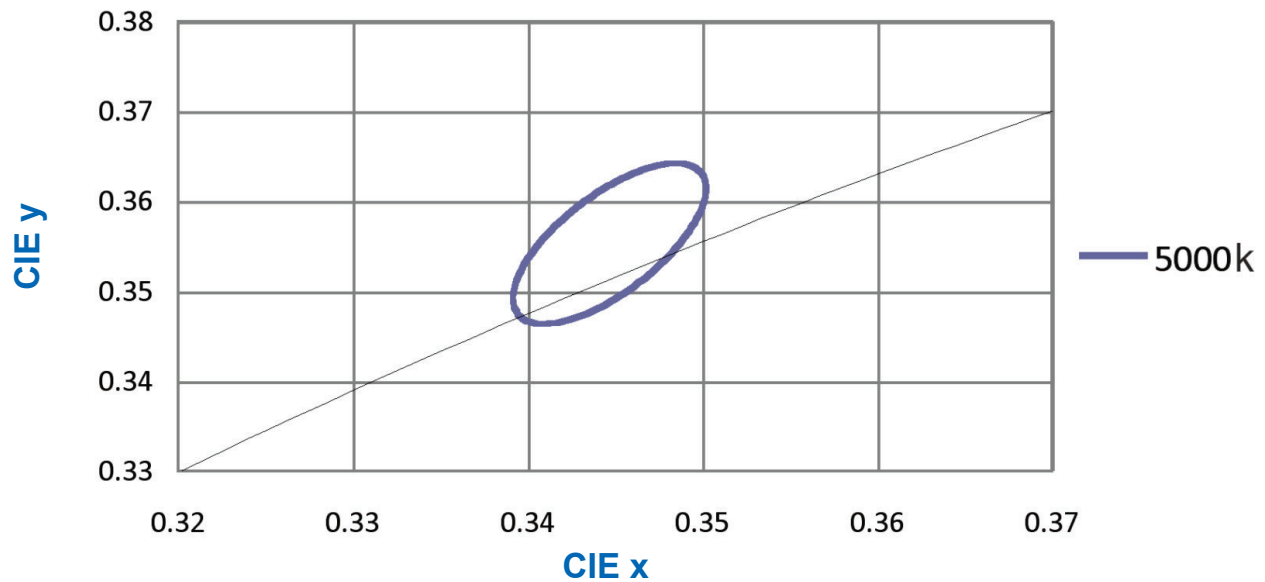

ChromaLit Bin Coordinates

CCT (K)	x	y
2700	0.4578	0.4101
3000	0.4338	0.4030
5000	0.3447	0.3553

Relative Spectral Power Distribution

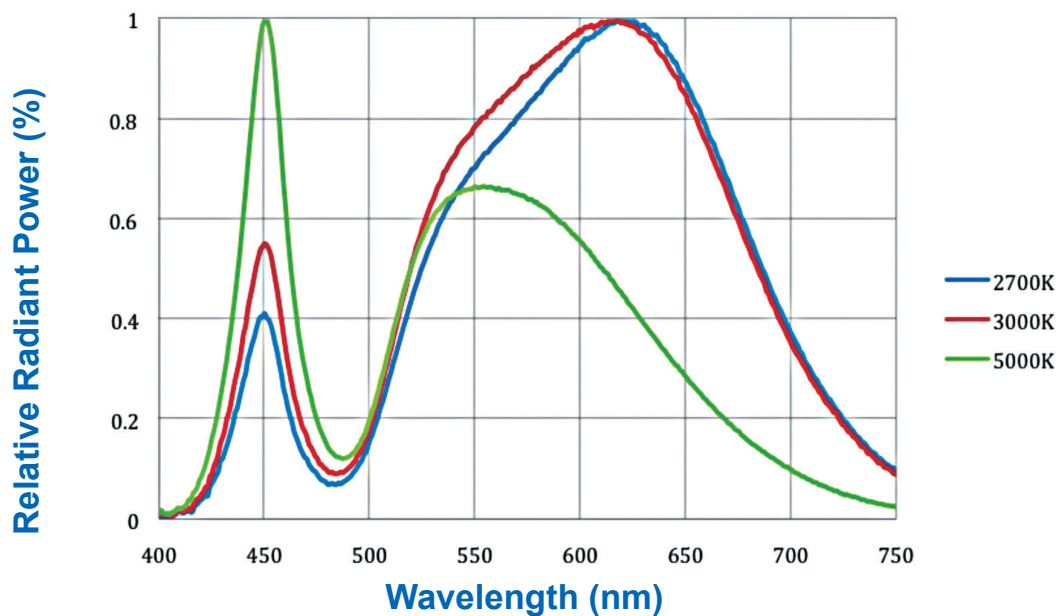

Intensity Distribution Diagram¹

Contour 75

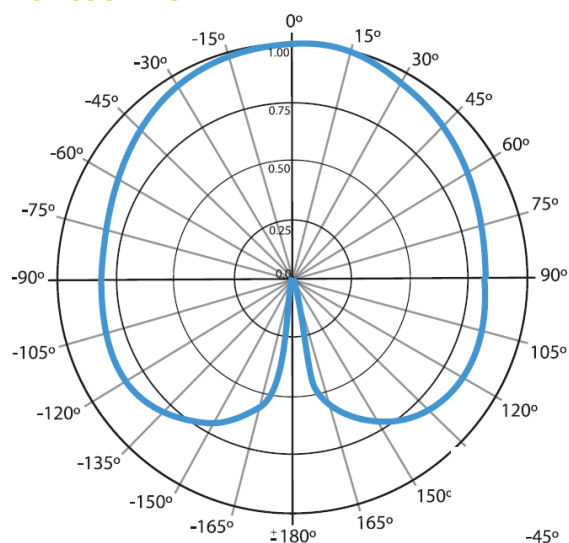

Contour 150

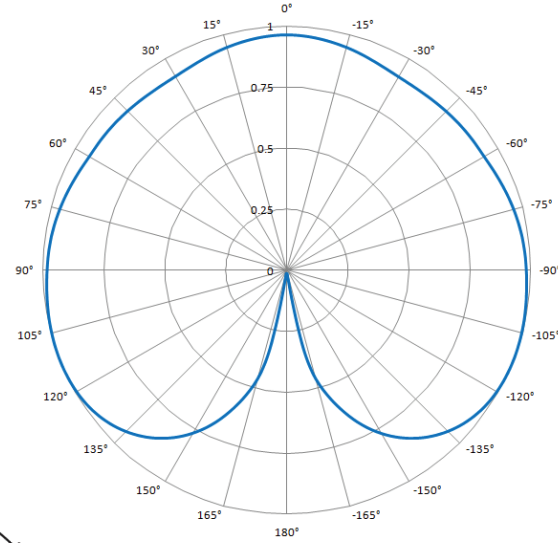

Contour 100

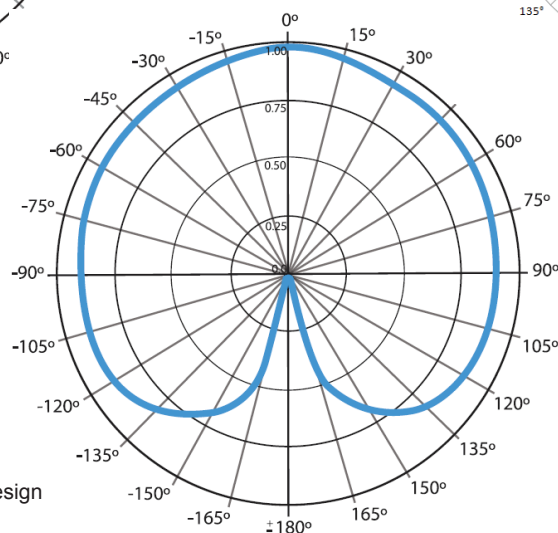

¹ Based on ChromaLit Contour 75 reference design

Performance Characteristics over Wavelength

Relative Conversion Efficacy over Wavelength¹

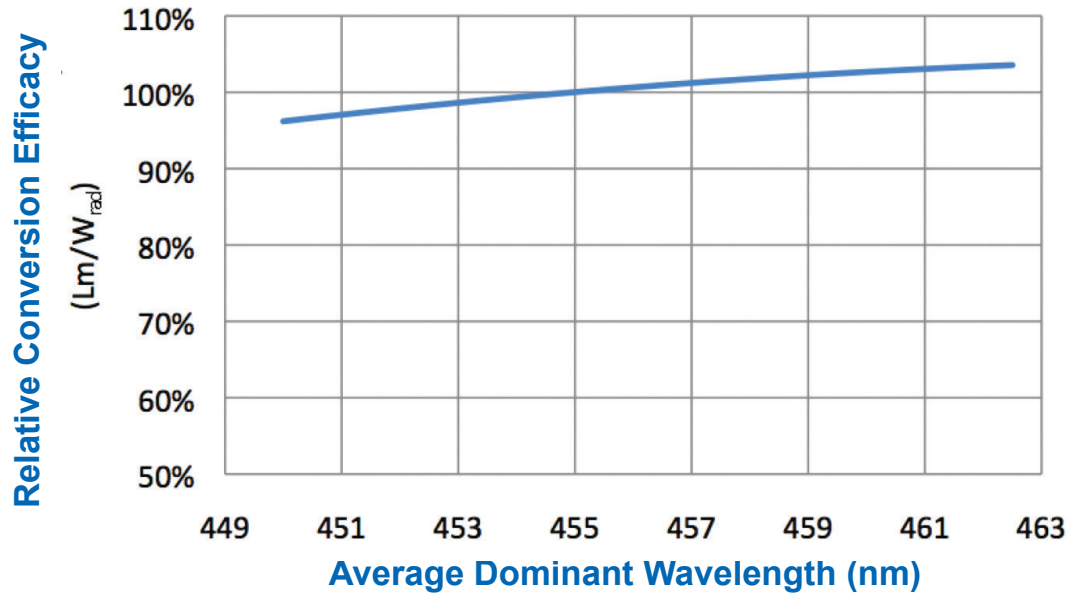

¹ Relative conversion efficacy does not reflect performance of blue LED over dominant wavelength.

Relative CIE Chromaticity Shift over Wavelength

	Average Dominant Wavelength				
	450nm	452.2nm	455nm	457.5nm	460nm
Δ CIE X Coordinate	-0.003	-0.002	0	0.001	0.001
Δ CIE Y Coordinate	-0.014	-0.007	0	0.005	0.008

Performance Characteristics over Temperature

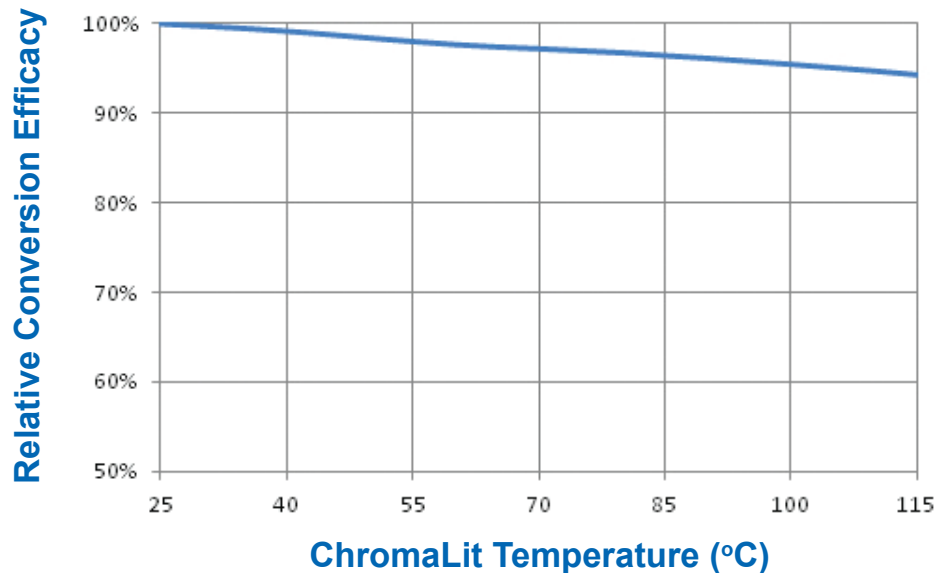

Absolute Maximum Ratings

Description	Maximum Values
Maximum operating temperature (Tmax ¹)	90°C
Minimum operating temperature	-40°C
Max storage temperature	90°C
Minimum storage temperature	-40°C
Response time to full light output	<10µs

¹ Tmax is the maximum temperature measured on the inner surface of ChromaLit. Please consult application guide for additional information on measurement location.

Mechanical Characteristics for ChromaLit

Material Properties

Description	Properties
Substrate Material	Polycarbonate
Coefficient of Thermal Expansion	70 ppm/°C

Overall Mechanical Dimensions

Dimension Designation	Typical Lumen Output (lm) ¹	Maximum Diameter (mm/in) ²	Maximum Height (mm/in) ²	Thickness (mm/in) ²
CTR75	1100	60.0/2.4	20.0/0.8	1.0/0.04
CTR100	1600	60.0/2.4	27.3/1.1	1.0/0.04
CTR150	2600	76.0/2.9	31.0/1.2	1.5/0.05

¹ Typical lumen output is estimated based on 2700K, 80CRI and typical blue LED radiometric watts recommended.

² Typical dimension tolerances are typically ±0.1mm.

Contour 75 Mechanical Diagram

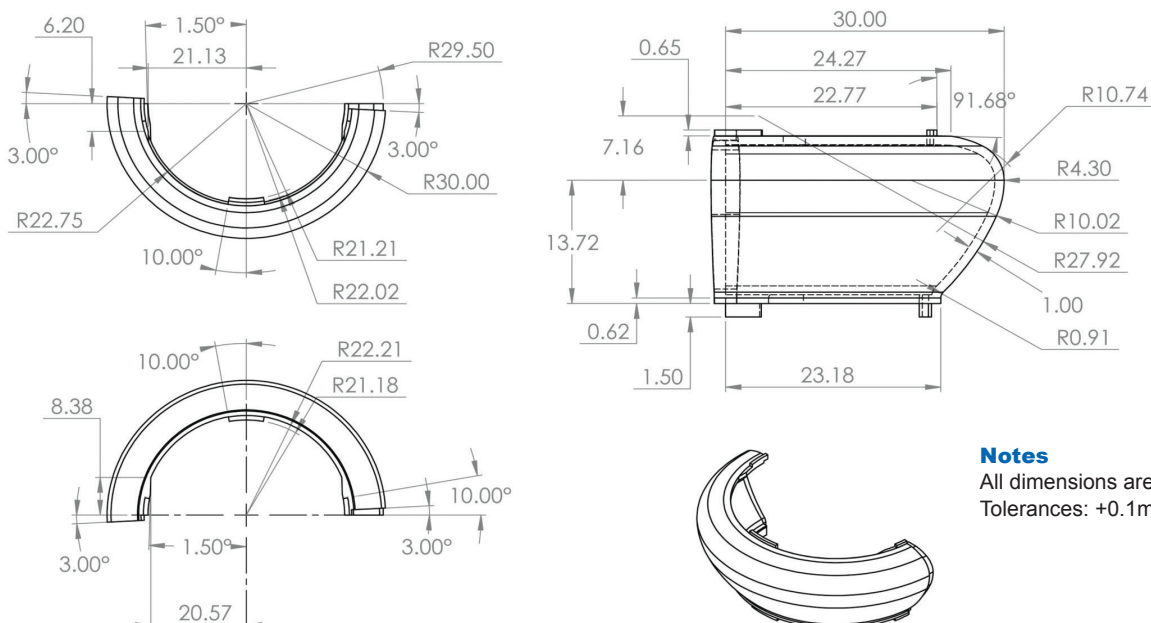

Notes

All dimensions are in millimeters
Tolerances: +0.1mm

Contour 100 Mechanical Diagram

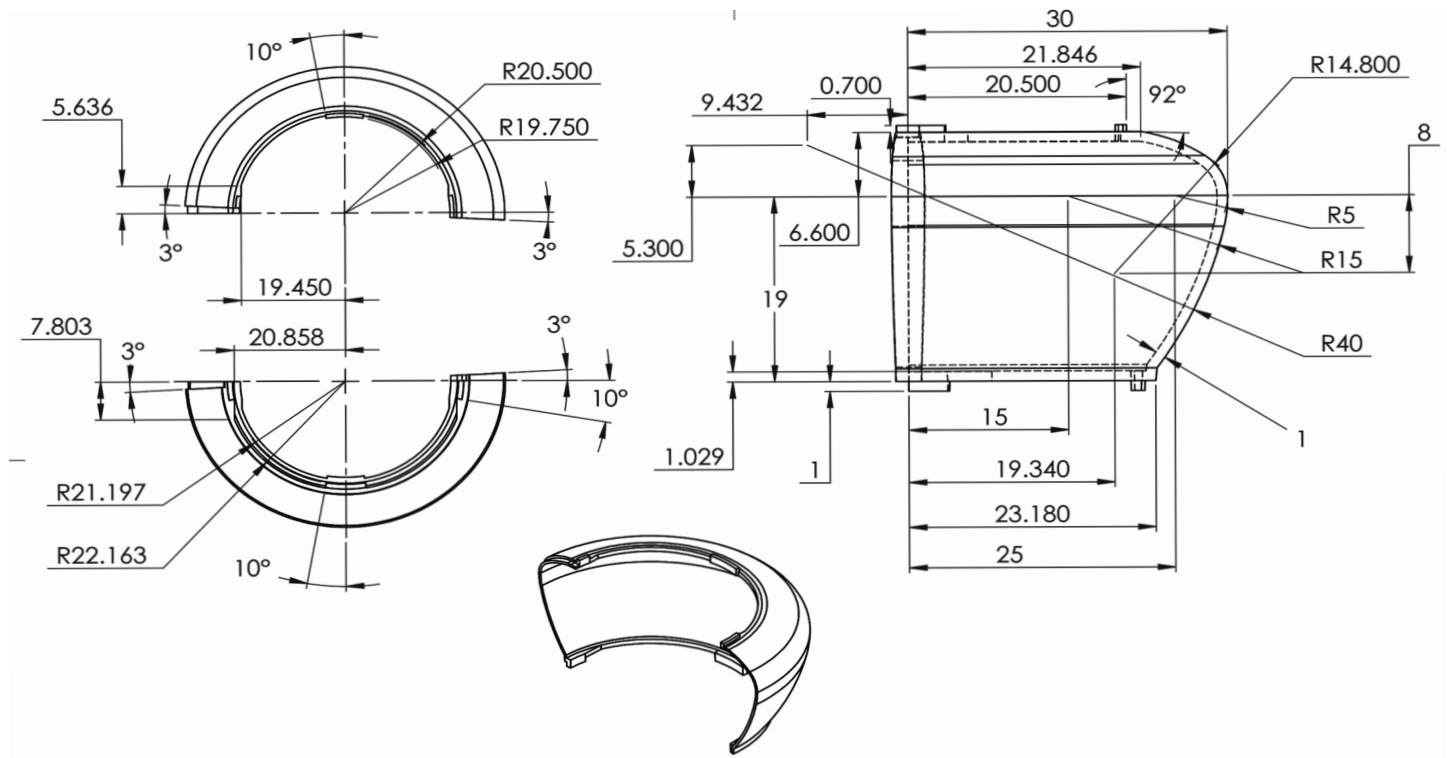

Notes

All dimensions are in millimeters
Tolerances: +0.1mm

Contour 150 Mechanical Diagram

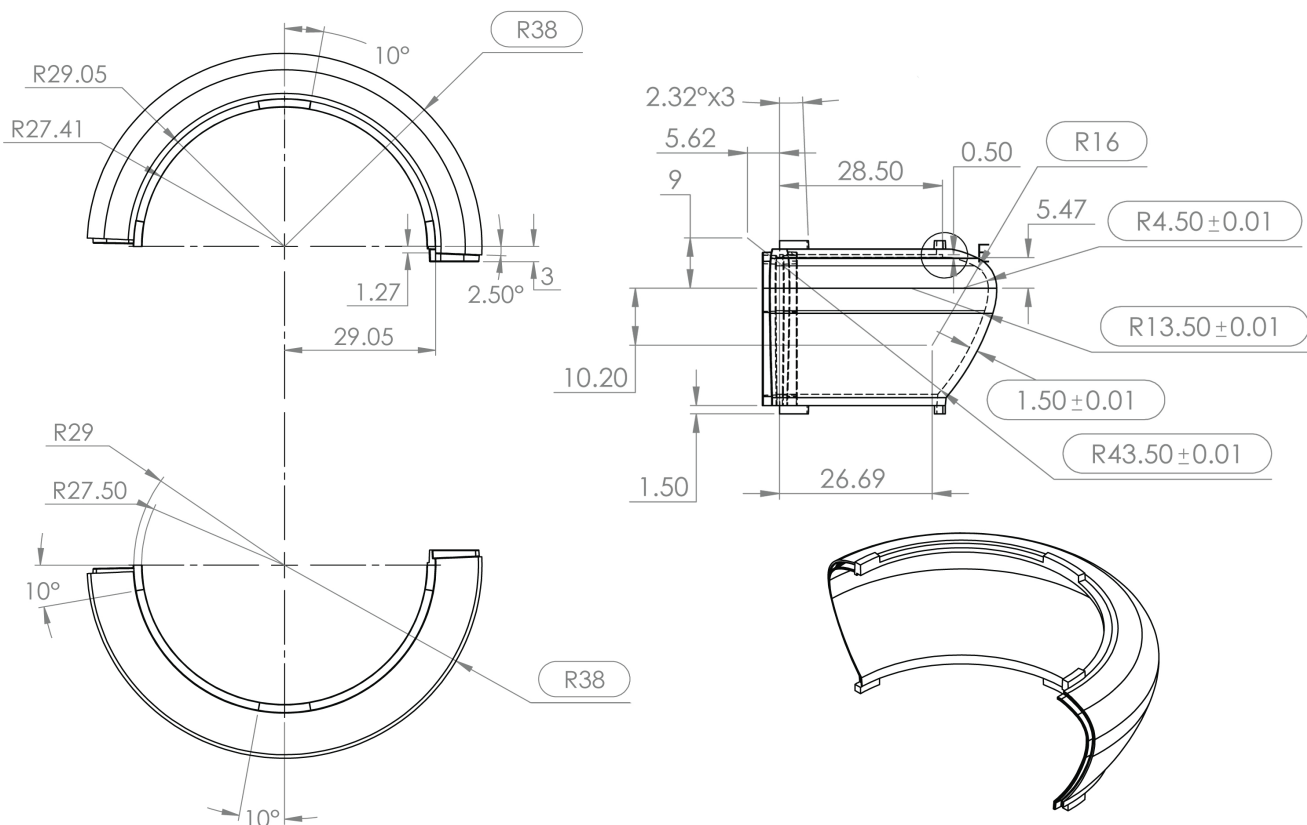



Handling Considerations

As a dirty or damaged phosphor layer could result in alteration in product performance, ChromaLit light sources should be handled similarly to most optical components. It is best to handle the parts at the edges and prevent mechanical abrasion. If adhesives are used, they must be kept off of the entrance or exit apertures of ChromaLit, since they could greatly impact performance. If parts require cleaning, use a lint free tissue, isopropanol (IPA), or mild detergent. Dry using compressed air.

Contact your Intematix representative for additional information on ChromaLit Contour A-lamp Reference Designs.

About Intematix

Intematix develops essential materials to drive the LED lighting revolution. The company's comprehensive range of phosphors and remote phosphor components can be used to build the foundation for the world's LED lighting products and systems including general lighting, displays, automotive and many others. A broad product selection of phosphors for LED makers and ChromaLit remote phosphors for lighting system manufacturers accelerate time-to-market, improve light quality and efficacy and reduce costs. To learn more about the company, please visit www.intematix.com.

INTEMATIX

46430 Fremont Boulevard ● Fremont, CA 94538

Tel: +1 510.933.3300 ● Fax: +1 510.668.0793

chromalit@intematix.com

www.intematix.com/ChromaLitContour