

InterfaceMasters
◀ INCORPORATED ▶

Niagara 2265

*PCI Express **Dual** Gigabit Copper Ports, with Bypass*

Niagara 2265 is designed with a built-in programmable bypass circuit to provide maximum up time for the network. The Bypass circuit takes the Niagara 2265 ports off line in case of either power or software failure. The bypass circuit works in absence of power.

Niagara 2265 Gigabit Ethernet Server Adapters is built on Intel's Gigabit technology and Interface Masters' sterling design and customer service.

Niagara 2265 is optimized to support x4 PCI Express bus at speeds of up to 2.5 Gb/s per PCI express lane.

Features

- Intel's 82571EB controller
- Peak bandwidth 2.5 Gb/s in each direction per PCI Express lane
- Programmable "Close" or "Open" while in the power off state.
- Programmable independent mode to function as dual Giga bit fiber card
- Two integrated PHYs for 10/100/1000 Mb/s full- and half-duplex operation
- IEEE 802.3ab, 802.3u, 802.3x compliant
- Host offloading – TCP/IP/UDP checksum, TCP segmentation and advanced packet filtering
- Two RJ45 Connectors

Dimension:

Length, 130 mm

Height, 65 mm

How to reach us

Interface Masters, Inc.

2381 Zanker Road, Suite 130, San Jose, CA 95131

Phone: 408-456-2545 x10

Fax: 815-364-0888

E-mail: info@interfacemasters.com

Home page: <http://www.interfacemasters.com>

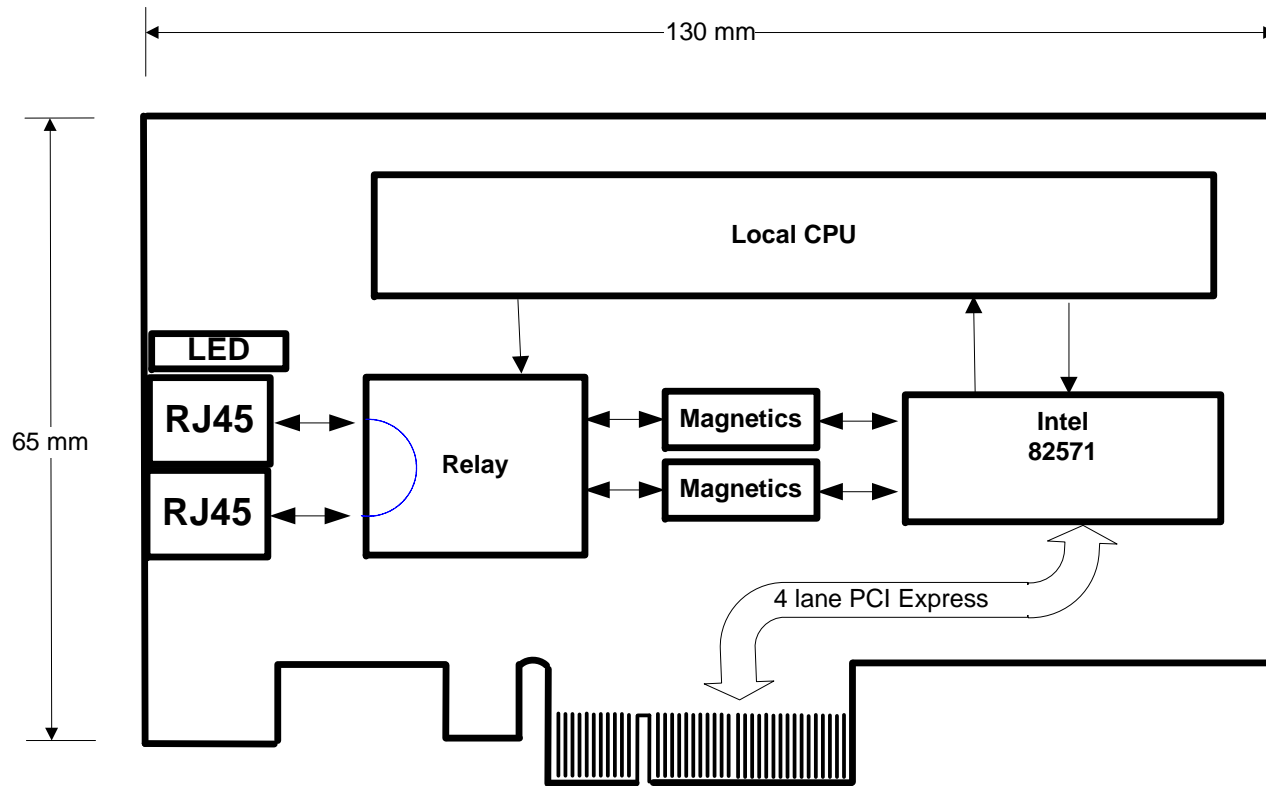

Figure 1 Block Diagram

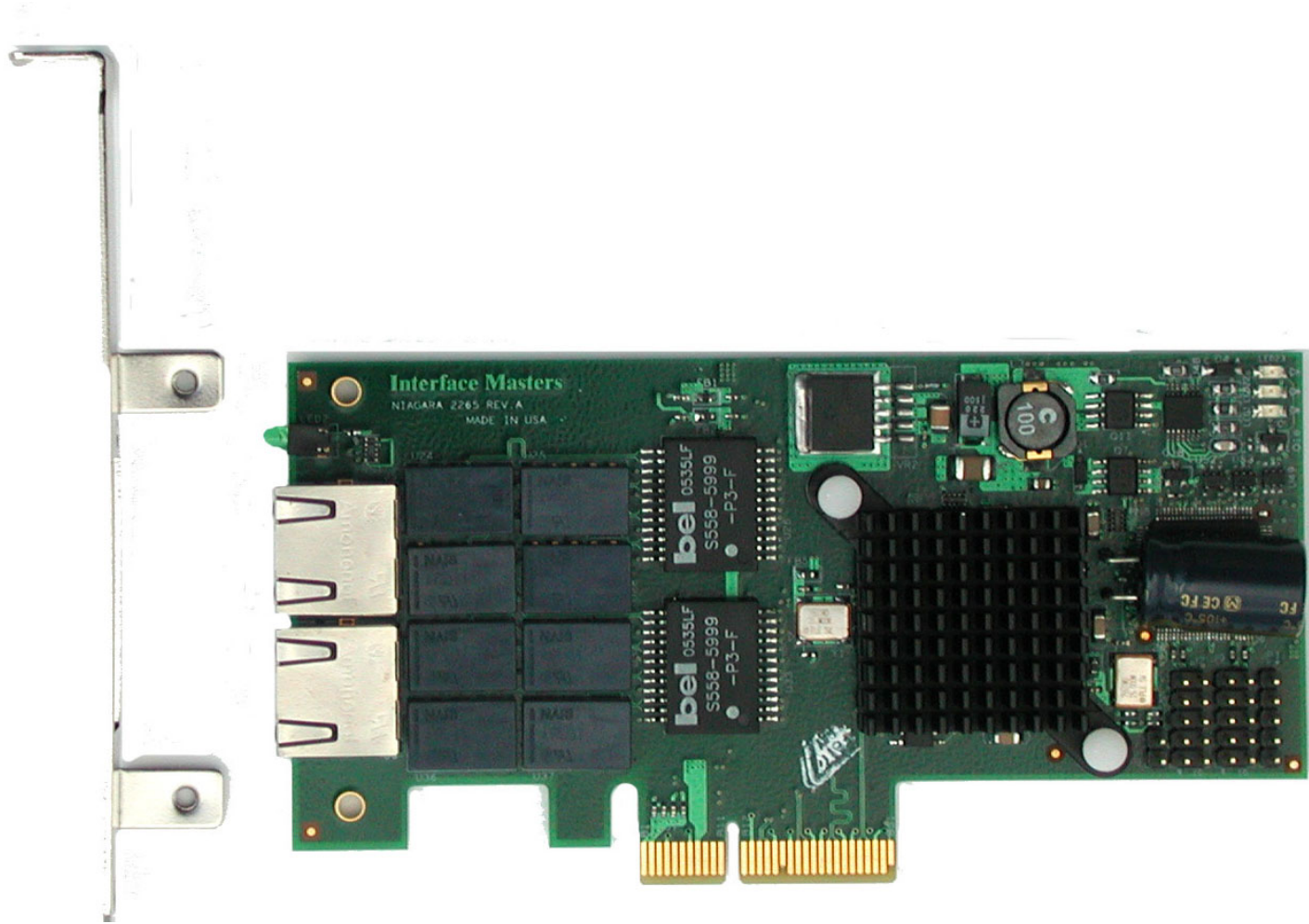

Figure 2, Fully assembled board