



Niagara 2262

PCI-X Quad Gigabit Copper Ports, with Bypass

Niagara 2262 is designed with a built-in programmable bypass circuit to provide maximum up time for the network. The Bypass circuit takes the Niagara 2262 ports off line in case of either power or software failure. The bypass circuit works in absence of power.

Niagara 2262 is designed for maximum system flexibility by providing a set of timers & registers for the upper two ports and another set for the lower two ports. The mode of operation for upper two ports is independent of lower two ports.

Niagara 2262 Gigabit Ethernet Server Adapters is built on Intel's Gigabit technology and Interface Masters' sterling design and customer service.

Niagara 2262 is optimized to support 64-bit/133MHz PCI-X bus based systems.

Features

- Intel's 82546GB controller
- Programmable "Close" or "Open" while in the power off state.
- Programmable independent mode to function as dual Giga bit fiber card
- Two integrated PHYs for 10/100/1000 Mb/s full- and half-duplex operation
- PCI-X 1.0a compatible, 64-bit/133MHz
- IEEE 802.3ab, 802.3u, 802.3x compliant
- Host offloading – TCP/IP/UDP checksum, TCP segmentation and advanced packet filtering
- Four RJ45 Connectors

Dimension:

Length, 163.1 mm

Height, 104.57 mm

How to reach us

Interface Masters, Inc.

2381 Zanker Road, Suite 130, San Jose, CA 95131

Phone: 408-456-2545 x10

Fax: 815-364-0888

E-mail: info@interfacemasters.com

Home page: <http://www.interfacemasters.com>

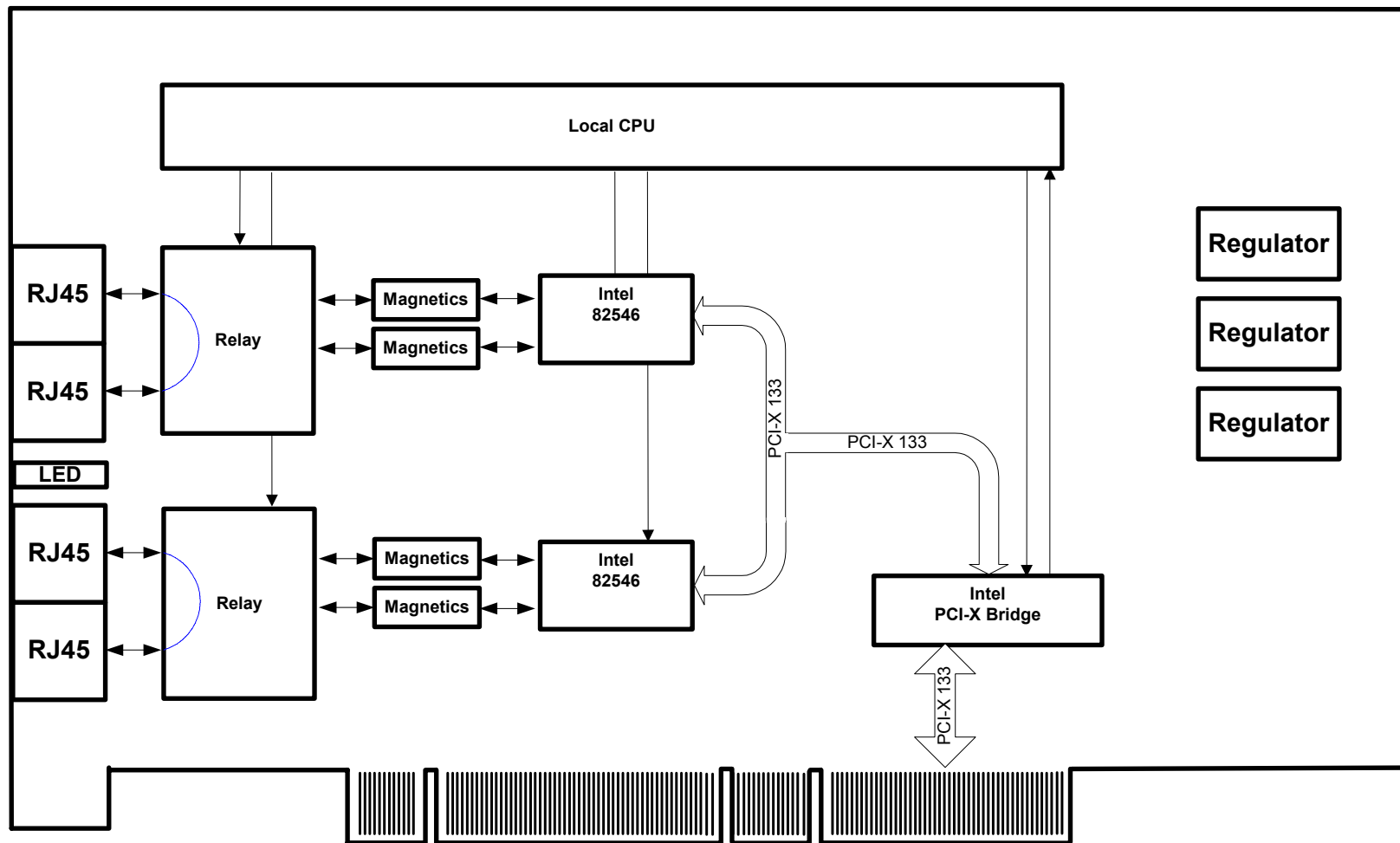

Figure 1 Block Diagram

