



www.intermountainelectronics.com
Email: iecomponents@ie-corp.com
Phone: (877) 544-2291 / (435) 637 7160

ARC CHOKER

Ground Wire Device (GWD)
P/N 1100-6010



1100-6010 Arc Choke

The 1100-6010 Ground Wire Device (GWD) is a high-current coil-type GWD suitable for use with ground monitors such as the GMS-504DZ or GLT-AT500.

In normal operation, a coil GWD acts as an impedance separating grounds to prevent ground monitor problems caused by parallel grounding paths, and to prevent inter-machine arcing. However, if a ground fault occurs, the reactive coil will saturate, and thus effectively short-circuit the grounds together for safety.

The 1100-6010 is intended for NGR current limited power systems operating at 5000 VAC (or less), with up to 4-O ground conductors and appropriate Ground Fault Relay (GFR) protection.

Refer to ground monitor specifications to ensure compatibility with, and proper use of, this GWD.

Mechanical Details

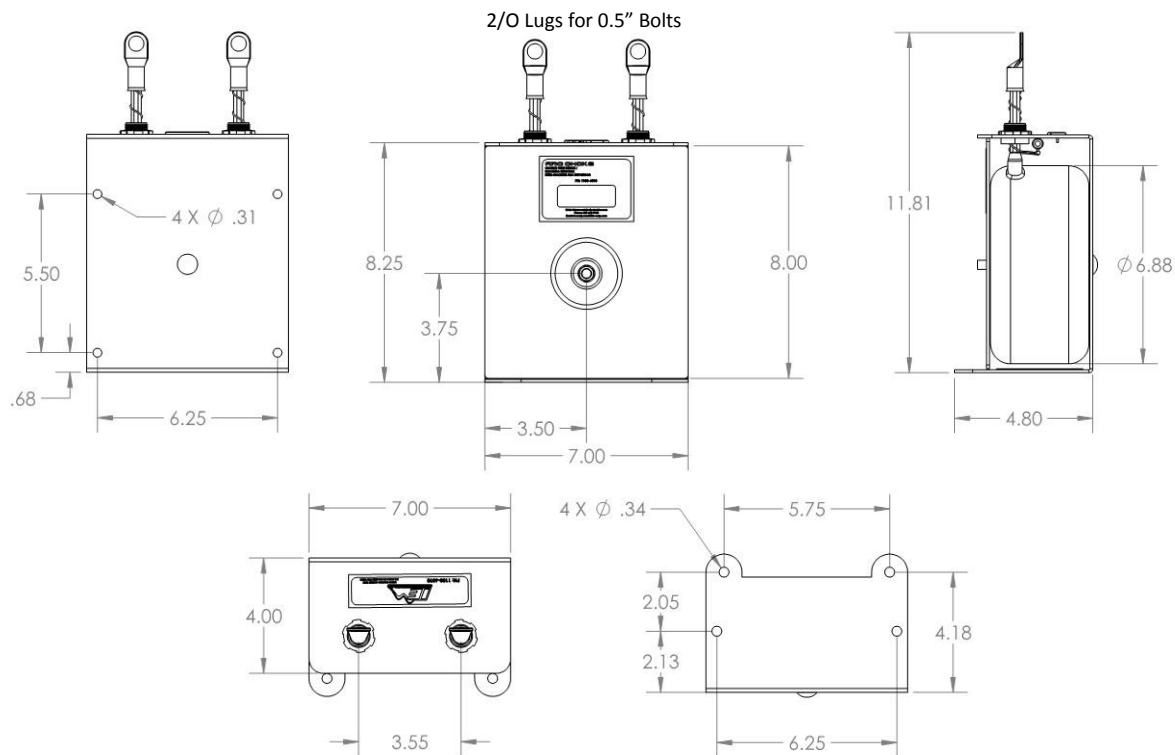

Weight: 18.4 lbs, 8.3 kg

Important Notice

This document contains information intended to aid in the proper installation and operation of the product described. Although this information will prove useful to the properly trained and qualified user, it is not practical to cover every possible situation, installation contingency, or other detail.

It is imperative that proper engineering and techniques are adhered to in the installation, operation, and maintenance of this product. It is the responsibility of the user to ensure that any system utilizing this product is safe, and that all personnel involved with the selection, installation, maintenance, and use of this product are properly qualified. This product must not be used in situations where its ratings are exceeded.

While every effort has been made to make sure the information in this document is accurate, IE cannot guarantee that there are no errors. Users of this product should verify any aspects of the product's design or performance that are critical to their application, and in particular, any aspects that may affect the safety of the overall system or installation.

Product design and specifications may change without notice.