

## **White Paper**

**What is so special about high temperature sensors?**

---

**Author: Jürgen Feustel,  
Head of the Technology Division**

## table of contents

<b>introduction</b>	3
<b>set up and operating mode</b>	4
<b>sensing range / Norm trimming plate</b>	5
<b>hysteresis</b>	5
<b>electronic prefabricated parts, coils and ferrites Printed circuit board materials and soldering techniques</b>	6
<b>mechanics and temperature drift</b>	7
<b>compound materials</b>	7
<b>unique properties</b>	8
<b>overview of the design with new features</b>	10
<b>design IB 08 / IB 08 compact design</b>	11
<b>design IB 09 (new)</b>	12
<b>design IB 13 (new)</b>	13
<b>design IB / IN 12/18/30/50 bis (150°C) 180°C</b>	14
<b>design IB / IN 30 up to 230°C</b>	15
<b>design IB / IN 50 up to 230°C</b>	16
<b>design IN 80</b>	17
<b>design IN 40 x 40 (new)</b>	18

## introduction

Inductive high temperature sensors are often indispensable where, in a manner of speaking, situations become 'heated', be it in the field of plastic injection molding, in foundries, in paint shops and similar applications. Here, they act as signal transducers for different control sequences, secure areas that are exposed to hazards or perform important control functions. But what makes high temperature sensors so special? Furthermore, what challenges have to be overcome when designing these 'specialists'?

When selecting a suitable high temperature sensor, it is essential to know the specific task that it is supposed to fulfill within a specific application and how high the maximum temperature compatibility of the device has to be for this. In connection with this, the installation situation and the necessary sensing range are decisive factors which influence the choice as to which inductive sensor is correct for a specific application.

For a provider such as ipf electronic which, among other things, also focuses on high temperature sensors, a large range of different solutions in all conceivable designs is particularly important. This way, users always receive the right devices for their applications. Variety is something 'nice', but it isn't everything. As such, in quite a few practical applications, users are able to benefit from the experience and the associated expertise that we have been able to gain as a specialist in the field of high temperature sensors.

## set up and operating mode

Put simply, inductive high temperature sensors consist of a coil (oscillator) directly behind the sensor head, followed by the evaluation electronics and an end stage and/or an amplifier. The oscillating coil behind the active surface of the proximity switch generates an alternating electromagnetic field. If an electrically conductive material finds its way into the field, turbulent flows are induced within it, which extract energy from the oscillating circuit. This ‘damping’ of the oscillator can be converted into a switch signal in an output amplifier (Fig. 1). Based on the functional principle, all metals are recorded, regardless of whether they move or not. Important note: The high frequency field does not generate any measurable heat or magnetic interference in the object which is to be recorded. As such, the sensors work without system interaction.

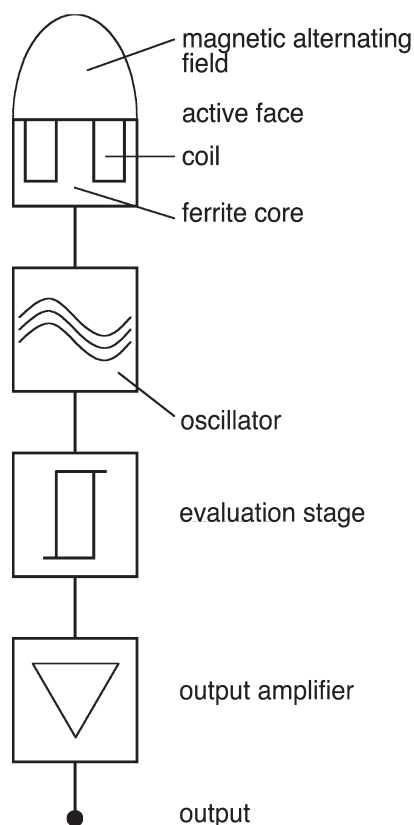

Fig. 1: functional principle of an inductive proximity switch

## sensing range / norm trimming plate

The distance to the sensor surface, where a metal causes a change in the state, is called sensing range. This range is not the same for all metals. That is why a so-called correction factor has been specified for the respective metal, e.g. copper or aluminium. The nominal sensing range is determined by a norm trimming plate. The plate is square, 1mm thick and fabricated out of steel (St37).

One differentiates between the normal sensing range  $S_n$ , which is determined without consideration for manufacturing tolerances or external influences, and the operational sensing range  $S_o$ . The safe operational sensing range is between 0 and 81% of  $S_n$  ( $0 < S_o < 0.81 \times S_n$ ).

## hysteresis

During the approach and subsequent removal of the measuring plate from the initiator there will be a difference between switch-on point and switch-off point. This integrated hysteresis prevents the switching output from oscillating during mechanical vibrations.

Usually the hysteresis is between 3 to 15% of  $S_n$  (Fig. 2).

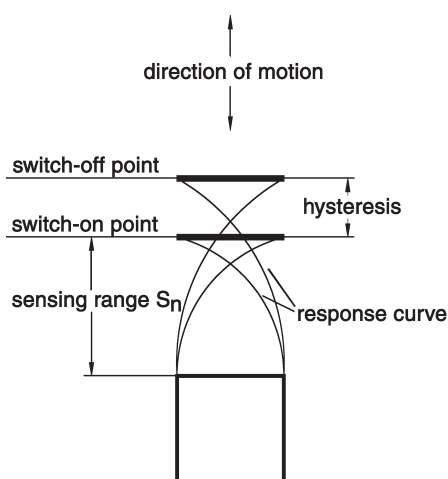

Fig. 2

## **electronic prefabricated parts, coils and ferrites**

At ipf electronic, when we refer to high temperature sensors, we generally mean inductive sensors for a temperature range in the order of +130 °C to +230 °C (max). In particular, upwards of +180 °C, quite a lot is demanded from the electronics in such devices. Above all, as a result of the flow of electrical current, each component heats itself to a certain extent. The loss of power in these types of components (which especially occurs as a result of the flow of heat due to the difference between the recorded output and the desired power output) continues to fall with a rising ambient temperature, resulting ultimately in a loss of performance associated with components.

For this reason, when it comes to the selection of electronic components which are suitable for a permanent temperatures of +200 °C (and over), such sensors are particularly important. However here, the opportunities are very limited, as around 99% of all electronic components are suitable for maximum working temperatures of up to +150 °C.

The same applies for the coil systems and the ferrites. Consequently, the coil wires that are available on the market are designed for a maximum permanent temperature of +130 °C. Only customized designs can be considered for applications above this temperature. Even the ferrite materials that are available for permanent temperatures of +200 °C and over are very limited. Accordingly, the challenges of a sensor provider which, in particular, also wants to offer solutions for an extremely high temperature range, lie in the task of identifying suitable components and materials in the market.

## **printed circuit board materials and soldering techniques**

This likewise affects the choice of suitable printed circuit board materials, wherein it is not only their high temperature resistance, but also their stretch in an x- and y-direction which plays a significant role. Otherwise, if the printed circuit board material that does not fit is stretched, the electronic components would be torn from the circuit board. As such, in the case of printed circuit boards which have to withstand a permanent temperature of +180°C and over, totally specific placement technologies have to be used, including, among others, special high temperature soldering.

However, in the case of printed circuit boards which have to resist a working temperature of up to +180°C, conventional, mechanical reflow soldering processes are used. Here, soft solder (solder paste)

is initially applied to a printed circuit board, either by means of template pressure, a dispenser, through preshaped filters as well as using electro-plating. Following this, the printed circuit board is assembled using the electronic components. As the solder paste has a sticky consistency, the components stick to the paste during the assembly process and don't have to be stuck on especially. When subsequently fusing the lead free solder, the assembled components center as a result of the surface voltage on the so-called landing pads and after that, break away. However, here as well, in the case of printed circuit boards for a working temperature of +230 °C, only special solutions can be considered.

## **mechanics and temperature drift**

Besides extreme permanent heat, inductive high temperature sensors must also be able to withstand high internal pressures. It is a basic physical law, that air expands when it is heated. As a result of the expansion of the hot air, pressure of around 1.3 bar can occur in a high density sensor. In view of such forces, the right mechanics are essential, especially in the case of silicone-free and high density sensors for temperatures up to +230 °C. This is one reason why, in the case of the silicone-free sensor designs IB/IN 30 (M30 x 1.5) from ipf electronic, the housing flaps which up until now, have been fixed using a bonded joint, are now securely fixed using a thread. Furthermore, the IB/IN 50 (M50 x 1.5) design is now available as an extremely dense version (comparable with IP protection class 68).

In addition, as each component of a sensor changes its technical characteristics due to the impact of temperature, with a view towards the correct temperature drift, the biggest challenge is to size the sensor switch in such a way that all changes relating to the components do not lead to a change in the sensor overall.

## **compound materials**

In connection with the mechanical design of a high temperature sensor, the 'silicone-free' characteristic has already been mentioned. However most of the 'soft' compound materials for electronics which are available for a permanent working temperature of over +180 °C contain silicone.

Even with a view towards high processing security, manufacturers and the operators of paint shops especially insist on silicone-free high temperature sensors. This is because the gas emissions from silicone (degassing) can cause a problem in high temperature environments. An example for this, is the use of inductive sensors in electrophoretic dip painting plants. Electrophoretic dip painting has long been a tried and tested process for coating vehicle parts against corrosion. Here, inductive high temperature sensors are used in enameling furnaces for requesting information about positions, i.e. of lifting devices, following electrophoretic dip painting. If one were to use silicone as a compound material for the sensor, this could degas. This degassing would spread in the vicinity of the plant and, in the worst case, fall upon uncoated vehicle parts. This would result in faults associated with the coat.

## unique properties

This is why ipf electronic uses silicone-free sensors for these sorts of applications (or similar). These are based on a ceramic compound which enables the proximity switches to withstand temperatures of +230 °C (max.). One special feature of these devices, apart from the absence of silicone and the optional high density (comparable with IP 68) is the special design (Fig. 3).



Fig. 3: Proximity switches which withstand temperatures of +230 °C max. and have very special characteristics.



The particular challenge that is faced when correctly selecting components was described at the start of this article. Technically, at the moment, it is not possible to design devices for a temperature range up to +230°C in such a way that all the electronics can be fitted into a housing so that it can be deployed in the 'hot area'. This is why, as a general rule, such systems were designed in two parts, wherein the sensor head is located at the inquiry point and the evaluation unit is located in the cold area.

The crucial drawback with such solutions: The length of the line between the sensor head and the amplifier is preset and cannot be changed. In addition, the separation of the coil from the evaluation electronics has the disadvantage that the cable length has a negative effect on the achievable sensing range of the sensor.

This is not the case with ipf electronic's inductive sensors for working temperatures up to +230 °C. As a result of a special design of the two part sensor system, the cable length between the sensor head and the amplifier is fully and variably selectable. This is something which crucially increases the flexibility of these devices in the application. Even in the case of on-site installation, it is possible to adjust the cable length where necessary, without any problems. Because the temperature resistant connection lead between the sensor head and the evaluation unit is equipped with pluggable connections, in the case of a defect, the components can be quickly exchanged on an individual basis. In the case of other solutions, the entire system has to be exchanged, and with it, this involves high costs.

## overview of the design with new features



The following pages provide a summary of the different high temperature sensor designs and new developments in this field.

## design IB 08 / short design IB 08

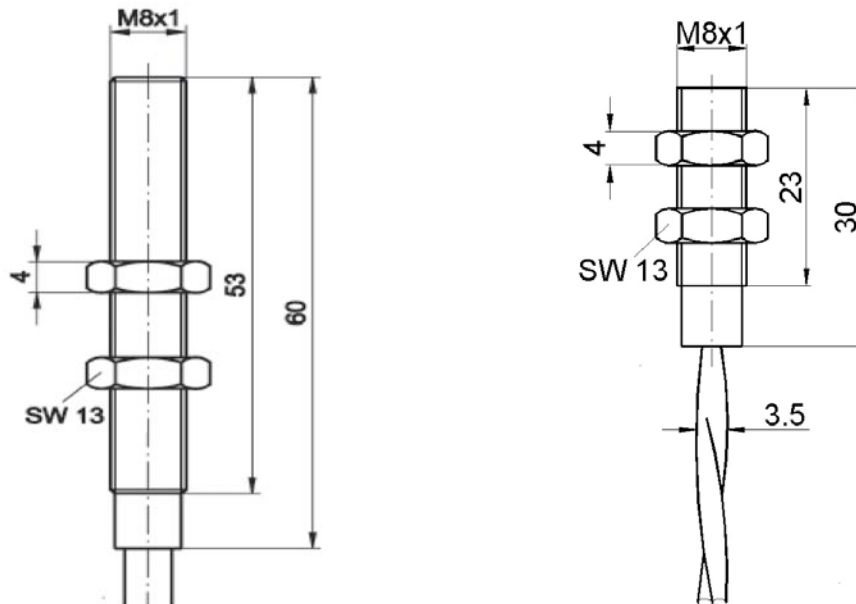

M8x1

length: 60mm and/or 30mm

Sn: 2mm

- temperature range up to 140°C
- with a silicone or teflon lead
- with M12-connector
- as a PNP normally open switch
- contains silicone (a silicone free version is being prepared)
- short design with an external amplifier

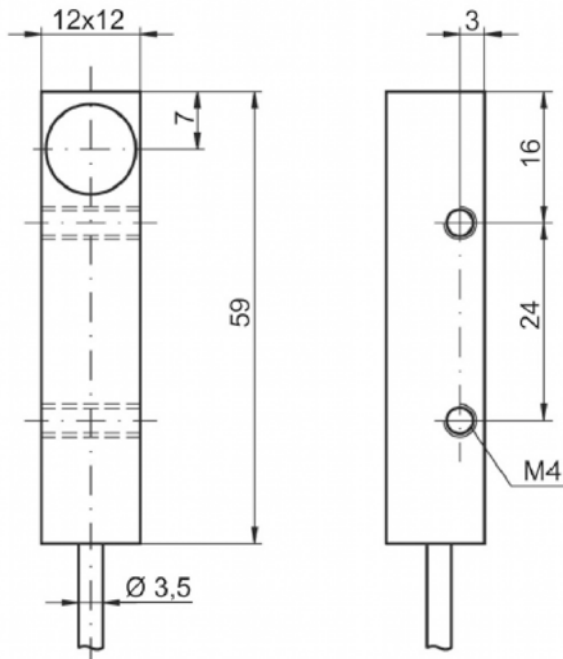
**design IB 09 (new)**

8x8mm

length: 55mm

SN: 2mm

10-30VDC / 80mA

- temperature range up to 140°C
- with a silicone lead
- as a PNP normally open switch
- contains silicone

## design IB 13 (new)

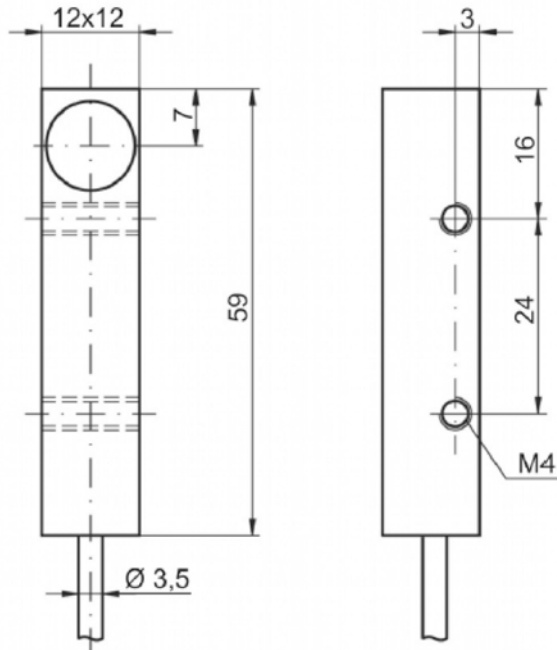

12x12mm

length: 59mm

Sn: 4mm

10-30VDC / 200mA

- temperature range up to 140°C
- with a silicone lead
- as a PNP normally open switch
- contains silicone

## design IB / IN 12/18/30/50 up to (150°C) 180°C

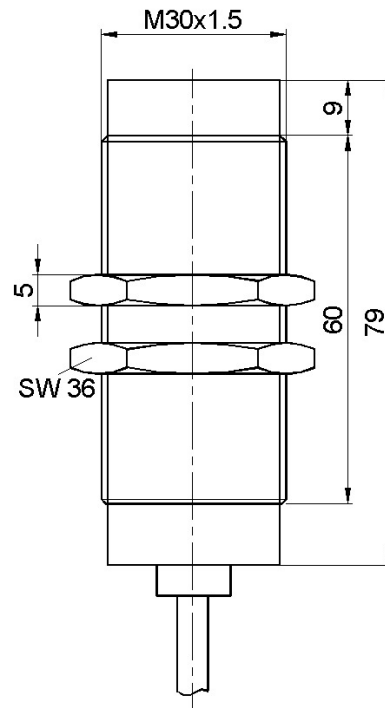
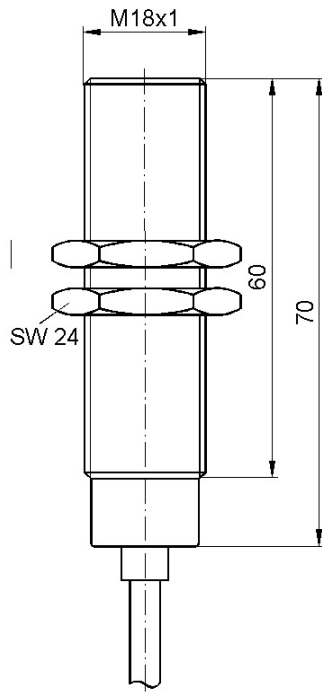

IB

M18x1.0

length: 70mm

Sn: 5mm

10-35VDC / 150mA

IN

M30x1.5

length: 79mm

Sn: 15mm

10-35VDC / 150mA

- temperature range up to (150°C) 180°C
- with LED (130°C)
- with a silicone or teflon lead
- with a M12 or LEMO-connector
- as a PNP normally closed switch / PNP normally open switch
- as a PNP normally closed switch / PNP normally open switch (new)
- contains silicone (a silicone free version is being prepared)

## design IB / IN 30 up to 230°C

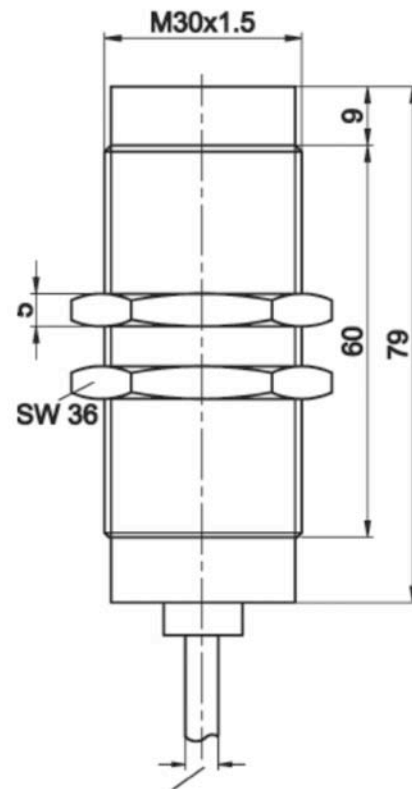
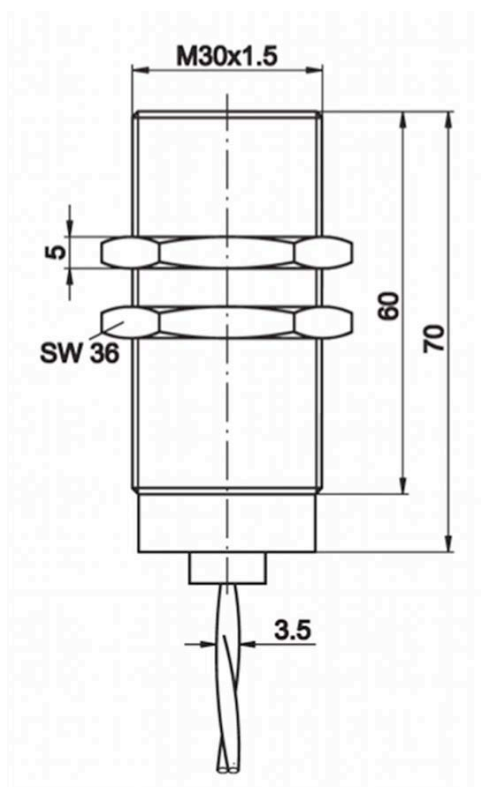

IB

M30x1.5

length: 70mm

Sn: 10mm

IN

M30x1.5

length: 79mm

Sn: 15mm

- temperature range up to 230°C
- Connection to an external amplifier
- with teflonline or LEMO-connector
- completely revised design (new)
- silicone free (new)
- can also be implemented as a short design

## design IB / IN 50 up to 230°C

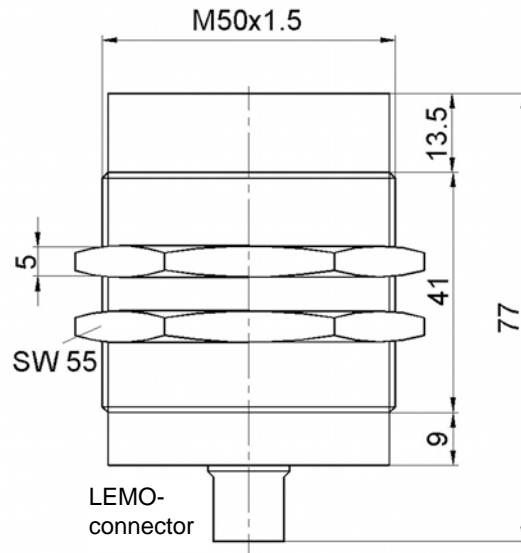
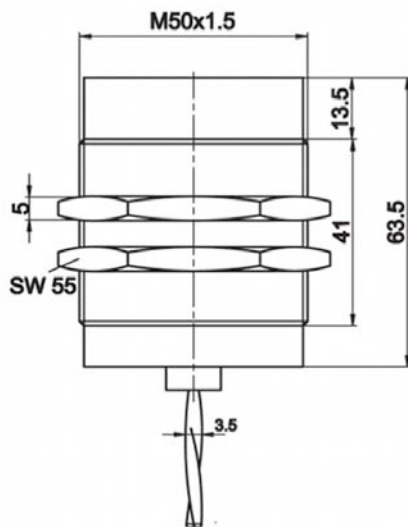

IB

M50x1.5

length: 50mm

Sn: 20mm

IN

M50x1.5

length: 77mm

Sn: 25mm

- temperature range up to 230°C
- connection to an external amplifier
- with teflonline or LEMO-connector
- completely revised design (new)
- silicone free (new)
- also available as a dense version, comparable with IP68

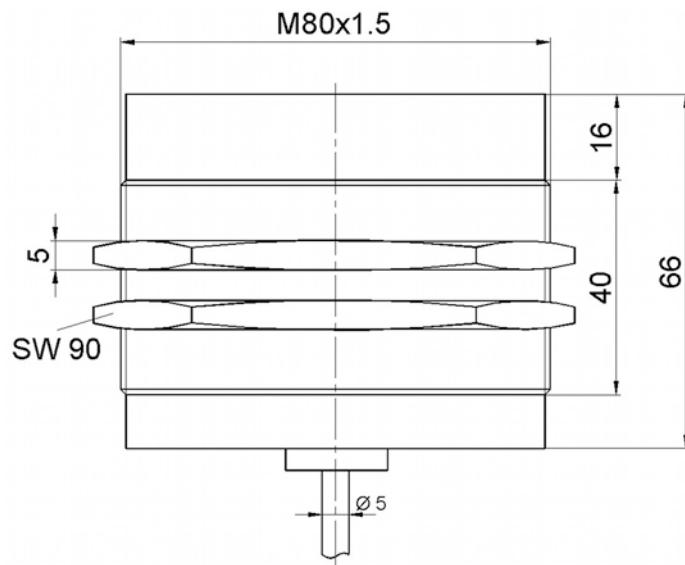

**design IN 80**

M80x1.5

length: 66mm

Sn: 25mm

10-35VDC / 200mA

- temperature range up to 160°C
- with teflonline or LEMO-connector
- as a PNP normally closed switch / PNP normally open switch
- contains silicone

## design IN 40 x 40 (new)



IN40012W



IN406040

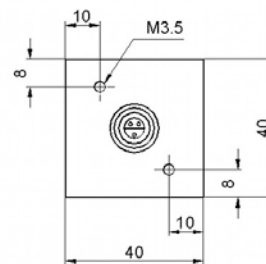
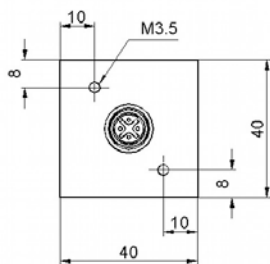
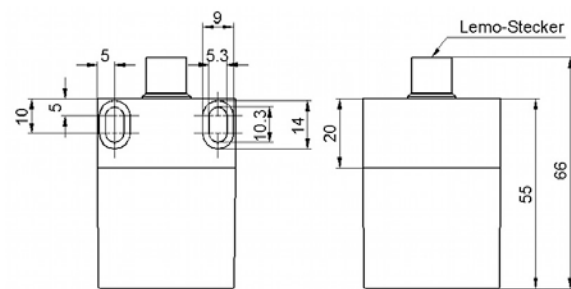
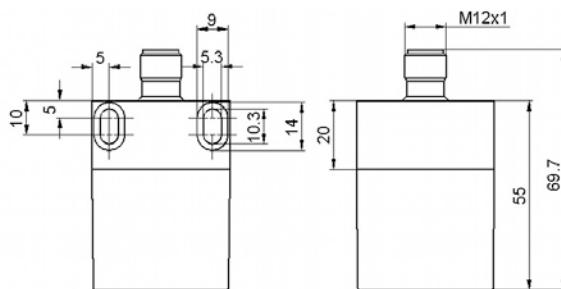

Sn: 20mm

- up to 150°C, with an internal amplifier
- up to 230°C, with an external amplifier
- connection to an external amplifier (pluggable)
- with M12 or LEMO-connector
- completely new design (new)
- silicone free (new)

White Paper: What is so special about high temperature sensors?

---

---

This white paper is protected by copyright. The use of the text (even in the form of extracts) and the images in this document is only permitted with the written approval of ipf electronic gmbh. Subject to alteration.