GPS and Precision Timing Applications

Application Note 1272

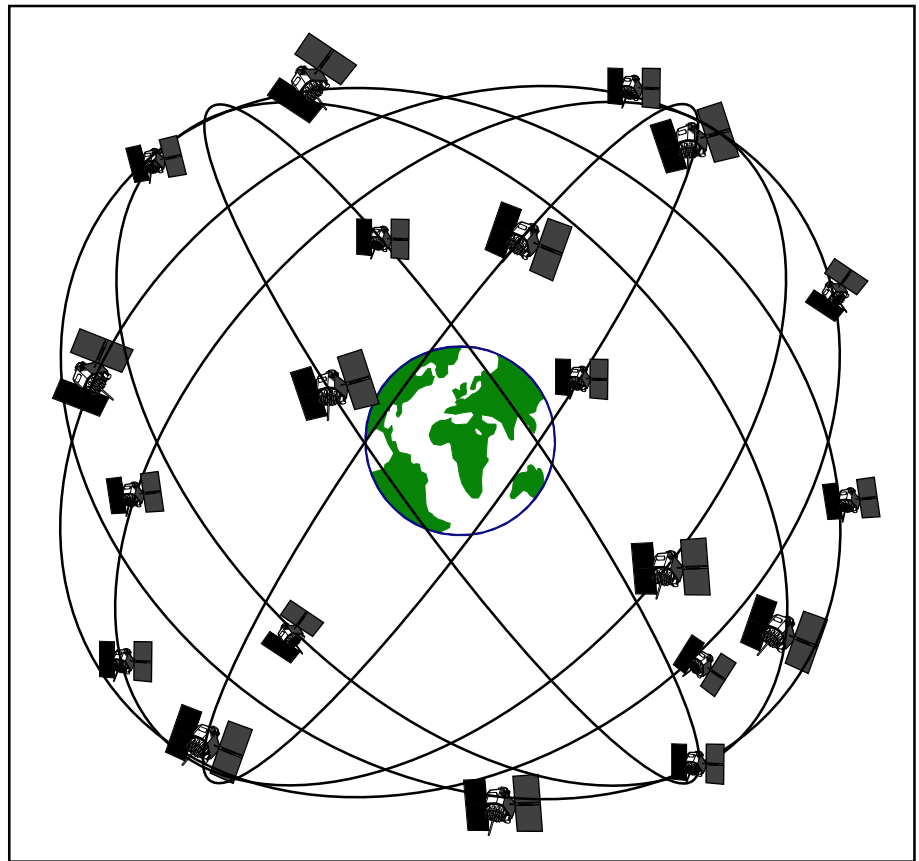

Table of Contents

	Page
An Introduction to GPS	4
GPS Structure, Control and Operation	6
The Theory of GPS Operation	8
GPS Nonmilitary User Concerns	21
Hewlett-Packard GPS Synchronization Products and Applications	22
GPS Glossary	25
Abbreviations and Acronyms	26

An Introduction to GPS

For thousands of years adventurers, high priests, kings, emperors, explorers, sailors and other privileged folk have found their way from place to place, predicted the future, furthered religions and developed entire cultures, in part, by looking to the stars. Mankind has grouped the stars into constellations to aid recognition and to measure the change of seasons. Using the stars as a measure of place and time is a very old science. History tells us that study of the heavens was developed independently by a number of civilizations widely scattered on the earth. Even today, a prudent navigator will not leave a seaport without a sextant and the compiled tables and knowledge needed to find the way in the event of a disaster.

December of 1993 marked the debut of a full constellation of manmade stars (or satellites) orbiting the earth and transmitting the data needed for determining precise time and position. Today's traveler, astronomer, air traffic controller, delivery fleet manager, surveyor, map maker, aviator or sailor can attain position and time information with a stability, accuracy and reliability unheard of just a few years ago.

It is now possible to obtain precise timing information anywhere on earth with high reliability and at a low cost. It is even possible to synchronize the timing of geographically dispersed systems. This enables important applications in wireless and wired communication systems.

Hewlett-Packard has a broad range of products which use precise time to improve the performance and reliability of communication systems, power distribution systems and telecommunication systems. For more information, see page 22.

The NAVSTAR Global Positioning System

We're referring to a manmade constellation called the NAVSTAR Global Positioning System (GPS), a space-based radio positioning utility. GPS provides accurate three-dimensional position (latitude, longitude, and altitude), velocity and precise time traceable to Coordinated Universal Time (UTC). All this information

is continuously available worldwide to anyone with a GPS antenna and receiver. It is usable in all weather conditions, anywhere on or near the earth (on the ground, at sea, in the air, and in near space). No user fees are either charged or anticipated. As a result, international civil use of the Global Positioning System is widespread and growing rapidly.

The U.S. Department of Defense (DoD) developed GPS over a period of almost 20 years at a cost of more than \$10 billion. GPS is intended to serve as the basis of the U.S. DoD's primary means of radio navigation well into the twenty-first century.



**GPS Delta
VLV Launch
(USAF photo)**

Also, in accordance with the Federal Radionavigation Plan (FRP) prepared by the U.S. DoD and U.S. Department of Transportation (DOT):

“...many existing navigation systems are under consideration for replacement by GPS beginning in the mid to late 1990s. GPS may ultimately supplant less accurate systems such as LORAN-C, Omega, VOR, DME, TACAN, and Transit, thereby substantially reducing federal maintenance and operating costs associated with these current radio navigation systems.”

GPS is more than a military aid to navigation. Civil applications abound and outnumber military uses in terms of the range of applications, number of users and total market value. New commercial applications arise rapidly as the decreasing cost, size and power consumption of GPS receivers alter the economics of implementing GPS. Meanwhile, receiver capabilities continue to improve at a pace that rivals the rate of change in microprocessors. Small multi-channel receivers with sophisticated tracking, filtering and diagnostic features are making possible even more advanced applications.

Among the already well established civil uses of GPS are marine and aviation navigation, precision timekeeping, surveying, fleet management (rental cars, taxis, delivery vehicles), aircraft approach assistance, geographic information systems (GIS), wildlife management, natural resource location, disaster management, meteorologic studies and recreation (hiking and boating) to name

a few. GPS will change the way many people do their work. It will fundamentally alter many existing industries and provide opportunities for new industries we have not yet imagined.

GPS as a Source of Precise Time, Time Interval and Frequency

Most descriptions of GPS focus on its use as a system to provide precise latitude, longitude and altitude information. Often it is used to determine speed as well. GPS is depicted as a dynamic positioning system which provides the raw information needed to navigate, that is, to find where we are and to figure how to get from there to some desired place (or, perhaps, to avoid some undesired place). This is a fundamental use for GPS but it is far from the only use of the system.

We live in a four-dimensional world and the fourth dimension is time. Without an accurate estimate of time, finding position as it is understood today is not possible. The GPS delivers time, time interval and frequency anywhere in the world with precision and accuracy more than adequate for many applications.

With GPS timing, precision of billionths of a second is now possible. A billionth of a second is called a nanosecond (ns). Such precision has opened up all kinds of opportunities.

Continuous access to precise time and frequency, at low cost and anywhere it is needed, is a revolutionary development. It allows, for example, improved synchronization and timing of both wired and wireless communications systems. Users see higher quality (fewer dropped calls), increased capacity (no delays getting on), improved data transmission (low error rates) and new services (lifetime phone number).

Or, consider timing electrical transients arriving at substations in a geographically dispersed power delivery system. A fault (a downed line, for instance) can be precisely located and crews can be transported to the precise geographic spot without delay. Similar statements can be made for wide-area computer networks.

GPS allows precise transfer of time between the world's timing centers ensuring we all tick on the same clock. The tracking of deep space vehicles, timing requirements of astronomical labs (such as millisecond pulsars), military and intelligence uses of precise time — the list goes on. In general, wide availability of precise time and frequency at low cost will improve many scientific, manufacturing, business, R&D and just plain fun activities.

GPS Structure, Control and Operation — Or, how does this all work?

The Global Positioning System is divided into three segments. These segments have been defined by the U.S. DoD and might be thought of as independent. In practice, all segments work in a very integrated manner and none could exist without the others. The official names are the Space, Control, and User Segments. Figure 1 diagrams the relationship between segments.

The Space Segment consists of the satellite constellation — twenty-one active satellites and three in-orbit operating spares.

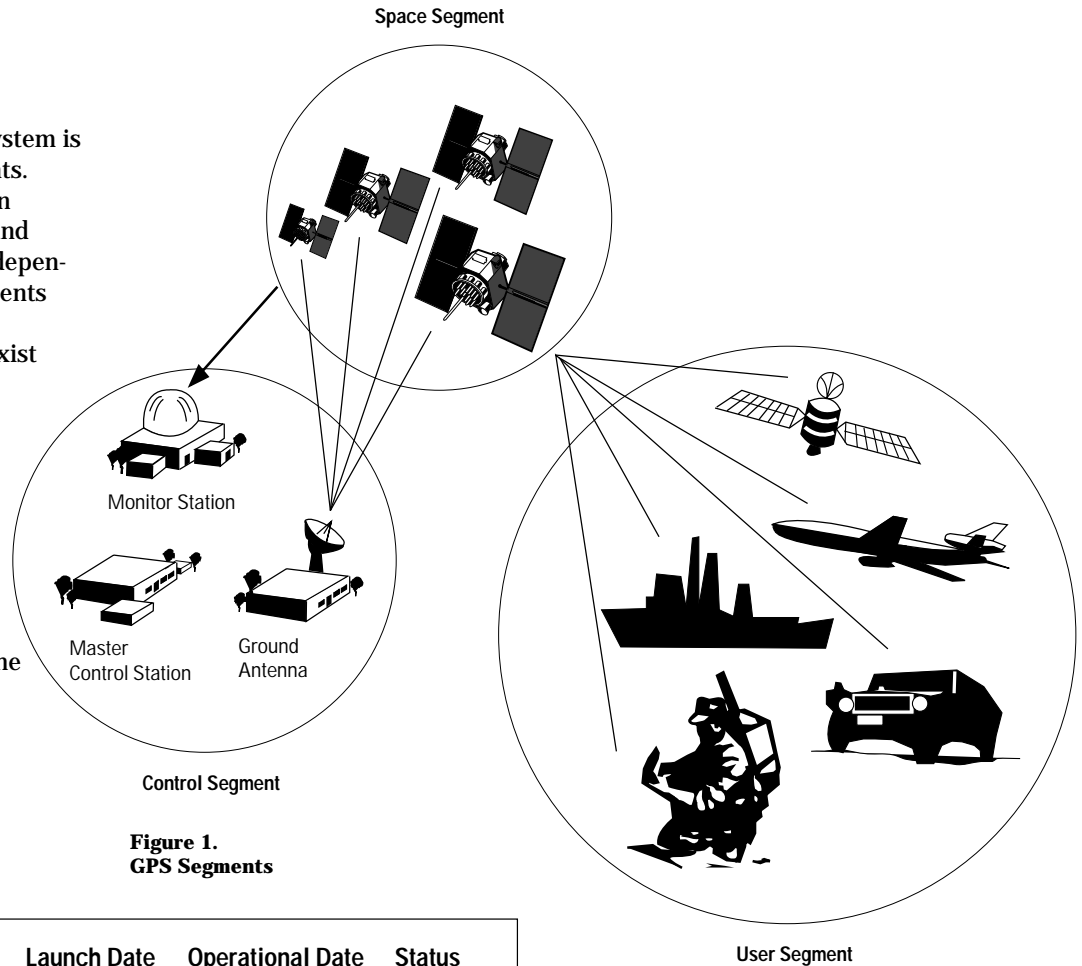

Figure 1.
GPS Segments

Block & NAVSTAR #	SVN	PRN	Launch Date	Operational Date	Status
II-1	14	14	02/14/89	04/14/89	operating
II-2	13	2	06/10/89	07/12/89	operating
II-3	16	16	08/17/89	09/13/89	operating
II-4	19	19	10/21/89	11/14/89	operating
II-5	17	17	12/11/89	01/11/90	operating
II-6	18	18	01/24/90	02/14/90	operating
II-7	20	20	03/25/90	04/19/90	operating
II-8	21	21	08/02/90	08/21/90	operating
II-9	15	15	10/01/90	10/20/90	operating
IIA-10	23	23	11/26/90	12/10/90	operating
IIA-11	24	24	07/03/91	08/30/91	operating
IIA-10	25	25	02/23/92	03/24/92	operating
IIA-10	26	26	04/10/92	04/25/92	operating
IIA-14	28	28	07/07/92	07/23/92	operating
IIA-15	26	26	09/09/92	09/30/92	operating
IIA-16	27	27	11/22/92	12/11/92	operating
IIA-17	32	1	12/18/92	01/05/93	operating
IIA-18	29	29	02/03/93	04/04/93	operating
IIA-19	22	22	03/30/93	04/13/93	operating
IIA-20	37	7	05/13/93	06/12/93	operating
IIA-21	39	9	06/26/93	07/20/93	operating
IIA-22	35	5	08/30/93	09/28/93	operating
IIA-23	34	4	10/26/93	11/22/93	operating
IIA-24	36	6	03/10/94	03/28/94	operating

NOTE: SVN refers to the satellite number and PRN indicates the satellite's pseudorandom noise code.

Satellite Constellation History

The U.S. Coast Guard provides the table, at left, of operational satellite launches (in date order): The Control Segment includes the Master Control Station (MCS), the Monitor Stations (MS) and the Ground Antennas (GA). The Master Control Station is located at Falcon Air Force Base in Colorado Springs, Colorado, USA. Monitor Stations are located at Hawaii, Ascension, Diego Garcia and Kwajalein. Figure 2 on the next page is a diagram showing MCS, MS and GA sites.

The User Segment includes all of the military and civil equipment intended to provide and process position, velocity and time (PVT) information.

The Space Segment

The GPS Space Segment consists of the 24 satellites in semi-synchronous orbits around the earth. This is commonly referred to as the GPS satellite constellation. The constellation has four operational satellites in each of six orbital planes.

The orbital planes of the satellites are inclined 55 degrees (relative to the equator). The orbital planes are spaced at 60-degree increments around the equator as viewed from the poles. The satellites are at an altitude of 20,200 km (12,550 miles) and each completes an orbit in 12 sidereal hours, which is about 2 minutes less than 12 normal hours. There are 24 sidereal hours in the time it takes the earth to rotate once with respect to the fixed stars (not the sun). This positioning of the GPS satellites ensures that a minimum of four are in view (observable) by a user anywhere worldwide at all times. Usually, more than four are observable, and often as many as eight are observable from most sites. See cover illustration.

The GPS satellites transmit radio frequency signals toward the earth. These transmissions convey the required information for the user equipment to make use of the GPS.

The provision of precise time and frequency signals from the spacecraft is aided by the presence of two cesium and two rubidium atomic clocks on each satellite. Only a single standard is used at any given time, so each satellite has good redundancy.

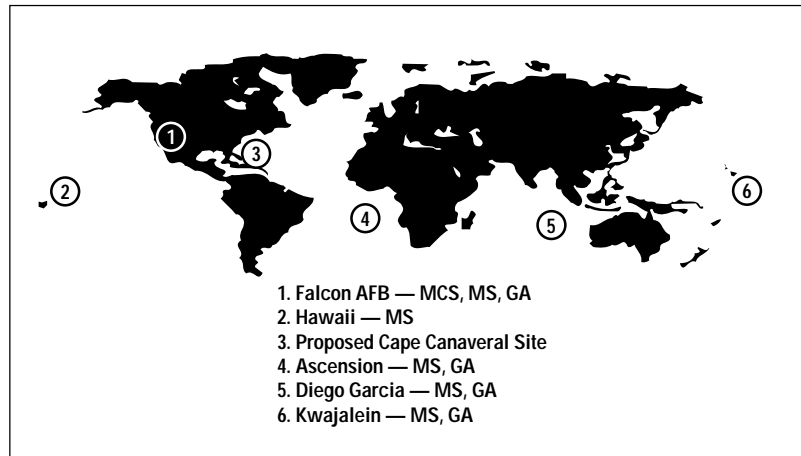

Figure 2. Locations of GPS Control Segment Stations

The Control Segment

The GPS Control Segment consists of a Master Control Station (MCS) at Falcon AFB (12 miles east of Colorado Springs, Colorado in the U.S.), and five Monitor Stations (MS) around the world. See Figure 2 above.

The Master Control Station (MCS) is the central processing facility for GPS. It is manned 24 hours a day, 7 days per week — no holidays allowed. The primary task of the MCS is to track, monitor, and manage the GPS Satellite Constellation. The MCS collects data from the Monitor Stations. It continuously estimates each satellite's position (ephemeris) and clock parameters. These estimates are uploaded through one of the Ground Antennas (GAs) providing the ephemeris and clock data to each satellite for retransmission in the navigation data message.

The Monitor Stations (MS) have highly accurate radio receivers located at precisely-surveyed locations. They passively track all GPS satellites in view, up to eleven at any one time, and collect

ranging data and timing from each. Little data processing actually occurs at an MS. The raw measurements and navigation data message observations are transmitted to the Master Control Station for processing.

Uploads to the satellites are sent by radio transmission through the Ground Antennas (GAs). GAs are also used for transmitting and receiving satellite-control information. Each Monitoring Station is equipped with a Ground Antenna to communicate with the satellites.

The User Segment

The User Segment is comprised of a variety of user equipment with receiver/processors specifically designed to receive, decode, and process the GPS satellite ranging codes and navigation data messages.

GPS provides services for two levels of users. These are referred to as the Standard Positioning Service (SPS) and the Precise Positioning Service (PPS). The latter is reserved, almost entirely, for the exclusive use of the DoD.

The Theory of GPS Operation

The U.S. DoD states very clearly in the Federal Radionavigation Plan (FRP) what SPS and PPS provide:

“SPS is a positioning and timing service which will be available to all GPS users on a continuous, worldwide basis with no direct charge. SPS will be provided on the GPS L1 frequency which contains a coarse acquisition (C/A) code and a navigation data message. SPS is planned to provide, on a daily basis, the capability to obtain horizontal positioning accuracy within 100 meters (2 drms, 95 percent probability) and 300 meters (99.99 percent probability), vertical positioning accuracy within 140 meters (95 percent probability), and timing accuracy within 340 ns (95 percent probability). The GPS L1 frequency also contains a precision (P) code that is reserved for military use and is not a part of the SPS. Although available during GPS constellation build-up, the P code will be altered without notice and will not be available to users that do not have valid cryptographic keys.

“PPS is a highly accurate military positioning, velocity, and timing service which will be available on a continuous, worldwide basis to users authorized by the DoD. PPS will be the data transmitted on GPS L1 and L2 frequencies. PPS was designed primarily for U.S.

military use and will be denied to unauthorized users by use of cryptography. PPS will be made available to U.S. Federal and Allied Government (civilian and military) users through special agreements with the DoD. Limited, non-Federal Government, civilian use of PPS, both domestic and foreign, will be considered upon request and authorized on a case-by-case basis.”

User Equipment

NAVSTAR GPS provides users with three dimensional position, velocity determination, and precision time. The term receiver/processor indicates a GPS receiver and/or other user equipment designed to track the GPS satellite radio signals and provide position and time information. Astonishing accuracy is provided to the user.

Generalized GPS applications include positioning service, providing users with highly accurate navigation and geodesy capabilities, and extremely accurate time reporting for device and event control.

GPS user equipment varies significantly in design and function. There is wide potential for specialized and varied applications and receiver designs are available for most user markets, such as aviation navigation, marine navigation, geodesy and timing. Many of these use databases and electronic charts to enhance the usefulness of raw latitude, longitude and time.

Hewlett-Packard has developed a unique set of timing equipment utilizing GPS as an SPS user. Using HP SmartClock Technology and special algorithmic filtering, PPS-like performance can be achieved for timing. These techniques do not help positioning accuracy.

GPS provides position and velocity information with respect to the World Geodetic System 1984 (WGS-84) map datum or coordinate system. Any other coordinate system or user-generated datum will require a translation. This is often done. GPS is not based on the location of ground-based transmitters. Therefore, the typical GPS receiver's location outputs cannot be directly used for navigation in relation to a fixed point, as with a Very High Frequency Omnidirectional Range or nondirectional beacon or LORAN. Instead, an area navigation scheme with waypoint information is used. The matter is easily handled by data processing and outputs can be customized for any specific need.

Technically there is a distinction between the terms positioning and navigation. However, for the purposes of the GPS user, the two terms are employed interchangeably. Remember, the Global Positioning System provides position, velocity, and time (PVT) information which can be used for navigation purposes.

Ranging Theory

GPS position determination is based on a concept called time of arrival (TOA) ranging. TOA is a complex way of saying signal travel time from one point to another.

Simply explained, TOA ranging involves transmitting a signal at a known time and measuring the arrival (reception) of that signal at a later known time. The interval between the known time of transmission and the known time of reception is the TOA value.

TOA Ranging Examples

As a simple example, the TOA ranging concept (based on the velocity of sound) is frequently used by adults and children worldwide. It is generally understood that in a thunderstorm, the distance from a lightning flash to your location can be simply figured by counting the seconds from when the visual flash is seen (transmission) until the audio thunder report is heard (reception). In this example, we can assume the perception of the lightning flash is instantaneous because the velocity of light is nearly a million times faster than sound traveling in air. The TOA is the time between the flash and the thunder.

Sound travels at about 330 meters (1,100 feet) per second. Hence, the thunder takes about three seconds per kilometer (five seconds per mile) to travel. Simply divide the TOA value (time between flash and thunder clap) by 3 to determine the range in kilometers between you (the receiver) and the lightning flash (the transmitter), or multiply by 0.2 to get the distance in miles. See Figure 3.

As a further example of the TOA ranging concept using sound waves, assume the transmitter is a foghorn that sounds precisely on the minute mark (precise and known time of transmission) and the receiver is a mariner listening for the foghorn. The mariner is equipped with a chronometer (accurate timepiece) to be used for timing purposes and a chart which shows the location of the foghorn.

For this example, the foghorn's sound arrives at the mariner's position exactly 10 seconds after the minute mark (precise and known time of reception) as indicated by the chronograph. The mariner's position relative to the foghorn (range) is then calculated by multiplying the TOA value of 10 seconds by the speed

of sound (1,087.1 feet per second at sea level at 32°F). The range (distance from the foghorn) is 10,871 feet. The mariner sets a compass to draw an arc corresponding to 10,871 feet at the scale of his chart. This is TOA-Based Range No.1, as shown in example A of Figure 4 on next page.

The mariner then locates a second foghorn on the chart and repeats the procedure. The mariner is located at one of the two positions where the range circles intersect. See example A in Figure 4.

This simple example of the TOA ranging concept is not without its difficulties. The range circles give two intersections (possible positions) so the mariner must know his position to eliminate ambiguity.

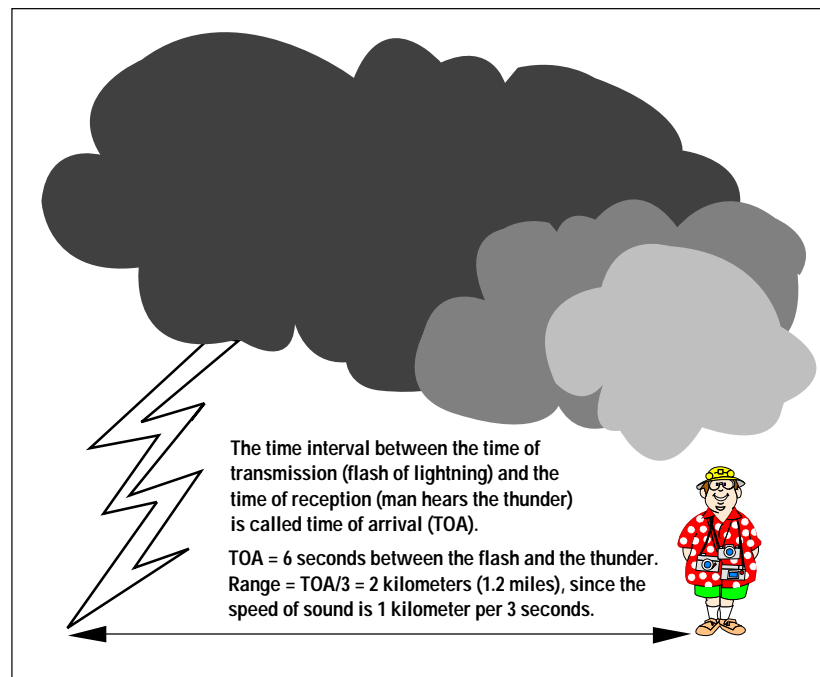

Figure 3. A basic lesson in TOA ranging

Intersection ambiguity can be eliminated by making range measurements to three foghorns. This will increase the number of intersection points, but only one intersection point will be common to all three TOA-based range circles. All other intersections are false positions. See example B in Figure 4.

The Need for Accurate Timing

The chronometer used for time measurement must be very accurate, or precision positioning will not be possible. Clock bias error, as an error in clock accuracy is called, delivers incorrect position.

If the mariner's chronometer in the first example was running one second fast, then the sound of the foghorn that arrived 10 seconds past the minute mark would have the appearance of arriving at 11 seconds past the minute mark on the mariner's chronometer. The additional one second would cause the mariner to compute an erroneous range of 11,958 feet from that foghorn (1,087-foot error). When ranging to a second foghorn, both of the TOA-based range observations would have range errors of 1,087 feet. Although the mariner would now have an erroneous position fix, the problem of clock bias errors and ambiguous intersections can be solved. See example C in Figure 4.

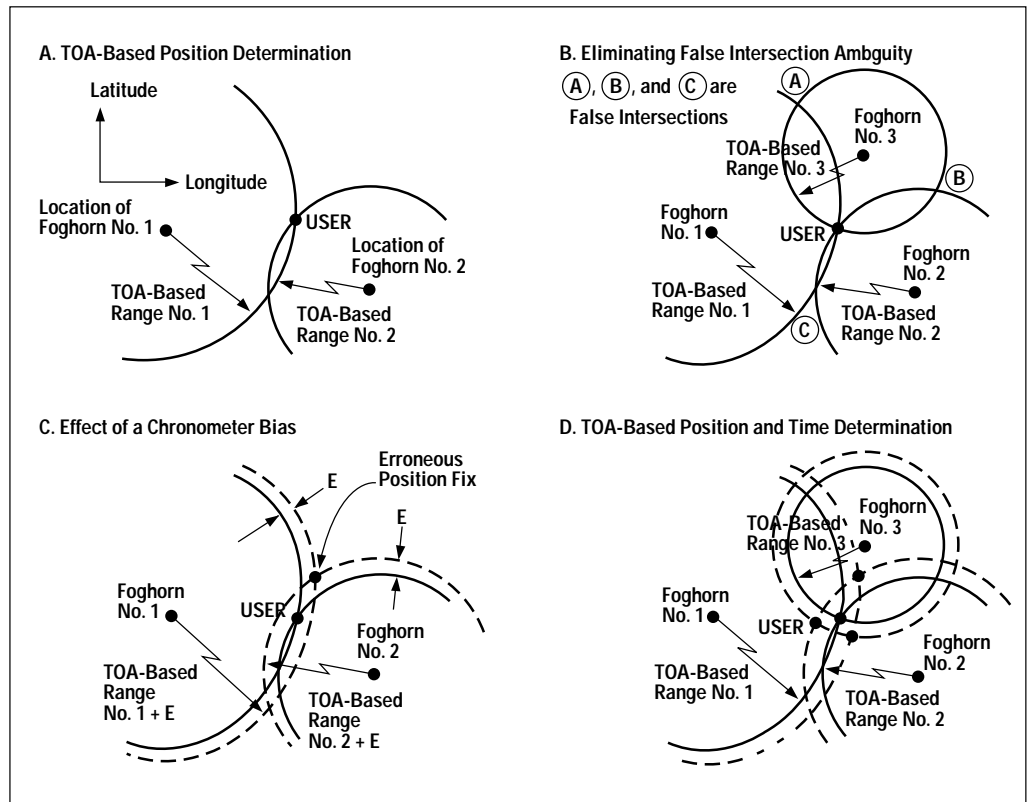

Figure 4. Examples of the Mariner's TOA ranging (U.S. Govt. Pub.)

Using three foghorns, note that three dual-foghorn intersections are near the mariner's true position. Distance E between the intersections of range circles from foghorns 1 and 2, foghorns 1 and 3, and foghorns 2 and 3 is a function of the chronometer's clock bias error. By moving the clock forward or backward until the three dual-foghorn intersections converge at the true position, the chronometer's clock bias has been determined. See example D in Figure 4.

As a result of using three foghorns (transmitters) with certain known facts about each (exact position and time of sounding), the ranging information can be applied to a map to determine latitude and longitude coordinates. Further, the chronometer's clock bias error becomes a known and correctable quantity.

In simple terms, the same line of thinking follows for GPS. The signal velocity becomes the velocity of light instead of sound. Three position coordinates (latitude, longitude and altitude) are needed instead of two. Hence, four satellites are needed instead of the three foghorns.

Time and Position Theory

At the heart of GPS is the timing accuracy available from atomic clocks. Albert Einstein gave us the relationship between space and time — the four dimensions of relativity. These four dimensions may be thought of as latitude, longitude, altitude and time, or in shorthand x , y , z and t . GPS is the first engineering implementation of relativity and would not work without it. Fortunately, an understanding of relativity is not necessary to gain an understanding of how GPS works. The relativistic terms are accounted for in the design of the satellite clocks and in the receivers that properly process the data.

The orbit period for GPS places them at a distance of about 4.2 earth radii from the center of the earth as illustrated by the feet of the tripod in Figure 5. The relativistic velocities of the space vehicle (SV) clocks cause them to lose about 7.2 millionths of a second (7.2 microseconds) per day with respect to the earth. On the other hand, their altitude (often called the gravitational redshift) causes them to gain 45.6 microseconds per day. The net is a gain of 38.4 microseconds per day. This accumulation is enormous compared to the few nanoseconds synchronization accuracy desired for the system, since a microsecond is 1,000 times a nanosecond. The SV clocks are constructed on earth to lose 38.4 microseconds per day, so that when they are in space they appear to be running at the right rate.

Because the earth is rotating and generally all receivers are moving, the relative velocities and positions between SV clock and receiver clock have to be accommodated in the receiver software. It is not known that all receivers are performing this calculation correctly. This is a receiver manufacturer's responsibility. Just due to the rotating earth alone, hundreds of nanoseconds of error can occur in synchronizing clocks around the globe unless the calculations are done correctly.

The U.S. Air Force has created an interface control document (ICD 200-B) which describes how to perform these calculations.

Once the relativity is properly included, GPS can be thought of in a traditional time-of-flight way. By measuring the time of arrival (TOA) of a signal — knowing the time it began and its velocity — the range or distance between the sender and the receiver can be easily calculated.

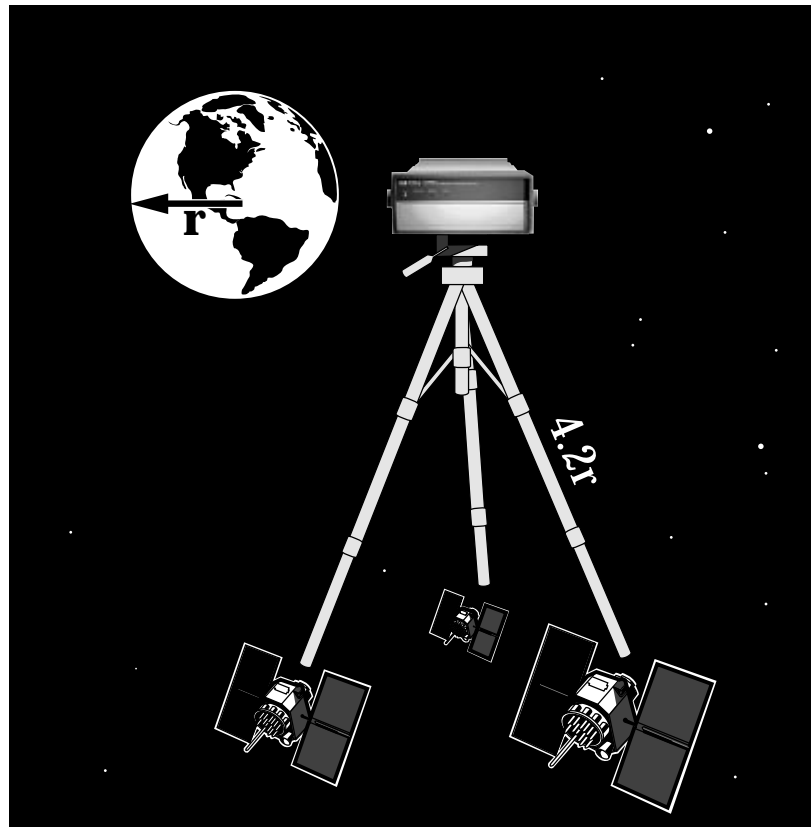

Figure 5. Three fixed points in space given by three satellites and the lengths (given by time of flight of the signals from the satellites) determine the position of the GPS receiver's antenna like the tripod fixes the position of the telescope.

For GPS, the velocity of light is used instead of the velocity of sound for determining range. As Einstein taught us, time and space are interlinked (see Figure 5). Consider the tripod shown in the illustration with the GPS receiver on top. The position of the receiver antenna on earth is determined by the positions of the three satellites at the bases of the tripod legs. The positions of the GPS satellites are determined by the GPS control segment and each satellite broadcasts, as part of its message, its own position.

The relativistic times broadcast by the satellites are kept synchronous by the control segment as well. Suppose there is also a synchronous atomic clock in the GPS receiver. Since all four clocks are ticking together and the ticks from the satellites are broadcast toward the earth at the velocity of light (30 cm — about 1 foot — per ns), the earth GPS receiver clock can measure how long it takes each signal to arrive (like the propagation of the sound signal from the lightning strike). Knowing the propagation time of each of the three legs allows the receiver to calculate the length of each leg (the TOA times the velocity of light). If the positions of the satellites are known to one meter and all four clocks are synchronous to better than three nanoseconds, the position of the GPS receiver could be calculated to an accuracy of about one meter.

Though the above example outlines the essential principles, the actual operation of GPS is somewhat different. In the above example, the receiver already knew the time, and from the measurements could calculate the latitude, longitude, and altitude of the GPS receiver's antenna, which is the receiving point of the signals. Since having an atomic clock at the receiver would be both expensive and bulky, adding a fourth satellite makes it possible to calculate the time as well as the latitude, longitude, altitude of the receiver clock. In other words, the four legs from the four satellites to the receiver antenna yield four equations, and there are four unknowns: x , y , z and t . Having four satellites provides a significant cost savings in the user equipment.

The receiver only needs to have a short-term stable quartz clock, which can easily be used to measure the time differences of the TOA of each of the received signals to a precision of a nanosecond. The clock bias for this inexpensive receiver-clock can be calculated using the data from all four satellites (as in the foghorn example earlier). In other words, there will be a conceptual sphere around each of the four SVs. The radius of each sphere will be the calculated range. The only way the four spheres will intersect at a point is if the time used in the receiver's calculation is synchronous with

GPS time. Hence the receiver's computer can calculate clock bias for inexpensive clock at the time of the measurement — effectively giving it the accuracy of the atomic clocks in the GPS.

Potential error sources in GPS arise from sundry sources. The broadcast positions (ephemerides) of the satellites are not known precisely. The velocity of the signal from the satellite is perturbed by the ionosphere and the troposphere. The broadcast times from the four or more satellites are not synchronized perfectly. Multipath distortion affects the received signal at the antenna causing errors in the calculated TOA value. Antenna and receiver electronic noise and cable delay variations with temperature, for example, add to the uncertainties in the accurate determination of x , y , z and t .

The accuracies and precisions available from GPS vary dramatically, depending on the methods of utilizing the GPS signal information. Positioning accuracies vary from sub-centimeter for differential measurements to over 100 meters for a simple SPS user. Timing precisions vary from sub-nanosecond to hundreds of nanoseconds, and accuracies often depend on user and/or manufacturer's care in setting up and calibrating the equipment.

Accurate Time

The accuracy of a clock can be thought of as the degree of agreement with some accepted reference clock. GPS time can be thought of as a software clock. GPS time (often called the composite clock) is computed as a weighted set of all the readings of the current GPS clocks. The Master Control Station (MCS) continually estimates the clock bias for each of the SV hardware clocks so that the satellites can broadcast its estimate of GPS software time. The errors in the computed GPS time will be affected by the above sources and will consist of both systematic and environmental perturbing sources as well as random variations.

The official reference clocks for the world are International Atomic Time (TAI) and Coordinated Universal Time (UTC). These time scales are generated by the Bureau International des Poids et Mesures (BIPM). Both scales use exactly the same value for the System Internationale (SI) second based on the cesium atom and differ in their readings by an integer number of seconds (called leap seconds). Under international agreement as announced by the International Earth Rotation Service (IERS), leap seconds are added to UTC to keep it within 0.9 seconds of earth time (UT1).

GPS time has no leap seconds and its time is given by TAI minus 19 seconds. The GPS composite clock is steered to be synchronous to a very high accuracy with the international UTC scale's modulo one second. This will be discussed in more detail later in this application note. All that is required for accurate positioning with GPS is that its time be consistently available from all the satellites. This is currently being done at the level of about 10 ns. By steering procedures, GPS time is now kept accurate within about 20 ns with respect to TAI-19s.

GPS also provides as part of its data message the corrections to apply to GPS time to obtain UTC. The reference in this case is the master clock at the US Naval Observatory (USNO MC). When these corrections are applied, the time accuracy achievable is typically less than 10 ns.

The above levels of accuracy are not available to the SPS user without special processing because of the degradation purposely imposed by the DoD for security reasons. This degradation is called Selective Availability (SA). Hewlett-Packard implements a unique SA filtering algorithm which removes most of the effects of SA for timing purposes. Hence, the above accuracies are potentially available with the proper choice of Hewlett-Packard equipment and with proper set up procedures.

GPS Transmitted Message

The orbiting GPS satellites are the broadcast beacons (transmitters). The satellite's radio signals travel at the speed of light (299,792,458 meters per second, about 30 cm/ns or 186,282 miles per second) and consist of pseudorandom noise (PRN) modulated L-band radio waves. The PRN sequences, coarse/acquisition codes (C/A-codes), and precision codes (P-codes) are predetermined strings of one and zero data bits generated by an onboard clock. This clock provides the exact transmit time of the broadcast signals (precise and known time of transmission).

For determining x, y, z and t, the GPS satellites transmit (using spread spectrum techniques) on two frequencies referred to as L1 and L2:

L1 = 1575.42 MHz
L2 = 1227.60 MHz

The GPS satellites transmit the 1 and 0 data bits by the L1 and L2

carrier signals, digitally modulating, using binary phase shift keying (BPSK). BPSK moves the carrier phase in one direction for a digital PRN code change from 1 to 0 and in the other direction for a change from 0 to 1. GPS differs from AM/FM radio, and most other radio systems, in that all satellites transmit on exactly the same L1 and L2 frequencies. Each satellite has a different PRN code sequence. Hence, by locking onto a particular code sequence, a receiver can select a unique satellite. The rest of the satellite signals look like white noise because the codes are randomly (in a known way) distributed.

The P- and C/A-codes are also known and predictable relative to the start time of the code sequence. Therefore, by use of a properly designed receiver/processor, the user can precisely replicate the same code the satellite will send at any given time. When the replicated P- or C/A-code sequences are mixed with the L-band radio signals transmitted from the satellites

(offsetting the replica sequence forward or backward in relation to time), a match of the incoming signal with the replica will be made. This match is called a correlation, and the amount of time offset computed by the receiver to achieve correlation is directly proportional to the range between the receiver and the satellite. The result is called the observed TOA value. See Figure 6.

GPS Clock Bias

If the GPS receiver clock was synchronized to the onboard GPS satellite clocks (GPS system time), the TOA values observed by the receiver would be equal to the geometric ranges between the satellites and the user, divided by the speed of light.

In practice there are clock biases in the receiver's clock as well as in the SV clock. Radio signals (traveling at the speed of light) require clock accuracy to within a few nanoseconds. Part of the information in the message being transmitted is the precise time difference between the

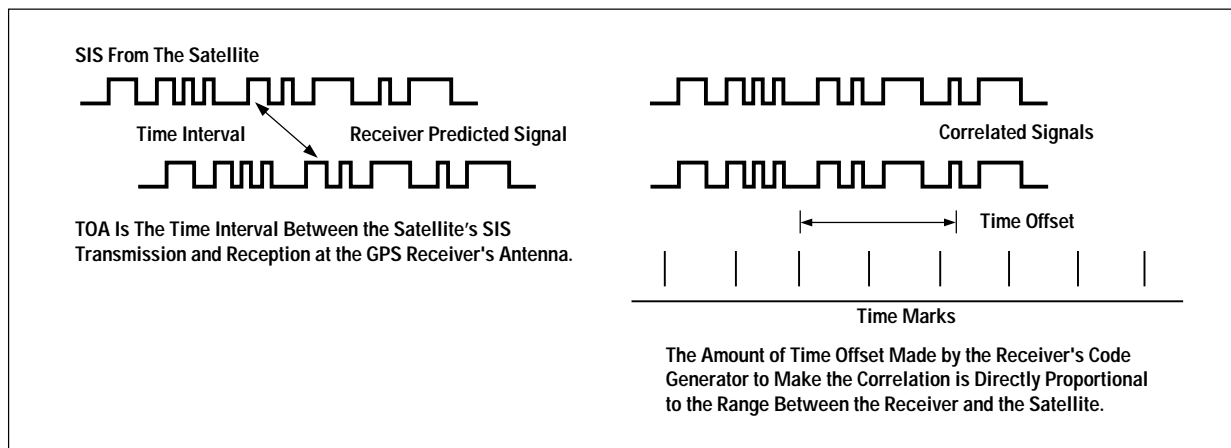

Figure 6.
Offsetting by Time

satellite's free running clock and GPS system time. The computer in the receiver uses the four satellites to calculate its internal clock bias. These two pieces of information are used by the receiver in order to estimate the true range to the satellite.

When the clock biases are cancelled, the receiver's calculated TOA value times the velocity of light becomes the range from each satellite. The raw measurements before correcting for clock bias are called pseudorange (PR) measurements.

Note how the user's receiver performs all the functions of the mariner's navigation system. The receiver's antenna (ear), accurate clock (chronometer), plotting table (charts), and calculator (data processor), are all replaced

by one device. This single piece of equipment, consisting of a radio receiver and a data processor, does all the positioning calculations and reports time with no operator intervention.

Position and Time Computations

As the GPS receiver begins tracking four satellites, receiving the PRN sequences for each, and generating TOA values, the receiver's data processor takes over. It samples the TOA values for each of the four satellites and multiplies them by the speed of light to produce four pseudorange measurements. The processor then compensates the PR measurements for deterministic errors including time differences between an individual satellite's clock and GPS time, atmospheric radio signal distortion, effects of relativity, and internally-generated receiver noise.

The receiver's data processor obtains the necessary information to make these compensations from the navigation data message (NAV-msg). The NAV-msg is superimposed on both the P-code and C/A-code satellite signals at a data rate of 50 bits/s and contains 25 data frames. Each data frame consists of 1,500 bits divided into subframes of 300 bits each. A GPS receiver requires thirty seconds to receive one data frame and 12.5 minutes to receive all the 25 data frames available. See Figure 7.

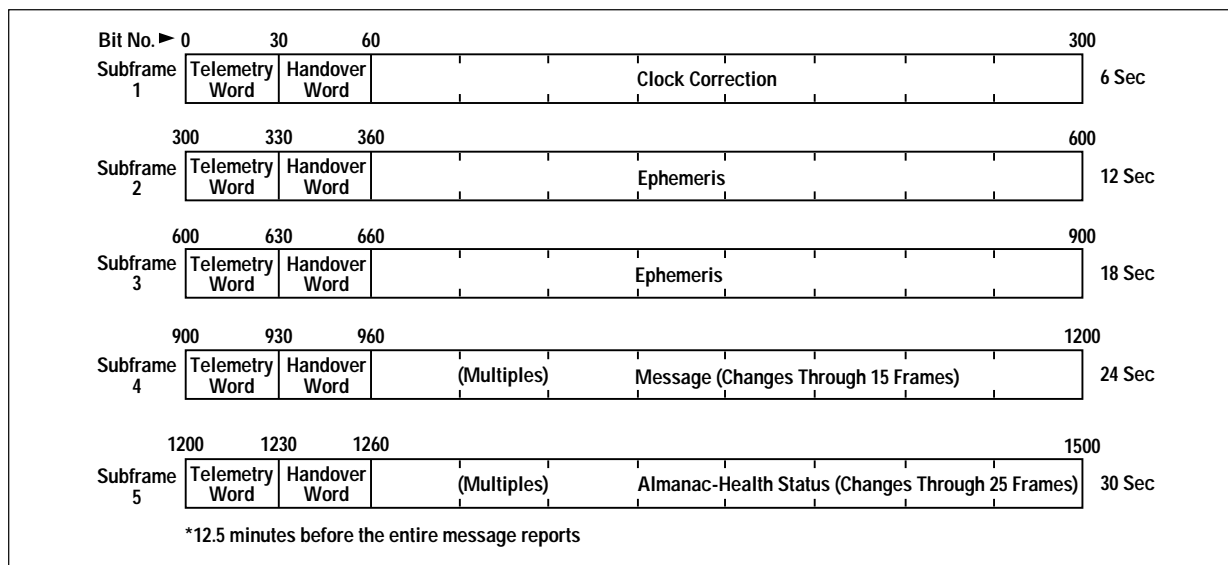

Figure 7. The NAV-msg (U.S. Govt. Pub.)

The navigation data message (NAV-msg) contains GPS time of transmission, ephemeris or orbital position data, clock data of the particular satellite being tracked, and almanac data for the remaining satellites in the constellation. Coefficients for calculating Universal Time Coordinated (UTC) and the ionospheric delay model (propagation delays and atmospheric radio signal distortion) for C/A-code users are also part of the NAV-msg. The NAV-msg is normally valid for a four-hour period.

The broadcast ionospheric delay model is about 50 percent accurate. This can give rise to errors of several nanoseconds. PPS receivers have the potential through the use of the L1 and L2 frequencies to measure the ionospheric delay, reducing this

inaccuracy to the order of a nanosecond.

Adjustments to the pseudorange measurements are made by the data processor portion of the GPS receiver, then the position/time solution calculations are made. The position/time solution process consists of a mathematical solution of four ranging equations, using the four adjusted pseudorange measurements to determine the four unknown quantities of the x, y, z position coordinates and the receiver clock bias. See Figure 8.

The NAV-msg contains the information required by the receiver's data processor to compute the satellite's position at any point in time. The results of the receiver's processor, sometimes called a fix,

are in coordinate terms, latitude, longitude, and altitude.

Special timing receivers, depending upon their style and parameter settings, will either produce an estimate of GPS system time or UTC, or they will measure a local reference clock against either or both GPS time and UTC.

Position and Time Reporting

The adjustments and mathematical solution are, in reality, a very high-speed version of the mariner plotting out a two-dimensional position fix and zeroing the chronometer clock bias error using the intersection of three TOA-based range circles. GPS is a four-dimensional system (latitude, longitude, altitude and time), so four TOA-based range spheres are needed for a complete solution.

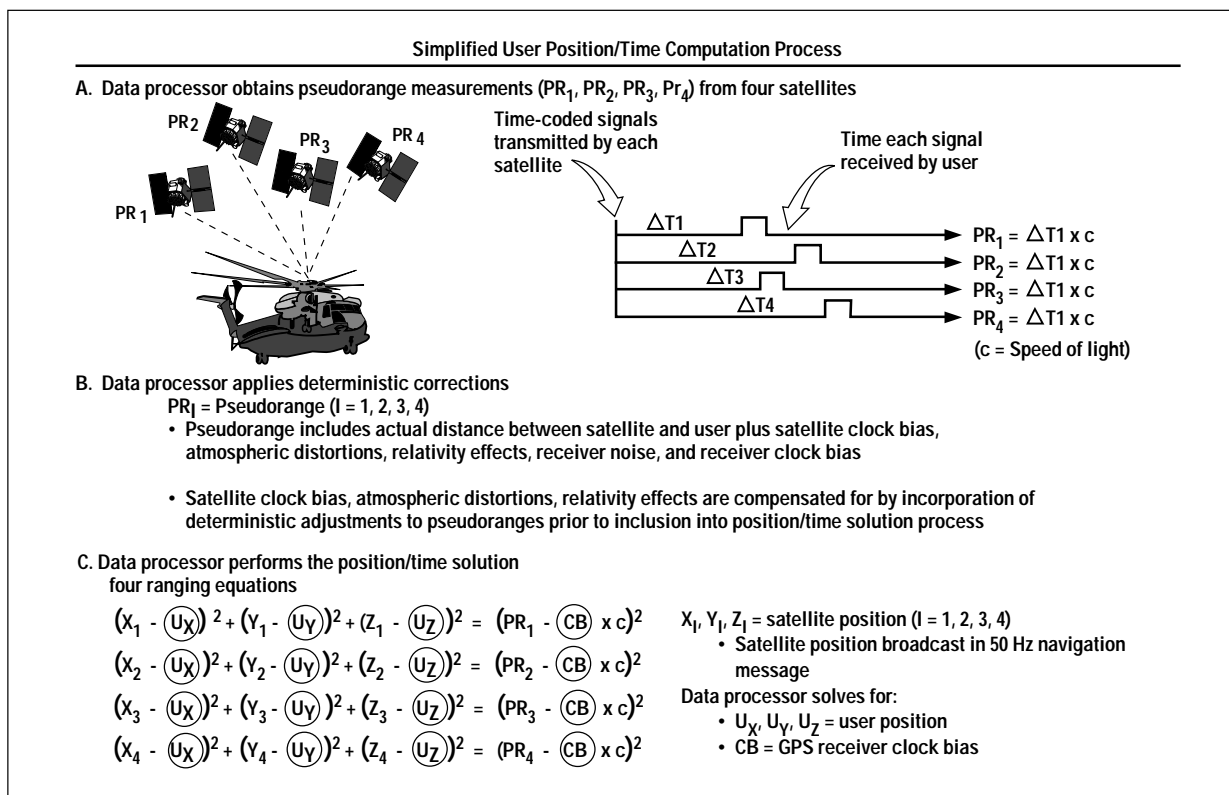

Figure 8. Simplified Computations
(U.S. Govt. Pub.)

A positioning receiver does not need accurate time, since it only needs to remove time or receiver clock bias in solving for x, y and z. In fact, time delay variations in the antenna and receiver that are common to all four satellites used in the solution will cancel in common-mode fashion.

A receiver/processor can determine its position using pseudorange measurements from fewer than four satellites if external aiding information (exact altitude measurements from a barometric altimeter or the exact GPS time) is available. An aiding source can replace one satellite-based PR measurement in the solution process. If both exact altitude and exact GPS system time aiding were available, position, velocity, and time (PVT) could be solved with measurements from only two satellites.

GPS positions are referenced to the electrical phase center of the receiver's antenna, not the receiver's location. The antenna is the actual point of signal reception. Therefore it is the antenna's position that is determined.

Some receivers don't produce timing information and are only used for position or navigation purposes. Accurate timing receivers require some special care in their design.

Time and Time Transfer and Frequency

GPS provides time traceable to UTC as produced by the U.S. Naval Observatory Master Clock (USNO MC). With its rate synchronized with the international definition of the second, and with UTC (USNO MC) time synchronized well within 20 ns of UTC, the GPS system is a worldwide resource for precision time.

Note, these accuracy values only apply to time results based upon a receiver's solution for the four ranging equations and do not apply when using specialized time-transfer receivers designed to exploit GPS as a precise time and frequency transfer total. There are at least six different methods of using GPS for timing. The three most popular ones will be touched on in this application note.

The GPS common-view method is used to transfer the time of about 300 clocks to the BIPM for the generation of UTC. It is the most accurate operational method to date. Two locations in common view of a GPS satellite measure the TOA over the same interval. Subtracting these two measurements cancels the GPS clock bias and much of the ephemeris error. This leaves the time difference between the clocks at the two locations. Precision and accuracies of a few nanoseconds are commonly achieved.

This basic concept requires the receiver to be fixed at a known location, thus allowing the receiver to use all pseudorange measurements solely for timing.

In addition, this common-view method is used for comparing the time and frequency of clocks at international timing centers for

millisecond pulsar timing, synchronizing and syntonizing NASA JPL's Deep Space Network, and for several other time and frequency calibration facilities.

Other applications using precise timing include radio paging systems designed to share channels (as required by a recent FCC ruling regarding Private Carrier Paging), time division of frequencies (channels) in the cellular and other communication industries, and other radio spectrum efficient operations. Many of these communication applications base their entire operation on one pulse-per-second (pps) timing rather than on GPS or UTC.

GPS is an excellent resource for pps timing over wide geographical areas. For example, the specific in-view satellites used for PVT information will normally be very similar, at any given time, over the entire continental U.S. This makes precise time synchronization over an area this size relatively easy.

Signal Acquisition

The GPS receiver detects the satellite constellation's spread spectrum broadcasts (SS), which are actually below the earth's natural radio noise level. After initial detection, the signal is effectively amplified by use of the processor-predicted P- and C/A-codes and collapsed into the original carrier frequency band, where it is concentrated and amplified above the natural noise level.

At this point the signal can be referred to as locked and it becomes useful.

The minimum required signal strengths at a GPS receiver antenna are:

- frequency L1 C/A-code: -160 dBW
- frequency L1 P-code: -163 dBW
- frequency L2 P-code: -166 dBW

Satellite tracking sequences begin with a determination by the receiver of which satellites are visible (useful) for tracking. A search of the sky is made by sequencing through the possible or probable PRN codes being transmitted by the satellites to locate and lock onto any single satellite in view. Once a satellite is located and locked, the receiver reads the navigation data message (NAV-msg) to obtain current almanac information about the other GPS constellation satellites.

Accuracy Limiting Factors

The potential accuracy of a GPS receiver's position solutions is determined by two very important factors:

1. Measurement errors in the pseudoranges.
2. Satellite-to-user geometry.

Knowing both these factors for a specific GPS receiver at a particular point in time and space allows an understanding of the limitations of GPS and enables forecasting of the receiver's position and time accuracy.

The error in the receiver's measurement of the pseudoranges from each satellite is called the user equivalent range error (UERE) and is the product of:

1. Uncertainty in the GPS satellite's clock bias.
2. Uncertainty in the satellite's ephemeris.
3. Errors in the satellite-broadcast NAV-msgs.
4. Imprecision of receiver PRN sequence tracking design.
5. Errors in calculation of the ionospheric model.
6. Errors in location, antenna delay, antenna cable delay, tropospheric effects, solar flares and others.

The UERE is further affected by the quality of the received satellite signals and will vary between satellites and times. Due to differences in receiver designs, the UERE will also vary between different user equipment. See Figure 9.

Dilution of Precision (DOP) is the second accuracy-limiting factor. It is a geometric quantity depending upon the relative positions of the user and the selected satellites. High values of DOP cause small errors in range measurements to become large position errors. For this reason, the four satellites selected by the receiver to determine PVT must represent low DOP values. The DOP limiting factor is independent of the quality of the signals or the type of GPS receiver (providing the same four satellites are selected). Basically, DOP is an amplification factor that multiplies the UEREs and increases the receiver's PVT solution errors.

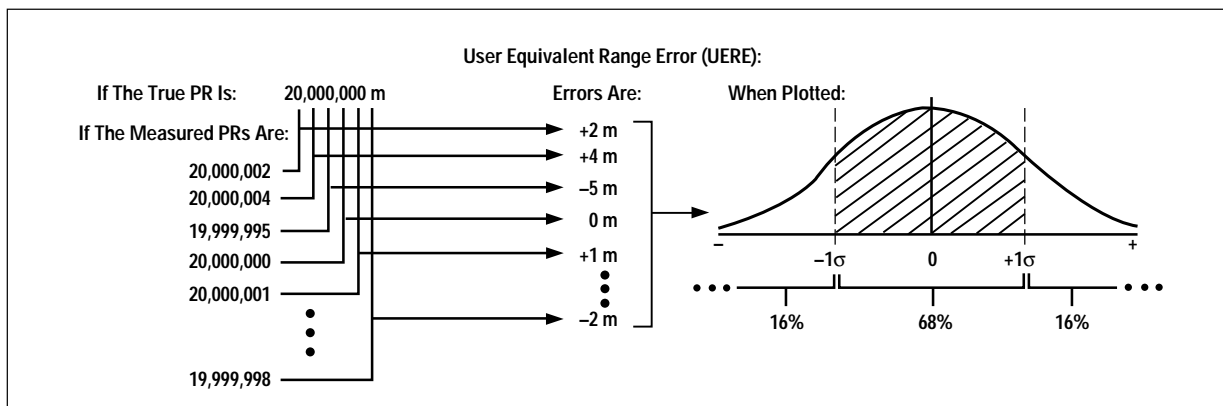

Figure 9. UERE
(U.S. Govt. Pub.)

Good DOP indicates that the satellites exhibit good geometry relative to the user. Good DOPs are indicated by low numbers and poor DOPs by high numbers. The lowest numbers occur when the selected satellites are widely spaced in the sky above the GPS receiver. See Figure 10.

Poor DOP occurs when the satellites are close together or when they form a row or circle. It is possible for poor DOP numbers to be so high that the receiver is unable to process a solution. See Figure 11.

Note: The best possible satellite geometry for PVT solution requires one satellite to be directly overhead and three other satellites equally spaced around the horizon.

Each of the position and time solution dimensions has a specific type of DOP involved with satellite geometry:

Vertical or spherical dimension (VDOP) — altitude errors.

Horizontal or circular dimension (HDOP) — latitude/longitude errors.

Position (PDOP) — combination of HDOP and VDOP.

Time (TDOP) — relates to VDOP, HDOP, and PDOP.

Time transfer (TTDOP) — relative to single unknown solution.

Position and Time Errors

Accuracy of the position and time solutions obtainable from a GPS receiver are the product of the two factors UERE and DOP.

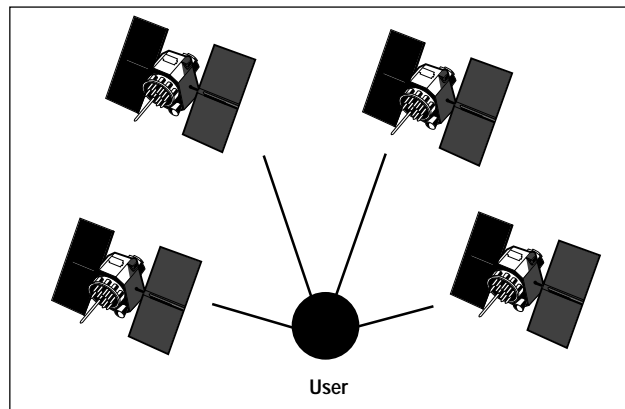

Figure 10.
Good Dilution of Precision (DOP)

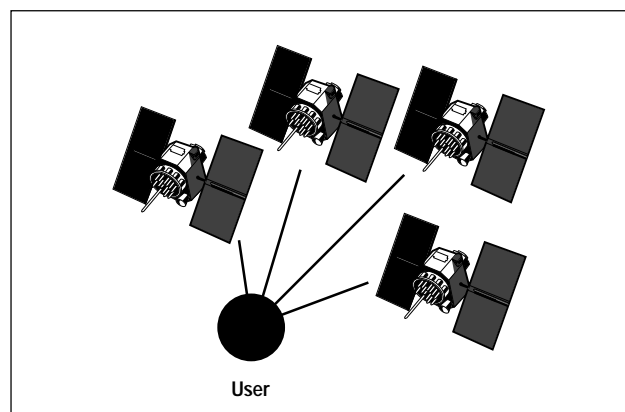

Figure 11.
Poor Dilution of Precision (DOP)

Knowing the UERE and DOP factors for a particular receiver at a specific time and place allows the forecast of that unit's position time errors. Forecasting is essential to provide:

1. Real-time performance estimation within the GPS receiver.
2. Planning and analyzing the use of GPS.

It is easy to forecast position and time errors when all the satellite signals give the same UERE. In such a case, the forecast navigation and time errors are computed

by simply multiplying the appropriate DOP value by the common satellite UERE value.

DOPs are forecast as a function of the user's position/time, the number of satellites visible, and the satellite locations. The GPS receiver's portion of the UERE is usually compensated for by the manufacturer. The satellite portion of the UERE is forecast by the GPS Control Segment and is provided to the user's receiver as a part of the NAV-msg.

The average UERE and DOP values for the composite global sample space (upon which the four GPS accuracy specifications are based) are:

UERE value for PPS receivers is 7.0 meters (22.96 feet) one sigma.

UERE value for SPS receivers is approximately 32 meters (104.99 feet) one sigma.

DOP numbers for PPS receivers: HDOP 1.5, VDOP 2.0, PDOP 2.5, and TDOP 1.1.

DOP numbers for SPS receivers: HDOP 1.6, VDOP 2.2, PDOP 2.7, and TDOP 1.3.

Methods of Increasing GPS Accuracy

GPS can exhibit variations of accuracy; among the causes are propagation anomalies, errors in geodesy, accidental disturbances of signal timing, or Selective Availability (SA — official degradation by the DoD for national security reasons). The SA can occur in the form of dither on the satellite clock signal, which is not reported in the NAV-msg, and/or in an erroneous broadcast ephemeris. The adverse effects of these variations may be reduced or eliminated by using the common-view method, by Differential GPS (DGPS) and Enhanced GPS (EGPS) techniques.

DGPS Operation

Differential GPS operation uses a precisely located reference station equipped with an all-in-view GPS receiver to measure pseudoranges to each satellite. By comparing a calculated range and the measured pseudorange, correction information is computed for each pseudorange measurement. This correction information is then broadcast to nearby GPS users (equipped with Differential GPS receivers).

Differential corrections to SPS improve positioning accuracy from 100 meters (328.1 feet) (2 drms) to better than 10 meters (32.8 feet) (2 drms). Time determination is likewise improved. The geographical area over which DGPS corrections can be made from a single differential reference facility can vary from a small and specific target such as an airport, to an area covering thousands of square miles.

DGPS stations are currently being deployed rapidly by the U.S. Coast Guard and many others. Also, private DGPS providers exist in most areas of the U.S. Many transmit in the FM radio band, charge for their services, and provide DGPS coverage in areas well-removed from the coastline and river systems that the Coast Guard doesn't serve.

Enhanced GPS

Enhanced GPS (EGPS) is a means of algorithmic filtering the effects of SA on SPS accuracy. This new approach developed at Hewlett-Packard has been shown to provide real-time accuracy to 20 nanoseconds, or better depending on the quality of the reference

clock used in or with the GPS receiver. With a quartz crystal oscillator for the clock, the EGPS delivers about 20 ns (rms), with a rubidium clock about 10 ns, and with a cesium clock about 3 ns. Note that receivers operating in the EGPS mode must be stationary, as EGPS is not dynamic in nature and cannot operate on moving platforms.

GPS Operational Capability Attainment

Initial Operational Capability (IOC) was attained in December 1993, when the system configuration met the configuration defined in the 1992 FRP (24 GPS Block I/II/IIA type satellites operating in their assigned orbits, available for navigation use and providing positioning and time service). The satellite total of 24 includes three operational spares, in orbit, that can be relocated to replace a failed or missing satellite.

The IOC notification was made by the Secretary of Defense following an assessment by the system operator (USAF) that the satellite constellation could sustain the required levels of accuracy and availability.

Prior to the IOC notification, GPS was considered to be in the process of development, meaning that signal availability and accuracy were subject to change at any time.

Full operational capability (FOC) defines the condition when the GPS system is capable of providing full and supportable military services.

GPS Nonmilitary User Concerns

Although conceived and funded by the United States Department of Defense (DoD), GPS has grown into such a technological giant that changes and/or cancellations are now virtually impossible, except in the case of a national defense emergency. The DoD's system of Selective Availability (SA) was put in place to degrade the accuracy of civilian GPS signals in the event of such an emergency. This is a source of concern among commercial and international GPS users.

To understand the pervasiveness of GPS, consider a recent GPS World Receiver Survey which lists over 300 units available from 50 companies. The number and wide variety of uses of these receivers are impressive. If GPS were to be turned off permanently tomorrow, we would lose most of our precision surveying capabilities, most of our long-distance communication, a major portion of the small boat, plane and other navigational uses, and there would be significant interruption of commerce. The GPS-aided Intelligent Vehicle/Highway System (IVHS) currently being equipped in new automobiles by both Detroit, Michigan and Japan would be shut down. The FAA would be disrupted. That agency has adopted GPS as its Class 3 (all-weather) landing system, and it is also developing a wide area augmentation system (WAAS) based on GPS which will be designed to provide better than 1-meter accuracy.

In March of 1996, the White House, Office of Science & Technology Policy, and U.S. National Security Council released a statement addressing these very real concerns. The release outlines "a comprehensive national policy on the future management and use of the U.S. Global Positioning System (GPS) and related U.S. Government augmentations" approved by the President. The goal of this policy is to manage the use of GPS to "support and enhance our economic competitiveness and productivity while protecting U.S. national security and foreign policy interests."

The policy's guidelines declare that the U.S. will continue to provide GPS "for peaceful civil, commercial, and scientific use on a continuous, worldwide basis, free of direct user fees." In the year 2000, the President will begin making annual determinations on continued use of GPS Selective Availability (SA). The policy's guidelines state that SA is planned to be discontinued within a decade, allowing time for U.S. military forces to prepare for operations without it.

Hewlett-Packard GPS Synchronization Products and Applications

Hewlett-Packard provides a range of timing and synchronization products based on advanced GPS technology. These products include:

- Primary reference sources. A primary reference is often referred to as the master clock. Top level synchronization solutions demand the highest accuracy and best long-term stability since they are used to drive multiple lower level synchronization units.
- Synchronization units. These solutions deliver synchronization signals at specific points within a network or site, or distribute a reference source to multiple points. Since many organizations require large numbers of these units, they must be affordable while maintaining accuracy and stability throughout the synchronization infrastructure.
- Specialized products and custom solutions. HP offers customization services and specialized products, such as the HP 59551A, for synchronizing measurements for power transmission systems.

General-Purpose Metrology and Manufacturing

The HP 58503A GPS Time and Frequency Reference Receiver, a lightweight compact module, fits comfortably into not only controlled lab environments, but also a variety of general-purpose calibration and manufacturing applications that require precision time or synchronization.

**The HP 58503A
GPS Time and
Frequency Refer-
ence Receiver**

The HP 58503A source maintains frequency accuracy of better than 1×10^{-12} , even in the presence of Selective Availability. This performance, combined with the unit's low cost, makes it an attractive lab alternative compared with more expensive cesium and rubidium solutions. Manufacturing companies are taking advantage of the HP 58503A. Because of its low cost, the HP 58503A can be located anywhere precision time and frequency are needed. This can eliminate or simplify distribution systems and expensive cable runs.

In operation, the HP 58503A requires no periodic adjustments or calibration which, along with its greater than 100,000-hour MTBF, provides an extremely low cost of ownership. If the GPS signal is lost, the HP 58503A automatically goes into its intelligent holdover mode. An RS-232 port and a TTL alarm output (BNC) allow easy performance monitoring. Either of these outputs also provides automatic monitoring of the status of the HP 58503A.

Synchronizing Wireless Networks

Accurate timing is essential for the evolving digital cellular applications. Soft handoffs — passing a CDMA user from one base station to another — requires exact synchronization. The HP 58503A general purpose reference source can deliver an accurate and stable synchronization signal for digital base stations and other points throughout a service provider's network. Other features it brings to the wireless market include:

- Shortened time to market.
- Lowered costs.
- Improved system and service quality.
- Reduced project risk.

Today, many wireless networks also require customized designs for timing and frequency synchronization and distribution. For network equipment manufacturers building volume quantities of wireless communications base stations or other equipment, the



HP customization services can shorten implementation cycles and lower in-house development costs without sacrificing quality and affordability.

Custom designs use many of the same technologies incorporated in the HP 58503A and are tailored to client specifications. A custom design can accommodate the needs of any analog or digital cellular, special mobile radio, or personal communication system manufacturer. Clients specify the exact form, fit, and function of the equipment needed for synchronizing base station operation. Custom products are manufactured to HP's quality standards and are supported worldwide.

Synchronizing Telecommunications Networks

Telecom digital networks require highly-reliable, low-cost sources of precision frequencies in order to maintain data integrity and guarantee the delivery of high-quality services. The HP 55300A GPS Telecom Primary Reference Source gives service providers a lightweight, compact module that fits comfortably into controlled lab environments, base stations, and remote or unattended applications.

The HP 55300A source maintains frequency stability of greater than 1×10^{-12} , even in the presence of Selective Availability. The module "flattens" existing digital networks and delivers Level 1-type performance to Level 2 and 3 locations. The HP 55300A module provides a low-cost reference source that improves network services and provides scalability to synchronization solutions.



The HP 55300A GPS Telecom Primary Reference Source

For distributing synchronization reference sources, the HP 55400A Network Synchronization Unit can monitor up to five different in-house or GPS reference sources and deliver as many as 400 outputs to different points on the network. Configured as a master subrack and associated expansion sub-racks, the HP 55400A capacity allows the economical distribution of multiple output signals throughout a large facility.

The redundant architecture and "hot swapping" features of the HP 55400A minimize interruptions to the network being synchronized. The active input can be switched on-line without any phase hits for the output signals. Redundant pairs of input references and output cards offer one-to-one protection, and redundant power supplies further enhance the robustness of the synchronization solution. The open design of the HP 55400A allows the units to be integrated into high-level network administration solutions. An optional information management card supports local and remote system alarm reporting and performance monitoring.

Measuring and Monitoring Power Transmission Systems

Accurate fault location for large power transmission networks requires accurately synchronizing many points throughout the transmission system. The HP 59551A module provides a low-cost synchronization foundation for monitoring wide-area transmission systems, or for real-time monitoring and control. It includes capabilities suited to the synchronization requirements for power system analysis and optimization.

Time tagging, a standard feature of the HP 59551A, facilitates a variety of applications including fault location, network disturbance analysis, and detailed sequence-of-events analysis. Events can be time-stamped (with 100-nanosecond resolution), recorded, and downloaded to a computer system for review.



The HP 59551A GPS Measurements Synchronization Module

Input/output capabilities of the HP 59551A simplify its use with a variety of existing event and fault recorders. Standard functions include time tagging of conditioned TTL input signals, IRIG-B output, and an Alarm BITE output that indicates a system fault or loss of satellite lock. The low cost of the HP 59551A makes it practical to place one at each of the critical points in a power system. By synchronizing multiple points in the distribution network, reliable and meaningful field data can be collected and crucial system performance and operating characteristics can be extracted.

HP Technology: Enhancing Quartz Performance With HP SmartClock

Each of the HP GPS products combines affordable quartz oscillator platforms with HP SmartClock Technology, a breakthrough design for improved stability. The time base of Hewlett-Packard's GPS synchronization

products, the HP 10811D Quartz Oscillator, is a highly-reliable crystal component characterized by low sensitivity to temperature changes, low phase noise, and well-understood aging characteristics. Integrated with the quartz oscillator, the HP SmartClock algorithm improves the quartz-based system performance, making it equal to or better than a rubidium-based solution. The algorithm compares the oscillator frequency with the GPS reference signal. By "learning" the aging behavior and the environmental effects on the

oscillator over time, HP SmartClock adjusts the oscillator output frequency accordingly and significantly improves accuracy.

Holdover Mode During GPS Signal Loss

In normal operation, the GPS reference signal determines the long-term stability of the quartz oscillator. In the unlikely event of satellite signal loss or interruption, HP SmartClock enters an intelligent holdover mode to maintain accuracy until the GPS reference is regained. In holdover mode, HP SmartClock Technology adjusts the oscillator output based on the most-recently-learned characteristics.

Long-Term Accuracy and Reliability

HP SmartClock Technology eliminates the need for frequent calibrations — its learning capabilities and the GPS reference source automatically ensure ongoing accuracy. This accuracy complements the field-proven reliability of the HP quartz-based oscillators that offer a Mean Time Between Failures (MTBF) of more than 500,000 hours.

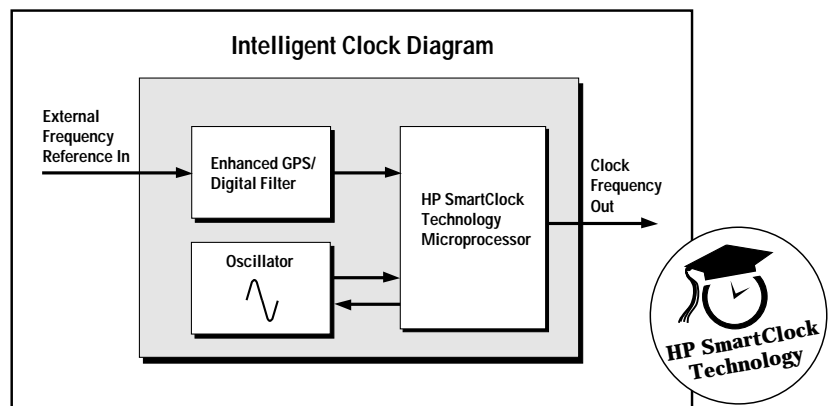

The HP SmartClock block diagram

GPS Glossary

Circular Error Probable (CEP)

— In a circular normal distribution (the magnitudes of the two one-dimensional input errors are equal and the angle of cut is 90 degrees), circular error probable is the radius of the circle containing 50 percent of the individual measurements being made, or the radius of the circle inside of which there is a 50 percent probability of a point being located.

Coordinated Universal Time (UTC)

— UTC, an atomic time scale, is the basis for civil time. It is occasionally adjusted by one-second increments to ensure that the difference between the uniform time scale, defined by atomic clocks, does not differ from the earth's rotation by more than 0.9 seconds.

Differential GPS — A technique used to improve radio navigation system accuracy by determining positioning error at a known location and subsequently transmitting the determined error, or corrective factors, to users of the same radio navigation system, operating in the same area.

Distance Root Mean Square (drms)

— The root-mean-square value of the distances from the true location point of the position fixes in a collection of measurements. As used in this document, 2 drms is the radius of a circle that contains at least 95 percent of all possible fixes that can be obtained with a system at any one place. Actually, the percentage of fixes contained within 2 drms varies between approximately 95.5 percent and 98.2 percent, depending on the degree of ellipticity of the error distribution.

Enhanced GPS — A method of digital filtering to reduce the effects of SA on a stationary receiver. Contributes to attaining high time accuracy.

Ephemeris — A table giving the coordinates of a celestial body at a number of specific times within a specific period.

Full Operational Capability (FOC) — For GPS, this is defined as the capability that occurs when 24 operational (Block II/IIA) satellites are operating in their assigned orbits and have been tested for military functionality and meet military requirements.

Geodesy — The science related to the determination of the size and shape of the earth (by such direct measurements as triangulation, leveling, and gravimetric observations) which determines the external gravitational field of the earth and, to a limited degree, the internal structure.

Geometric Dilution of Precision (GDOP) — All geometric factors that degrade the accuracy of position fixes derived from externally-referenced navigation systems.

Initial Operational Capability (IOC) — For GPS, this is defined as the capability that will occur when 24 GPS satellites (Block I/II/IIA) are operating in their assigned orbits and are available for navigation use.

Navigation — The process of planning, recording, and controlling the movement of a craft or vehicle from one place to another.

Spherical Error Probable (SEP)

— The radius of a sphere within which there is a 50 percent probability of locating a point. SEP is the three-dimensional equivalent of CEP.

Standard Deviation (sigma)

— A measure of the dispersion of random errors about the mean value. If a large number of measurements or observations of the same quantity are made, the standard deviation is the square root of the sum of the squares of deviations from the mean value divided by the number of observations less one.

Time Interval — The duration of a segment of time without reference to where the time interval begins or ends.

World Geodetic System (WGS)

— A consistent set of parameters describing the size and shape of the earth, the positions in a network of points with respect to the center of mass of the earth.

Abbreviations and Acronyms

1 pps	1 pulse per second	LOP	line of position
A-S	anti-spoofing	LORAN-C	most recent version of Long Range Navigation
BIPM	Bureau International des Poids et Mesures	MCS	Master Control Station
BPSK	binary phase shift keying	NAV-msg	navigation data message
C/A-code	coarse acquisition-code	P-Code	precise code
CEP	circular error probable	PDOP	position dilution of precision
CS	Control Segment	PPS	Precise Positioning Service
DGPS	Differential Global Positioning System	PRC	pseudorange corrections
DMA	Defense Mapping Agency	PRN	pseudorandom noise
DME	distance measuring equipment	PTTI	precise time and time interval
DoD	Department of Defense	SA	Selective Availability
DOP	dilution of precision	SEP	spherical error probable
DOT	Department of Transportation	SPS	Standard Positioning Service
drms	distance root mean squared	SV	Space Vehicle (satellite)
EGPS	Enhanced Global Positioning System	TDOP	time dilution of precision
FOC	full operational capability	TFOM	time figure of merit
FOM	figure of merit	TOA	time of arrival
FRP	Federal Radio Navigation Plan	UERE	user equivalent range error
GPS	Global Positioning System	URE	user range error
HDOP	horizontal dilution of precision	UTC	Universal Time Coordinated
IOC	initial operational capability	VDOP	vertical dilution of precision
L1	GPS primary frequency, 1575.42 MHz	WADGPS	Wide Area Differential GPS
L2	GPS secondary frequency, 1227.6 MHz	WGS-84	World Geodetic System (1984 update)
LADGPS	Local Area Differential GPS		

For more information on Hewlett-Packard Test and Measurement products, application or services please call your local Hewlett-Packard sales offices. A current listing is available via Web through AccessHP at <http://www.hp.com>. If you do not have access to the internet please contact one of the HP centers listed below and they will direct you to your nearest HP representative.

United States:

Hewlett-Packard Company
Test and Measurement Organization
5301 Stevens Creek Blvd.
Bldg. 51L-SC
Santa Clara, CA 95052-8059
1 800 452 4844

Canada:

Hewlett-Packard Canada Ltd.
5150 Spectrum Way
Mississauga, Ontario
L4W 5G1
(905) 206-4725

Europe:

Hewlett-Packard
European Marketing Centre
P.O. Box 999
1180 AZ Amstelveen
The Netherlands

Japan:

Hewlett-Packard Japan Ltd.
Measurement Assistance Center
9-1, Takakura-Cho, Hachioji-Shi,
Tokyo 192, Japan
(81) 426 48 3860

Latin America:

Hewlett-Packard
Latin American Region Headquarters
5200 Blue Lagoon Drive
9th Floor
Miami, Florida 33126
U.S.A.
(305) 267 4245/4220

Australia/New Zealand:

Hewlett-Packard Australia Ltd.
31-41 Joseph Street
Blackburn, Victoria 3130
Australia
131 347 ext 2902

Asia Pacific:

Hewlett-Packard Asia Pacific Ltd.
17-21/F Shell Tower, Time Square,
1 Matheson Street, Causeway Bay,
Hong Kong
(852) 2599 7070

For more information:
HP 58503A brochure
HP 59551A brochure

**Data Subject to Change
Printed in U.S.A. May 1996**

**Hewlett-Packard Company
Copyright © 1996
5965-2791E**