

# Universal Measuring Device UMG 96L

## Operating Instructions

Brief instructions see last page

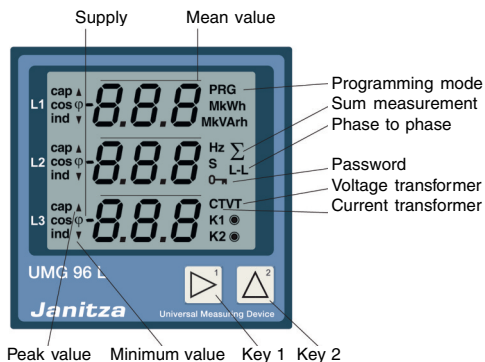

Janitza electronics GmbH  
Vor dem Polstück 1  
D-35633 Lahnau  
Support Tel. (0 64 41) 9642-22  
Fax (0 64 41) 9642-30  
e-mail: info@janitza.de  
Internet: http://www.janitza.de

**Janitza®**

## Table of contents

<b>The meaning of symbols</b>	<b>3</b>	<b>Uncertainty of measurement</b>	<b>26</b>
<b>Hints for the user</b>	<b>3</b>	<b>Configuration data</b>	<b>28</b>
<b>Receipt control</b>	<b>3</b>	<b>Declaration of conformity</b>	<b>29</b>
Contents of delivery	3	Safety guidelines	29
<b>Hints for maintenance</b>	<b>4</b>	Test voltage	29
Service	4	EMC requirements	29
<b>Product description</b>	<b>5</b>	<b>Technical data</b>	<b>30</b>
Intended use	5	Ambient conditions	30
Functional description	5	Measurement	30
<b>Installation</b>	<b>6</b>	Connectable cables	30
Mounting place	6	Dimensions	31
Measuring and operating voltage	6	Connection example	31
Current measurement	7	<b>Brief instructions</b>	<b>32</b>
Sum current measurement	7	Change current transformer ratio	32
Connecting options	8	Call up measured values	32
<b>Putting into service</b>	<b>10</b>		
Installation	10		
Attach measuring and operating voltage	10		
Connect measuring current	11		
Check phase assignment	11		
Check current direction	11		
Check measurement	11		
Check phase power	11		
Check sum power	11		
Elimination of errors	12		
Error messages	13		
<b>Usage and indication</b>	<b>14</b>		
Indication mode	14		
Programming mode	14		
Key functions	15		
Table, measured value indication	16		
Current transformer	18		
Voltage transformer	19		
Averaging times	20		
Measured value indication	21		
Measured value rotation time	21		
Measured value selection	22		
Delete minimum and maximum values	23		
Delete energy	23		
Working hours counter	24		
LCD contrast	24		
Software Release	25		
User password	25		

All rights reserved. No part of this manual may be reproduced or duplicated without the written permission of the author. Any contraventions are punishable and will be prosecuted with all legal means.

No liability can be taken for the faultless condition of the manual or damage caused by the use of it. As failures cannot be avoided completely, we shall be very grateful for any advice. We are anxious to remove all failures as soon as possible. The mentioned software and hardware descriptions are registered trademarks in the most cases and are subject to the regulations by law. All registered trademarks are property of the corresponding companies and are fully recognized by us.

### Issue Note

- 13.01.04 First Edition.
- 15.04.04 Measurement uncertainty.
- 27.03.06 Page 10/12 marking voltage measurement.
- 11.01.07 Page 9, Abb.5, 6 and 8 been cancelled.
- 12.04.07 Storage temperature -25°C.

## The meaning of symbols

The symbols, which are used in this manual, have the following meaning:



Beware of dangerous electrical voltage.



This symbol shall warn you about possible danger, which can occur during installation, putting into service and usage.

## Hints for the user

This device may be inserted and used by qualified personnel only according to the safety regulations. Please follow the legal and safety regulations for the corresponding application while using the device.

Qualified personnel are persons, who are familiar with installation, mounting, putting into service and operation of the product and have qualifications according to their occupation, for example:

- Education or instruction resp. the right to switch on or off, ground or characterize current circuits or devices according to the standards of safety techniques.
- Education or instruction in care and use of safety equipment according to the standard safety techniques.



### Attention!

If the device is not used according to this manual, a safe use cannot be granted, and the instrument might cause danger.



### Attention!

If a UMG 96L is installed in panels of metal, the panel must be earthed.

## Receipt control

In order to ensure a perfect and safe use of the device, a proper transport, expert storage, erection and mounting and careful usage and maintenance is required. In case that a safe operation can no longer be granted, the device has to be put out of service and has to be protected against unintentional putting into service.

A safe operation can no longer be assumed, if the device

- shows visible damage,
- does not work in spite of intact net supply,
- has been exposed to disadvantageous conditions for a longer time (e.g. storage beyond allowed climate without adaption to the room climate, dew etc.) or transport use (e.g. falling from great height, even without visible damage).

Please test the contents of delivery for completion, before starting the installation of the device.

### Contents of delivery

- 1 pc. UMG96L,
- 2 pcs. fixing brackets,
- 1 pc. manual.

As an option, a seal with part no. 29.01.907 can be delivered.

All delivered options and versions are listed on the delivery papers.



This manual also describes options, which have not been delivered and do not belong to the contents of delivery.

## Hints for maintenance

Before delivery the device is tested in various safety checks and marked with a seal. If the device is opened, these checks must be repeated.

For instruments, which are opened outside the manufacturing works, no warranty is granted whatsoever.

### Repairing and calibration

Repairing and calibration work can be carried out in the manufacturing works only.

#### Front foil

The cleaning of the front foil has to be effected with a soft cloth using a common cleansing agent. Acid or acidic agents are not allowed for cleaning.

### Waste management

The UMG96L can be disposed and recycled as electrical waste according to the legal regulations.

## Service

If there are questions, which are not described in this manual, please contact us directly.

For an efficient handling we need the following information:

- Description of device (see type plate),
- Serial digit (see type plate),
- Software Release,
- Measuring and operating voltage and
- detailed description of error.

You can reach us:

Monday until Thursday

between 07:00 and 15:00

and Friday

between 07:00 and 12:00

Janitza electronics GmbH

Vor dem Polstück 1

D-35633 Lahnau

Support: Tel. **(0 64 41) 9642-22**

Fax (0 64 41) 9642-30

e-mail: [info@janitza.de](mailto:info@janitza.de)

Internet: <http://www.janitza.de>

# Product description

## Intended use

The UMG96L is suitable for fix mounting and the measurement of voltage, current, power etc. in low voltage switchgear. The measurement is designed for 3 phase systems with neutral conductor (TN and TT-mains).

The UMG96L is suitable for mounting in fix and weather protected panels. Conducting panels must be earthed.

Due to the high resistance against interference, the UMG 96L is suitable for continuous and unsupervised operation.

As the UMG96L receives its power from phase L1 of the measuring voltage, at least phase L1 and the neutral conductor N must be connected.

The attached voltage must be within the range of the measuring and operation voltage shown on type plate.

Either ..../5A or ..../1A current transformers can be connected to the current measuring inputs.

The connection of the measuring and operating voltage is carried out on the back side of the UMG96L via all-insulated spring power clamps.

The measuring and operating voltages must be connected to the UMG 96L via a separation (switch or power switch) and an overcurrent protection fuse (2-10A) in the building installation. The separation (switch or power switch) must be near the UMG 96L and easily accessible.

## Functional description

The electronic three phase measurement system determines and digitalizes the effective values of voltages and currents in 50/60 Hz networks.

The operating voltage for operation of UMG96L is generated by the measuring voltage L1-N. A random test measurement is carried out each second at all current and voltage inputs. Measuring signal interruptions, which last longer than one second are safely recognized.

For each random test one period is scanned. From those sampled values the microprocessor calculates the electric quantities. These measured values are indicated within the programmable display. The energy as well as the minimum and maximum values are stored every 15 minutes whereas the programmed data are stored immediately in a non-volatile memory (EEPROM).

The scanning frequency for all measuring inputs is calculated from the net frequency of phase 1. At a net frequency of 50Hz the scanning frequency is 2,5kHz and for 60Hz it is 3,0kHz.

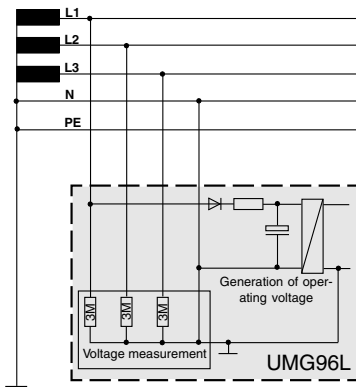

Diagr. Generation of the operating voltage from measurement voltage.

# Installation

## Mounting place

The UMG96L is suitable for a fix insertion into low and medium voltage switchgear. Any mounting position is possible.

## Measuring and operating voltage

The operating voltage of the UMG96L is generated by the measuring voltage. The measurement is designed for three phase systems with neutral conductor (TN and TT mains). The measuring and operating voltages must be connected to the UMG 96L via a separation (switch or power switch) and an overcurrent protection (2-10A) within the building installation. The connection of the measuring and operating voltages is carried out at the back side of the UMG 96L via shock protected spring clamps.

### 230V/400V Standard version

Phase L1 and the neutral conductor N must be connected, and the attached voltage must be within the range of the measuring and operating voltage.

### 120V/220V Special version

Phase L1 and the neutral conductor N must be connected, and the attached voltage must be within the range of the measuring and operating voltage.

### 60V/110V Special version

Phase L1 and the neutral conductor N must be connected, and the attached voltage must be within the range of the measuring and operating voltage.

- The connection wires for the operating voltage leading to the UMG96L must be suitable for voltages up to 300V against ground.

- The measuring and operating voltage has to be protected by a fuse, which must be in the range of **2A to 10A**.

- A switch or power switch for the operating voltage must be provided within the building installation.

- The switch has to be near the instrument and easily accessible.

- The switch must be marked as separation for this instrument.



#### Attention!

The limits indicated in the technical data may not be exceeded, not even while checking and putting into service of the UMG 96L.



#### Attention!

Before the device is connected to voltage for the first time, it should be deposited the installation room for at least 2 hours, to create a temperature assimilation and avoid condensation and dew.

## Current measurement

The current measurement is carried out via  $\dots/5A$  or  $\dots/1A$  current transformers. In case that the current has to be measured by an Amperemeter in addition to the UMG96L, the Amperemeter has to be connected in series to the UMG96L.

In mains with voltage up to 300VAC against ground, currents up to 5A can be connected and measured directly to the UMG 96L.

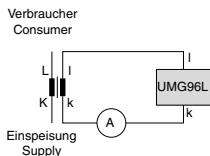

*Diagr. Connection example: UMG96L with Amperemeter in series.*

## Inaccuracy

The inaccuracy of the current measuring input is  $\pm 1\%$  of the measuring range (5A). Therefore, the inaccuracy of the current measurement is  $\pm 50mA$ .

### Example: Inaccuracy

With a current transformer 200/5A, the measuring range is 200A. The inaccuracy is  $\pm 1\%$  of 200A =  $\pm 2A$ .

## Resolution

The maximum resolution of the current measuring inputs is 10mA. The indication changes in 0.01A steps.

### Example: Resolution current transformer 200/5A

With a current transformer ratio of 200/5A, a resolution of  $10mA \cdot 40 = 400mA$  is effected. The display changes in 0.4A steps.

## Small currents

The minimum working current is 20mA. At short circuited or open current measurement input, the UMG 96L can indicate a small current. This current is within the range of the allowed measurement inaccuracy.

## Sum current measurement

If the current measurement is carried out via two current transformers, the total transformer ratio must be set to the UMG96L.

### Example: Sum current transformer

A current measurement is carried out via one current transformer with a ratio of 1000/5A and another one with a ratio of 200/5A. The sum measurement is carried out with a sum transformer 5+5/5A.

The UMG96L has to be programmed as follows:

Primary current:  $1000A + 200A = 1200A$   
Secondary current: **5A**

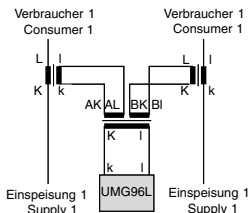

### Attention!

Current transformers may not be handled in open condition of the secondary, as the secondary clamps can lead live voltage.



### Attention!

Prior to connecting or exchanging the UMG 96L, the secondary clamps of the external current transformers have to be short circuited.



### Attention!

The program allows current and voltage transformer ratio setting only, if the maximum phase power can reach up to 50.0MW and the sum power can reach a maximum value of 150.0MW.

## Connecting options

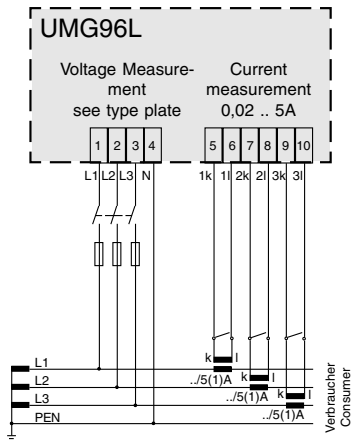

Diagr.: Connection example 1  
Four wire measurement with three current transformers

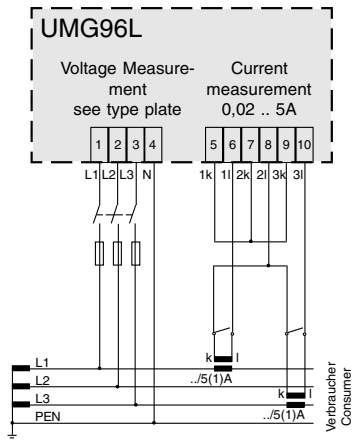

Diagr.: Connection example 2. Four wire measurement with two current transformers.

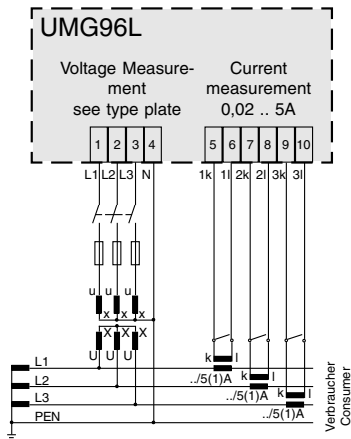

Diagr.: Connection example 3  
Measurement with three voltage transformers and three current transformers.

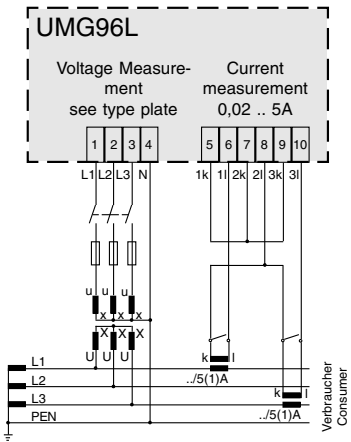

Diagr.: Connection example 4  
Measurement with three voltage transformers and two current transformers.



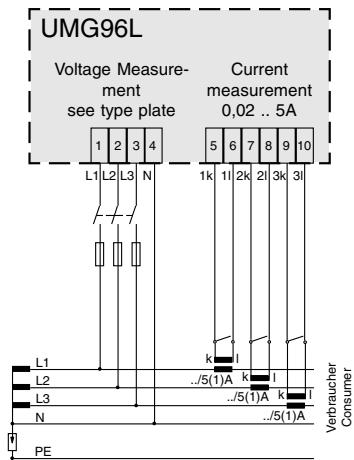

*Diagr.: Connection example 7  
Measurement in **IT networks** via three current  
transformers.*

## Putting into service

The putting into service of the UMG 96L should be carried out as follows:

### Installation

The UMG96L is designed for mounting in low voltage distributions, which contain overvoltage in measurement category III. The UMG96L is suitable for installation in fixed and weather proof panels. Conducting panels must be earthed. Any mounting position is possible. For mounting on front panels or doors, the delivered fixing brackets have to be used.

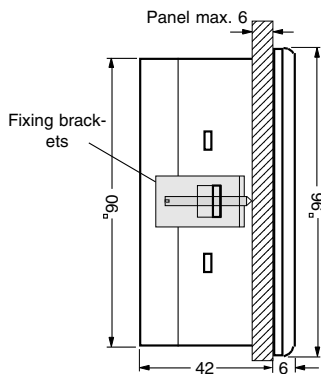

Diagr. Side view

### Attach measuring and operating voltage

The allowed measuring and operating voltage of UMG 96L is indicated on the type plate.



### Attention!

Measuring and operating voltage, which do not correspond to the indication on the type plate, can lead to malfunction and damage of the instrument.

The connection wires for measuring voltage leading to the UMG96L must be suitable for voltages up to 300V against ground and 520V phase to phase.

After connecting the stated measuring and operating voltage to the UMG 96L, all segments of the display appear. After approx. two seconds, the UMG 96L switches to the first measured value indication.

In case that no indication appears, please check, if the attached operating voltage is within the rated voltage range.

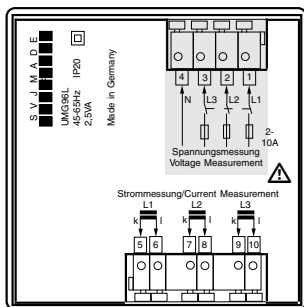

### Program current and voltage transformers

When the device leaves the manufacturer, a current transformer of 5/5A is set.

The set voltage transformer ratio has to be changed only, if a voltage transformer is connected.

When connecting voltage transformers, please observe the allowed measuring and operating voltage stated on type plate!

### Connect measuring current

The UMG96L is designed for the connection of  $\dots/1A$  and  $\dots/5A$  current transformers. With the current inputs, only alternating current but no direct current can be measured.



#### Attention!

Current transformers may not be handled in open condition, as there might be live voltage at the secondaries.

Please connect the current inputs one after the other, and compare the indicated current of the display with the actual current. Please note, that the current transformer ratio is set to 5/5A and has to be adapted to the existing current transformers.

In case that the current transformer is short circuited on the secondary, the indicated current at the corresponding conductor at UMG 96L has to decrease to a value, that corresponds to the secondary current plus tolerance. The current indicated by UMG 96L, has to conform to the input current, under consideration of the current transformer and tolerance.

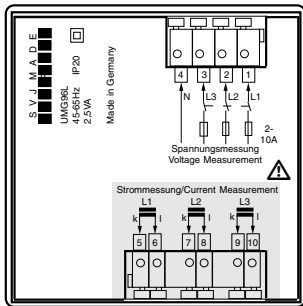

### Check phase assignment

The assignment of the outer conductors to the current transformer is correct, if a current transformer is short circuited on the secondary, and the indicated current in the corresponding phase decreases to a value at the UMG96L, which corresponds to the secondary current plus tolerance.

### Check current direction

Short circuit two current transformers on the secondary. The real power in the connected phase has to be:

Positive (+) for consumption of real power and negative (-) for supply of real power (power station service).

In case that no real power is indicated, the assignment of voltages and currents may be wrong.

### Check measurement

Provided that all voltage and current inputs are connected correctly, the phase and sum power is calculated and displayed correctly.

### Check phase power

In case that a current transformer is assigned to the wrong outer conductor, the corresponding power is measured and indicated incorrectly.

The assignment of the outer conductor and current transformer is correct, if no voltage is measured between the outer conductor and the primary of the corresponding current transformer.

To ensure that the outer conductor at the voltage input is assigned to the right current transformer, please short circuit the secondary of the corresponding current transformer. The apparent power of this phase at UMG 96L must be indicated by zero.

If the apparent power is indicated correctly, but the real power has a „-“ sign, the current transformer clamps are interchanged, or power is supplied to the energy supplier.

### Check sum power

Provided that all voltage, current and power in the corresponding phase is indicated correctly, the sum power must be displayed correctly by UMG 96L either.

For verification, the sum power measured by UMG96L should be compared to the energy stated by the real and reactive energy counters of the supplier.

## Elimination of errors

Error	Reason	Elimination
Display dark.	Prefuse released. Device defective.	Insert fuse. Send the device to the producer for repair.
Measured value cannot be called up.	The indication has been deleted from measured value selection.	Add the required measured value indication to the measured value selection.
No current indication.	Corresponding voltage is not connected.	Connect corresponding voltage.
Current too small.	Current measurement in wrong phase	Check and correct connection.
Current incorrect.	Current measurement in wrong phase Current transformer programmed incorrectly. Measuring range exceeded.	Check and correct connection.  Read ratio of current transformer and program accordingly. Insert a current transformer with a higher ratio.
	The current peak at measuring input was exceeded caused by harmonic waves.	Insert a current transformer with a higher ratio. Attention! Please ensure, that the measuring inputs are not overloaded. Insert a current transformer with a smaller ratio.
	The current at measuring input was below measuring range.	Check and correct connection.
Voltage L-N incorrect.	Measurement in wrong phase.  Voltage transformer ratio programmed incorrectly.	Check and correct connection.  Read the voltage transformer ratio at the voltage transformer and program accordingly.
Voltage L-L too small / too high.	Phase conductors interchanged.  N not connected.  Voltage transformer ratio programmed incorrectly.	Check and correct connection.  Check and correct connection.  Read voltage transformer ratio at the voltage transformer and program accordingly.

Error	Reason	Elimination
Phase shift ind/cap.	Current path is assigned to the wrong voltage path.	Check and correct connection.
Programmed data get lost.	The device was exposed to electro magnetical disturbance, which was higher than those mentioned in the technical data.	Improve external protection measures such as protection, filtering, earthing and local separation.
Real power too small / too high.	Current transformer ratio is programmed incorrectly. Current path is assigned to the wrong voltage path.	Read current transformer ratio and program accordingly. Check and correct connection.
Real power supply / consumption interchanged.	At least one current transformer connection is interchanged. Current path is assigned to the wrong voltage path.	Check and correct connection. Check and correct connection.
„Err“ in display.	See „error messages“	
The device does not operate in spite of the above.	Device defective.	Please send the device back to the producer with a detailed description of the error.

## Error messages

While exceeding an allowed measured value range, the UMG 96L indicates the error message „Err“.

An exceeding of a measured value range arises, if at least one of the three existing current or voltage inputs or the frequency is out of the specified measuring range.

The symbols "V", "A" and „Hz“ indicate, which measured value is out of range.

The phase is marked by the arrows upwards in which the exceeding occurred.

A = Current path  
V = Voltage path  
Hz = Frequency

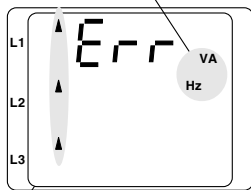

Exceeding of measuring range in phase L1/L2/L3



### Attention!

Voltage and current beyond the specifications may destroy the device.

## Usage and indication

The usage of the UMG96L is carried out via the keys one and two. Measured values and programming data are indicated on the liquid crystal display. You must distinguish between

Indication mode and  
Programming mode.

By entering a password, you can avoid unintentional change of programming data.

### Indication mode

In indication mode please scroll through the programmed measured value indications by using the keys 1 and 2. When the device is delivered, you can call up all measured values shown in table 1. For each measured value indication, up to three measured values are indicated. The measured value rotation allows to indicate all selected measured values on an alternate basis with a selectable changing time.

### Programming mode

In programming mode the settings, which are necessary for the operation of the UMG96L, can be indicated and changed. Pressing the keys 1 and 2 simultaneously for about 1 second, you reach programming mode via the password indication. If no user password is programmed, you reach the first programming menu directly. The programming mode is marked with the text „PRG“ in the display. With key 2 you can shift between the programming menus.

If you are in the programming mode and no keys are pressed for 60 seconds, or you press the keys 1 or 2 simultaneously for approx. 1 second, you return to the indication mode.

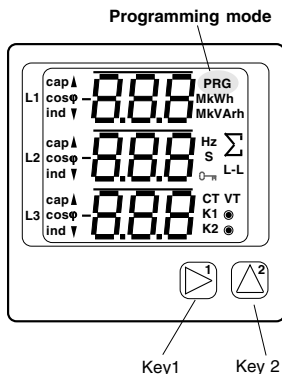

#### Programming menus:

- Current transformer,
- Voltage transformer,
- Averaging times,  
Measured value indications
  - Changing time,
  - Measured value selection,
  - Measured value rotation,
- Delete minimum and peak values,
  - Delete energy,
  - LCD contrast,
  - Software Release,
  - User password.

## Key functions

	Indication mode	Password	Programming mode
Change mode	<p>simultaneous</p>		
Scroll			
Programming			<p>Programming menu  Confirm selection</p> <p><b>8</b>  short digit +1 long digit -1</p> <p><b>8.8.8</b>  short value *10 (decimal point to the right)  long value /10 (decimal point to the left)</p> <p>flashing</p>

## Table, measured value indication

Measured values L1-N Voltage L2-N Voltage L3-N Voltage		Maximum values L1-N Voltage L2-N Voltage L3-N Voltage	Minimum values L1-N Voltage L2-N Voltage L3-N Voltage
Measured values L1-L2 Voltage L2-L3 Voltage L3-L1 Voltage		Maximum values L1 Real power L2 Real power L3 Real power	Minimum values L1 Real power L2 Real power L3 Real power
Measured values L1 Current L2 Current L3 Current	Mean values L1 Current L2 Current L3 Current	Maximum values L1 Current L2 Current L3 Current	Max. values L1 Curr. mean val. L2 Curr. mean val. L3 Curr. mean val.
Measured value $\Sigma$ Current in N	Mean value $\Sigma$ Current in N	Maximum value $\Sigma$ Measured value current in N	Maximum values $\Sigma$ Mean value current in N
Measured values L1 Real power L2 Real power L3 Real power	Mean values L1 Real power L2 Real power L3 Real power	Maximum values L1 Real power L2 Real power L3 Real power	
Measured value sum real power	Mean value sum real power	Maximum value (Consumption) sum real power meas.	Maximum value (Consumption) sum real power, mean
Measured values L1 Apparent power L2 Apparent power L3 Apparent power	Mean values L1 Apparent power L2 Apparent power L3 Apparent power	Maximum values L1 Apparent power L2 Apparent power L3 Apparent power	
Measured value sum apparent power	Mean value sum apparent power	Maximum value sum meas. value apparent power	

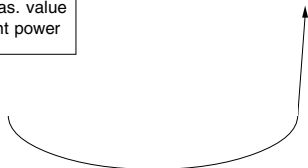



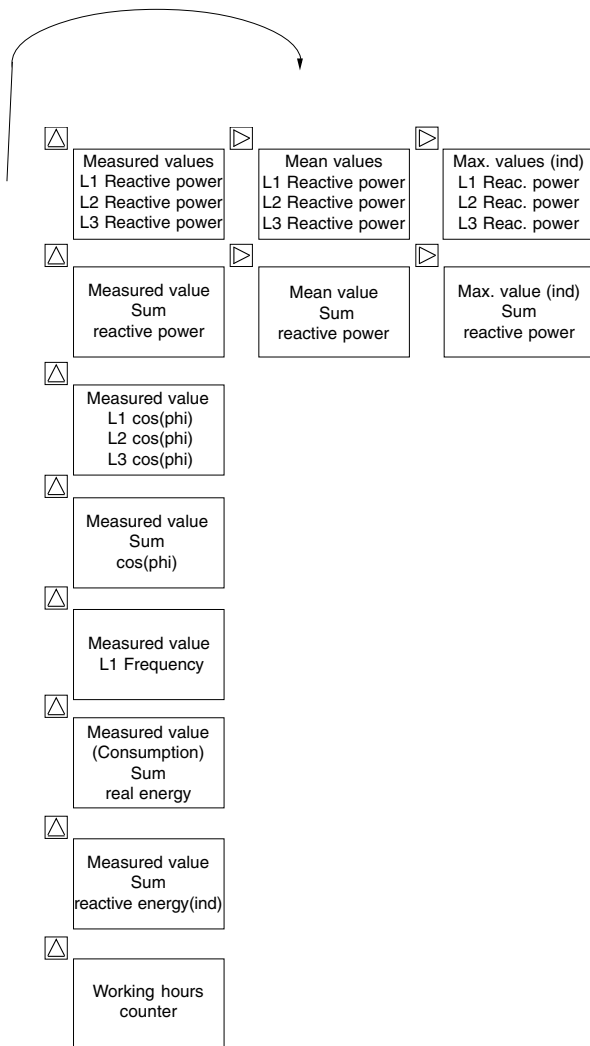

## Current transformer

Current transformers with either 1A or 5A secondary can be connected to the UMG96L.

A transformer ratio of 5A/5A is preset by the manufacturer. In programming mode the current transformer setting is marked by the symbol „CT“.

### Programming

In programming mode please scroll to the current transformer ratio by pressing key 2. Confirm the selection by pressing key 1.

The first digit of the primary current flashes and can be changed by pressing key 2.

If key 1 pressed again the next digit will be selected and flashes now.

If the entire digit flashes, the decimal point can be moved.

Press key 2 shortly - The decimal point moves to the right.

Press key 2 longer - The decimal point moves to the left.

If no digit flashes anymore, you can shift to the indication of the voltage transformer.

**Primary** (5.00kA = 5000A)

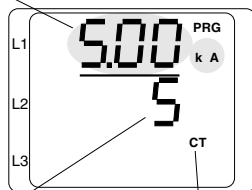

**Secondary**

Current transformer symbol

### Example: Sum current transformer

A current measurement is carried out via two current transformers, one with a ratio of 1000/5A and another transformer with a ratio of 200/5A. The sum measurement is carried out with a sum current transformer 5+5/5A.

The UMG96L has to be programmed with the following values:

Primary current:  $1000\text{A} + 200\text{A} = 1200\text{A}$

Secondary current: **5A**



### Attention!

The program allows current and voltage transformer ratio setting only, if the maximum phase power can reach up to 50.0MW and the sum power can reach a maximum value of 150.0MW.

## Voltage transformer

The phase to phase voltage (L-L) is indicated on display of the UMG 96L as secondary and primary voltage. The transformer ratio is calculated from the programmed primary and secondary voltage. In programming mode, the voltage transformer settings are marked by the symbol „VT“.

The standard version is preset by the manufacturer with a ratio of 400V/400V.

The **secondary voltage** is always indicated in „V“. The corresponding symbol „V“ is **not** displayed.

The **primary voltage** is indicated in „V“ or „kV“. The corresponding symbol is displayed in „V“ or „kV“.

### Primary voltage

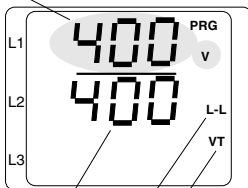

### Secondary voltage

Phase to phase  
Voltage transformer ratio

UMG96L		Setting range voltage transformer	
Version	Type plate	L-L secondary	L-L primary
<b>Standard version</b>	<b>196 .. 255V</b>	<b>400V</b>	100V .. 60kV ( <b>400V</b> )
Special version	90 .. 160V	<b>200V</b> , 220V	100V .. 60kV ( <b>200V</b> )
Special version	45 .. 80V	<b>100V</b> , 110V	100V .. 60kV ( <b>100V</b> )

## Programming

In programming mode, please scroll to the voltage transformer setting by pressing key 2. Confirm selection with key 1.

The first digit of the primary voltage flashes and can be changed by pressing key 2.

If key 1 is pressed again the next digit will be selected and flashes.

If the entire digit flashes, you can move the decimal point.

If no digit flashes anymore, you may shift to indication and programming of the outputs by pressing key 2.

### Primary voltage is 10,0kV

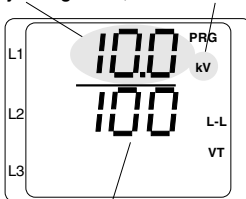

### Secondary voltage is 100V

Example: Voltage transformer ratio 100V/10kV



### Attention!

The program allows current and voltage transformer ratio setting only, if the maximum phase power can reach up to 50.0MW and the sum power can reach a maximum value of 150.0MW.

## Averaging times

A mean value is calculated for the most at the current and power values. A common averaging time for the current measured values L1, L2, L3 and N , as well as one for power measured values, real power, apparent power and reactive power is programmable.

Presettings:

Averaging time of currents = 900 seconds

Averaging time of power = 900 seconds

The following averaging times are selectable:  
5, 10, 30, 60, 300, 480, 900 seconds

## Method of taking the mean

The used exponential method reaches at least 95% of the measured value after the set averaging time.

$$ME_n = ME_{n-1} + (MA - ME_{n-1}) / N$$

$ME_n$  = indicated mean value

MA = measured value

n = consecutive digit

N = digit of measured values, of witch mean values shall be built.

## Programming of averaging time

### Averaging time for real power

In programming mode please scroll to the averaging time for power with key 2. Confirm selection by pressing key 1.

The averaging time flashes and can be changed by pressing key 2. Confirm changed averaging time with key 1.

The averaging time stops flashing. The averaging time for power has been programmed.

By using key 2 you can now shift to programming menu „Averaging time for current“.

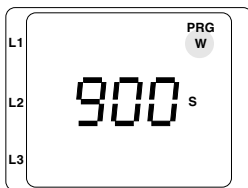

*Example for the averaging time of real power mean value, here 900 seconds.*

### Averaging time for Currents

In programming menu please scroll to the averaging time for currents. Confirm selection by pressing key 1.

The averaging time flashes and can be changed by pressing key 2. Confirm changed averaging time with key 1. The averaging time stops flashing. The averaging time for currents has been programmed. By using key 2 you can now shift to programming menu „Rotation time“.

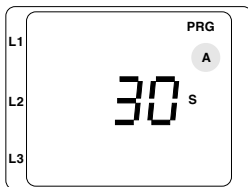

*Example for the averaging time of current mean value, here 30 seconds.*

## Measured value indication

Once in a second all measured values are calculated and can be indicated on the display. Two methods are available for calling up the measured value indications (see table 1).

- The selection of measured value indications via the keys 1 and 2, herein called **measured value selection**.

- The automatically rotating indications of selected measured value indications, herein called **measured value rotation**.

A **measured value rotation time** has been programmed additionally for the measured value rotation.

All measured values for the measured value selection are preset by the manufacturer. For the automatic rotation nothing is preset by the manufacturer. The rotation time is preset with 0 seconds.

## Measured value rotation time

Both methods are available simultaneously. The measured value rotation is programmed, if at least one measured value indication and one measured value rotation time bigger than 0 seconds is programmed. If no key is pressed for about 60 seconds, an automatic change to rotation mode will be carried out, and all programmed measured values will be indicated one after the other.

Setting range of measured value rotation time:  
0 .. 250 seconds

If 0 seconds are programmed, no rotation will be carried out. Nevertheless, measured value indications which are not programmed in the *measured value selection*, can be used for measured value rotation.

Rotation time in seconds indicated



Abb.

## Programming

In programming mode please scroll to the menu measured value rotation, by using key 2. Confirm selection with key 1.

The first digit of the rotation time flashes and can be changed by pressing key 2. By pressing key 1 again the next digit will be selected and flashes.

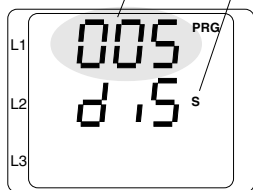
If no digit flashes anymore, you can shift to programming menu „Measured value selection“ by pressing key 2.

## Measured value selection

All measured values stated in table 1 (see page 16 and 17) can either be displayed via keep 1 and 2 **measured value selection** or automatically **measured value rotation**.

All measured values for the **measured value selection** are preset by the manufacturer. For the automatic **measured value rotation** nothing is preset by the manufacturer.

The condition of the selection is indicated by the output symbols. These symbols have the following meaning:

### Measured value selection

- **K1** The indication can be reached via the
- keys.
- **K1** The indication cannot be reached via keys.

### Measured value rotation

- **K2** The indication changes automatically.
- **K2** The indication does not change automatically.

## Programming

In programming mode please scroll to programming menu **measured value indication** by pressing key 2.

Confirm selection by pressing key 1.

The first measured value indicated stated in table 1 (see page 16 and 17) occurs.

A selection of the measured value indication is carried out by pressing the keys quickly.

Key 1 - Scroll to the right within the measured value indications.

Key 2 - Scroll downwards within the measured value indications.

For the selected measured value indication, it can now be determined whether it will be available for measured value selection and for automatic rotation.

The selection is carried out by an extended push on keys 1 or 2.

Key 1 - Measured value selection.

Key 2 - Automatic rotation.

Once the programming is finished, you return to indication mode by pressing keys 1 and 2 simultaneously.

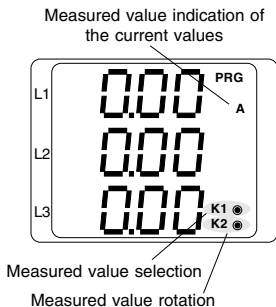
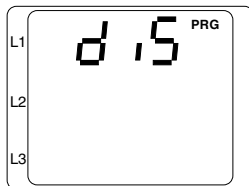

## Delete minimum and maximum values

In programming mode, „Deletion of minimum and maximum values“ is marked by arrows upwards and downwards. All minimum and maximum values will be deleted simultaneously in menu „Deletion of minimum and maximum values“.

An exception is the maximum value of the current mean value. The maximum value of the current mean value can also be deleted directly in indication menu by an extended pressing of key 2.

### Delete

In programming mode please scroll to *“Deletion of minimum and maximum values”* by pressing key 2.

With key 1 you can shift between the indicated digits 0 and 1. These digits have the following meaning:

- 0 = Minimum and maximum values **not** to be deleted.
- 1 = Minimum and maximum values to be deleted.

Leave menu “Deletion of minimum and maximum values” by pressing key 2. In case that digit 1 was displayed, all minimum and maximum values were deleted.

## Delete energy

The real and reactive energy can only be deleted together via the keys.

### Delete

In programming mode please scroll to the menu *“delete energy”* by using key 2.

By pressing key 1 you can shift between digits 0 and 1. These digits have the following meaning:

- 0 = Real and reactive energy **not** to be deleted.
- 1 = Real and reactive energy to be deleted.

Leave menu “Delete energy” by pressing key 2. In case that digit 1 was displayed real and reactive energy were deleted.

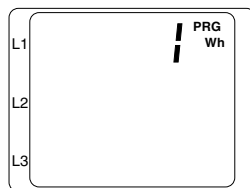
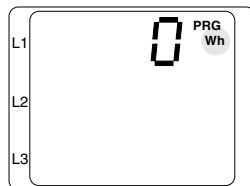
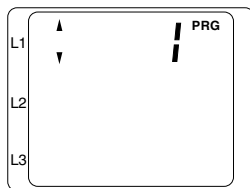
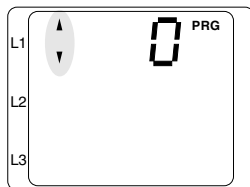

## Working hours counter

The working hours counter detects the time, in which the UMG96L measures and indicates data. The time is measured with a resolution of 15 minutes and is indicated in hours. The working hours counter cannot be deleted.

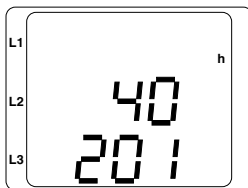

*Display example: The UMG96L indicates 40201 working hours.*

## LCD contrast

The favoured view for the LCD display is from below. The LCD contrast of the LCD display can be adapted by the user. The contrast setting is possible in the range from 0 to 7.

- 0 = very light
- 7 = very dark

## Programming

In programming mode please scroll to LCD contrast by pressing key 2. Confirm selection with key 1.

The first digit of the contrast setting is flashing. Move to the right digit with key 1. Now you can change the digit with key 2. Afterwards you can shift to programming menu „user password“ by pressing key 2.

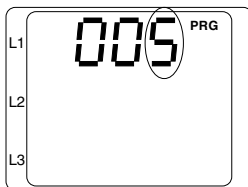
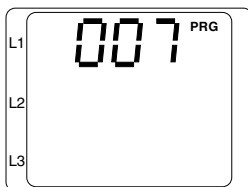



## Software Release

The internal software of the UMG96L will be improved and extended continuously. The software update is registered in the device by a specific number the so called software release. The software release cannot be changed by the user.



*Example: In UMG96L, the software release 1.23 is installed.*

## User password

A user password can be programmed in order to avoid an unintentional change of programming data. Only after entering the correct password, a shifting into the following programming menus possible.

No user password by the manufacturer is pre-set (000). In this case, the password menu will be skipped and you reach the current transformer menu directly.

In case that a user password was programmed, a „000“ appears in the display of the password menu.

The first digit of the password menu flashes and can be changed with key 2. By pressing key 1, the next digit will be selected and flashes.

Only after the correct password was entered, you reach the programming menu for the current transformer.

In case that a changed password is not known anymore, the device must be sent back to the manufacturer.

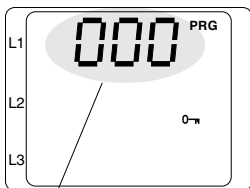

User password

## Uncertainty of measurement

Quantity	Indicating range	Measuring range <sup>1)</sup>	Measurement uncertainty <sup>2)</sup>
<b>Auxiliary voltage<sup>5)</sup> 196..255V</b>			
Voltage L-N	0 .. 34kV	50 .. 255V	+-1,5% rng
Voltage L-L	0 .. 60kV	87 .. 442V	+-2,0% rng
Current	0,00 .. 9,99kA	0,02 .. 6,00A	+-1,0% rng
Current in N	0,00 .. 9,99kA	0,06 .. 18,00A	+-3,0% rng
Real power, consumption, sum	0,00W .. 150MW	3,9W .. 3,825kW	+-1,5% rng
Real power, supply, sum	-0,00W .. -150MW	-3,9W .. -3,825kW	+-1,5% rng
Apparent power, sum	0,00VA .. 150MVA	3,9VA .. 3,825kVA	+-1,5% rng
Reactive power (Q0), sum	0,00var .. 150Mvar	3,9var .. 3,825kvar	+-1,5% rng
<b>Auxiliary voltage<sup>5)</sup> 90 .. 160V</b>			
Voltage L-N	0 .. 34kV	25 .. 160V	+-1,5% rng
Voltage L-L	0 .. 60kV	45 .. 277V	+-2,0% rng
Current	0,00 .. 9,99kA	0,02 .. 6,00A	+-1,0% rng
Current in N	0,00 .. 9,99kA	0,06 .. 18,00A	+-3,0% rng
Real power, consumption, sum	0,00W .. 150MW	1,8W .. 2,4kW	+-1,5% rng
Real power, supply, sum	-0,00W .. -150MW	-1,8W .. -2,4kW	+-1,5% rng
Apparent power, sum	0,00VA .. 150MVA	1,8VA .. 2,4kVA	+-1,5% rng
Reactive power (Q0), sum	0,00var .. 150Mvar	1,8var .. 2,4kvar	+-1,5% rng
<b>Auxiliary voltage<sup>5)</sup> 45 .. 80V</b>			
Voltage L-N	0 .. 34kV	16 .. 80V	+-1,5% rng
Voltage L-L	0 .. 60kV	28 .. 139V	+-2,0% rng
Current	0,00 .. 9,99kA	0,02 .. 6,00A	+-1,0% rng
Current in N	0,00 .. 9,99kA	0,06 .. 18,00A	+-3,0% rng
Real power, consumption, sum	0,00W .. 150MW	0,9W .. 1,2kW	+-1,5% rng
Real power, supply, sum	-0,00W .. -150MW	-0,9W .. -1,2kW	+-1,5% rng
Apparent power, sum	0,00VA .. 150MVA	0,9VA .. 1,2kVA	+-1,5% rng
Reactive power (Q0), sum	0,00var .. 150Mvar	0,9var .. 1,2kvar	+-1,5% rng
cos(phi)	0,00i .. 1.00 .. 0,00c		3)
Frequency (of voltage)	45,0 .. 65,0Hz		+-1,5% rdg
Reactive energy, inductive			
$\sqrt{\epsilon} < 10$	0..999 999 9.99kvarh		class 2 <sup>4)</sup>
$\sqrt{\epsilon} < 100$	0..999 999 99.9kvarh		class 2 <sup>4)</sup>
$\sqrt{\epsilon} \geq 100$	0..999 999 999kvarh		class 2 <sup>4)</sup>
Real energy, consumption			
$\sqrt{\epsilon} < 10$	0..999 999 9.99kWh		class 2 <sup>4)</sup>
$\sqrt{\epsilon} < 100$	0..999 999 99.9kWh		class 2 <sup>4)</sup>
$\sqrt{\epsilon} \geq 100$	0..999 999 999kWh		class 2 <sup>4)</sup>
Working hours counter	0..999 999 999h		+-2Min./Day



### Attention!

The program allows current and voltage transformer ratio setting only, if the maximum phase power can reach up to 50.0MW and the sum power can reach a maximum value of 150.0MW.

These specifications presuppose a yearly calibration and a warm up time of 10 minutes.  
Used abbreviations:

rng = of measuring range  
rdg = of measured value

- 1) Measuring range with scale factor = 1, (Current transformer = 5/5A, 1/1A)
- 2) In the range of -10..18°C and 28..55°C, an additional error of +0,5‰ of measured value has to be considered per K.
- 3) If the measured apparent power is in the range of 1% .. 100% of the measuring range,  $\cos(\phi)$  is indicated with an accuracy of +3%.
- 4) Accuracy class according to DIN EN61036:2001-01, VDE0418part 7, IEC61036:1996 + A1:2000
- 5) The auxiliary voltage is taken from the measuring voltage.
- 6) The maximum indication range and the resolution of real and reactive energy depends on

**Transformer ratio  $v = v_i \cdot v_u$ .**

**$v_i$**  = Transformer ratio of current transformer.

**$v_u$**  = Transformer ratio of voltage transformer.

Example:     200/5A ->  $v_i = 40$   
                   1000/100V ->  $v_u = 10$   
 $v = v_i \cdot v_u$   
 $v = 40 \cdot 10$   
 $v = 400$

Indication range and resolution for  
real and reactive energy

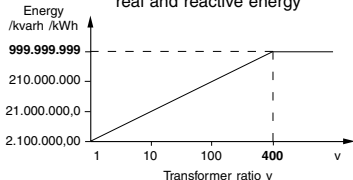

## Configuration data

Description	Display	Setting range	Presettings
Current transf., primary	<b>CT</b>	1A .. 10,0kA	5A
Current transf., secondary	<b>CT</b>	1A, 5A	5A
Voltage transf., primary			
Type plate, 196 .. 255V	<b>VT</b>	100V .. 60.0kV	<b>400V</b>
Type plate, 90 .. 160V	<b>VT</b>	100V .. 60.0kV	200V
Type plate, 45 .. 80V	<b>VT</b>	100V .. 60.0kV	100V
Voltage transformer, sec.			
Type plate, 196.. 255V	<b>VT</b>	400V (not changeable)	<b>400V</b>
Type plate, 90 .. 160V	<b>VT</b>	200V, 220V	200V
Type plate, 45 .. 80V	<b>VT</b>	100V, 110V	100V
Averaging time, current		5, 10, .. 900Sec.	900Sec.
Averaging time, power		5, 10, .. 900Sec.	900Sec.
Measured value rotation		0 .. 250seconds	0 = no rotation
Measured value selection		All indications	all indications
LCD contrast		0 .. 7	3
Software Release		not changeable	x.xx
User password	<b>0→</b>	000 .. 999	„000“ = no password
Working hours counter		not changeable	0h

## Declaration of conformity

The UMG96L fulfills the protection guidelines of:

**Guideline 89/336/EWG** in combination with **DIN EN61326 (2002-03)** as well as **Guideline 73/23/EWG** and **93/68/EWG** in combination with **EN 61010-1 (2002-08)**

## Safety guidelines

Safety requirements for electrical equipment for measurement, control, and laboratory use

Part1: General requirements : EN61010-1:2001, IEC 61010-1:2001

## Test voltage

Enclosure against measuring inputs : 2kV AC

Between the inputs for measuring and auxiliary voltage and the current inputs exists a functional separation of 2000V AC.

## EMC requirements

<b>Electromagnetic emission</b>	: DIN EN61326:2002-03, table 4, class B
<b>Electromagnetic immunity</b>	: DIN EN61326:2002-03, table A.1
Enclosure	: ESD test, IEC61000-4-2:2001 (4kV/8kV) : Electromagnetic RF-field, IEC61000-4-3:2002 (10V/m) : Netfrequent magnetic field, IEC61000-4-8:2000 (120A/m)
AC-power line	: AC-Power variation and dropout, IEC61000-4-11:2000 : Fast transients (Burst), IEC61000-4-4:2001 (2kV) : Powerful pulse (Surge), IEC61000-4-5:2000 (1kV L- N) : RF induced on lines, IEC61000-4-6:2000 (3V)
Current transformer inputs	: Fast transients (Burst), IEC61000-4-4:2001 (2kV) : Powerful pulse (Surge), IEC61000-4-5:2000 (1kV) : RF induced on lines, IEC61000-4-6:2000 (3V)

## Technical data

Weight	: 250g
Calorific value	: 2,2MJ (610Wh)
<b>Ambient conditions</b>	
Measurement category	: III (Measurement within building installation)
Pollution degree	: 2
Protection class	: II = with protective earth
Ambient temperature	: -10°C .. +55°C
Storage temperature	: -25°C .. +70°C
Humidity	: 15% up to 95% without dew
Protection class	
Front	: IP40 according to IEC60529
Front with seal (Option)	: IP42 according to IEC60529
Back side	: IP20 according to IEC60529
Mounting position	: random
Operating height	: 0 .. 2000m over sea level
<b>Measurement</b>	
<b>Measuring inputs</b>	
Measuring rate	: 1 measurement per second
Rated pulse voltage	: 4kV
Signal frequency	: 45Hz .. 1000Hz
Scanning frequency	: 2,5kHz/3,0kHz (Net frequency 50Hz/60Hz)
<b>Measuring and operating voltage</b>	: see type plate
Fuse	: 2A .. 10A (medium time lag type)
Frequency of fundamental	: 45Hz .. 65Hz
Power consumption Phase (L-N)	: ca. 0,1VA per phase.
<b>230V/400V Standard version</b>	
operating voltage	: 196 .. 255V AC
Range	: L-N 50V .. 255V, L-L 86V .. 442V
<b>120V/220V Special version</b>	
operating voltage	: 90 .. 160V AC
Range	: L-N 25V .. 160V, L-L 45V .. 277V
<b>60V/120V Special version</b>	
operating voltage	: 45 .. 80V AC
Range	: L-N 16V .. 80V, L-L 28V .. 139V
<b>Current measurement</b>	
Power consumption	: approx. 0,2VA
Rated current at .. /5A (../1A)	: 5A (1A)
Minimum working current	: 20mA
Current limit at .. /1A	: 1,2A (sinus shape)
Current limit at .. /5A	: 6A (sinus shape)
Overload	: 150A for 2 Sec.
<b>Accuracy class of energy measurement</b>	: class 2
<b>Connectable cables</b>	
One wire, multiple-wire, fine wire	: 0,08 - 2,5mm <sup>2</sup>
Pin contacts	: 1,5mm <sup>2</sup> , only one conductor may be connected per terminal!

## Dimensions

Cut out:  $92^{+0,8} \times 92^{+0,8}$  mm

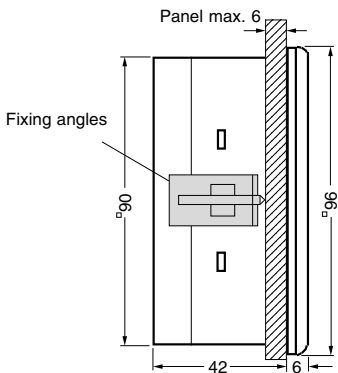

Diagr. Side view

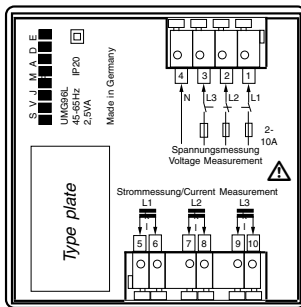

Diagr. Back view

All dimensions in mm

## Connection example

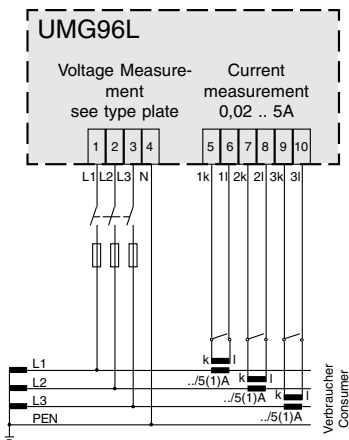

Diagr.: Connection example 1  
Four wire measurement with three current transformers.

## Brief instructions

### Change current transformer ratio

#### Shift to programming mode

If you are in the indication mode please press the keys 1 and 2 simultaneously for approx. 1 second. Now you reach programming mode.

The symbols for programming mode **PRG** and for the current transformer **CT** appear.

Confirm selection with key 1.

The first digit of the primary flashes.

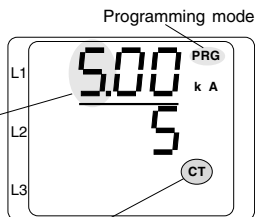

Current transformer symbol



#### Change primary current:

Change the flashing digit with key 2.

Select the next digit to be changed by pressing key 1.

The selected digit flashes.

If the entire number flashes, the decimal point can be moved.

Primary current

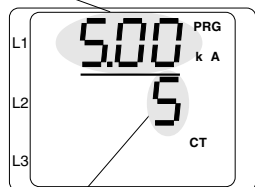

Secondary current



#### Change secondary current:

Only 1A or 5A can be set as secondary current.

Select secondary current with key 1.

Change flashing digit with key 2.

#### Leave programming mode:

Press both keys simultaneously for approx. 1 second.

The current transformer setting will be stored and you return to indication mode.

### Call up measured values

#### Shift to indication mode

If you are in programming mode please press the keys 1 and 2 simultaneously for approx. 1 second. Now you reach the indication mode.

The symbol **PRG** for programming mode does not appear in the display and the first measured value indication, e.g. for the voltage appears.

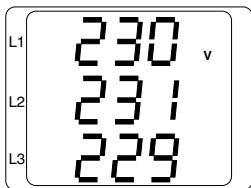

#### Key 2

With key 2 you scroll between the different measured value indications for current, voltage, power etc.

#### Key 1

With key 1 you scroll between the mean values, maximum values etc., related to the corresponding measured value.

