

**SPECIFICATIONS FOR  
LCD MODULE**

**Module No. JH24240320C**

E-mail: [sales@jhlcd.com](mailto:sales@jhlcd.com)

Website: [www.jhlcd.com](http://www.jhlcd.com)

## **TABLE OF CONTENTS**

### **LCM NUMBER SYSTEM**

<b>1.INTRODUCTION.....</b>	<b>.....</b>
<b>2.GENERAL SPECIFICATION.....</b>	<b>.....</b>
<b>3. MECHANICAL DRAWING.....</b>	<b>.....</b>
<b>4.ABSOLUTE MAXIMUM RATINGS.....</b>	<b>.....</b>
<b>5.ELECTRICAL CHARACTERISTICS.....</b>	<b>.....</b>
<b>6.TOUCH PANEL SPECIFICATIONS.....</b>	<b>.....</b>
<b>7.OPTICAL CHARACTERISTICS.....</b>	<b>.....</b>
<b>8.PIN ASSIGNMENT.....</b>	<b>.....</b>
<b>9.BLOCK DIAGRAM.....</b>	<b>.....</b>
<b>10.LCM QUALITY CRITERIA.....</b>	<b>.....</b>
<b>11.PACKING METHOD.....</b>	<b>.....</b>
<b>12.REVISION HISTORY.....</b>	<b>.....</b>

### **SAMPLE APPROVED REPORT**

JEWEL HILL

## LCM Number System

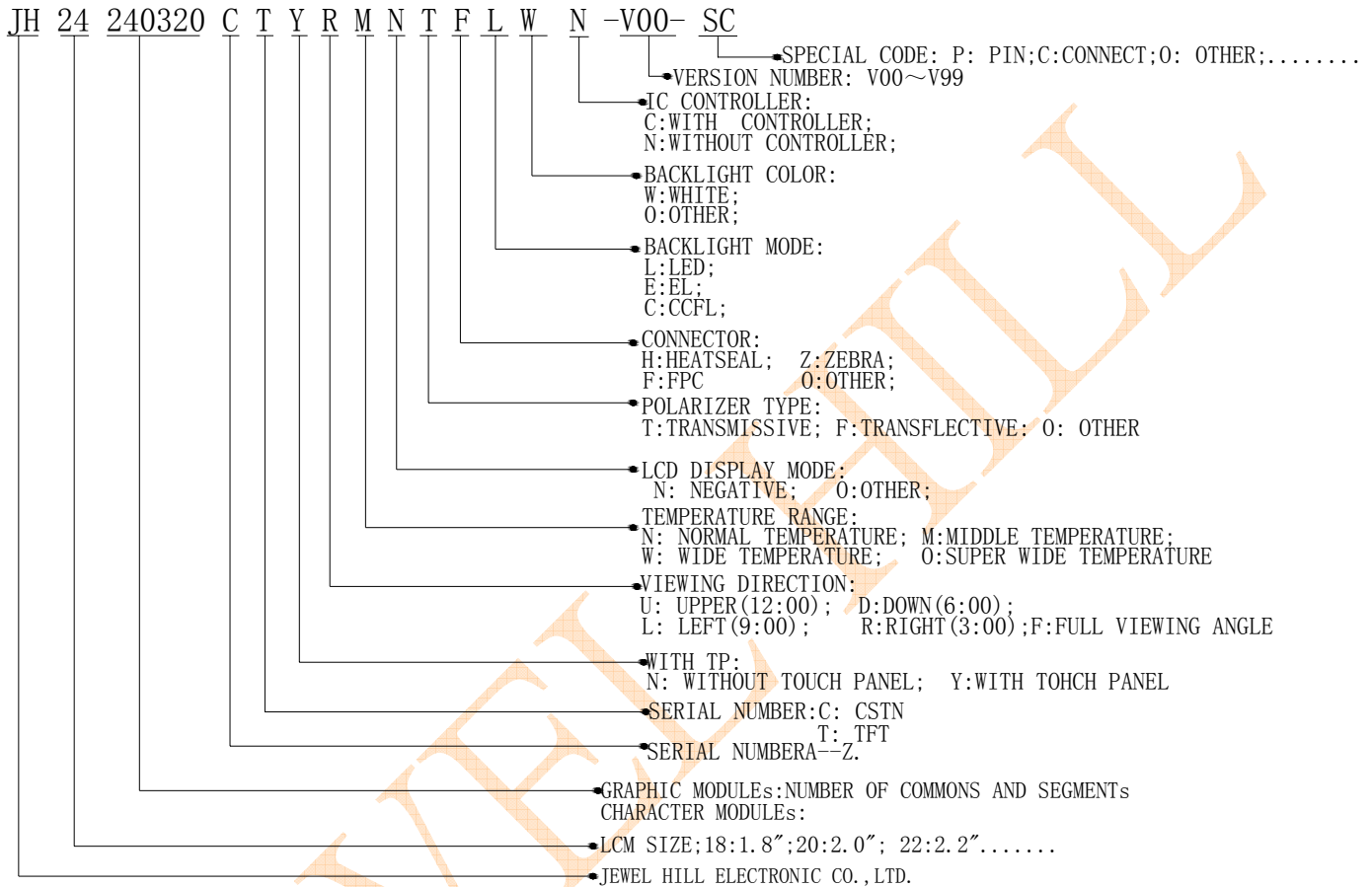

## **1. Introduction**

### **1.1 score of application**

This specification applies to the Negative type TFT transmissive dot matrix LCD module that is supplied by HongTai Technology CO.,LTD. This LCD module should be designed for mobile phone use.

LCD specification: Duty 1/320, Dots 240xRGBx320.

As to basic specification of the driver IC, refer to the IC (ILI9341) specification and datasheet.

### **1.2 .TFT Features:**

Structure: TFT PANNEL+IC+FPC+BL;

Transmissive Type LCD

240 dot-source and 320 dot-gate outputs;

65k or 262k Color can be selected by software;

White LED back light;

8/16 Bits parallel interface ;

### **1.3 Applications:**

Mobile phone

PSP

PDA

GPS

Etc...

## 2.General specification.

ITEM	Standard value	UNIT
LCD Type	TFT Negative Transmissive	---
Driver element	a-Si TFT Active matrix	
Number of Dots	240*(RGB)*320	Dots
Pixel Arrangement	RGB Vertical Stripe	
Dot Size (W*H)	<b>0.051X0.153</b>	mm
Dot Pitch (W*H)	<b>0.153X0.153</b>	mm
Active Area	<b>36.72*48.96</b>	mm
Viewing Area (W*H)	<b>38.72*53.16</b>	mm
LCD Duty	1/320	
LCD Bias	/	
Viewing Direction	3 0" clock	
Driver IC	ILI9341	
Module Size(W*H*T)	<b>42.72*60.26*3.5max</b>	mm
Approx. Weight	TBD	g
Back Light	White LED	
Touch Panel Type	-	
Touch Panel Active Area	-	mm
System interface	<b>8/16bits Paraller interface</b>	

JEWEL

### 3.Mechanical drawing

PIN	Symbol	PIN DESCRIPTION
1	GND	
2	YD	
3	XL	
4	YU	
5	XR	
6	LCD-ID	
7	VCC(2.8V)	
8	IOVCC(L, S/2, B)	
9	FMARK	
10	CS	
11	RS	
12	WR	
13	RD	
14-29	DB0-DB15	
30	RESET	
31	TMO	
32	NC	
33	GND	
34	LED-K1	
35	LED-K2	
36	LED-K3	
37	LED-K4	
38	LED-A	
39	GND	
40	NC	

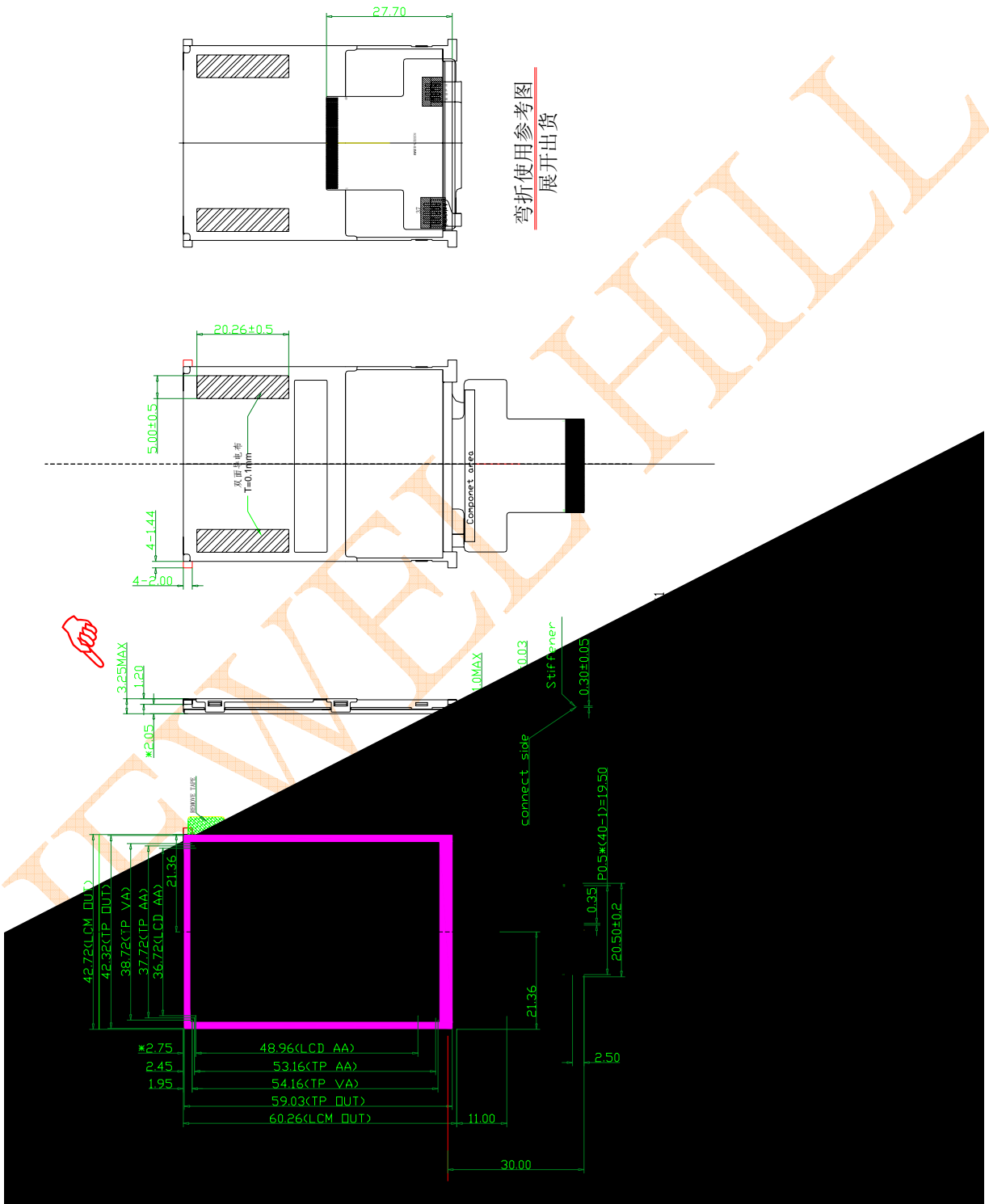

#### 4.ABSOLUTE MAXIMUM RATINGS

Parameter	Symbol	Min	Max	Unit
Supply voltage for logic	$V_{CC}$	-0.3	4.6	V
Input voltage for logic	$V_{IN}$	-0.3	4.6	V
Supply current (One LED)	$I_{LED}$		15	mA
Operating temperature	$T_{OP}$	-10	+60	°C
Storage temperature	$T_{ST}$	-20	+70	°C

#### 5.ELECTRICAL CHARACTERISTICS

Item	Symbol	Min	Typ	Max	Unit	Applicable terminal
Supply voltage for logic	$V_{CC}$	2.5	2.8	3.3	V	$V_{DD}$
Input voltage	$V_{IL}$	-0.3	-	0.2 $V_{DD}$	V	
	$V_{IH}$	0.8 $V_{CC}$	-	$V_{CC}$	V	
Input leakage current	$I_{LKG}$				μA	
LED Forward voltage	$V_f$	3.0	3.2	3.4	V	--
Input backlight current	$I_{LED}$	-	60	80	mA	

## 6. TOUCH PANEL SPECIFICATIONS.

### 6.1 Electrical Characteristics

ITEM	SPECIFICATIONS			UNIT	REMARK
	MIN.	TYP.	MAX		
Linearity	-1.5	-	1.5	%	After environment & life test
Terminal Resistance	200	-	650	ohm	X(Film side)
	350	-	800	ohm	Y(Glass side)
Insulation Resistance	10	-	-	Mohm	DC 25V 1min
Operating Voltage	-	5	-	V	DC

### 6.2 Optical Characteristics

ITEM	SPECIFICATIONS			UNIT	REMARK
	MIN.	TYP.	MAX		
Response Time	-	-	10	ms	100kohm pull-up
Light Transparency	80	-	-	%	

### 6.3 Mechanical Characteristics

ITEM	SPECIFICATIONS			UNIT	REMARK
	MIN.	TYP.	MAX		
Operation Force	-	20	50	gf	Note1
Surface Hardness	3	-	-	H	
Pen Sliding Durability	100,000			times	Note2
Hitting Durability	1,000,000			times	Note3

Note 1: Do not operate it with a thing except a polyacetal pen (tip R0.8mm or less) or a finger, especially those with hard or sharp tips such as a ball point pen or a mechanical pencil. Depending on the pitch & the dimension of the spacer dots in between.

Note 2: Measurement for surface area.

-Scratch 100,000 times straight line on the film with a stylus change every 20,000 times.

-Force: **100gf.**

-Speed: **60mm/sec.**

-Stylus: R0.8 polyacetal tip.

Note 3: Hit 1,000,000 times on the film with an **R12.5mm** tip.

-Force: 250gf.

-Speed: **2 times/sec.**

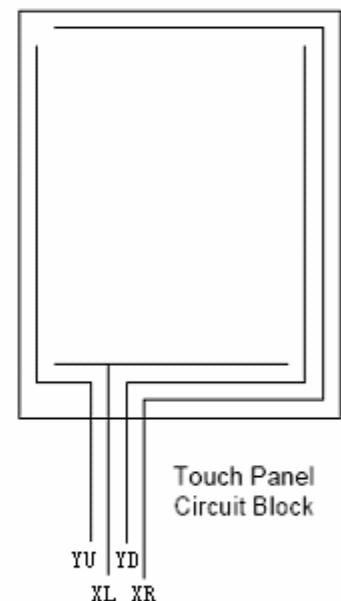



## 7.OPTICAL CHARACTERISTICS

ITEM	SYMBOL	CONDITIONS	SPECIFICATIONS			UNIT	NOTE	
			MIN.	TYP.	MAX			
Brightness	B	Viewing normal angle $\theta_x = \theta_y = 0^\circ$	180	240	--	Cd/m <sup>2</sup>	All left side data are based on CMO's product reference only	
Contrast Ratio	CR		300	350	--	--		
Response Time	Tr+Tf		--	20	30	ms		
CIE Color coordinate	Red		X <sub>R</sub>	--	0.621			
			Y <sub>R</sub>		0.329			
	Green		X <sub>G</sub>	--	0.292			
			Y <sub>G</sub>		0.562			
	Blue		X <sub>B</sub>	--	0.135			
			Y <sub>B</sub>		0.165			
White	X <sub>w</sub>		--	0.299				
	Y <sub>w</sub>		0.352					
Viewing Angle	Hor.	$\theta_{x+}$	40	45	--	Deg.		
		$\theta_{x-}$	40	45	--			
	Ver.	$\theta_{y+}$	45	50	--			
		$\theta_{y-}$	15	20				
Uniformity	Un		80	85		%		

Note 1 : Definition of Viewing Angle  $\theta_x$  and  $\theta_y$  :

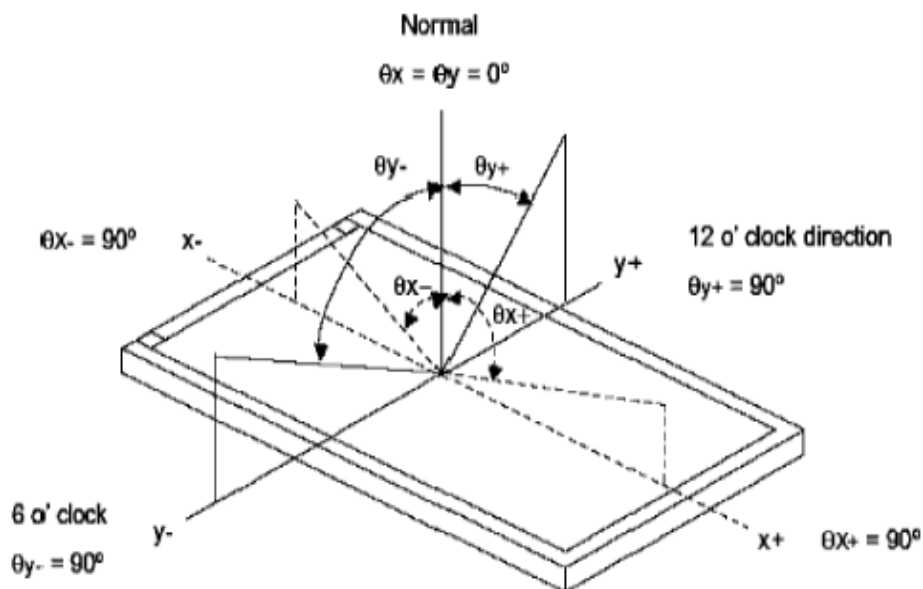

**Note 2: Definition of contrast ratio CR:**

$$CR = \frac{\text{Brightness of non-selected dots (white)}}{\text{Brightness of selected dots (black)}}$$

**Note 3: Definition of response time ( $T_R$ ,  $T_F$ )**

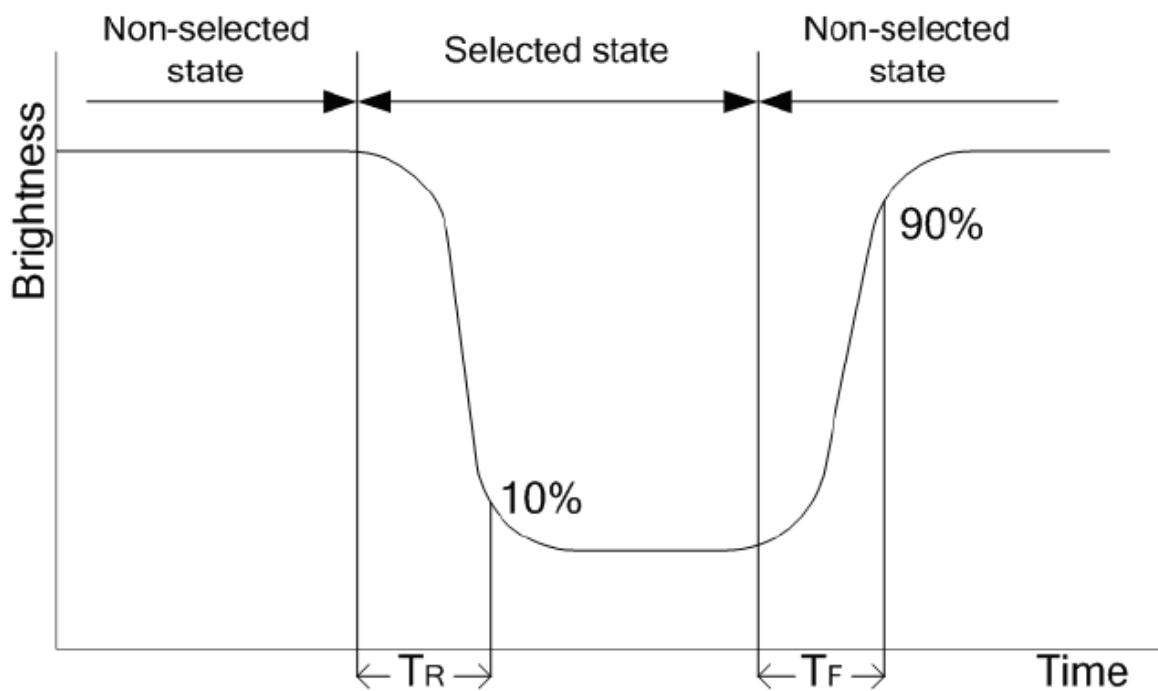

The brightness test equipment setup

20mA Field=2° (As measuring "black" image, field=2° is the best testing condition)

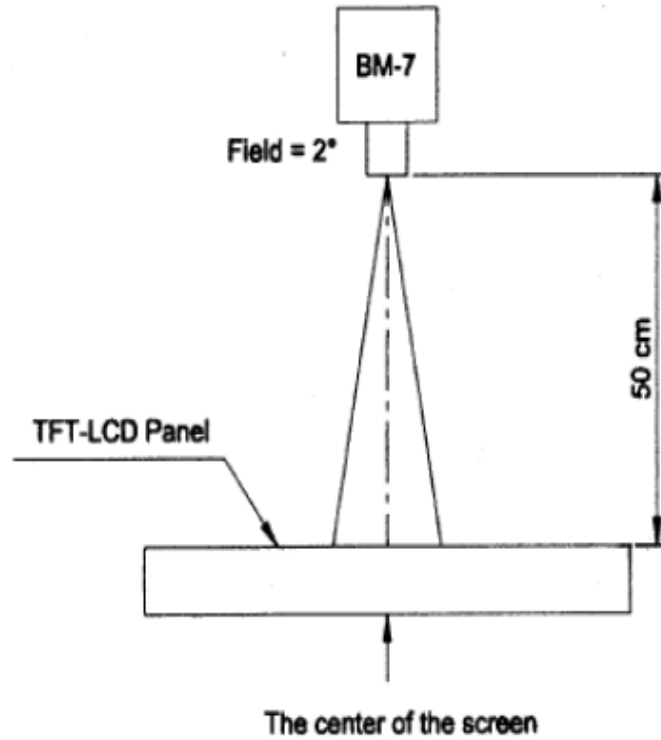

Note 4 :

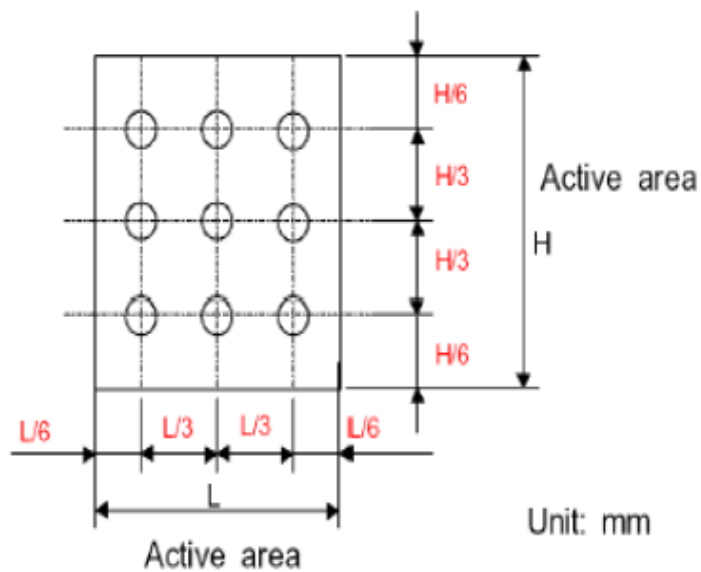

## 8.MCU Interface Pin Function

Pin NO.	Symbol	Description
1	GND	Power Ground
2	YD	TOUCH PANEL Y_ DOWN
3	XL	TOUCH PANEL X_ LEFT
4	YU	TOUCH PANEL Y_ UP
5	XR	TOUCH PANEL X_ RIGHT
6	LCD-IN	NC
7	VCC	The power supply 2.8V
8	IOVCC	Power supply For logic(1.8-2.8V)
9	FMARK(TE)	NC
10	CS	Chip Select
11	RS	Command/display data select pin
12	WR	Write signal
13	RD	Read signal
14-29	D0-D15	Data bus
30	RESET	Reset Pin
31	IM0	80 -16bits/80- 8bits select pin
32	NC	NC
33	GND	Power Ground
34	LEDK1	Backlight Power(cathode)
35	LEDK2	Backlight Power(cathode)
36	LEDK3	Backlight Power(cathode)
37	LEDK4	Backlight Power(cathode)
38	LEDA	Backlight Power(ande)
39	GND	Power Ground
40	NC	NC

**9. Block diagram**

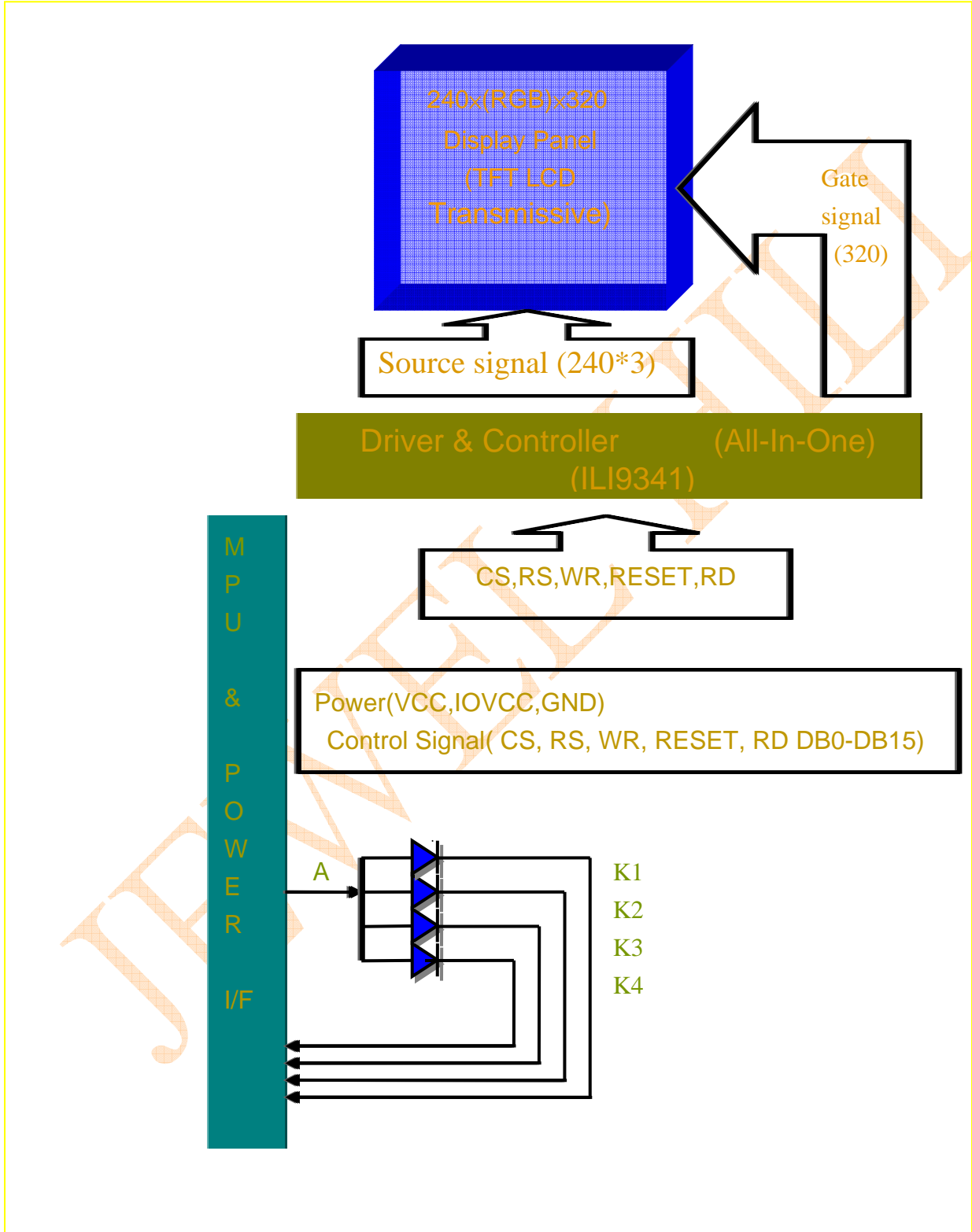

## 10.LCM Quality Criteria.

### 10.1 Visual & function inspection standard

#### 10.1.1 Inspection conditions

Inspection performed under the following conditions is recommended.

Temperature : 25±5℃

Humidity : 65%±10%RH

Viewing Angle : Normal viewing Angle.

Illumination: Single fluorescent lamp (300 to 700Lux)

Viewing distance:30-50cm

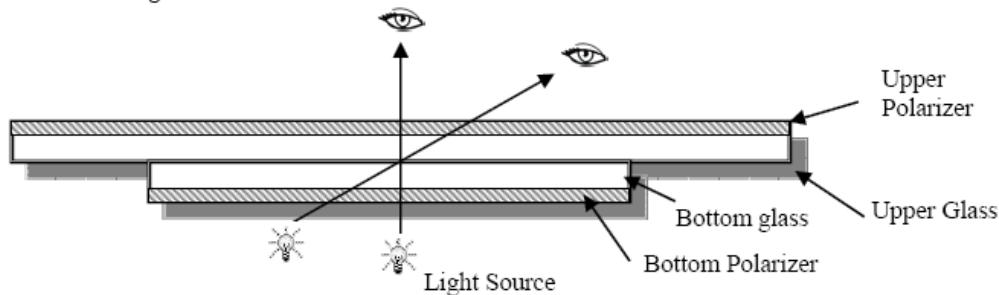

#### 10.1.2 Definition

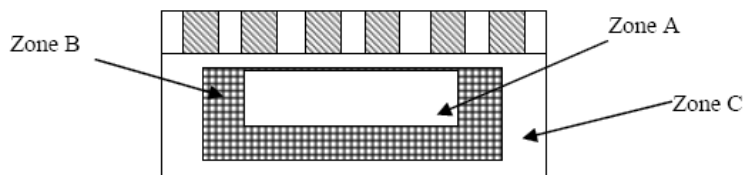

Zone A : Effective Viewing Area(Character or Digit can be seen)

Zone B : Viewing Area except Zone A

Zone C : Outside (Zone A+Zone B) which can not be seen after assembly by customer .)

Note:

As a general rule ,visual defects in Zone C can be ignored when it doesn't effect product function or appearance after assembly by customer.

#### 10.1.3 Sampling Plan

According to GB/T 2828-2003 ; , normal inspection, Class II

AQL:

Major defect	Minor defect
0.65	1.5

LCD: Liquid Crystal Display , TP: Touch Panel , LCM: Liquid Crystal Module

No	Items to be inspected	Criteria	Classification of defects
1	Functional defects	1) No display, Open or miss line 2) Display abnormally, Short 3) Backlight no lighting, abnormal lighting. 4) TP no function	Major
2	Missing	Missing component	
3	Outline dimension	Overall outline dimension beyond the drawing is not allowed	
4	Color tone	Color unevenness, refer to limited sample	Minor
5	Soldering appearance	Good soldering , Peeling off is not allowed.	

**10.1.4 criteria(Visual)**

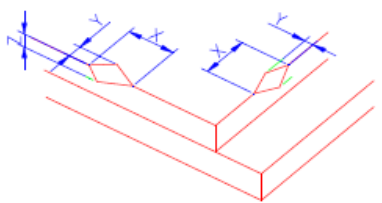
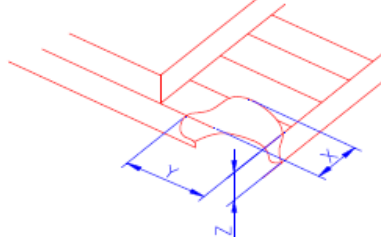
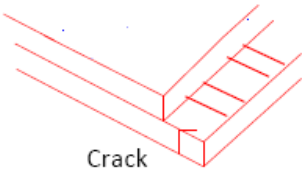
Number	Items	Criteria(mm)						
1.0 LCD Crack/Broken  NOTE: X: Length Y: Width Z: Height L: Length of ITO, T: Height of LCD	(1) The edge of LCD broken	 <table border="1" data-bbox="885 593 1420 750"> <thead> <tr> <th>X</th> <th>Y</th> <th>Z</th> </tr> </thead> <tbody> <tr> <td>≤3.0mm</td> <td>&lt;Inner border line of the seal</td> <td>≤T</td> </tr> </tbody> </table>	X	Y	Z	≤3.0mm	<Inner border line of the seal	≤T
X	Y	Z						
≤3.0mm	<Inner border line of the seal	≤T						
	(2)LCD corner broken	 <table border="1" data-bbox="949 1064 1364 1131"> <thead> <tr> <th>X</th> <th>Y</th> <th>Z</th> </tr> </thead> <tbody> <tr> <td>≤3.0mm</td> <td>≤L</td> <td>≤T</td> </tr> </tbody> </table>	X	Y	Z	≤3.0mm	≤L	≤T
X	Y	Z						
≤3.0mm	≤L	≤T						
	(3) LCD crack	 <p>Crack Not allowed</p>						

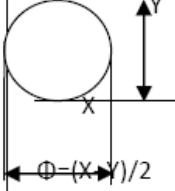
Number	Items	Criteria (mm)																																																																	
2.0	Spot defect 	<p>① light dot (LCD/TP/Polarizer black/white spot, light dot, pinhole, dent, stain)</p> <table border="1"> <thead> <tr> <th rowspan="2">Zone Size (mm)</th> <th colspan="3">Acceptable Qty</th> </tr> <tr> <th>A</th> <th>B</th> <th>C</th> </tr> </thead> <tbody> <tr> <td><math>\Phi \leq 0.10</math></td> <td colspan="3">Ignore</td> </tr> <tr> <td><math>0.10 &lt; \Phi \leq 0.15</math></td> <td colspan="3">3( distance <math>\geq 10\text{mm}</math>)</td> </tr> <tr> <td><math>0.15 &lt; \Phi \leq 0.2</math></td> <td colspan="3">1</td> </tr> <tr> <td><math>0.2 &lt; \Phi</math></td> <td colspan="3">0</td> </tr> </tbody> </table> <p>② Dim spot (LCD/TP/Polarizer dim dot, light leakage, dark spot)</p> <table border="1"> <thead> <tr> <th rowspan="2">Zone Size (mm)</th> <th colspan="3">Acceptable Qty</th> </tr> <tr> <th>A</th> <th>B</th> <th>C</th> </tr> </thead> <tbody> <tr> <td><math>\Phi \leq 0.1</math></td> <td colspan="3">Ignore</td> </tr> <tr> <td><math>0.1 &lt; \Phi \leq 0.2</math></td> <td colspan="3">2( distance <math>\geq 10\text{mm}</math>)</td> </tr> <tr> <td><math>0.2 &lt; \Phi \leq 0.3</math></td> <td colspan="3">1</td> </tr> <tr> <td><math>\Phi &gt; 0.3</math></td> <td colspan="3">0</td> </tr> </tbody> </table> <p>③ Polarizer accidented spot</p> <table border="1"> <thead> <tr> <th rowspan="2">Zone Size (mm)</th> <th colspan="3">Acceptable Qty</th> </tr> <tr> <th>A</th> <th>B</th> <th>C</th> </tr> </thead> <tbody> <tr> <td><math>\Phi \leq 0.2</math></td> <td colspan="3">Ignore</td> </tr> <tr> <td><math>0.2 &lt; \Phi \leq 0.5</math></td> <td colspan="3">2( distance <math>\geq 10\text{mm}</math>)</td> </tr> <tr> <td><math>\Phi &gt; 0.5</math></td> <td colspan="3">0</td> </tr> </tbody> </table>	Zone Size (mm)	Acceptable Qty			A	B	C	$\Phi \leq 0.10$	Ignore			$0.10 < \Phi \leq 0.15$	3( distance $\geq 10\text{mm}$ )			$0.15 < \Phi \leq 0.2$	1			$0.2 < \Phi$	0			Zone Size (mm)	Acceptable Qty			A	B	C	$\Phi \leq 0.1$	Ignore			$0.1 < \Phi \leq 0.2$	2( distance $\geq 10\text{mm}$ )			$0.2 < \Phi \leq 0.3$	1			$\Phi > 0.3$	0			Zone Size (mm)	Acceptable Qty			A	B	C	$\Phi \leq 0.2$	Ignore			$0.2 < \Phi \leq 0.5$	2( distance $\geq 10\text{mm}$ )			$\Phi > 0.5$	0		
Zone Size (mm)	Acceptable Qty																																																																		
	A	B	C																																																																
$\Phi \leq 0.10$	Ignore																																																																		
$0.10 < \Phi \leq 0.15$	3( distance $\geq 10\text{mm}$ )																																																																		
$0.15 < \Phi \leq 0.2$	1																																																																		
$0.2 < \Phi$	0																																																																		
Zone Size (mm)	Acceptable Qty																																																																		
	A	B	C																																																																
$\Phi \leq 0.1$	Ignore																																																																		
$0.1 < \Phi \leq 0.2$	2( distance $\geq 10\text{mm}$ )																																																																		
$0.2 < \Phi \leq 0.3$	1																																																																		
$\Phi > 0.3$	0																																																																		
Zone Size (mm)	Acceptable Qty																																																																		
	A	B	C																																																																
$\Phi \leq 0.2$	Ignore																																																																		
$0.2 < \Phi \leq 0.5$	2( distance $\geq 10\text{mm}$ )																																																																		
$\Phi > 0.5$	0																																																																		

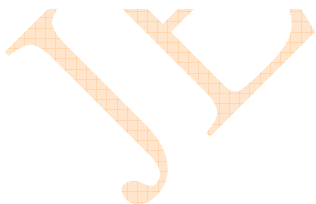







	Line defect (LCD/TP /Polarizer black/white line, scratch, stain)	<table border="1"> <tr> <th rowspan="2">Width(mm)</th> <th rowspan="2">Length(mm)</th> <th colspan="3">Acceptable Qty</th> </tr> <tr> <th>A</th> <th>B</th> <th>C</th> </tr> <tr> <td><math>\Phi \leq 0.03</math></td> <td>Ignore</td> <td colspan="3">Ignore</td> </tr> <tr> <td><math>0.03 &lt; W \leq 0.05</math></td> <td><math>L \leq 3.0</math></td> <td colspan="3">N<math>\leq</math>2</td> </tr> <tr> <td><math>0.05 &lt; W \leq 0.08</math></td> <td><math>L \leq 2.0</math></td> <td colspan="3">N<math>\leq</math>2</td> </tr> <tr> <td><math>0.08 &lt; W</math></td> <td colspan="4">Define as spot defect</td> </tr> </table>			Width(mm)	Length(mm)	Acceptable Qty			A	B	C	$\Phi \leq 0.03$	Ignore	Ignore			$0.03 < W \leq 0.05$	$L \leq 3.0$	N $\leq$ 2			$0.05 < W \leq 0.08$	$L \leq 2.0$	N $\leq$ 2			$0.08 < W$	Define as spot defect			
		Width(mm)	Length(mm)	Acceptable Qty																												
				A	B	C																										
		$\Phi \leq 0.03$	Ignore	Ignore																												
		$0.03 < W \leq 0.05$	$L \leq 3.0$	N $\leq$ 2																												
$0.05 < W \leq 0.08$	$L \leq 2.0$	N $\leq$ 2																														
$0.08 < W$	Define as spot defect																															
3.0	Polarizer Bubble	<table border="1"> <tr> <th rowspan="2">Zone Size (mm)</th> <th colspan="3">Acceptable Qty</th> </tr> <tr> <th>A</th> <th>B</th> <th>C</th> </tr> <tr> <td><math>\Phi \leq 0.2</math></td> <td colspan="3">Ignore</td> </tr> <tr> <td><math>0.2 &lt; \Phi \leq 0.4</math></td> <td colspan="3">2(distance <math>\geq</math> 10mm)</td> </tr> <tr> <td><math>0.4 &lt; \Phi \leq 0.6</math></td> <td colspan="3">1</td> </tr> <tr> <td><math>0.6 &lt; \Phi</math></td> <td colspan="3">0</td> </tr> </table>			Zone Size (mm)	Acceptable Qty			A	B	C	$\Phi \leq 0.2$	Ignore			$0.2 < \Phi \leq 0.4$	2(distance $\geq$ 10mm)			$0.4 < \Phi \leq 0.6$	1			$0.6 < \Phi$	0							
		Zone Size (mm)	Acceptable Qty																													
			A	B	C																											
		$\Phi \leq 0.2$	Ignore																													
		$0.2 < \Phi \leq 0.4$	2(distance $\geq$ 10mm)																													
$0.4 < \Phi \leq 0.6$	1																															
$0.6 < \Phi$	0																															
4.0	SMT	According to IPC-A-610C class II standard . Function defect and missing part are major defect ,the others are minor defect.																														
	TP bubble/ accidented spot	<table border="1"> <tr> <th rowspan="2">Size <math>\Phi</math>(mm)</th> <th colspan="3">Acceptable Qty</th> </tr> <tr> <th>A</th> <th>B</th> <th>C</th> </tr> <tr> <td><math>\Phi \leq 0.1</math></td> <td colspan="3">Ignore</td> </tr> <tr> <td><math>0.1 &lt; \Phi \leq 0.2</math></td> <td colspan="3">2</td> </tr> <tr> <td><math>0.2 &lt; \Phi \leq 0.3</math></td> <td colspan="3">(distance <math>\geq</math> 10mm)</td> </tr> <tr> <td><math>0.3 &lt; \Phi</math></td> <td colspan="3">0</td> </tr> </table>			Size $\Phi$ (mm)	Acceptable Qty			A	B	C	$\Phi \leq 0.1$	Ignore			$0.1 < \Phi \leq 0.2$	2			$0.2 < \Phi \leq 0.3$	(distance $\geq$ 10mm)			$0.3 < \Phi$	0							
		Size $\Phi$ (mm)	Acceptable Qty																													
A	B		C																													
$\Phi \leq 0.1$	Ignore																															
$0.1 < \Phi \leq 0.2$	2																															
$0.2 < \Phi \leq 0.3$	(distance $\geq$ 10mm)																															
$0.3 < \Phi$	0																															
	Assembly deflection	beyond the edge of backlight $\leq 0.15$ mm																														

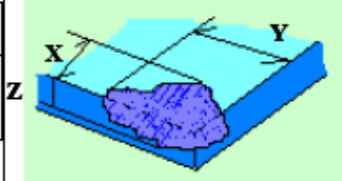
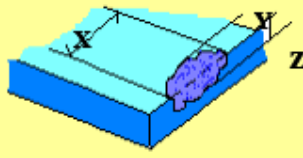

5.0	TP Related	Newton Ring	Newton Ring area > 1/3 TP area NG	 1 规律性  2 非规律性  似牛顿环					
			Newton Ring area ≤ 1/3 TP area OK						
	TP corner broken X: length Y: width Z: height	<table border="1"> <tr> <td>X</td> <td>Y</td> <td>Z</td> </tr> <tr> <td>X ≤ 3.0mm</td> <td>Y ≤ 3.0mm</td> <td>Z &lt; LCD thickness</td> </tr> </table> * Circuitry broken is not allowed.	X	Y	Z	X ≤ 3.0mm	Y ≤ 3.0mm	Z < LCD thickness	
X	Y	Z							
X ≤ 3.0mm	Y ≤ 3.0mm	Z < LCD thickness							
	TP edge broken X: length Y: width Z: height	<table border="1"> <tr> <td>X</td> <td>Y</td> <td>Z</td> </tr> <tr> <td>X ≤ 6.0mm</td> <td>Y ≤ 2.0mm</td> <td>Z &lt; LCD thickness</td> </tr> </table> * Circuitry broken is not allowed.	X	Y	Z	X ≤ 6.0mm	Y ≤ 2.0mm	Z < LCD thickness	
X	Y	Z							
X ≤ 6.0mm	Y ≤ 2.0mm	Z < LCD thickness							

**Criteria ( functional items)**

Number	Items	Criteria (mm)
1	No display	Not allowed
2	Missing segment	Not allowed
3	Short	Not allowed
4	Backlight no lighting	Not allowed
5	TP no function	Not allowed



## 10.2 RELIABILITY TEST

NO	ITEM	CONDITION	STANDARD
1	High Temp. Storage	70°C, 12 hours	1. Functional test is OK. Missing Segment, short, unclear segment, non- display, display
2	Low Temp. Storage	-20°C, 12 hours	

3	High Temp. Operation	60°C, 12 hours	
4	Low Temp. Operation	-10°C, 12 hours	
5	High temperature and high Humidity storage	40°C,90%RH ,12 hours	
6	Thermal and cold shock	Static state, -20°C (30 Min) ~70°C (30 Min) ~ -20°C (30Min) , packaging, 10 cycles	
7	Vibration test	Packaging, Frequency : 10-55Hz Amplitude : 1.0mm, Each direction on X,Y axe 0.5 heure, circle 2 hours	
8	Dropping test	Pack products into the carton box. Drop it from 80cm height to ground. Once for each side of the carton	1. Function test is OK. 2. No glass crack, chipped glass, end seal loose and fall, epoxy frame crack and so on. 3. No structure loose and fall.

### NOTE:

- 10.2.1 The reliability items will be fully performed in new sample qualification,
- 10.2.2 The reliability status will be tested as monitor during mass production. Individual reliability test shall be performed by lot , Moreover, the individual reliability item shall be decided according to reliability plan.
- 10.2.3 All samples are inspected after keeping in the room with normal temperature and humidity for 2 hours or above.
- 10.2.4 Vibration test: It is not necessary to test for those products without assembly frame , back light ,PCB and so on.
- 10.2.5 Dropping test : It is necessary for affirming new package.
- 10.2.6 For the high temperature and high humidity test, pure water of over 10 MΩ.cm should be used.
- 10.2.7 Each test item applies for test LCM only once .Then tested LCM cannot be used again in any other test item.
- 10.2.8 The quantity of LCM examination for each test item is 5pcs to 10pcs.

## 10.3 Safety instructions

- 10.3.1 If the LCD panel breaks, be careful not to get any liquid crystal substance in your mouth.
- 10.3.2 If the liquid crystal substance touches your skin or clothes, please wash it off immediately by using soap and water.

## 10.4 Handling precautions

- 10.4.1 Avoid static electricity damaging the LSI.
- 10.4.2 Do not remove the panel or frame from the module .
- 10.4.3 The polarizing plate of the display is very fragile . So, please handle it very carefully.
- 10.4.4 Do not wipe the polarizing plate with a dry cloth, as it may easily scratch the surface of the plate.
- 10.4.5 The color tone of display and background of LCM has the possibility to be changed in the storage temperature range.
- 10.4.6 Pay attention to the working environment, as the element may be destroyed by static electricity.
  - Be sure to ground human body and electric appliance during work.
  - Avoid working in a dry environment to minimize the generations of static electricity.
  - Static electricity may be generated when the protective film is fast peeled off.
- 10.4.7 When soldering the terminal of LCM, make certain the AC power source of soldering iron does not leak.
- 10.4.8 If the display surface becomes contaminated ,breathe on the surface and gently wipe it with a soft-dry- clean cloth .If it is heavily contaminated ,moisten cloth with the following solvent(ex:Ethyl alcohol).Solvents other than those above-mentioned may damage the polarizer(Especially ,do not use them .ex: Warter / Ketone)

## 10.5 Operation instructions

- 10.5.1 It is recommended to drive the LCD within the specified voltage limits, try to adjust the operating voltage for the optimal contrast, the color and contrast of LCD panel will varies at different temperature.
- 10.5.2 Response time is greatly delayed at low operating temperature range. However, this does not mean the LCD will be out of the order, It will recover when it returns to the specified temperature range.
- 10.5.3 If the display area is pushed hard during operation, the display will become abnormal.
- 10.5.4 Do not operate the LCD at the environments over the specified conditions, this may cause damage on the LCD and shorten the lifetime.

## 10.6 Storage Instructions:

- 10.6.1 Store LCDs in a sealed polyethylene bag.
- 10.6.2 Store LCDs in a dark place, Do not expose to sunlight or fluorescent light. Keep the temperature between 0°C and 35°C.
- 10.6.3 Avoid the polarizer touch any other object, ( It is recommended to store them in the container in which they were shipped.)

## 10.7 Limited Warranty

10.7.1 will replace or repair any of its LCD modules, which are found to be defective, when inspected in accordance with LCM acceptance standards ( copies available upon request ) for a period of 12 months from ink- print date on product

10.7.2 Any defects must be returned to within 60 days since ship-out. Confirmation of such date shall be based on freight documents. The warranty liability of wasam limited to repair and/or replacement on defects above (7.1,7.2)

10.7.3 No warranty can be granted if the precautions stated above have been disregarded. The typical samples are as below:

- LCD glass crack/break
- PCB outlet is damaged or modified.
- PCB conductors damaged.
- Circuit modified with by grinding, engraving or painting varnish.
- FPC crack

10.7.4 Modules must be returned with sufficient description of the failures of defects. Any connectors or cable installed by the customer must be removed completely without damaging the PCB outlet, conductors and terminals. Modules must be packed with the container in which they were shipped.

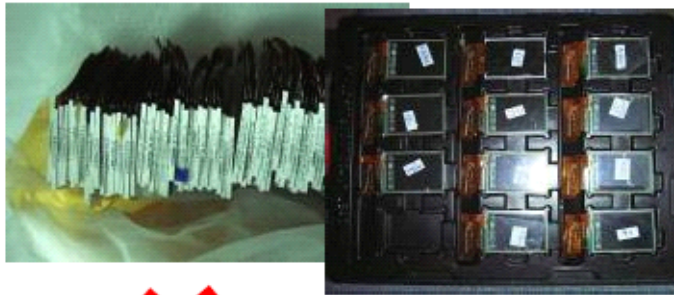

## 11.Packing method.

TBD

**12. REVISION HISTORY.**

Version	Revise record	Date
00	Original version	13-04-08
01	Change the interface from 37 to 40 pin	13-04-11
02	Change the LCM view direction	13-04-18
03	Change the LCM connect for connector	13-05-08
03.1	Perfect the VER03 spec, Commany internal modify.	13-08-01

JEWEL HILL



SAMPLE APPROVED REPORT (样品确认单)

SAMPLE MODEL NO. (样品型号)	JH24240320C
SAMPLE SERIES NUMBER NO. (样品序号)	
SAMPLE QUANTITY (样品数量)	-
COLOR/TYPE (底色/类型)	TFT/NEGATIVE
VIEWING DIRECTION (视角)	3:00
DRIVING METHOD (驱动参数)	262K,1/320DUTY,
LOGIC VOLTAGE (工作电压)	2.8V
LCD VOP (LCD 驱动电压)	-
OPERATING TEMP. (操作温度) °C	-10~60°C
STORAGE TEMP. (储存温度) °C	-20~70°C
POLARIZER----FRONT (首偏光片)	TRANSMISSIVE
POLARIZER----BACK (后偏光片)	
CONTROLLER/DRIVER IC(控制/驱动 IC)	ILI9341 (COG)
BACKLIGHT COLOR/TYPE (背光源类型/颜色)	LED/WHITE
BACKLIGHT VOLTAGE (背光电压)	-
SPECIFICATION (规格书 份数)	1BATE
REMARKS: (备注)	
WRIT BY: _____ DATE: _____ APROV BY: _____ DATE: _____	
CUSTOMER'S APPROVAL (客户确认):	
1) FUNCTION (功能): <input type="checkbox"/> OK <input type="checkbox"/> N.G.	
2) DRIVER CONDITION (驱动条件): <input type="checkbox"/> OK <input type="checkbox"/> N.G.	
3) DISPLAY MODE (显示模式): <input type="checkbox"/> OK <input type="checkbox"/> N.G.	
4) VIEWING ANGLE (视角): <input type="checkbox"/> OK <input type="checkbox"/> N.G.	
5) BACKLIGHT (背光源): <input type="checkbox"/> OK <input type="checkbox"/> N.G.	
6) DISPLAYING PATTERN (显示效果): <input type="checkbox"/> OK <input type="checkbox"/> N.G.	
CUSTOMER'S CONCLUSIONS (客户意见): _____	
_____	
_____	
CUSTOMER'S SIGNATURE (客户签名): _____ DATE (日期): _____	