

SCREW COVER
SET SCREW LOCK

SCREW COVER

52mm
(2.047") INSIDE Ø

27.4mm
(1.079")

1/2" NPT

GROUND SCREW
(INTERNAL)

GROUND SCREW
(EXTERNAL)

3/4" NPT

JMS PART #
6IAIEC

FM / CSA: Class I, Div I Groups B, C, D
Class II, III Div I Groups E, F, G
Type NEMA 4X IP66

ATEX: II2 g Exd II C Gb IP66
II2 D Ex tb III C D b IP66

IECEX: Ex d IIC Gb
Ex tb IIIC Db IP66

Ta = -40°C to 85°C

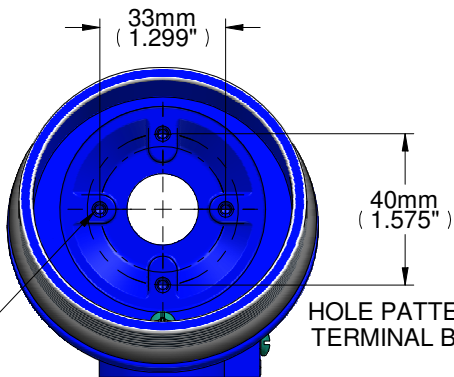

DESCRIPTION

1 HEAD, EXPLOSION PROOF, NEMA 4X IP 68, ALUMINUM, EPOXY BLUE, SCREW COVERED CAP CHAIN,, 3/4" X 1/2" FNPT, BUNA N O-RING

JMS SOUTHEAST INCORPORATED CERTIFIES THIS DRAWING IS IN ACCORDANCE WITH JMS SOUTHEAST INCORPORATED ENGINEERING SPECIFICATIONS AND ACCURATELY REPRESENTS THE EQUIPMENT FURNISHED. THIS DRAWING IS THE SOLE PROPERTY OF JMS SE, AND MUST BE RETURNED UPON DEMAND IT MAY NOT BE REPRODUCED NOR THE INFORMATION CONTAINED THEREIN USED WITHOUT THE WRITTEN PERMISSION OF JMS SOUTHEAST INCORPORATED

Company Name:		JMS-SE HEADS	
Reference Data:	Drawing #:		

TOLERANCE TABLE:	Approvals	Initials	Date
PROBE (L): 0-48" ±1/8" 48"-144" ±1/4" 144" + -1"/+2"	Drafting		
WIRE (L): -24" -1/2"/+1" >24" -1/2"/+2"			
PROT. TUBE (P&U): ±1/4" FRACTIONAL DIM: ±1/8" DECIMAL DIM: ±0.10" XXX ±0.010" XXXX ±0.005" UNLESS STATED OTHERWISE	Engineering		
	Second		



JMS SOUTHEAST, INC.
Temperature Measurement
105 Temperature Lane
Statesville, North Carolina 28677
Phone: (704) 873-1835
Fax: (704) 878-6166
www.jms-se.com
Email: sensors@jms-se.com