

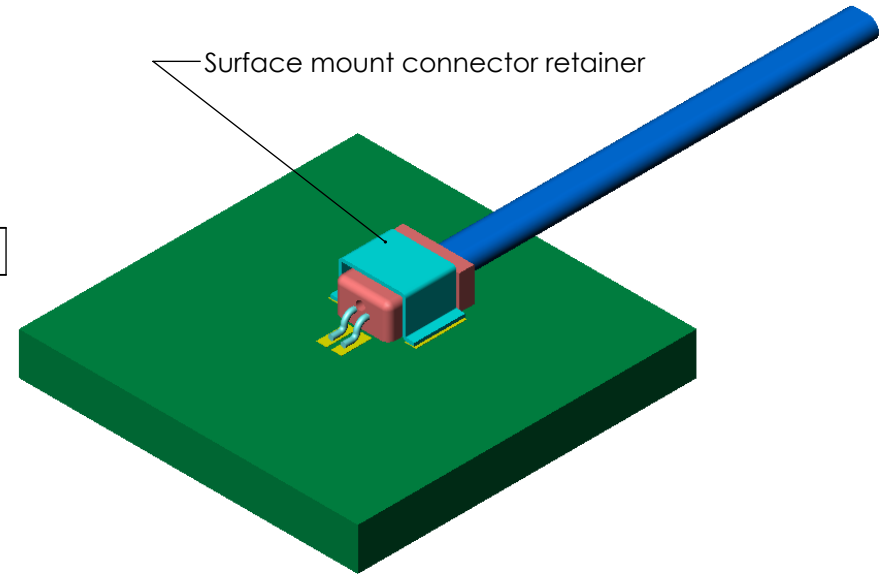

8 7 6 5 4 3 2 1

THE INFORMATION CONTAINED IN THIS DRAWING IS THE SOLE PROPERTY OF JOY SIGNAL TECHNOLOGY ANY REPRODUCTION IN PART OR WHOLE WITHOUT THE WRITTEN PERMISSION OF JOY SIGNAL TECHNOLOGY IS PROHIBITED.

REV	DESCRIPTION	DATE	INITIAL
X2	Added stop bumps	3/14/02	JWJ
X3	Turned over body and made thicker	3/14/02	JWJ

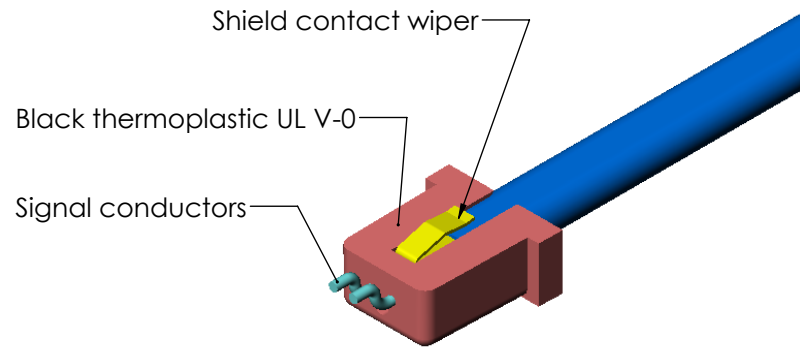
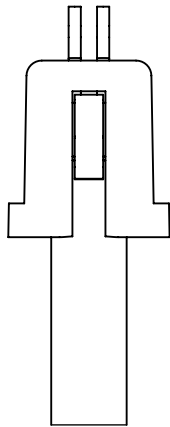
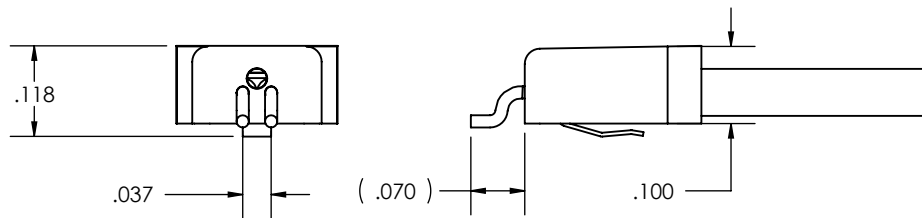
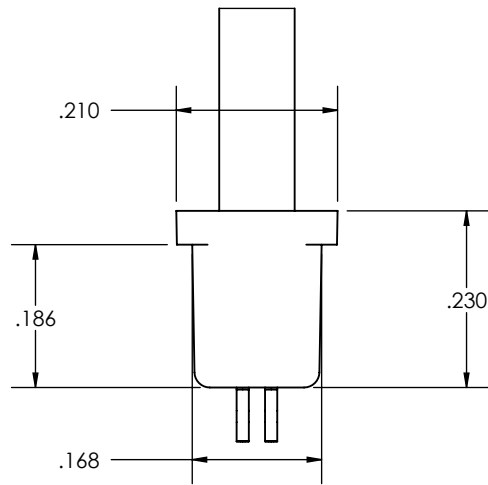

ITEM NO.	PART OR IDENTIFYING NO.	NOMENCLATURE OR DESCRIPTION	MATERIAL SPECIFICATION	QTY REQD
PARTS LIST				
UNLESS OTHERWISE SPECIFIED DIMENSIONS ARE IN INCHES TOLERANCES ARE:		CAD GENERATED DRAWING, DO NOT MANUALLY UPDATE		 Differential Connector Surface Mount using cable conductors
FRACTIONS DECIMALS ANGLES		APPROVALS DATE		
.XX : ±.01		DRAWN JWJ 2-19-02		
.XXX : ±.005		CHECKED		
MATERIAL --		RESP ENG CAS 2-19-02		SIZE A DWG. NO. J-000041-X3 REV.
FINISH --		MFG ENG		
NEXT ASSY USED ON		QUAL ENG		
APPLICATION		DO NOT SCALE DRAWING		SCALE CAD FILE: SHEET 1 OF 1

8 7 6 5 4 3 2 1

THE INFORMATION CONTAINED IN THIS DRAWING IS THE SOLE PROPERTY OF JOY SIGNAL TECHNOLOGY ANY REPRODUCTION IN PART OR WHOLE WITHOUT THE WRITTEN PERMISSION OF JOY SIGNAL TECHNOLOGY IS PROHIBITED.

REV	DESCRIPTION	DATE	INITIAL

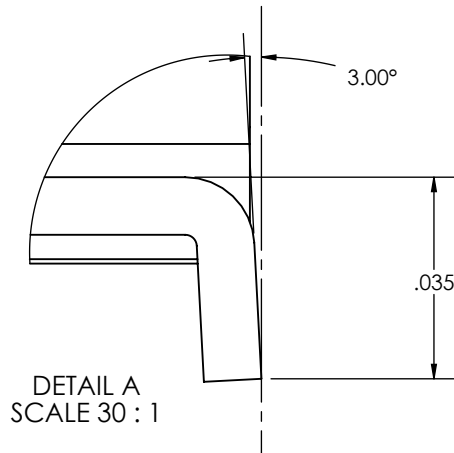
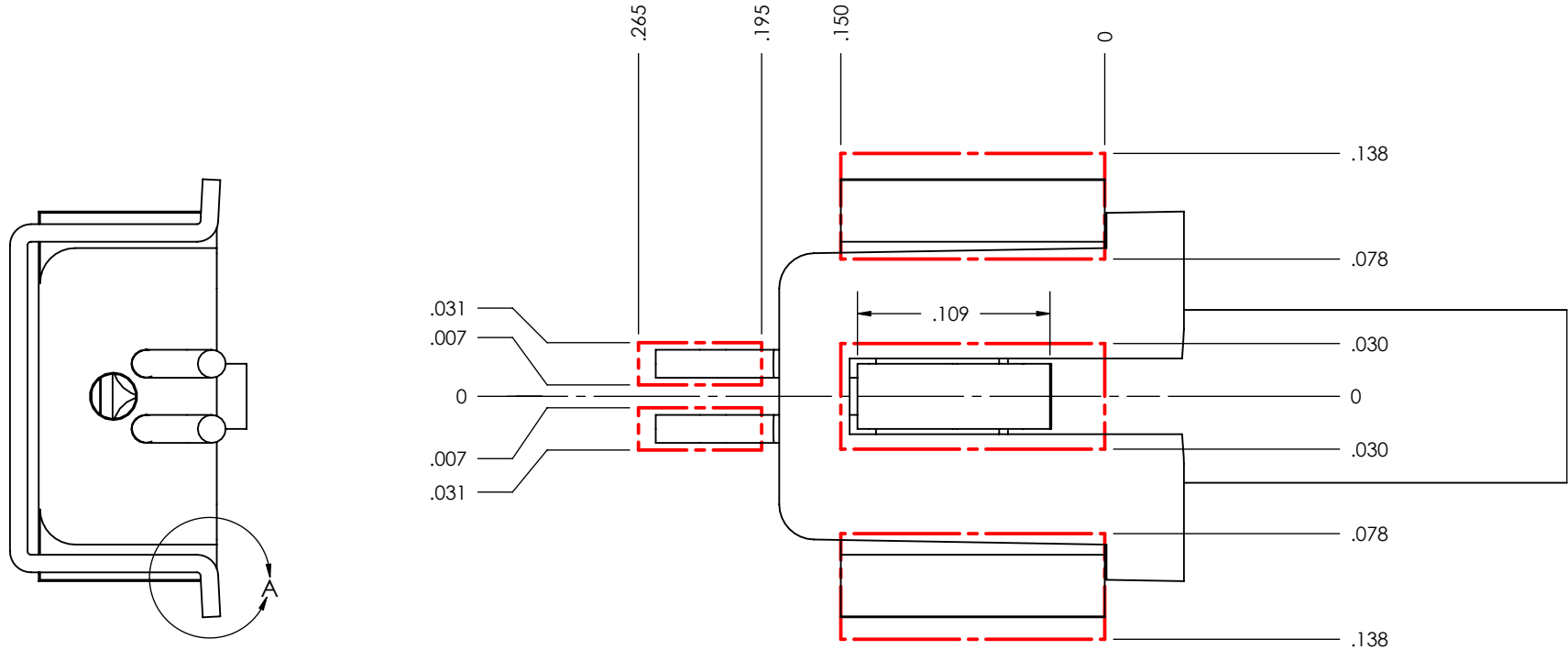

This pad layout is for reference only. Each application requires individual optimization.

ITEM NO.	PART OR IDENTIFYING NO.	NOMENCLATURE OR DESCRIPTION	MATERIAL SPECIFICATION	QTY REQD
PARTS LIST				
UNLESS OTHERWISE SPECIFIED DIMENSIONS ARE IN INCHES TOLERANCES ARE:		CAD GENERATED DRAWING, DO NOT MANUALLY UPDATE		
FRACTIONS DECIMALS ANGLES		APPROVALS DATE		
.XX : ±.01		DRAWN JWJ 4-02-02		
.XXX : ±.005		CHECKED		
MATERIAL --		RESP ENG CAS 4-02-02		
FINISH --		MFG ENG		
NEXT ASSY	USED ON	QUAL ENG		
APPLICATION		DO NOT SCALE DRAWING		
		 Solder Pad Constraints for Surface Mount Differential Connector		
SIZE A	DWG. NO.	J-000041-X3		REV.
SCALE	CAD FILE:	SHEET		OF

8 7 6 5 4 3 2 1

THE INFORMATION CONTAINED IN THIS DRAWING IS THE SOLE PROPERTY OF JOY SIGNAL TECHNOLOGY ANY REPRODUCTION IN PART OR WHOLE WITHOUT THE WRITTEN PERMISSION OF JOY SIGNAL TECHNOLOGY IS PROHIBITED.

REV	DESCRIPTION	DATE	INITIAL
B	Increased height and width by .002", added iso view, deleted sheet 2	1/9/03	JWJ
C	Chg to production stamped version	2-6-03	JWJ
D	Removed .120 hght dim, added angle tol	2-6-03	JWJ
E	Added tolerance to .110 dim, added .150 width dim.	3-23-03	JWJ

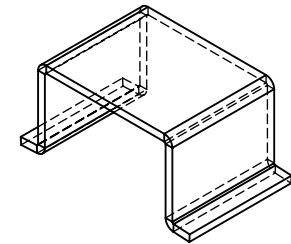
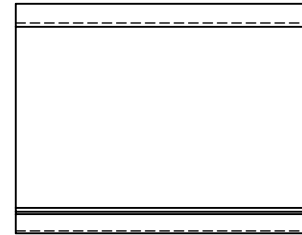
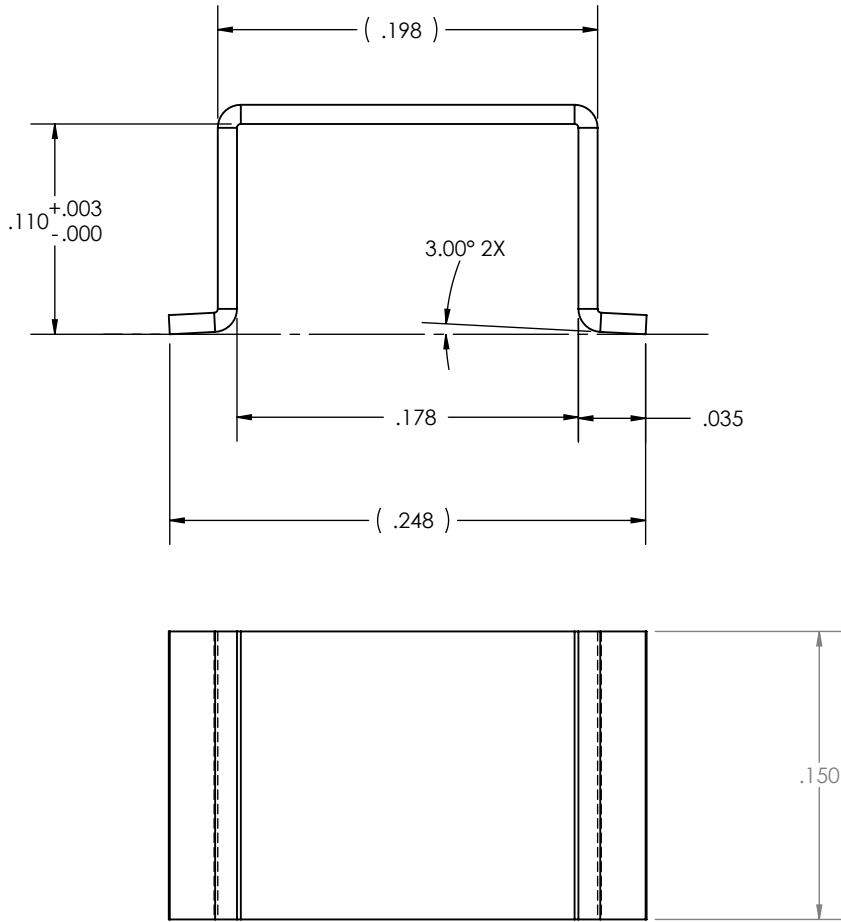

Notes:

- 1. Material thickness: .010 ±.0005

ITEM NO.	PART OR IDENTIFYING NO.	NOMENCLATURE OR DESCRIPTION	MATERIAL SPECIFICATION	QTY REQD
PARTS LIST				
UNLESS OTHERWISE SPECIFIED DIMENSIONS ARE IN INCHES TOLERANCES ARE:		CAD GENERATED DRAWING, DO NOT MANUALLY UPDATE		 Retainer, Diffconn, SM Stamped version
FRACTIONS DECIMALS ANGLES		APPROVALS	DATE	
.XX : ±.01 .0: ±1		DRAWN	JWJ 4-02-02	
.XXX : ±.003 .00: ±.5		CHECKED		
MATERIAL		RESP ENG	CAS 4-02-02	
FINISH		MFG ENG		
NEXT ASSY	USED ON	QUAL ENG		
APPLICATION		DO NOT SCALE DRAWING		
SIZE A	DWG. NO. 690418		REV. E	
SCALE	CAD FILE:		SHEET 1 OF 1	