

Handling Precaution for Terminal and Connector

Handling Precaution for Terminal and Connector

This manual is to describe basic precautions for use of terminal and connector in the following. Make use of this manual when wire connection processing is conducted in appliance designing and harness process.

When there are doubtful points in use, contact JST.

1. Common Handling Precautions

- JST's terminal and connector are designed to connect electricity and electrical signal, and not aimed to be used as structure or a part of structure premising that mechanical force loads to connection part (contact part) of JST's terminal and connector.
- JST's terminal and connector are designed for wiring in electrical appliances or between electrical appliances.
JST's terminal and connector are designed only for usage of "domestic wiring of electrical appliance" in Electrical Appliance and Material Safety Law.
Appropriate provision is required for electrical appliances so that general person does not touch terminal and connector.
- JST's terminal and connector are designed to aim electrical connection in electrical appliances or between electrical appliances.
They are not "connection appliance" conformed to Electric Appliance and Material Safety Law, so that they cannot use for wiring inside building material and cable wiring for indoor and outdoor.
- JST cannot guarantee the performance of our product when used outside the published design specifications.
- Use JST's terminal and connector within the range of rated value of product specification and performance specification.
This rated value and performance specification are specified as parts themselves, when using in actual use, use them after checking to satisfy regulation and design standard about appliances to be used.
- JST cannot accept responsibility for the performance of our product when used in combination with non-JST terminals and connectors.
- Do not expose JST's terminal and connector, processing process product and processing product (harness, etc.) to corrosive substance, corrosive gas, high temperature and high humidity and direct sunshine. It causes corrosion of contact and deterioration of insulation performance of housing, etc., so that it causes motion defect of appliances.
- Do not apply external load to JST's terminal and connector, processing process product and processing product (harness, etc.). Deformation and breakage, etc. occur, and it causes performance defect of connector.
- Although it is confirmed the foreign substance such as black spot in the resin molding part of the connector and the color tone might be different, it does not affect the performances of the connector.

Handling Precaution for Terminal and Connector

- When checking circuit of harness with terminal and connector, handling wire harness, etc. in assembly of appliances or after wiring is fixed or applying load, due to tensile strength, to joint part of JST's terminal and connector, joint part of contact contacting part and wire is damaged and causes of contact defect. When handling and wiring wire harness, etc., provision such as an appropriate slack to wire is required in order not to apply abnormal load to joint part of JST's terminal and connector. See examples 1 and 2.

Example 1: Wire to Board connectors

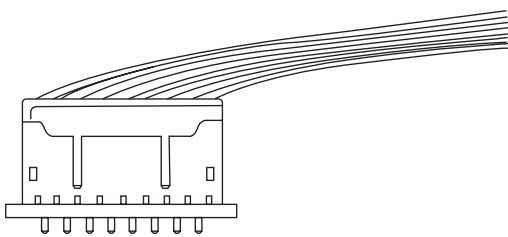

× Wire length is not sufficient to handle.

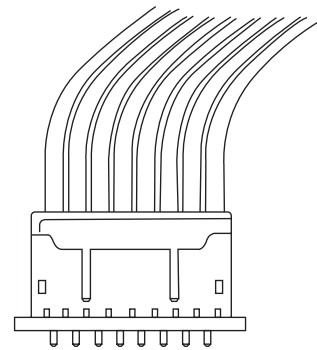

○ Wire length is sufficient to handle.

Example 2: FFC/FPC connectors

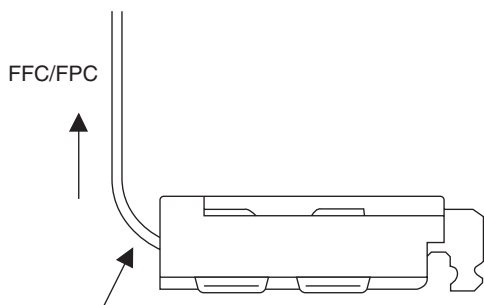

Force is loaded to FFC/FPC.

× FFC/FPC length is not sufficient to handle.

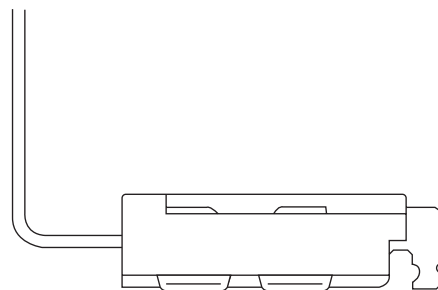

○ FFC/FPC length is sufficient to handle.

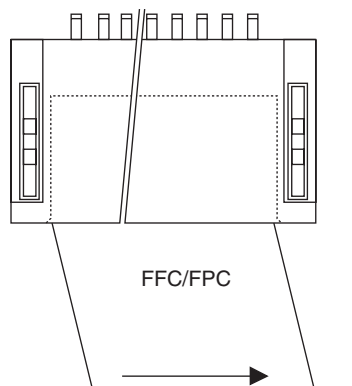

Force is loaded to FFC/FPC.

× Force is loaded to FPC.

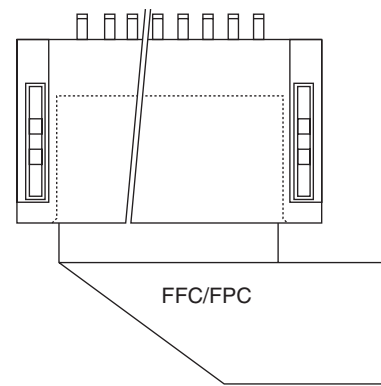

○ Forming processing is conducted to FPC so as not to load force to connector.

Handling Precaution for Terminal and Connector

•When disconnectable JST's terminal and connector is mated and unmated (hereafter referred to as disconnection operation) in check of harness, etc., assembly of appliances and maintenance such as repair, etc., hold wire in a bundle and operate it within 15 degrees which is an indicated angle (see example 3 & 4). As for operation angle specified in JST product specification or JST handling manual, the specified one is prior.

Disconnection operation beyond specified angle leads to expanding of mating part of contact, and causes of contact defect.

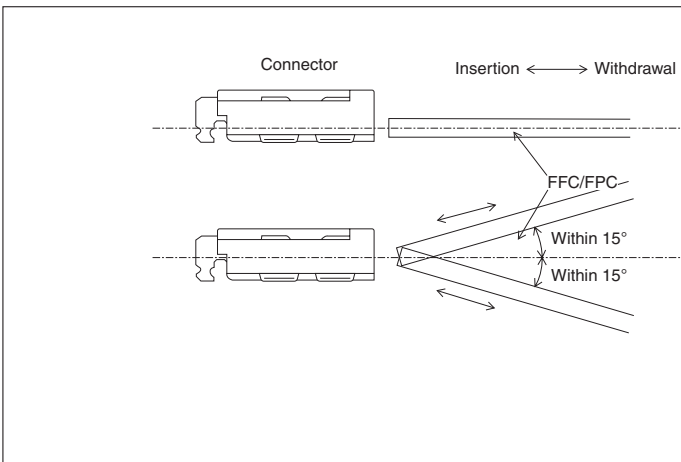
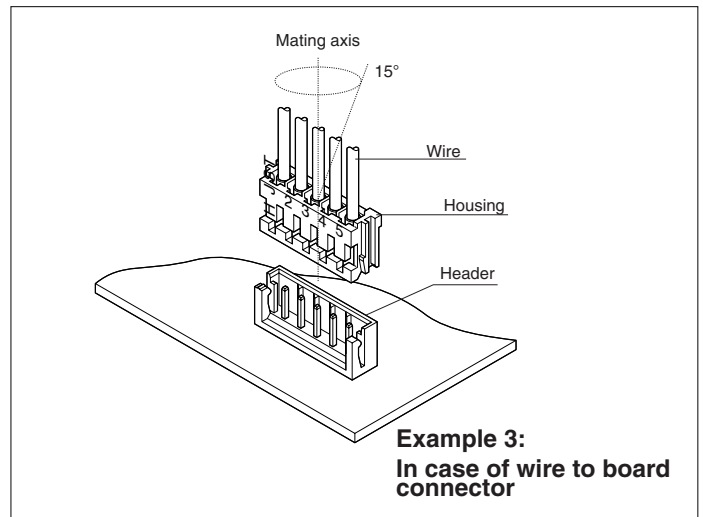

•When electrical continuity of circuit and miss-wiring are checked, do not insert others than the applicable mating (shrouded header and header, etc.). It leads to deformation of contact, etc., and causes of contact defect.

•In packaging and storage of processing product of JST's terminal and connector, do not apply load by stack, etc. for a long time.

It leads to deformation of JST's terminal and connector, and causes of performance defect.

Precaution of Reflow Soldering for SMT type product

●Reflow soldering for SMT type product

As for SMT type product, tenacious heat-resistant resin is used for the material of a wafer. However, please conduct the reflow soldering evaluation because the reflow soldering quality of SMT type product is greatly affected by soldering conditions such as the temperature profile, solder paste to be used, air reflow and nitrogen (N₂) reflow.

●Considering handling of SMT type connector in mating operation, tenacious heat-resistant nylon is used for the material of a wafer. But 'blister' may generate on the outer surface of the wafer during the process of reflow soldering, depending on the condition of moisture absorption of the wafer and the condition of reflow soldering. However, because 'blister' is not caused by decomposition of resin, it does not affect the performances of the connector.

Handling Precaution for Terminal and Connector

2. Handling Precaution for Terminal and Connector in Electrical Appliances —————

- JST's terminal and connector are not designed so that they may disconnect in live electrical circuit. Do not disconnect JST's terminal and connector in the live electrical condition in order to prevent damage and performance defect by spark, etc.
- In case that condensation and water leak occurred on JST's terminal and connector, there is a risk that insulation defect may occur between circuits. When it is estimated that condensation and water leak occur, appropriate countermeasure to prevent waterdrop is required.
- When using JST's terminal and connector, avoid using to branch and apply electricity more than rated value to some circuits. Even if electricity per a circuit is set not to exceed rated value on calculation, electricity per a circuit is not shared equally due to variation of circuit pattern and contact resistance, so that performance deterioration makes progress by current continuity more than rated value, and abnormality occurs.
- When connectors are used at parts that wire and printed circuit board with connectors resonate or mating part (connection part) of connector always moves whenever appliance has rotation structure or moving part, that causes contact defect by fretting corrosion of contact part.
Appropriate provision such as fixing of wire and printed circuit board in appliances or support of printed circuit board and suppression of resonance, etc.
- When contact material of JST's terminal and connector is brass, breakdown and cracking (stress corrosion cracking) occur in the existence of corrosive gas and moisture (condensation, etc.) of ammonia and sulfur gas, etc., and that causes of contact defect of connector. When effect of corrosive gas of ammonia and sulfur gas, etc. aforementioned condition is expected in use place of terminal, connector and its electrical appliances to use, use copper-alloy material (phosphor bronze material, etc.) except for brass material as a contact material. Contact JST for products.
- After connector was connected to printed circuit board with solder, when printed circuit board is stacked on connector, deformation of mating part of connector and adhesion of foreign matter occur, and that causes of contact defect of connector. Do not stack printed circuit board after connection with solder.

3. Note for Wire Connection Processing of Harness Processing, etc. —————

- When JST's terminal, chain terminal and connector are crimped or terminated with wire, use tools specified in JST. If connection is conducted by other tools than the specified one, it causes of contact defect and breakage. Besides, after checking processing operation condition, etc., process harness.
- As defect control of important control point on wire connection processing of JST's terminal and connector such as applicable wires and crimp height, etc. causes contact defect, check control point before processing.
- As a rule, applicable wires for crimping connector and insulation displacement connector are tin-plated annealed copper wire (stranded wire). It is necessary to check when using bare copper wire, solid wire, tin-coated wire and shielding wire. However, wires of terminal and connector specified individually are decided depending on each specification.
When wire is used in insulation displacement connector, use wire checked in JST.

Precaution for Crimping Process

The following instructions describe the procedure to be adopted when crimping terminals or contacts onto wires. Please read the relevant connector and application tooling “Handling Manuals” prior to terminating the connector. If you need any further information, please contact JST.

1. Crimping tools

When JST chain terminals are crimped or terminated with wires, always use application tooling specified by JST. If this process is conducted using application tooling other than that specified, product defect and failure may occur. JST cannot accept any liability for failures due to the use of non-JST application tooling.

2. Applicable wires

Before starting the crimping process, please confirm that the wire to be used is within the range of the chosen crimping terminal.

As a rule, applicable wires for crimping connector are tin-plated annealed copper stranded wire. Bare copper wire, solid wire, tin-coated wire, shielded wire and so on are out of range. However, it is possible to use other wires if they are checked for compatibility with the chosen crimping terminal.

3. Control Points for Crimping Operation

Please check the following points to ensure that a correctly crimped terminal and wire combination is produced.

3.1 Checking Application Tooling

Read the “Operation/Handling Manuals” which are available for each press and application tool prior to commencing the crimping operation.

3.2 Stripping Wire Insulation Operation

As the wire stripping length is influenced by wire style, crimping method and so on, please set the proper stripping length according to processing condition. After setting the correct length depending on the terminal used, strip the insulation carefully by a wire stripper etc. without any damage to the wire conductors.

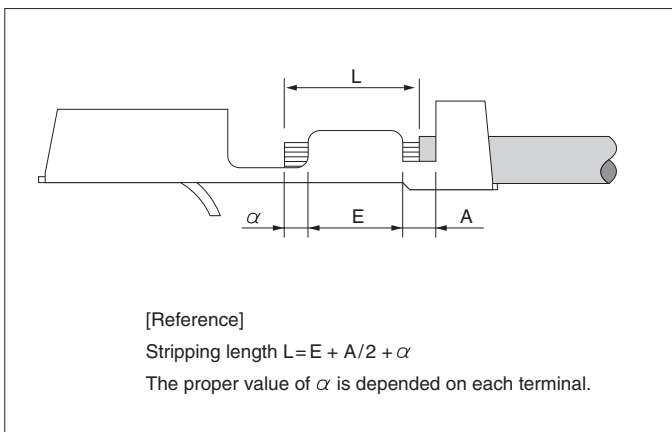

[Cautions]

- (1) Take care to prevent cutting of wire conductors, uneven stripping length and insufficient cutting of the insulation.
- (2) Ensure the strands do not spray come apart.
- (3) Do not excessively twist the strands.

Precaution for Crimping Process

3.3 Crimping Height

Crimping height is one of the important quality management items on crimping process. As crimping terminals without the correct crimp-height is the cause of poor conductivity, measure the crimp-height at the start, in the middle and at the end of the crimping process.

1) Measuring Method

Measure the crimping height of the crimped terminals with a specified crimp micrometer (designed by JST) at the center of the wire barrel and at the center of the insulation barrel.

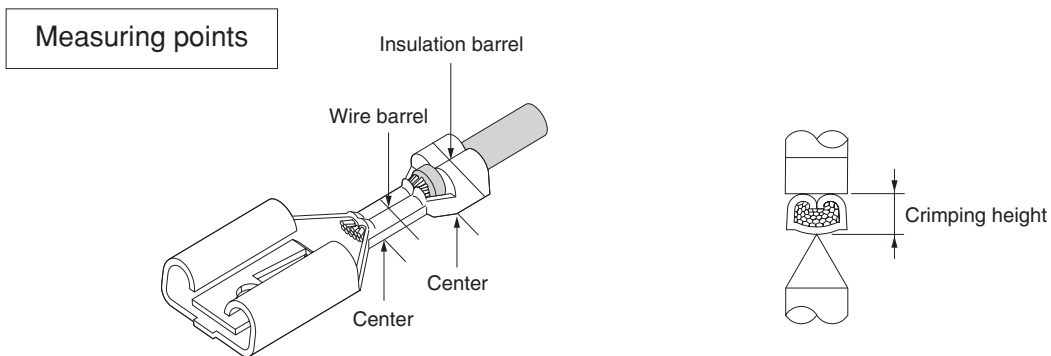

2) Crimping height for wire barrel

Set the crimping height of the wire conductor barrel within the range specified by JST.

3) Crimping height for insulation barrel

Adjust the crimping height of the insulation barrel in relation to the outer diameter of the wire insulation and wire type. Determine the range of crimping height for insulation barrel so that it is not crimped excessive nor too loosely.

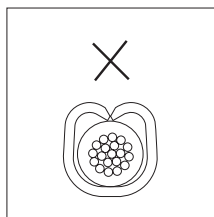

- Insufficient crimping
- Wire insulation is easily pulled from the terminal when applying tension to the wire.

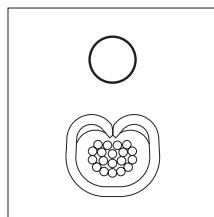

- Good

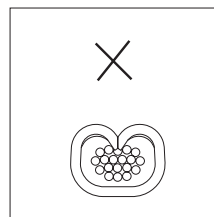

- Excessive crimping
- The barrel edges cut into the wire & damage the conductors.

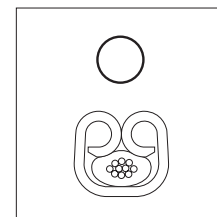

- Good

Check: Cut off the insulation support and remove the wire insulation, then check the wire conductors for damage.

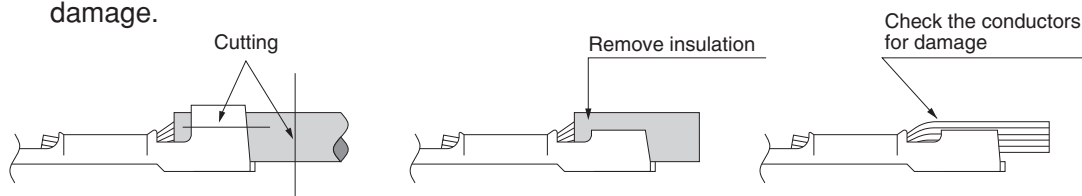

Precaution for Crimping Process

3.4 Crimped Appearance

Check crimped appearance visually (using loupe etc.) in order to confirm correct crimping condition. As the inspection items change with each terminal, an example is shown below.

Check the Handling Manual for each terminal or connector about the specific details to be checked.

Bend up & Bend down

Check the angle of bend up or bend down at the wire barrel.

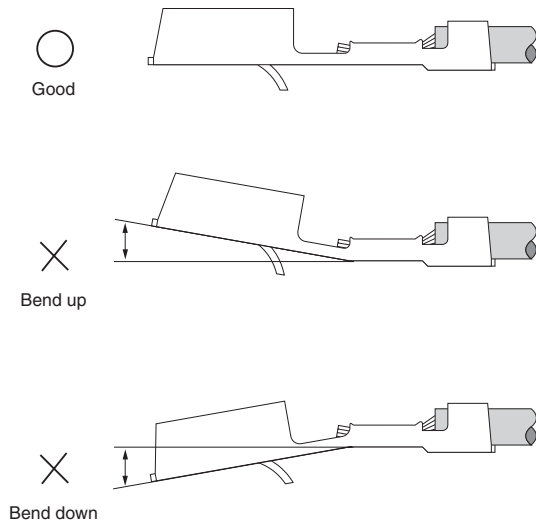

Twist

Check the angle of twist at the wire barrel.

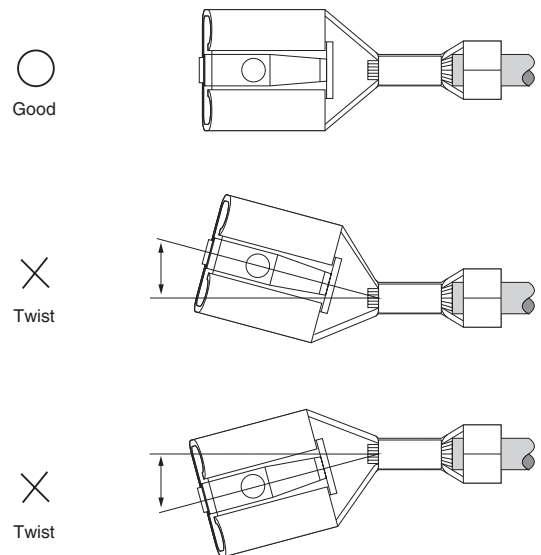

Rolling

Check the angle of rolling at the wire barrel.

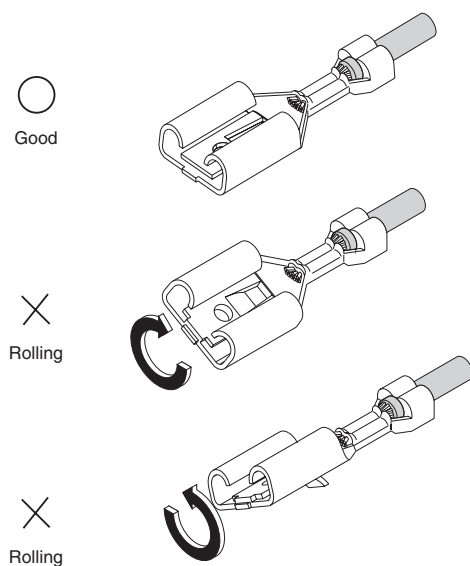

Uncrimped Conductor

Check that there are no uncrimped conductors at the wire barrel.

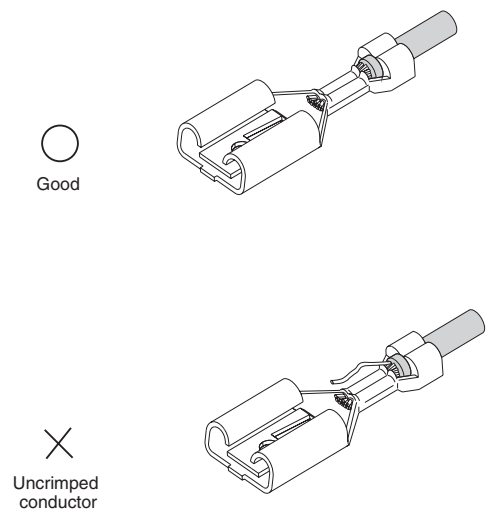

Precaution for Crimping Process

Bell-mouth

Check bell-mouth size.

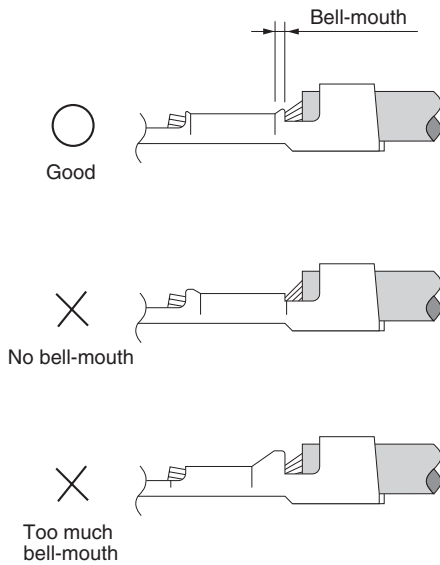

Cut-off Length

Check cut-off length.

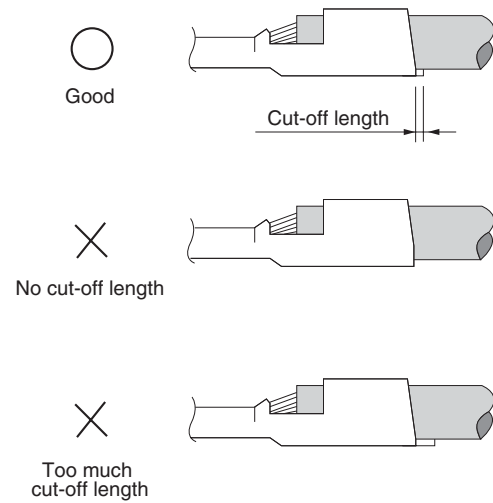

Wire Conductor Protruding Length

Check the conductors are crimped at the correct position of whole wire barrel.

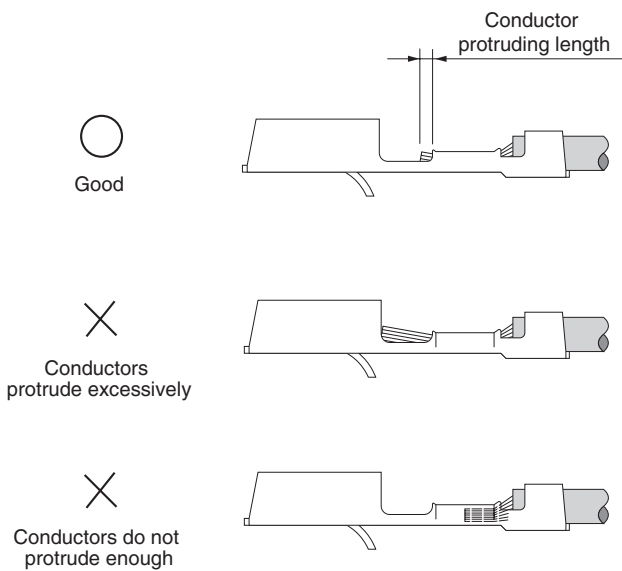

Wire Insulation Protruding Position

Check the wire insulation is held by the whole insulation barrel and crimped at the wire barrel, so that a "window" of conductor is seen between the wire and insulation barrel approximately 50/50.

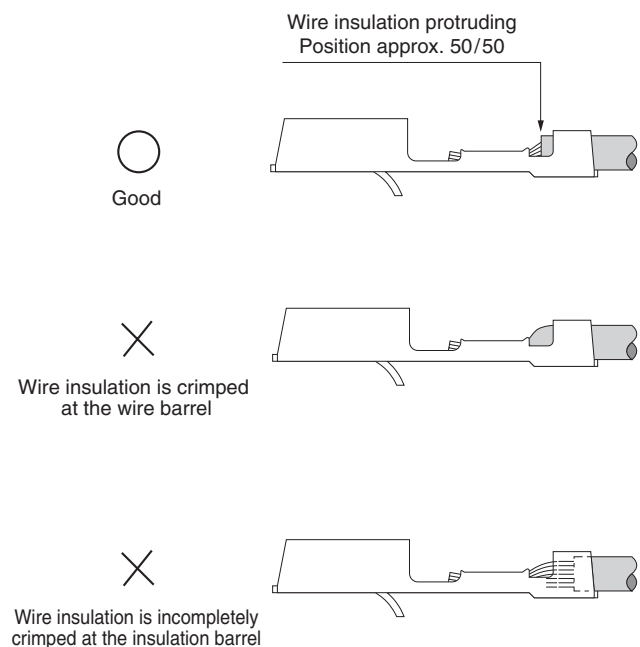

Precaution for Insulation Displacement

The following instructions describe the procedure to be adopted when terminating Insulation Displacement connectors. Please read the relevant I.D.Connector and application tooling “Handling Manuals” prior to terminating the connector. If you need any further information, please contact JST.

1. Insulation Displacement tools

When JST insulation displacement connector (ID connector) are terminated with wires, always use application tooling specified by JST. If this process is conducted using application tooling other than that specified, product defect and failure may occur. JST cannot accept any liability for failures due to the use of incorrect tooling.

2. Applicable wires

Wire to be used for ID connector, please use the wire that is specified by JST

As applicable wire for ID connector differs in the characteristics of wire insulation by the manufactures, wire evaluation test shall be carried out by JST, and propriety of wire applicability shall be determined. Please contact JST about suitability of the wire to be used.

3. Composition and Parts Identification of IDC

Composition and parts identification of ID connector are shown in the below figure.

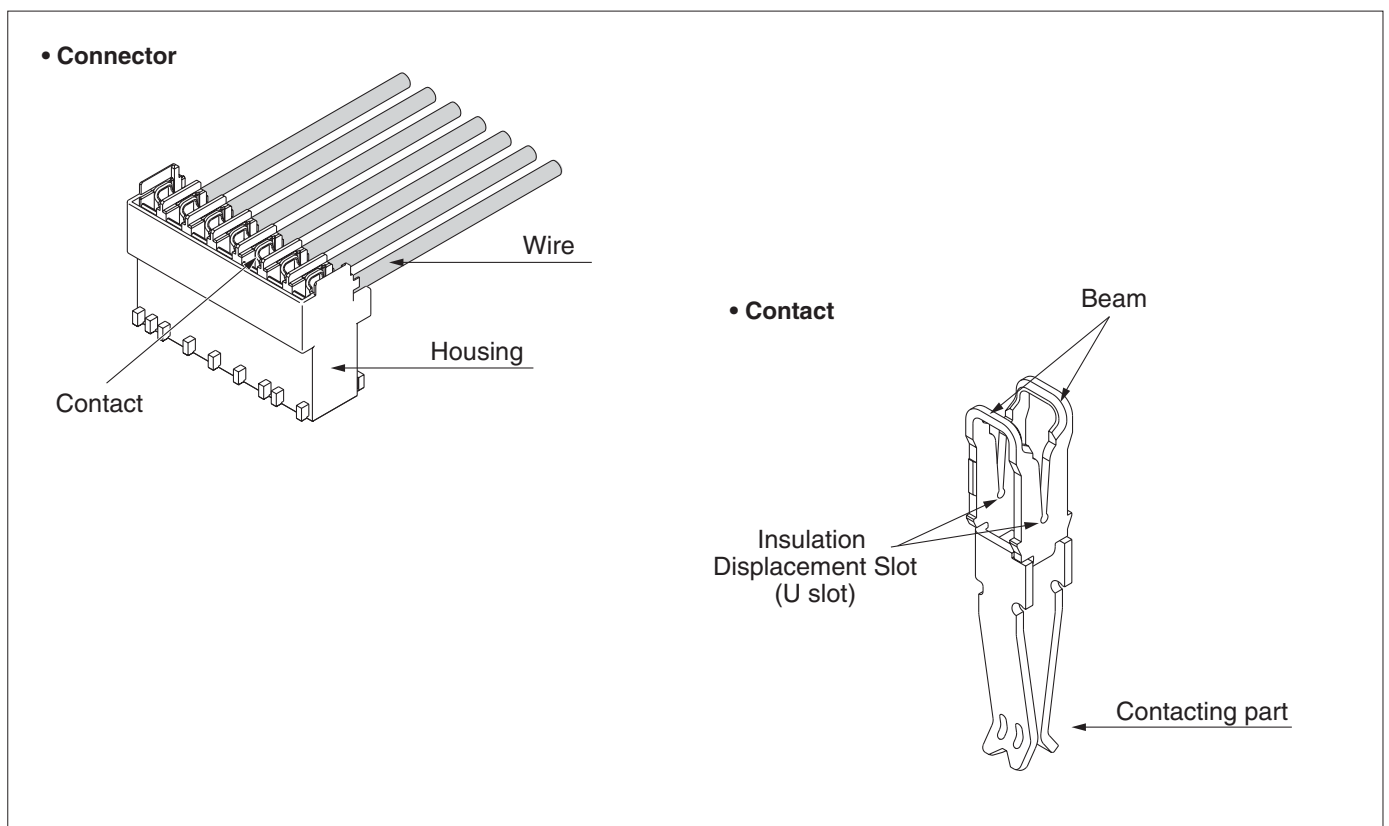

Precaution for Insulation Displacement Process

4. Control Points for Insulation Displacement Operation

In order to perform a good insulation displacement connection, please study the following points.

4.1 Insulation Displacement Machine

Handling Manuals are available for each type of JST application tool. Please study the Handling Manual prior to using the tooling.

<Main Check Points>

① Hand Press

- ◎ Correct shut-height
- ◎ Set connector at the correct position
- ◎ No particles of wire insulation on the termination punch

② Pneumatic Press

- ◎ Air pressure should be within specified range.
- ◎ Set connector at the correct position
- ◎ No particles of wire insulation on the termination punch

③ Automatic ID Machine

- ◎ Each part should move freely.
- ◎ Connector should be correctly fed at bowl-feeder and straight chute
- ◎ Adequate tension should be applied to wire
- ◎ Measuring wire length should be correctly set up to specified wire length
- ◎ Connector should be set at the correct position
- ◎ If a connector with a different number of circuits is to be used, check that any previously used connectors are removed from track and bowl-feeders.
- ◎ No particles of wire insulation on the termination punch or wire guide.

4.2 Connector & Wire Size

Each ID connector has been designed for specified the wire size, please ensure that the correct connector is selected for use with the applicable wire conductor size from Handling Manual etc.

4.3 Termination Depth

A specific termination depth has been developed for each particular wire and connector combination. Please ensure that the applicable Handling Manual is checked for the particular wire size that is chosen to be used.

4.3.1 What is Termination Depth

The termination depth is used as a running check during production of the ID harness. This dispenses of the requirement to check the termination depth using destructive methods. Each connector has a u-slot designed for a specific conductor wire size, therefore providing the wire used is within specification of the connector, it is only necessary to manage the depth of the wire in the u-slot during production. The true termination depth is “d” in the figure of next page, i.e. check the position of center of wire conductor from bottom of U slot. However, as the result of checking the condition of the insulation displacement at U-slot and measuring wire retention force, we specify termination depth “D” as the checking point during production.

Precaution for Insulation Displacement Process

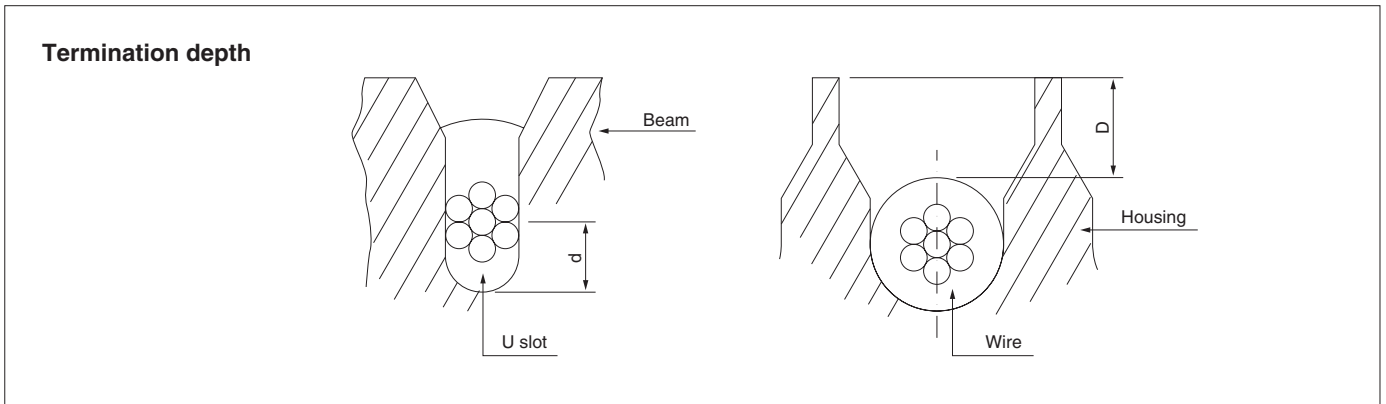

4.3.2 How to Measure Termination Depth

The termination depth shall be measured in the figure below at X-X' part, where is in the middle part of two U slots and a flattened part pressed by termination punch, immediately after termination operation. If the termination depth is not measured immediately after the termination operation, the insulation will try and revert to its original shape and correct termination depth can not be measured.

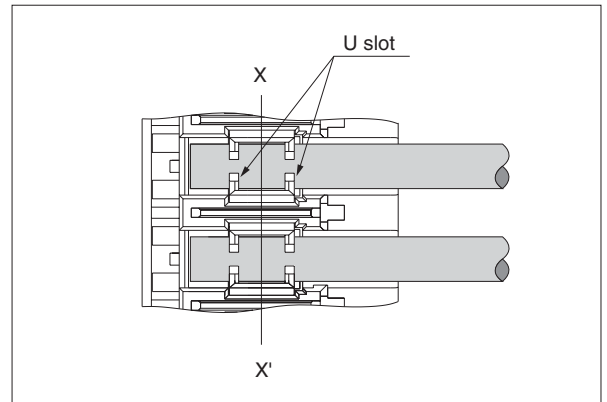

4.4 Wire Retention Force

Wire retention force is specified for each combination between ID connector and wire.

The wire retention force is specified in the applicable connector Handling Manual.

The terminated wire shall be pulled one by one in the direction of arrow in the figure below, and wire retention force shall be measured by a push-pull gauge etc. When the wire pulls out of the contact, it should be checked that wire retention force is in compliance with the requirement for each ID connector.

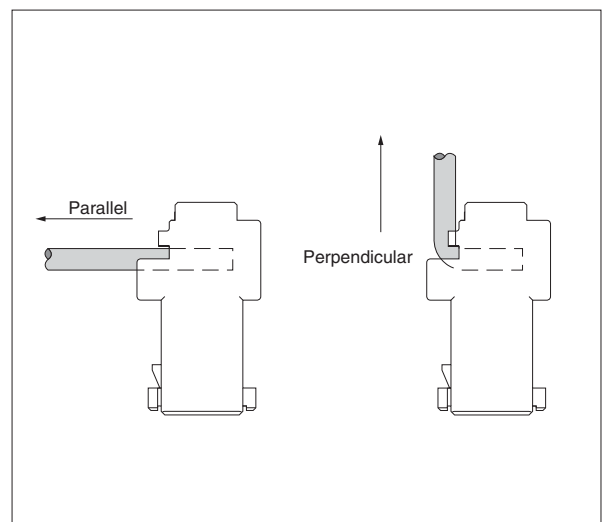

Precaution for Insulation Displacement Process

4.5 Termination Appearance

Check termination appearance visually (using loupe etc.) in order to confirm correct termination.

As the inspection items change with each ID connector, an example is shown below.

Check the Handling Manual for each ID connector about the specific details to be checked.

Defects or deformation on housing

Check for defects or deformation on housing

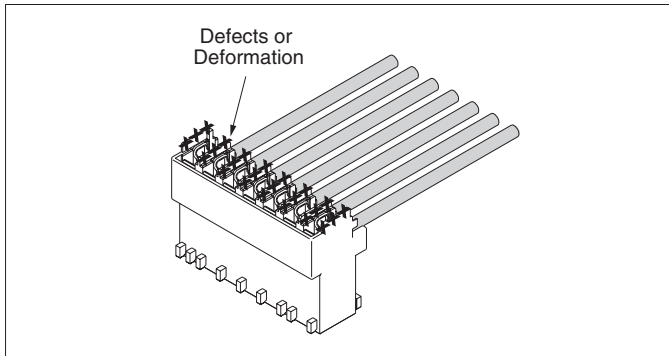

Defects or deformation on Contact

Check for defects or deformation on contact

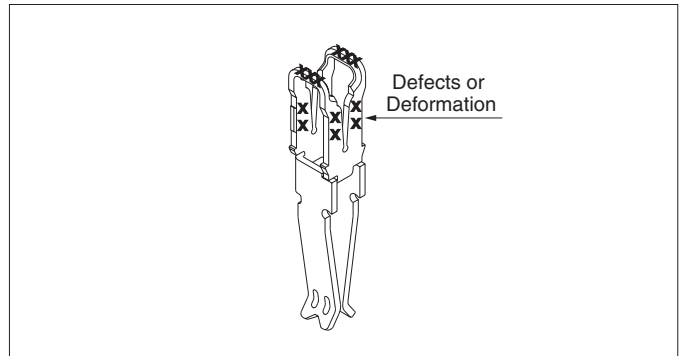

Exposure of wire conductors around beam of contact

Check that the wire conductors are not exposed around the beam of contact.

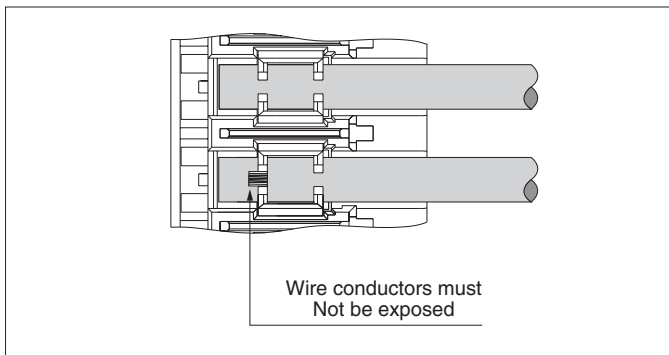

Gap between housing wall and wire tip (Wire protruding length)

Check gap "G" between housing wall and wire tip

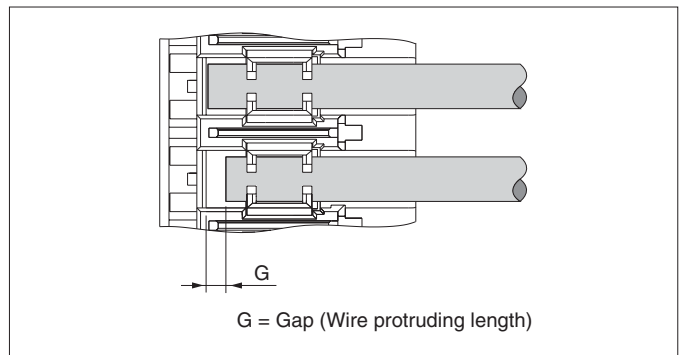

Overrun of wire

Check for overrun of wire

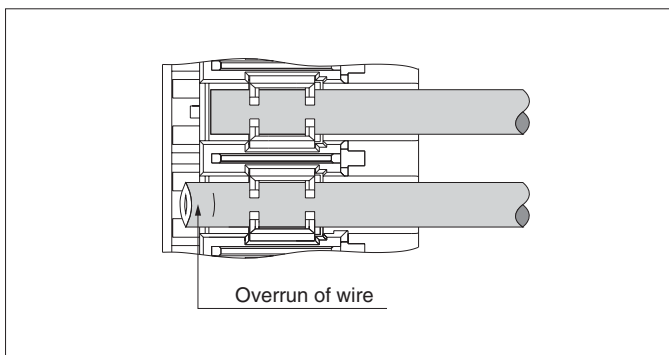

Deviation of ID center

Check for no deviation of insulation displacement center

