

PRESSURE CALIBRATORS

LP / MP / HP

LOW PRESSURE (LP) / MEDIUM PRESSURE (MP) / HIGH PRESSURE (HP)

These Pressure Calibrators from KELLER are very precise calibration instruments for the calibration of pressure transmitters, pressure switches and pressure gauges.

The Low- and Medium ranges are pneumatic, and the High ranges are hydraulic. The portable housing incorporates the pressure generating pump, a high precision reference sensor and the measuring electronics.

The transmitter under test is connected to the pressure port of the calibrator and the signal is read out directly on the display. Various internal functions and performance features assist the user in many different measuring tasks. In addition, the serial interface allows the transfer of the measured data onto a PC for further processing. The calibrator, including accessories, is supplied with a robust carrying case and is ideal for outdoor, on-site use.

To meet differing requirements, two basic versions of the calibrator are offered

Full-Version

The Full-Version of the calibrator is a complete, self-contained transmitter testing unit. With internal supplies for the transmitter and the calibrator itself, the self-contained instrument is always ready for use. For a variety of measuring and testing tasks, a wide selection of software functions are incorporated:

Mano	displays the pressure and the maximum and minimum pressures
Mano*	displays the pressure, the transmitter signal and the temperature
Hold	freezes the actual measured values on the display
Tara	sets the pressure display to zero (volatile)
Unit	scales the display into different pressure units (bar, PSI, kPa...)
Leak	determines the pressure decrease (or increase) over a pre-set time period
Rec	records the measured values (the number of values and the interval are programmable)
Reso	reduces or increases the resolution
Zero	sets the pressure display to zero (permanently)
Pst	records the switching points of pressure switches
Lin	calculates the linearity error of the test transmitter

* with transmitter connected

Standard-Version

The Standard-Version is limited to the essential features for precision pressure generation only. For this simplified operation, this version does not include the integral transmitter supply, nor the display of the transmitter signal. Thus it does not incorporate the Pst and Lin functions.



High Pressure Calibrator Outline Drawing

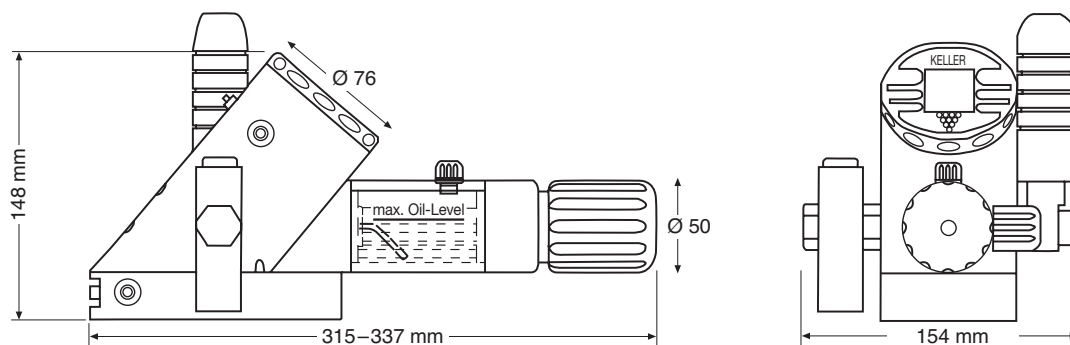

Subject to alterations

05/06

KELLER AG für Druckmesstechnik
KELLER Ges. für Druckmesstechnik mbH

St. Gallerstrasse 119
Schwarzwaldstrasse 17

CH-8404 Winterthur
D-79798 Jestetten

Tel. +41 (0)52 - 235 25 25
Tel. +49 (0)7745 - 9214 - 0

Fax +41 (0)52 - 235 25 00
Fax +49 (0)7745 - 9214 - 60



KELLER

Specifications

Pressure Ranges (FS)	bar	-1...2	-1...10	-1...25	0...200	0...350	0...700
Overpressure	bar	2,4	12	30	240	420	840
Low Pressure Calibrator (LP)		[Bar chart showing range from -1 to 10]					
Medium Pressure Calibrator (MP)			[Bar chart showing range from -1 to 25]				
High Pressure Calibrator (HP)				[Bar chart showing range from 0 to 700]			
Total Accuracy ⁽¹⁾		0,1 %FS max.					
Measuring Interval		0,5 sec. (1 second with transmitter or pressure switch connected)					

⁽¹⁾ Includes linearity, repeatability, hysteresis, temperature and resolution of the display over the range 0..50 °C

Electrical Characteristics

Electronic Supply	Lithium-battery 3,6 V (included)
Battery Life	> 200 days at continuous operation
Transmitter Supply (Full-Version only)	max. 18 VDC (2 x 9 V batteries) or with 230 VAC adapter (included)

Environmental Characteristics

Operating Temperature	0...50 °C
Compensated Range	0...50 °C
Storage Temperature	-20...60 °C
Display	0...50 °C
Air Humidity	5...95 % relative humidity

Mechanical Characteristics

Calibrator-Housing	Polyamid 12
Weight	1,6 to 4,0 kg, depending on model
Pressure Connection	Serto + different adapters
Protection	IP 54
Hydraulic Oil ⁽²⁾	Type HLP 22 BP

⁽²⁾ High range only

Options

- Logger-Software for data transfer to PC and cable K101 (see below)
- Extended memory up to 8000 storage places for the Rec-function (standard 900 storage places)

Logger

The Logger-Software allows the read-out of the stored data from the calibrator. The data transfer takes place via the serial interface on the PC.

The calibrator is connected through a cable K101 (supplied with Logger software).

The Logger-Software offers many further processing possibilities of the read-out data, and meets all the requirements of modern Windows software:

- Graphical Display
- Tabulated Display
- Export into other Windows Programs
- Storage into Files

