

## HIGH-PRECISION PRESSURE LEVEL TRANSMITTER

## SERIES 36 Xi W (CTD)

### MULTI-PARAMETER PROBE WITH DIGITAL INTERFACES

The 36 Xi W series is built on the latest-generation microcontroller platform, which KELLER has developed to meet extremely high precision requirements and increase compatibility with a wide variety of interfaces. Along with pressure (level) information, digital interfaces also transmit other water parameters such as temperature and conductivity.

**RS485** Robust interface with differential gauges, for lines up to 1,4 km in length. Modbus RTU and proprietary KELLER bus protocol

**SDI-12** Standard interface for environmental monitoring, ideal for battery operation

The 36 Xi W series is based on the proven KELLER 36 X W series using the high-quality 10 L-series pressure transducer. All series X pressure level transmitters feature an RS485 interface, which provide pressure and temperature standard, while versions requiring higher accuracy, temperature or conductivity sensor are available options. Multi-parameter probes fitted with pressure, temperature and conductivity sensors (CTD – conductivity, temperature, depth), are approximately 90 mm longer.

**36 Xi W** Pressure sensor: accuracy 0,02 %FS  
Temperature sensor: accuracy 0,5 °C or 0,1 °C

**36 Xi W CTD** Pressure sensor: accuracy 0,02 %FS  
Temperature sensor: accuracy 0,1 °C  
Conductivity sensor: accuracy 2,5% of the selected measuring range 4 ranges: 0,2 / 2 / 20 / 200 mS/cm

Both versions can be supplied configured for absolute pressure (measured relative to a vacuum → PAA) or relative pressure (fitted with capillary tubes for measuring relative to atmospheric pressure → PR).

#### Characteristics

- Pressure sensor: resolution 5 ppm
- Mathematical compensation of nonlinearities and temperature dependencies
- Sturdy stainless steel housing (titanium or Hastelloy also available)
- Extended lightning protection fitted to the SDI-12 interface as standard
- Level measuring ranges from 0...3 to 0...300 mH<sub>2</sub>O. Higher ranges are possible using a SubConn® connector
- Ultra-high long-term stability



Series 36 Xi W

Modbus RTU  
SDI-12

Series 36 Xi W CTD

#### Electrical connections

Function	Wires
+Vcc	Black
GND	White
RS485A	Blue
RS485B	Yellow
optional	
SDI-12	Red
CASE	Cable shield





## Interfaces

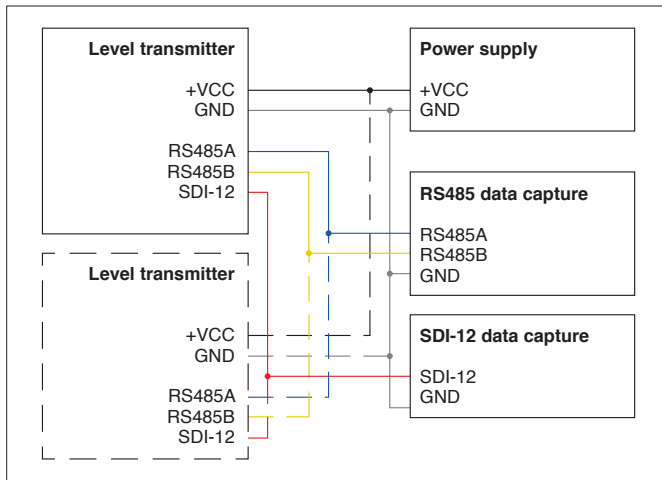

### RS485

#### Modbus RTU / KELLER bus protocol

The extremely robust RS485 interface enables a bus system to be created with up to 128 users and a total line length of up to 1,4 km. The baud rate of the half-duplex interface can be switched between 9600 and 115'200. The proprietary KELLER bus protocol and the Modbus RTU protocol are already implemented, allowing the measured values to be read off and configuration and calibration to be performed. The free CCS30 software for PC can be used for this.

Measuring channel assignment (up to 4 channels):

P1	Pressure
TOB1	Temperature (silicon sensor)
T	Temperature (Pt1000)
Con	Conductivity

A detailed description of RS485 communication can be found on the KELLER website.

### SDI-12

As well as the standard RS485 interface, which provides access to all configuration registers, the pressure level transmitter can also be ordered with an SDI-12 interface. Only one interface will be active at any one time. Corresponding commands are used to switch between interfaces (default setting on delivery: SDI-12).

SDI-12 is a tried-and-tested standard for connecting data loggers and digital sensors in environmental monitoring applications. The SDI-12 interface has been optimised for use in battery-operated systems that employ a data logger and multiple sensors on the same bus. The interface is underpinned by a standardised, ASCII-based bus protocol. In SDI-12 mode, the pressure level transmitter is only active when it is being actuated by the data logger or logging a measurement. At all other times, the transmitter is in standby mode, requiring very little current (< 0,1 mA).

Standard commands:

- Reading off measurements with and without checksum
- Changing the sensor address
- Reading off ID

Advanced commands:

- Adjusting the pressure and temperature unit
- Adjustable zero point and amplification
- Adjustable gravitational constant to increase measuring accuracy
- Programming a user-specific ID
- Configurable continuous measurement with adjustable measuring interval and communication of up to eight pressure waves
- Switching to RS485

A detailed description of SDI-12 communication can be found on the KELLER website.

### Sensor system

#### Pressure measurements

The pressure level transmitters are calibrated with pressure in bar. The measuring and testing equipment used has been calibrated to national standards.

The RS485 interface always displays pressure in bar. In SDI-12 mode, it is possible to select the unit in which the pressure value is transmitted. The pressure can be read off as a level (water depth) based on the following formula:

$$h = f \cdot \frac{p}{\rho \cdot g}$$

- p Pressure (measured value)
- $\rho$  Water density at 3,98 °C (constant of 1000 kg/m<sup>3</sup>)
- g Gravitational acceleration (can be configured; default: 9,80665 m/s<sup>2</sup>)
- f Factor used in conversion to unit of height (underlying table)

Depending on the design of the pressure level transmitter, pressure can be recorded relative to a vacuum (PAA models) or to ambient pressure (PR models).

#### Temperature measurements

Two different temperature sensors are available with varying degrees of calibration and accuracy. End-of-line calibration is performed on Pt1000 sensors in a water bath. The temperature information (TOB) from the silicon sensor is always available and is also used for temperature compensation in the pressure sensor, with which it forms a single unit. The Pt1000 sensor in the conductivity module is positioned between the electrodes to provide as accurate a medium temperature as possible, which is then used for temperature compensation of the conductivity.

#### Conductivity measurements

Conductivity measurements are used in the monitoring of bodies of water (environment). Thanks to four-wire technology, the conductivity probe is not influenced by polarisation effects or dirt. Methods for temperature compensation of the conductivity output\*:

- Normalization to 25 °C or to 20 °C through linear compensation in the range of 0 to 8%/K according to DIN/EN27888.
- or normalization to 25 °C through non-linear table

The Conductivity is calibrated via the RS485 interface using the software "ConductivityCalibration Tool".

The conductivity probe is only switched on in SDI-12 mode when a conductivity measurement is requested. In RS485 mode, the conductivity probe can be switched on and off to save energy.

\* Default configuration is linear compensation with 2,2%/K normalized to 25°C. Other customised factory setting possible upon demand. Customer can enter new alternative settings any time via software.



## Specifications

Pressure	
Standard ranges in bar <sup>1)</sup>	
PR (relative pressure)	0,3    1    3    10    30 <sup>2)</sup>
PAA (absolute pressure)	0,8...2,3    0,8...4    0,8...11    0,8...31 <sup>2)</sup>
Water column in metres ca.	3    10    30    100    300
Overload resistance	max. 300%
Technology	oil-filled, insulated, piezoresistive pressure transducer in a metallic casing
Resolution	typ. 5 ppm (corresponds to 0,0005 %FS)
Accuracy <sup>3) 5)</sup>	± 0,02 %FS max. (0,3 bar Range: ± 0,04 %FS)
Comp. temp. range	0...50 °C
Total error band <sup>4) 5)</sup>	± 0,1 %FS max. (0,3 bar Range: ± 0,2 %FS)
Operating temperature <sup>5)</sup>	-20...80 °C
Int. measuring rate (adjustable)	120, 240 (default), 480 Hz
Long-term stability	ranges > 1 bar: ± 0,1 %FS max. ranges ≤ 1 bar: ± 1 mbar max.
Degree of dependency on location	± 1,5 mbar max.

Temperature	
Measuring range	-10...80 °C
Technology	silicon (pressure measuring bridge, TOB <sup>6)</sup> ) optional Pt1000
Resolution	< 0,01 °C
Accuracy	silicon sensor: typ. ± 0,3 °C Pt1000 sensor: ± 0,1 °C max.
Int. measurement rate	12 Hz TOB only <sup>6)</sup> 6 Hz Pt1000 without conductivity 1 Hz Pt1000 with conductivity

Conductivity	
Measuring range	0 µS/cm...200 mS/cm
Ranges selectable using software	0,2 / 2* / 20 / 200* mS/cm
Technology	6 platinum electrodes, 4-wire technology
Comp. temp. range	-10...+60 °C
Resolution	< 0,05% of the selected range
Accuracy	< 2,5% of the selected range
Int. measurement rate	1 Hz

Options	
<ul style="list-style-type: none"> <li>• Housing options: Hastelloy and titanium</li> <li>• Process connection with thread</li> <li>• Other cable materials (e.g. FEP) available on request</li> </ul>	

Electrical data	RS485	SDI-12
Supply voltage	3,2...32 VDC	6...32 VDC
· with extended lightning protection	4,5...32 VDC	
Power consumption		< 0,1 mA (sleep)
· without conductivity	< 6 mA (active) <sup>7)</sup>	< 5,5 mA (active)
· with conductivity	< 14 mA (active) <sup>7)</sup>	< 13 mA (active)
Start-up time P1, TOB1 P1, T, Con	< 300 ms 3 s typ., 6 s max.	< 1 s < 3 s
Insulation GND-CASE	> 10 MΩ @ 300 V	
Endurance	> 10 mio. pressure cycles 0...100 %FS @ 25 °C	
Storage temperature	-20...+80 °C	

Digital interface	RS485	SDI-12
Communication protocol	Modbus RTU KELLER bus	SDI-12 V1.3
Baud rate	9600*, 115'200 bit/s	1200 bit/s
Identification	Class. Group: 5.21	
Units of pressure	bar	bar*, mbar, mH <sub>2</sub> O, psi, ftWC, inWC
Units of temperature	°C	°C*, °F, K
Unit of conductivity	mS/cm	mS/cm

Mechanical data	
Dimensions	ø 22 mm, length see drawing
Weight	ca. 170 g excl. cable (CTD ca. 300 g)
Housing material	stainless steel 316L (DIN 1.4435 / 1.4404)
Cable material	PR: polyethylen (PE) PAA: polyolefin (PE based)
Other materials in contact with media	seals: Viton <sup>®</sup> , protective cap: POM conductivity (additional): platinum, PEEK

Standards and protection	
EMC compliance	EN 61000-6-2: 2005 EN 61000-6-3: 2007 EN 61326-2-3: 2006
Reverse polarity and overvoltage protection	± 32 VDC power supply and RS485 ± 24 VDC SDI-12
Standard lightning protection in accordance with EN 61000-4-5	Line-Line: 50 A @ 8/20 µs Line-CASE: 200 A @ 8/20 µs
Extended lightning prot. (standard at SDI-12)	Line-Line: 10 kA @ 8/20 µs Line-CASE: 2 kA @ 8/20 µs
Degree of protection	IP68

<sup>1)</sup> Pressure range buffer: pressures can be measured at up to 10% outside the pressure range either way, in which case "+Inf" or "-Inf", as appropriate, will be displayed.

<sup>2)</sup> Subconn<sup>®</sup> connectors increase the pressure range to above 30 bar  
Pressure ranges > 10 bar are only possible without a conductivity sensor.

<sup>3)</sup> Linearity (best straight line), hysteresis and repeatability.

<sup>4)</sup> Accuracy and temperature error within the compensated temperature range.

<sup>5)</sup> Outside the compensated temperature range up to the limits of the operating temperature range, the deviation will be up to twice the value displayed.

<sup>6)</sup> Temperature information for the pressure sensor (TOB: top of bridge)

<sup>7)</sup> Power consumption without communication. During the response time (9 ms @ 9600 Baud, 1 ms @ 115'200 Baud), an extra 1...40 mA depending on the line termination.

\* Default setting, other defaults on demand. Customer can enter new alternative settings any time via software.