

MEDIUM-PRESSURE CALIBRATOR

MEDIUM: AIR / UP TO 25 BAR

KELLER pressure calibrators are highly accurate calibration instruments which are available for the following pressure ranges: -0,85...10 bar (LPX), -0,85...25 bar (MPX) or 0...700 bar (HPX) (special measurement ranges are available on request).

The medium-pressure calibrator (MPX) is used to generate pressure in order to check and calibrate mechanical and electronic pressure measurement devices with the help of comparative measurements.

The pressure generator is accommodated together with the pressure display in a functional housing. The pressure on a test object that is fitted to the calibrator can be built up quickly, and tracking is made easy thanks to the integrated display.

Test objects are connected to the medium-pressure calibrator via the Serto coupler and a connection nipple (G 1/4"). A hand pump (medium: air), integrated in the device, is used to build the pressure up to an approximate level with pulling and pumping movements; the pressure is then adjusted exactly with the help of the integrated fine-tuning valve.

Measurement work is made easier by a wide range of functions, such as setting any desired pressure zero point, display of peak and trough pressure values, or leak measurements.

Furthermore, the applied pressure can be displayed directly on a computer via the integrated interface (USB converter), after which it can be saved and processed or managed in any desired manner.

The calibrator, including accessories, is supplied in a durable carrying case, making it ideal for assignments in the field.

- Measurement accuracy: < 0,05% of the full pressure range
- Measurement interval: 0,5 seconds
- Pressure generation by means of air
- Battery-powered (normal commercially available button-cell battery)
- Battery lifetime: > 2000 h in continuous operation
- USB interface converter: included in the scope of delivery
- Ambient characteristics: 0...50 °C / 5...95% relative air humidity
- CE compliant / RoHS compliant

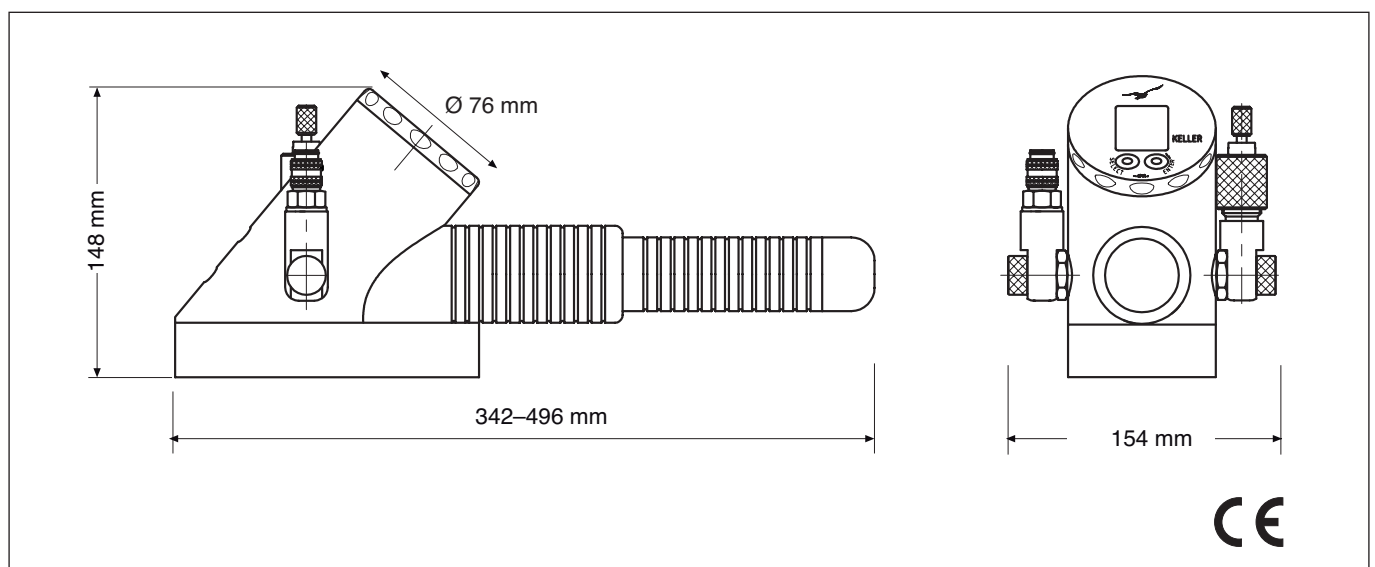

Subject to changes

10/2012

KELLER AG für Druckmesstechnik
KELLER Ges. für Druckmesstechnik mbH

St. Gallerstrasse 119
Schwarzwaldstrasse 17

CH-8404 Winterthur
D-79798 Jestetten

Tel. +41 (0)52 - 235 25 25
Tel. +49 (0)7745 - 9214 - 0

Fax +41 (0)52 - 235 25 00
Fax +49 (0)7745 - 9214 - 60



KELLER

Specifications

Pressure range (FS)	-0,85...25 bar (others on request)
Resolution	1 mbar
Overpressure	31 bar
Accuracy, error band ⁽¹⁾ (10...40 °C)	< 0,05 %FS
Accuracy, error band ⁽¹⁾ (0...50 °C)	< 0,1 %FS
Precision: optional (≥ 20 bar)	0,025% FS / 0,01% FS
Measurement interval	0,5 seconds

⁽¹⁾ including accuracy, temperature coefficients, zero point and range tolerance

Electrical characteristics

Power supply	3 V battery, type CR2430
Battery lifetime	> 2000 h in continuous operation

Ambient characteristics

Operating temperature	0...50 °C
Compensated range	0...50 °C
Storage temperature	-10...60 °C
Humidity	5...95% relative air humidity

Mechanical characteristics

Calibrator housing	Polyamide 12
Weight	approx. 2 kg
Pressure port	Serto and various adapters
Degree of protection	IP 65

Scope of delivery for medium-pressure calibrator (MPX)

- Calibrator
- Carrying case
- Spare battery, type CR2430 (3,0 V)
- Y-coupler
- Hose nipple
- Connection nipple, G 1/4"
- Sealing rings (G 1/8" + G 1/4")
- CrNi filter
- Vacuum pump
- USB interface converter, K-114A
- KELLER software CD
- Test record (5 points)
- Operating instructions



Subject to changes

10/2012

KELLER AG für Druckmesstechnik
KELLER Ges. für Druckmesstechnik mbH

St. Gallerstrasse 119
Schwarzwaldstrasse 17

CH-8404 Winterthur
D-79798 Jestetten

Tel. +41 (0)52 - 235 25 25
Tel. +49 (0)7745 - 9214 - 0

Fax +41 (0)52 - 235 25 00
Fax +49 (0)7745 - 9214 - 60