

PIEZORESISTIVE MINIATURE PRESSURE TRANSMITTER ABSOLUTE PRESSURE

SERIES 21 PY "PISELLO"

Ultramodern welding techniques and advances in the miniaturization of electronic circuits now make it possible to manufacture a pre-insulated, piezoresistive micro-transmitter with properties that were no more than a dream 10 years ago.

The circuit is based on the PromComp principle which KELLER offered in a separate version as a laboratory device 20 years ago when it attained accuracy of 0,1 %FS over a temperature range of 100 Kelvin (K). In those days the electronic circuitry was the size of a cigar box, but now it can be accommodated on a print that is a mere 12 mm in diameter. Although this digital component is only slightly more expensive to produce than a pure analog circuit, it allows a piezoresistive sensor to be calibrated to an accuracy of 0,5 %FS over a potential temperature range of 100 K.

A temperature sensor divides the temperature range into fields with a width of 1,5 K each. Two values are assigned to each field in an EEPROM: one value for the zero point and another for the amplification, determined by mathematical interpolation in the calibration process. During operation, the corresponding values are 'switched in' at the relevant temperatures. The electronics make it possible to assign up to 120 fields so that a temperature range of 180 K can be covered. The 100 K restriction for series 21 PY is due to the sensor.

This means that more or less any temperature can be the 'calibration temperature' for these transmitters. Calibration and temperature errors within a temperature field are within $\pm 0,2$ %FS. The remainder of the error bandwidth of $\pm 0,5$ %FS can be attributed to linearity and stability errors. So it's goodbye to the days when sensor engineers had to struggle every day with TKN (zero point) and TKG (gain/amplification) problems.

The 21 PY product line is outstanding due to its extreme ruggedness towards electromagnetic fields. The limits of the CE standard are undercut by a factor of up to 10 with conducted and radiated fields, thus making this product ideal for use in harsh industrial environments.

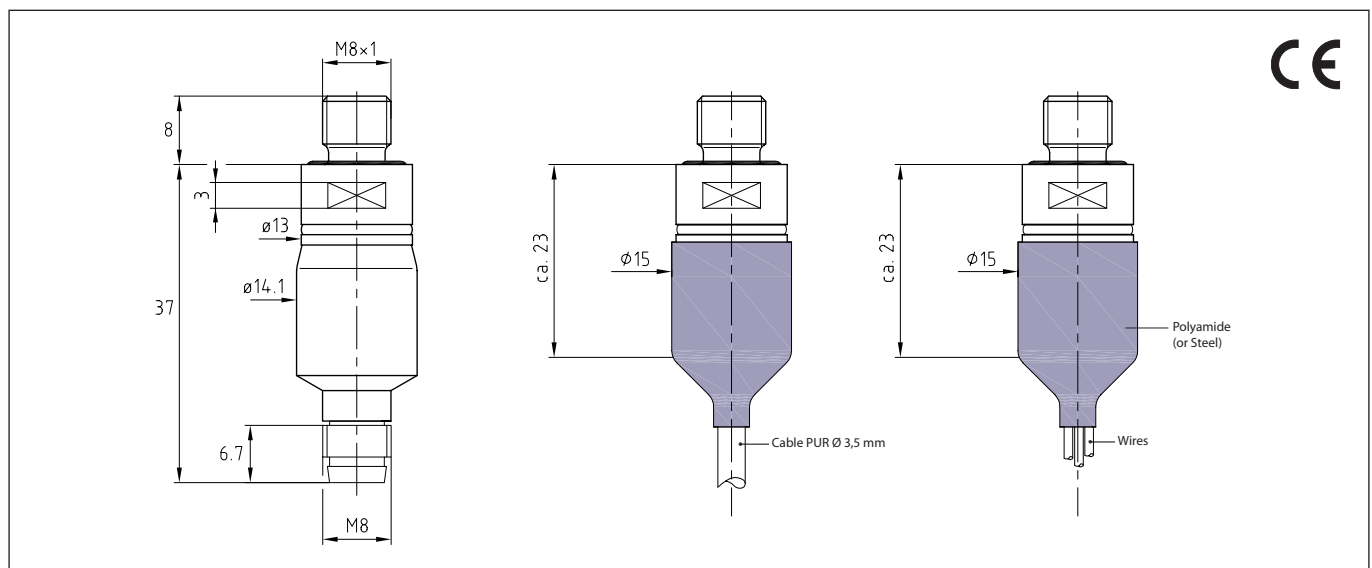

Subject to alterations

07/08

KELLER AG für Druckmesstechnik
KELLER Ges. für Druckmesstechnik mbH

St. Gallerstrasse 119
Schwarzwaldstrasse 17

CH-8404 Winterthur
D-79798 Jestetten

Tel. +41 (0)52 - 235 25 25
Tel. +49 (0)7745 - 9214 - 0

Fax +41 (0)52 - 235 25 00
Fax +49 (0)7745 - 9214 - 60



KELLER

Specifications

Pressure Ranges (all intermediate ranges possible)

PAA-21 PY / PA-21 PY	10...600 bar FS
Overpressure	2 x pressure range, max. 700 bar

PAA: Absolute. Zero at vacuum PA: Sealed Gauge. Zero at 1000 mbar abs.

Accuracy		<i>Standard</i>	<i>Premium</i>
Linearity (best fitted straight line) ¹⁾		max. $\pm 0,5$ %FS	max. $\pm 0,25$ %FS
Total Error Band ²⁾	0...50 °C	max. $\pm 1,0$ %FS	max. $\pm 0,5$ %FS
	-10...80 °C	max. $\pm 1,5$ %FS	max. $\pm 0,7$ %FS

¹⁾ including Hysteresis + Repeatability

²⁾ Linearity + Hysteresis + Repeatability + Temp. Coeff. + Zero + Span Tolerance

Storage-/Operating Temperature -20...100 °C

Stability max. $\pm 0,3$ %FS

Type 3-Wire
Signal Output **0,5...4,5 V**
Limitation Signal Output 0,1...4,9 V
Supply 8...28 VDC
Load Resistance > 5 k Ω
Limiting Frequency 2 kHz
Power Consumption max. 4 mA

Electrical Connection - Plug: M8 (3-pole)
 - Cable
 - Wires

Pressure Connection M8 x 1

Response Time (Supply ON) (0...99 %) < 5 ms
Isolation > 10 M Ω at 50 VDC
EMC EN 61000-6-2: 2005 / EN 61000-6-3: 2007 / EN 61326-2-3: 2006
Dead Volume Change < 0,1 mm³
Material in Media Contact - Stainless Steel AISI 316L (1.4404/1.4435)
 - Viton[®] Seal external (no internal seals)

Protection Class M8-Plug: IP67 (with corresponding mating plug)
 Cable: IP54

Weight \approx 18 g
Endurance > 10 million cycles, 0...100 %FS at 25 °C
Oil Filling Silicone oil

Options

Oil Filling Fluorocarbon oil (O₂-compatible)
Pressure Connection Others on request